

This Owner's Manual is provided and hosted by Appliance Factory Parts.



Urban Islands F001-MP8K Owner's Manual

[Shop genuine replacement parts for Urban Islands
F001-MP8K](#)



[Find Your Urban Islands Air Conditioner Parts - Select From 1 Models](#)

----- Manual continues below -----

ForestAir

Please read this owner's manual carefully before operating,
and keep it for reference.

Mini portable Air Conditioner

OWNER'S MANUAL



MODELS
F001-MP8K
(13-04500)

Operation Notices

SAFETY WARNING.....	1
SAFETY INSTRUCTION.....	2
INSTALLATION INSTRUCTIONS	3
INDOOR & OUTDOOR UNIT SEPARATION INSTRUCTIONS	5
WINDOW KIT INSTALLMENT METHOD	6
PARTS NAMES.....	7
BUTTONS / DISPLAY / REMOTE CONTROLLER.....	8
MAINTENANCE	12
TROUBLESHOOTING & ERROR CODES.....	13
WARRANTY	14

This appliance is not intended for use by persons (including children) with reduced physical, sensory or mental capabilities, or lack of experience and knowledge, unless they have been given supervision or instruction concerning use of the appliance by a person responsible for their safety.
Children should be supervised to ensure that they do not play with the appliance.



Do not dispose this product as unsorted municipal waste.
Collection of such waste separately for special treatment is necessary.



Safety Warning

- Please follow these instructions carefully in order to avoid damages or accidents.
 - ▶ **Warning:** Failure to follow these instructions could cause severe harm or death.
 - ▶ **Caution:** Failure to follow these instructions could lead to danger or harm.
1. Do not use the same outlet for two or more home appliances in conjunction with this unit. Do not use extension cords, as they could be a fire hazard.
 2. Do not put fingers, sticks or any other object into the air outlet. Keep away from children.
 3. Make sure the unit is shut off before cleaning it. Failure to do so could cause electrocution.
 4. Contact a recommended specialist if the unit is severely malfunctioning.
 5. Do not disassemble or remodel the unit. Failure to do so could cause malfunctions, fires or electrocution.
 6. Contact the service center after switching off the unit if you notice a strange smell or noise.
 7. Do not turn the unit on and off repeatedly while it is in operation.
 8. Make sure to use the buttons when shutting off the unit rather than unplugging it.
 9. If repairs are needed, seek the help of a service center. Do not attempt to turn on if the power cord is damaged. Failure to do so could cause fire or electrocution.
 10. Make sure that the outlet is properly grounded (115 V).
 11. Make sure the grounding does not interfere with gas pipes, water pipes or telephone wires as these could cause malfunctions, fire or electrocution.
 12. Do not staple the wires as this could severely damage them. Avoid placing the cords underneath heavy objects as well.
 13. When in use, do not separate the indoor and the outdoor units. This could cause malfunctions or electrocution.



SAFETY INSTRUCTION

Caution

1. Do not place objects on top of the unit.
2. Do not use the unit near flammable or oily substances.
3. Do not place the unit in direct sunlight, high humidity environments or highly dusty environments.
4. Ensure that the unit is kept upright at all times. Failure to do so could lead to malfunctions.
5. Do not use wax, thinners and/or organic solvents when cleaning the unit's exterior. Instead, use a dry gentle cloth.
6. Ensure that the filters are cleaned once every few weeks. To do so, remove the filter and clean them with warm water and a neutral detergent. Dirty filters can hinder on the unit's performance.
7. Always turn off the unit before attempting to clean the unit. Ensure that the fan has completely stopped.
8. Ensure that the air filter is installed correctly. Without a properly installed air filter, the unit could consume much more power, thereby shortening the lifespan of the unit.
9. Ensure that the inlet is not obstructed. This could cause malfunctions or incidents.
10. Do not install the unit in high-heat environments. This could cause fire.
11. Do not pull the power cords while the unit is functioning.
12. Use this unit for indoor cooling only.
13. While storing the unit, make sure that the indoor and outdoor units are not separated.

INSTALLATION INSTRUCTIONS

NOTE: Since cool air is denser than warm air and moves downwards, it is recommended that the indoor unit be installed high up in order to get the most out of the air conditioning unit.

Indoor unit

- Do not install on an uneven, unstable or tilted surface.
- Do not install the indoor unit in sunlight
- Do not install the unit near a flame or flammable substances.
- Do not extend power lines or use extension cables.
- Install the unit where there will be no obstruction to the air inlet and outlet.
- Avoid using in high-humidity environments.

Outdoor unit

- Do not install the unit where it runs the risk of falling. This could highly damage the unit.
- Ensure that the drainage hose is properly installed and used.
- Do not install on an uneven, unstable or tilted surface.
- For optimal performance, it is best not to install in direct sunlight.
- Do not install near fire sources or flammable substances.
- Install the unit where there will be no obstruction to the air inlet and outlet.
- Ensure that the unit is not installed on others due to noise or wind.
- Install on solid and steady structures, if need be.
- Freezing could damage the unit – do not install in area where temperature is less than 0°C (32°F)

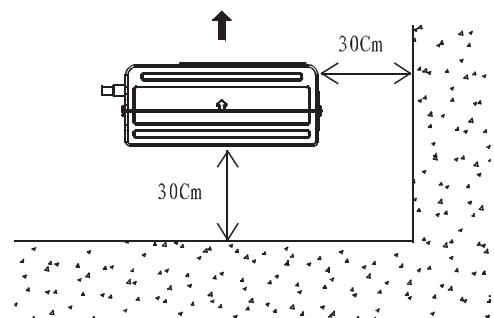
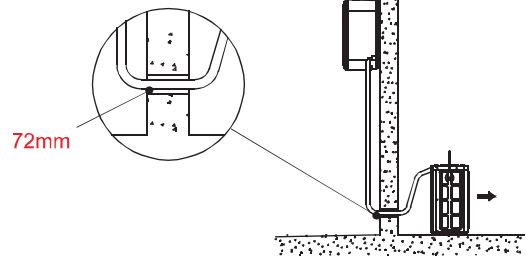
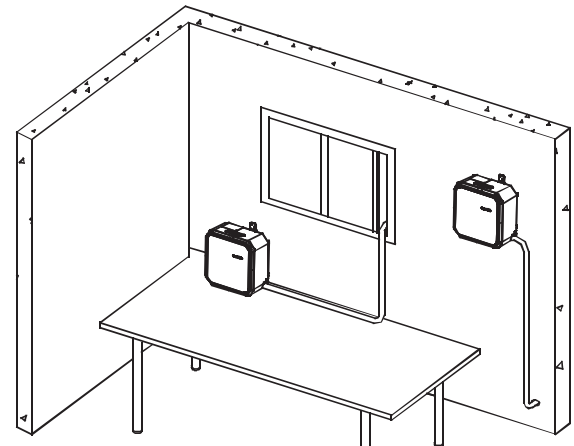

where it can cause trou-

INSTALLATION INSTRUCTIONS

Indoor unit

Installation on wall

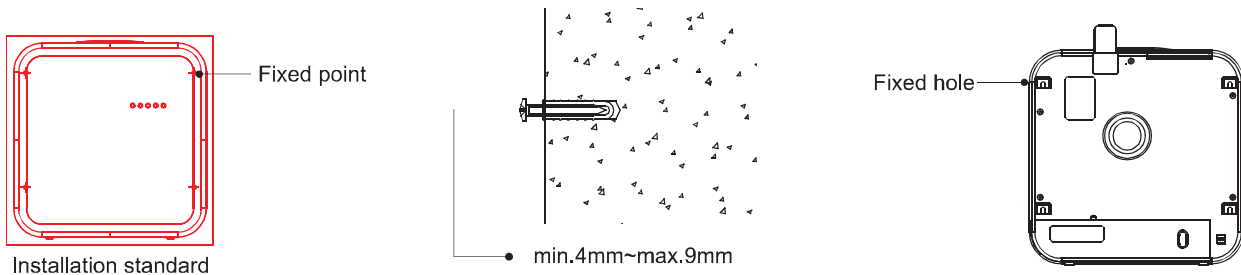

1. Mark the installation standard where you'd like to place the unit.
2. Measure each side accurately.
3. Mark the 4 corners of the unit where the fixed points will be.
4. Insert screws into the wall leaving between 4-9 mm out.
5. Install the indoor unit by hooking the fixed holes on the 4 screws, much like a picture frame.

INDOOR & OUTDOOR UNIT SEPARATION INSTRUCTIONS

Caution

- Never store the indoor and outdoor unit disconnected.
- Never separate them while the unit is functioning.
- Never operate the unit unless both parts are properly connected.

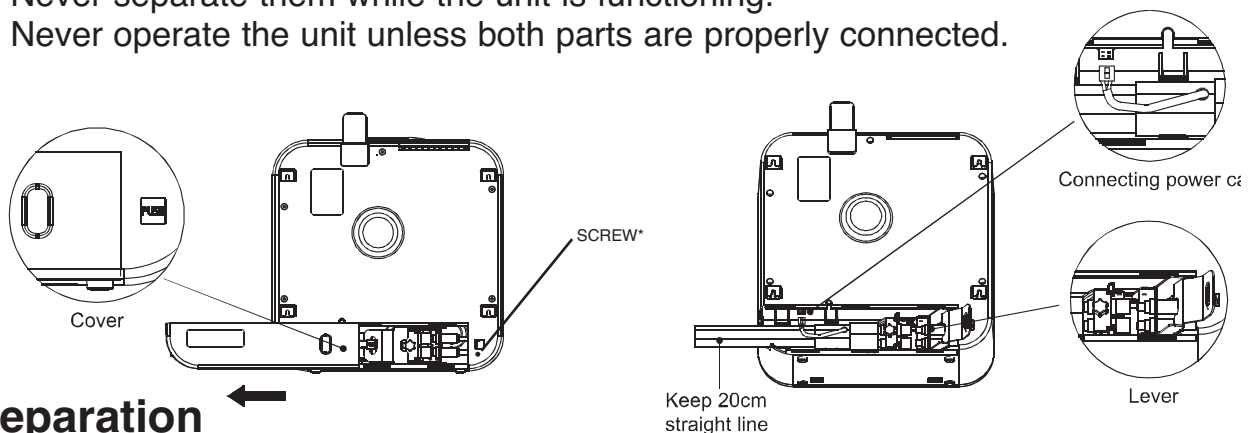

Separation

1. Let the unit rest 10 minutes after use. *Remove screw in corner of the unit. Push the cover in the direction of the arrow to open, as shown above. Use grooves to help slide the cover off if needed.
2. Slowly open the lever while keeping the quick connector in a straight line. Do not bend it. A bit of refrigerant may escape. Disconnect the electric cable.

INDOOR & OUTDOOR UNIT SEPARATION INSTRUCTIONS

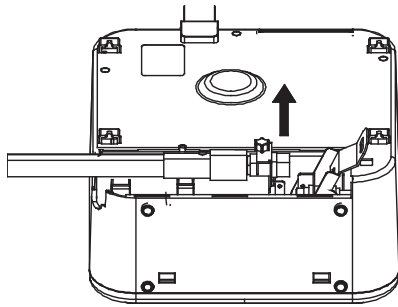

Separation

3. Gently lift the quick connector to separate. Do not keep both parts separate for extended periods of time. Whenever possible, keep the indoor and outdoor units connected to each other when moving the units.

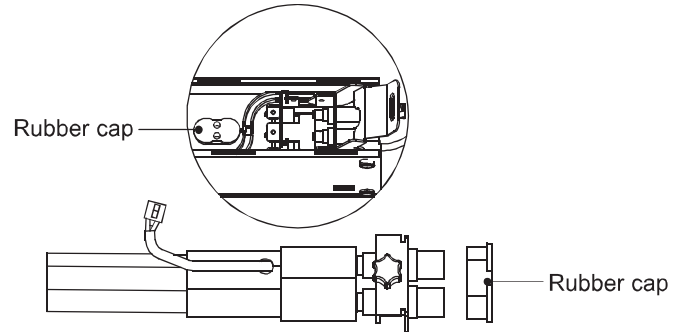

4. Insert the rubber cap in the connector to avoid refrigerant leaks. This should be used temporarily, as both units should be connected whenever possible.

Connection

1. Open the quick connector lever, as shown below.
2. After removing the rubber cap, fit one end of the connecting hose into the linear guide of the quick connector.
3. Swiftly close the lever. Ensure that the connection is not tangled. Keep as straight as possible. Connect the electric cable.
4. Close the cover.

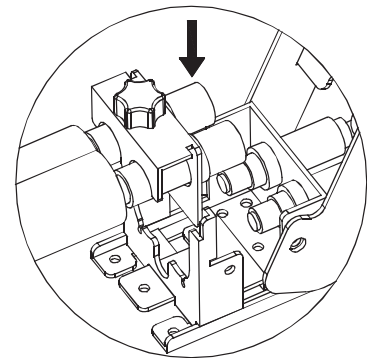
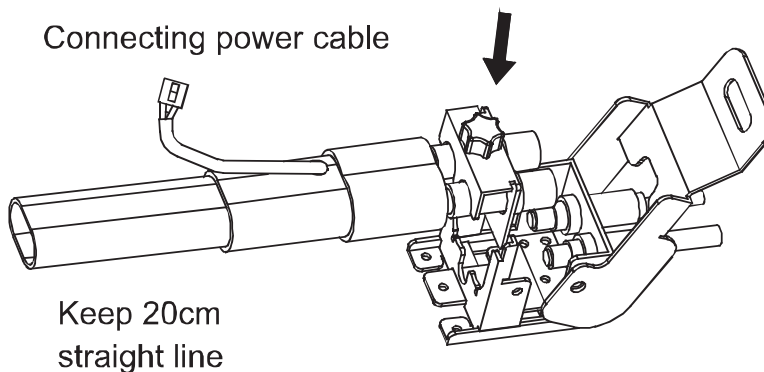

WINDOWS KIT INSTALLMENT METHOD

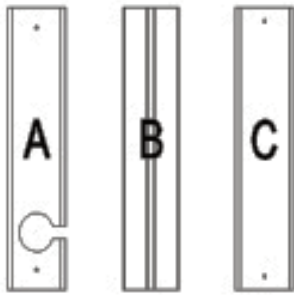

Window Kit Extension Panels



Rubber Connector



Screw Kit

1. Insert the T-bolt into extension panel A (and panel C if necessary, depends on the height of the window); then slide the T-bolt into the groove of panel B.
2. Assemble the screw kit as in picture 3, then add the washer and tighten the wing nut base. The user can adjust the height according to the window size.

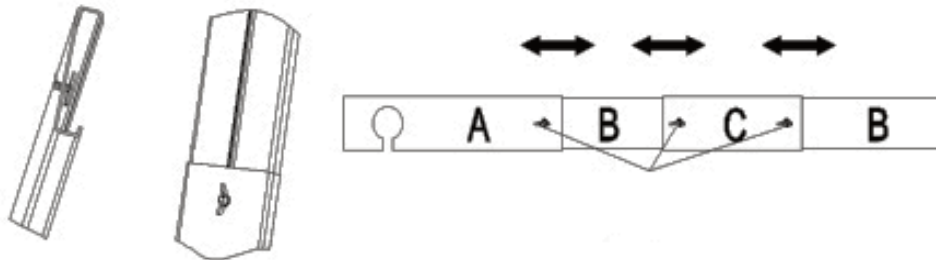

3. Insert the cable connecting the two units together into the opening on the rubber connector.
4. Thightly anchor the rubber connector into the window kit panel A.
5. Adjust the rubber connector, making sure the hook is anchored correctly.

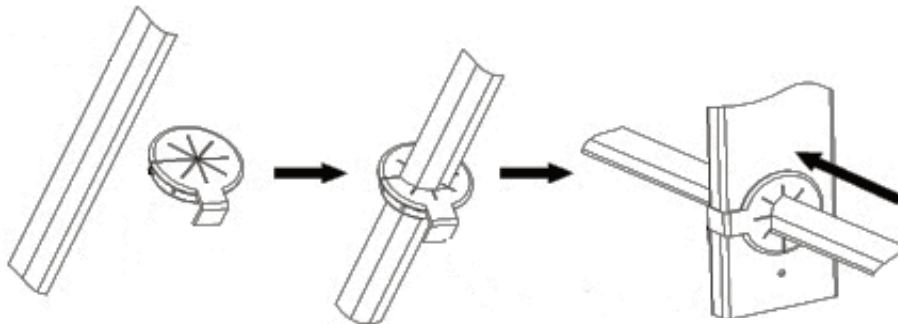

6. Once the window kit assembly is finished, tighten the screws and make sure the window is sealed tightly.

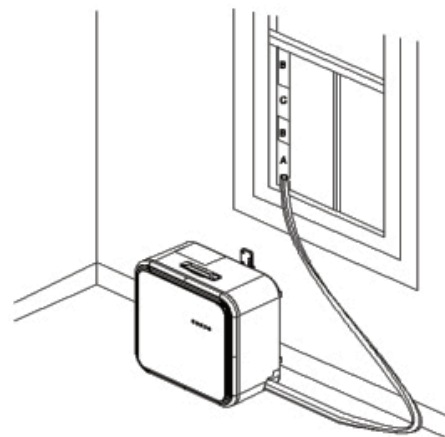

PART NAMES

INDOOR UNIT

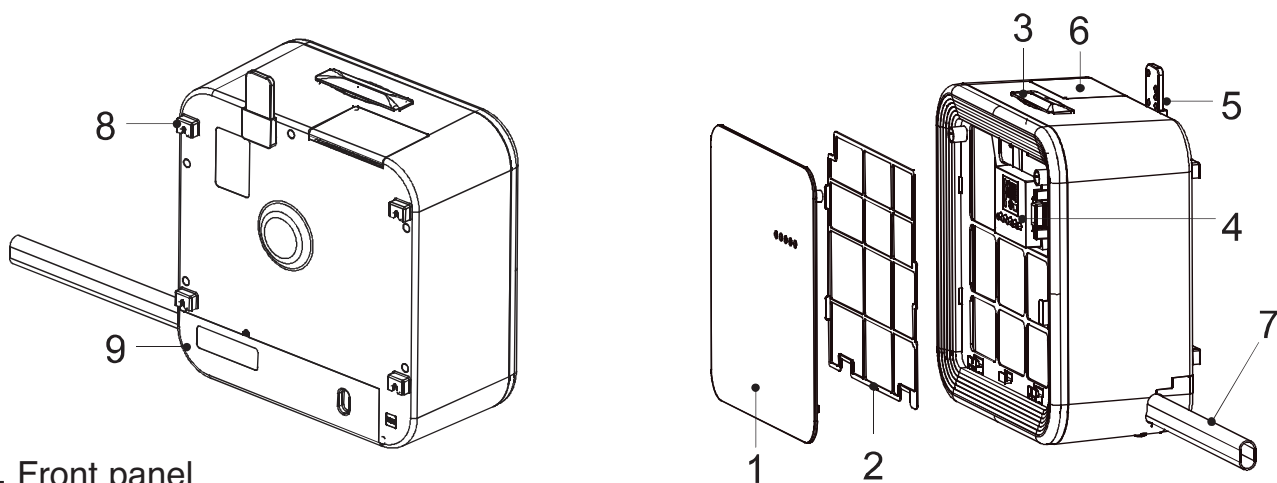

1. Front panel
2. Filter
3. Handle
4. Operation and display
5. Fixed loops: remote control holder
6. Air outlet: emitting cooling air
7. Connecting cable: connecting indoor & outdoor
8. Fixed loops: to fix indoor unit onto wall
9. Coupler cover: for use in installation and separation

OUTDOOR UNIT

1. Handle
2. Air outlet: emitting hot wind
3. Connecting cable: free flexibility
4. Condensation outlet: to drain water
5. Coupler

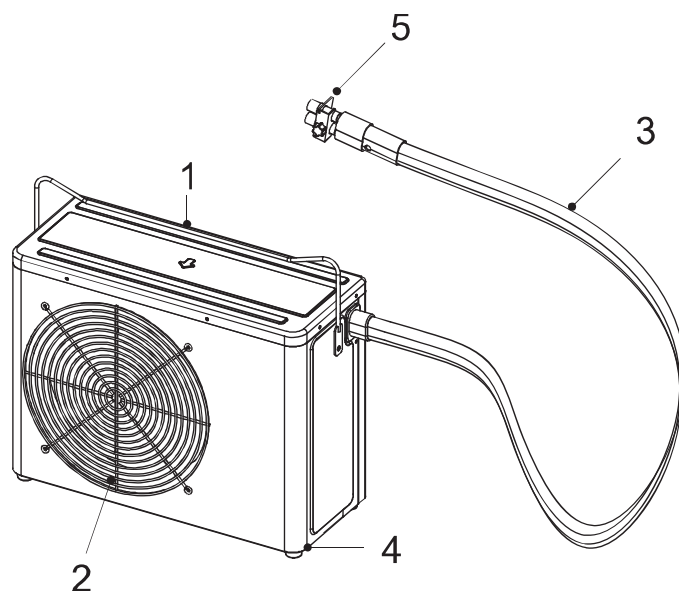

BUTTONS / DISPLAY / REMOTE CONTROLLER

Timer and temperature control can only be controlled by the remote.

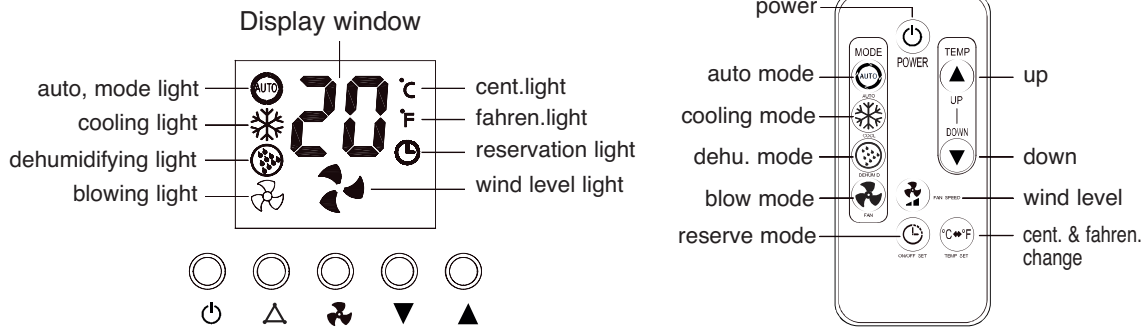

- Power button: turn unit on and off
- Selection button: select the desired mode (Cooling, Dehumidifying, Fan, Sleep)
- Up/Down button: set time and temperature.
- Timer button: turn on timer.
- Fan Speed button: set fan speed
- Temperature Change button: Set temperature.
- Fan Speed Indicator: Displays selected fan speed.
- Timer Indicator: Timer is activated when the light is on.
- Automatic Operation Indicator: Automatic operation is activated when the light is on.
- Cooling Mode Indicator: Cooling mode activated when the light is on.
- Dehumidifying Mode Indicator: Dehumidifying mode is activated when the light is on.
- Fan Mode Indicator: Fan mode is activated when the light is on.
- Centigrade & Fahrenheit Indicator: Indicates which unit is currently set.

Changing battery of remote controller and instruction

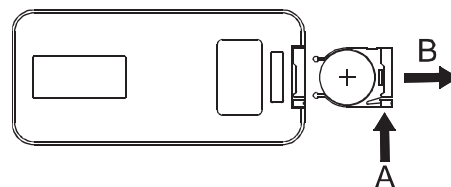
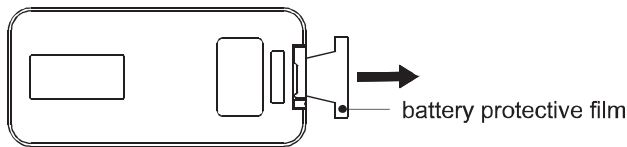

- Remove the battery's protective film before initial use.

- Press on the lock (A arrow) and pull off the cover (B arrow). Change the battery (CR 2035 3V)

CAUTION

- Do not press two buttons simultaneously.
- Do not use force on the unit as this will lead to malfunction.
- Avoid using in excessive heat (fire) or humidity (water).
- Remove the battery in the remote control if it is not used regularly to avoid battery leaks.
- For best results, use the remote control within 7m of the unit while pointing directly at it.

Automatic cooling mode

- Unit will switch automatically between Cooling and Fan mode to adequately maintain a desired temperature.

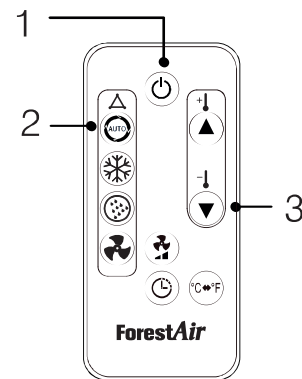
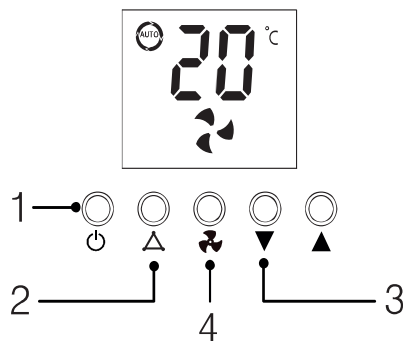

1. Press power button
 2. Press the selection button until the indicator is set on Auto.
 3. Press the up/down button to set temperature.
- A.** If the temperature set is higher than the ambient temperature, the unit will automatically function in Fan Mode.

Cooling mode

- Unit will function in Cooling mode, while allowing you to set the fan speed and temperature.

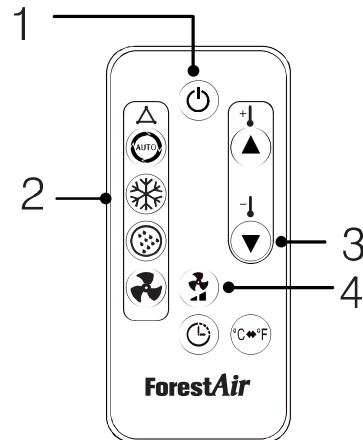
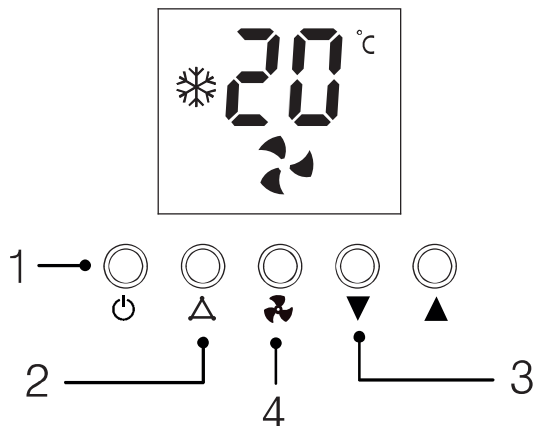

1. Press power button
2. Press the selection button until the indicator is set on Cooling Mode.
 - A.** If on the remote, press the Cooling button.
3. Press the up/down button to set the temperature.
4. Press Fan Speed button to set a desired fan speed.

DEHUMIDIFYING MODE

- Unit will remove moisture from the air.

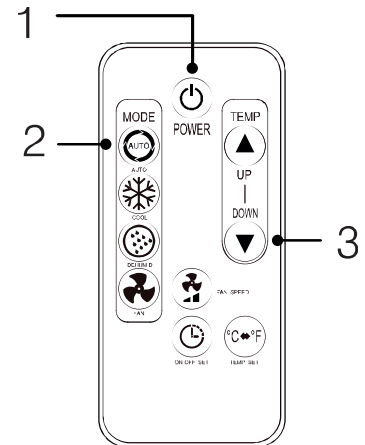
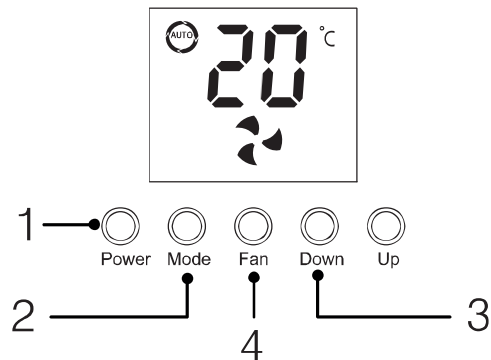

1. Press power button
2. Press the selection button until the indicator is set on Dehum Mode.
 - A. If on the remote, press the Dehum button.
3. When in Auto mode on low Fan Speed, the Dehum mode will automatically start.

FAN MODE

- Allows the indoor unit to function without activating the outdoor unit.

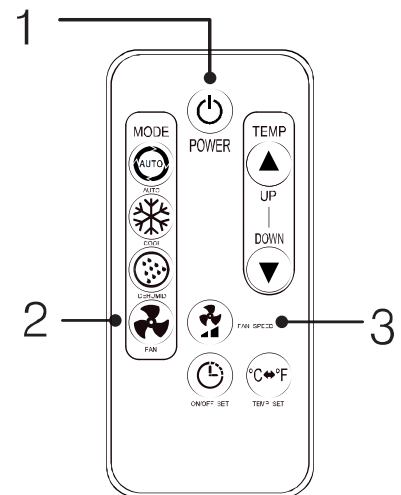
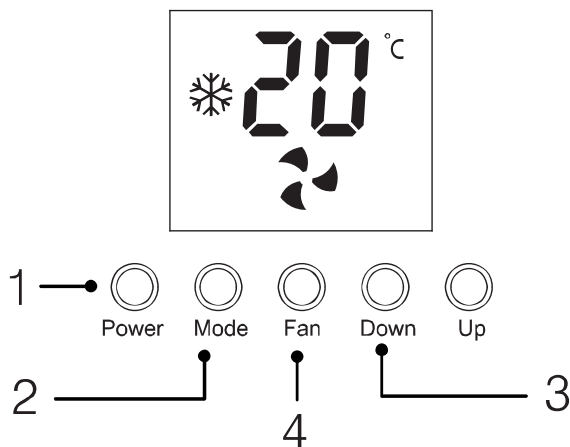

1. Press power button
2. Press the selection button until the indicator is set on Fan Mode.
 - A. If on the remote, press the Fan button.
3. Fan speed is adjustable by pressing the Fan button.

TIMER

- **Setting the Power-On Time**

Can only be set with the Remote Control



In setting reserve operation
(Air conditioner switches off after 2 hours.)

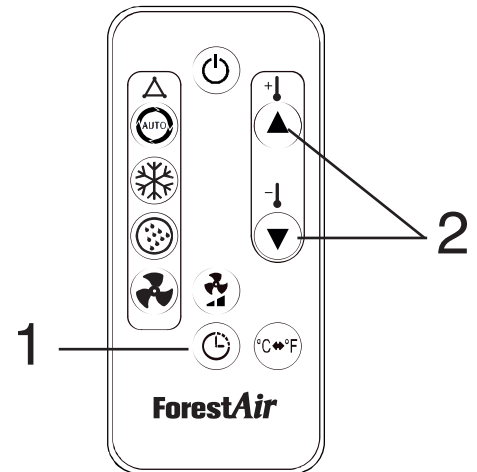

Ensure that the unit is turned on, but not functioning (stand-by mode)

1. Press the Timer button. The Timer indicator should turn on.
2. Set the Power-On time by using the Up/Down buttons.
 - A. Time will move in 1-hour increments. Can be set up to 24 hours.
 - To undo the Timer, simply switch the unit off.

- **Setting the Power-Off Time**

Can only be set with the Remote Control.

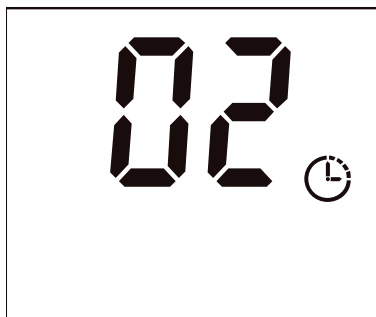

*Ensure that the unit is turned on and
functioning (any mode)

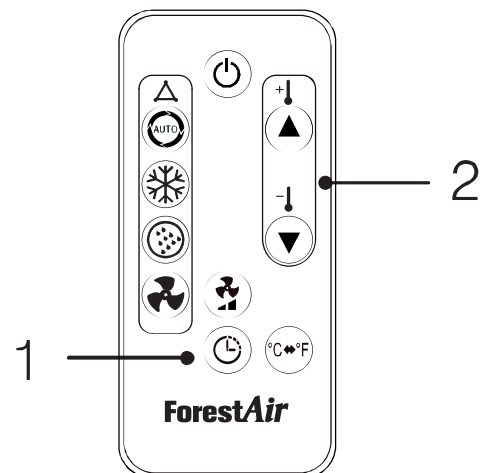

1. Press the Timer button. The Timer indicator should turn on.
2. Set the Power-Off time by using the Up/Down buttons.
 - Time will move in 1-hour increments. Can be set up to 24 hours.
 - ※ To undo the Timer, simply switch the unit off.

MAINTENANCE

• Cleaning the Air Filter

Ensure that the unit is unplugged in order to avoid electric shocks.

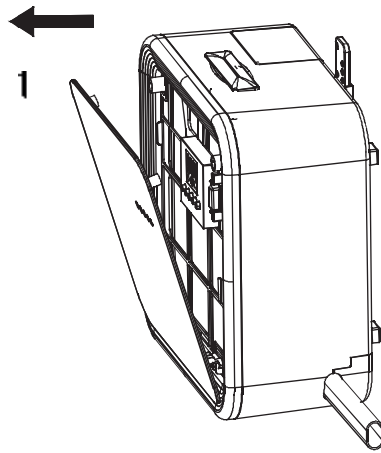

1. Pull off the front panel in arrow direction.

2. Pull out the filter in arrow direction. Gently clean the filter with warm soapy water. Let air dry in a cool place.

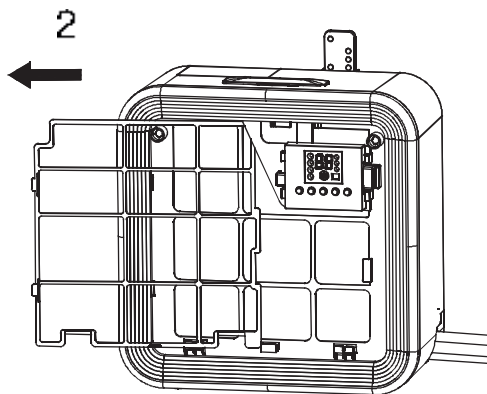

Caution

- Clean the air filter once every few weeks.
- Regular cleaning will allow for the best performance.
- Do not use hot water, as the filters may deform or bend.
- Using too much pressure to clean the air filters could permanently damage them. Clean them gently.
- Do not use the unit without the air filter.

Cleaning the Unit's Exterior

1. Clean with a soft damp cloth and let dry.
2. Do not use thinners or acids on the surface, as these can cause damage to the product's finish.
3. Ensure that no water enters the unit, as this can cause damage to the unit.

General Maintenance

1. Unplug the unit when it is not in use.
2. Drain the water out after use. Slightly tilt the unit backwards and let the water evacuate through the drainage hole.
3. To dry the inside, set on Fan Mode for 2 hours.
4. Reassemble the unit after the filters have dried.
5. Keep indoor and outdoor units connected.
6. Store the unit in a box in a cool dry place. Both units should be connected in storage.

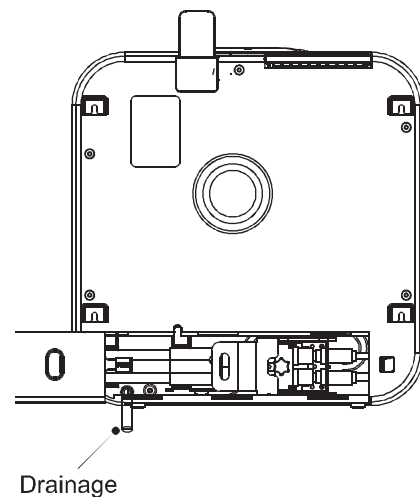

Troubleshooting

Problem	Check List	Solution
Unit does not operate	<ol style="list-style-type: none"> 1. Power is switched on 2. The electricity is on 3. Inlet or discharge port is unobstructed 4. Voltage is correct 5. Inside fuse is in good not damaged 	<ol style="list-style-type: none"> 1. Switch on main power. 2. Check another electrical appliance 3. Check if inlet or discharged port of indoor unit is blocked. 4. Check input voltage. 5. Call a Service Center
Unit does not produce cold air	<ol style="list-style-type: none"> 1. Unit was off and restarted in Cooling mode. 2. Cooling mode was just switched to from another mode. 	<ol style="list-style-type: none"> 1. When the unit starts to run in Cooling mode, it takes 3 minutes to the compressor to start operating, cooling the air. During the first 3 minutes, only the fan will be running.
Unit does not cool	<ol style="list-style-type: none"> 1. Temperature is set correctly 2. Filter is clean and unobstructed 3. Unit's cooling capacity is enough for the designated space 	<ol style="list-style-type: none"> 1. Set desired temperature 2. Clean filter more than once a week. 3. Check the cooling capacity.
Noise & Vibration	<ol style="list-style-type: none"> 1. Unit is on an even and straight surface. 2. Filters are clean and unobstructed 	<ol style="list-style-type: none"> 1. Move to flat surface. 2. Clean filter

Error Codes

Error code	Meaning	Cause & Solution
E0	Drain	Drain pump or water sensor. Call Service Technician
E1	Indoor temp. sensor	Indoor temperature sensor. Call Service Technician
E2	EVA sensor	EVA sensor. Call Service Technician
E6	Over heating	Clean filter. If failure persists. Call Service Technician
E7	Over cooling	Check connection cable between both units. Call Service Technician

- Call to manufacturer or After service center for After service

WARRANTY**LIMITED WARRANTY**

This portable air conditioner is covered by a warranty against defects in materials and workmanship, if used for the applications specified in this owner's manual, for a period of (1) year from the date of original purchase in Canada.

During the warranty period, if the portable air conditioner fails under normal use, ForestAir will, at its option, either repair the unit or replace it, free of charge, within a reasonable period of time after the portable air conditioner is returned.

As a condition to any warranty service obligation, the customer must present this warranty certificate along with the proof of purchase.

THIS WARRANTY DOES NOT COVER :

1. Damage, accidental or otherwise, to the portable air conditioner that not caused by materials or workmanship defect.
2. Damage caused by misuse, tampering or failure to follow the operating and maintenance instructions provided in this owner's manual.
3. Damage to the finish of the unit enclosure or to other outer features caused by wear.
4. The filters.
5. Damage caused by repairs or modifications to the portable air conditioner made by any person not duly authorized by ForestAir.
6. Insurance and freight costs for the warranty service.

ALL IMPLIED WARRANTIES, INCLUDING ANY IMPLIED WARRANTY OF MERCHANTABILITY, ARE LIMITED TO A ONE YEAR (1) PERIOD COVERED BY THIS EXPRESS LIMITED WARRANTY. FORESTAIR DISCLAIMS ANY LIABILITY FOR CONSEQUENTIAL OR INCIDENTAL DAMAGES AND, IN NO EVENT, SHALL FORESTAIR LIABILITY EXCEED THE RETAIL VALUE OF THE PORTABLE AIR CONDITIONER FOR BREACH OF ANY WRITTEN OR IMPLIED WARRANTY WITH RESPECT TO THIS PORTABLE AIR CONDITIONER.

Keep this owner's manual along with your proof of purchase in a safe place for future reference. You must provide proof of purchase for warranty service.

Enter the following information on your portable air conditioner; it will help you upon getting assistance or service if you ever need it. You will have to provide the model and serial numbers of the portable air conditioner – these data are detailed on the rating plate of the unit.

Dealer name : _____

Address : _____

Model number: _____

Serial number : _____

Date of purchase : _____

