

AUTHENTIC

**SMOKE
HOLLOW®**

Owner's Manual

Digital Electric Smoker

For Models:

**3616DEW / 3616DEWS
CAB3617**

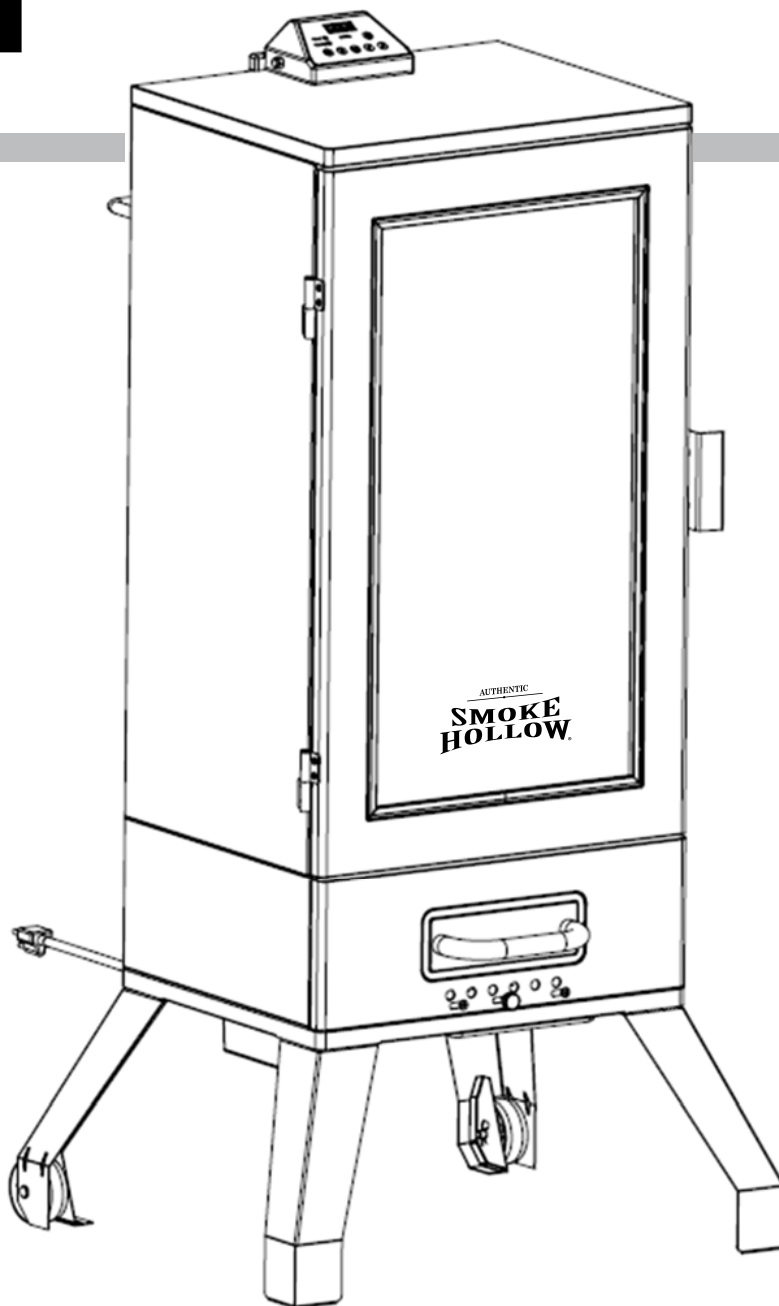

**THIS IS YOUR ASSEMBLY, CARE & USE MANUAL
WITH IMPORTANT WARNING & SAFETY INFORMATION.
PLEASE SAVE THESE INSTRUCTIONS.**

Approximate assembly time: 20 minutes
Tools needed for assembly: Phillips head screwdriver

FOR OUTDOOR USE ONLY

WARNING

THIS MANUAL CONTAINS IMPORTANT INFORMATION NECESSARY FOR THE PROPER AND SAFE USE OF THIS UNIT. READ AND FOLLOW ALL WARNINGS AND INSTRUCTIONS BEFORE USING SMOKER AND DURING USE.

**FAILURE TO FOLLOW THESE WARNINGS AND INSTRUCTIONS PROPERLY
COULD RESULT IN PERSONAL INJURY OR DEATH.**

CARBON MONOXIDE HAZARD

BURNING WOOD CHIPS GIVES OFF CARBON MONOXIDE, WHICH HAS NO ODOR AND CAN CAUSE DEATH. DO NOT BURN WOOD CHIPS INSIDE HOMES, VEHICLES, TENTS, GARAGES OR ANY ENCLOSED AREAS. USE ONLY OUTDOORS WHERE IT IS WELL VENTILATED.

GENERAL WARNINGS

READ ALL INSTRUCTIONS

- Do not leave smoker unattended.
- Do not cover cooking racks with metal foil. This will trap heat and cause severe damage to the electric smoker.
- Drip tray is only for the bottom of electric smoker. Do not put drip tray on cooking rack as this may damage the electric smoker.
- The wood chip tray is HOT when electric smoker is in use. Use caution when handling or adding wood.
- To disconnect, turn control panel "OFF" then remove plug from outlet.
- Unplug from outlet when not in use and before cleaning. Allow unit to cool completely before adding/removing grates, wood chip tray or water pan.
- Dispose of cold ashes by placing them in aluminum foil, soaking with water and discarding in a non-combustible container.
- Do not store the electric smoker with HOT ashes inside unit. Store only when all surfaces are cold.
- Accessory attachments or parts not supplied by Outdoor Leisure Products, Inc. are not recommended and may cause injury.
- Never use the electric smoker for anything other than its intended purpose. This unit is not for commercial use.
- Always use the electric smoker in accordance with all applicable local, state and federal fire codes.
- Longer, detachable power-supply cords or extension cords are available and may be used if care is exercised in their use, based on the following requirements.
- If a longer, detachable power-supply cord or extension cord is used, the marked electrical rating of the cord set or extension cord should be at least as great as the electrical rating of the appliance.
- The extension cord must be a grounding -type 3-wire cord.
- Outdoor extension cords must be used with outdoor use products and are marked with suffix "W" and with the statement "Suitable for Use with Outdoor Appliances."
- CAUTION- To ensure continued protection against risk of electric shock, connect to properly grounded outlets only.
- CAUTION - To reduce the risk of electric shock, keep extension cord connection dry and off the ground.
- Do not clean this product with a water sprayer or the like.
- Do not use wood pellets or wood chunks.
- Store products indoors when not in use - out of reach of children.

**CONTINUED ON
NEXT PAGE...**

GENERAL WARNINGS

When using electrical appliances, basic safety precautions should always be followed including the following:

- For outdoor use only. Do not operate in an enclosed areas (example, porch or garage).
- Unit **MUST** be on the ground. Do not place unit on tables or counters. Do **NOT** move unit across uneven surfaces.
- Do not lift unit by rear handle.
- Do not plug in the electric smoker until fully assembled and ready for use.
- Use only an approved grounded electrical outlet.
- Do not use during an electrical storm.
- Do not expose the electric smoker to rain or water at anytime.
- **CAUTION-** To ensure continued protection against risk of electric shock, connect to properly grounded outlets only.
- To protect against electrical shock do not immerse cord, plug or control panel in water or other liquid.
- Do not operate any appliance with a damaged cord or plug, or after appliance malfunctions or has been damaged in any manner. Contact OLPI Customer Service for assistance at 1-866-475-5180.
- Keep a fire extinguisher accessible at all times while operating the electric smoker.
- Do not let cord touch hot surfaces.
- Do not place on or near a hot gas or electric burner, or in a heated oven.
- Keep children and pets away from electric smoker at all times. Do not allow children to use electric smoker. Close supervision is necessary should children or pets be in area where the electric smoker is being used.
- Fuel, such as charcoal briquettes or heat pellets, are not to be used in the electric smoker.
- Never use the electric smoker as a heater (READ CARBON MONOXIDE HAZARD ON PAGE 2).
- Use the electric smoker only on a level, stable surface to prevent tipping.
- The electric smoker is **HOT** while in use and will remain **HOT** for a period of time afterwards. Use caution.
- Do not touch **HOT** surfaces. Use handles or knobs.
- Do not allow anyone to conduct activities around the electric smoker during or following its use until the unit has cooled.
- The use of alcohol, prescription or non-prescription drugs may impair the user's ability to properly assemble or safely operate the electric smoker.
- Avoid bumping or impacting the electric smoker.
- Never move the electric smoker when in use. Allow the smoker to cool completely before moving or storing.
- Be careful when removing food from the electric smoker. All surfaces are **HOT** and may cause burns. Use protective gloves or long, sturdy cooking tools.
- Avoid using the smoker on wooden or flammable surfaces.
- Store products indoors when not in use - out of reach of children.

WARNING

CALIFORNIA PROPOSITION 65

This product contains, or the use of this product releases, chemicals known to the State of California to cause cancer and birth defects or other reproductive harm. For more information go to www.P65Warnings.ca.gov.

SAVE THESE INSTRUCTIONS



Congratulations

on your purchase of your new
Smoke Hollow® Digital Electric Smoker.

With proper set-up, operation and maintenance, this appliance will provide you with years of delicious food and cooking enjoyment.

IMPORTANT





When you un-pack your smoker, remove all parts and packaging material from the box and inside the smoker. Make sure you have all the items on the parts list. Carefully check the unit and make sure there is no damage.

**IF YOU HAVE ANY PROBLEMS WITH THIS PRODUCT OR THERE ARE MISSING OR DAMAGED PARTS , PLEASE CALL CUSTOMER SERVICE TOLL FREE
1-866-475-5180 (Monday–Friday, 8:30 am–4:30 pm, CST).**

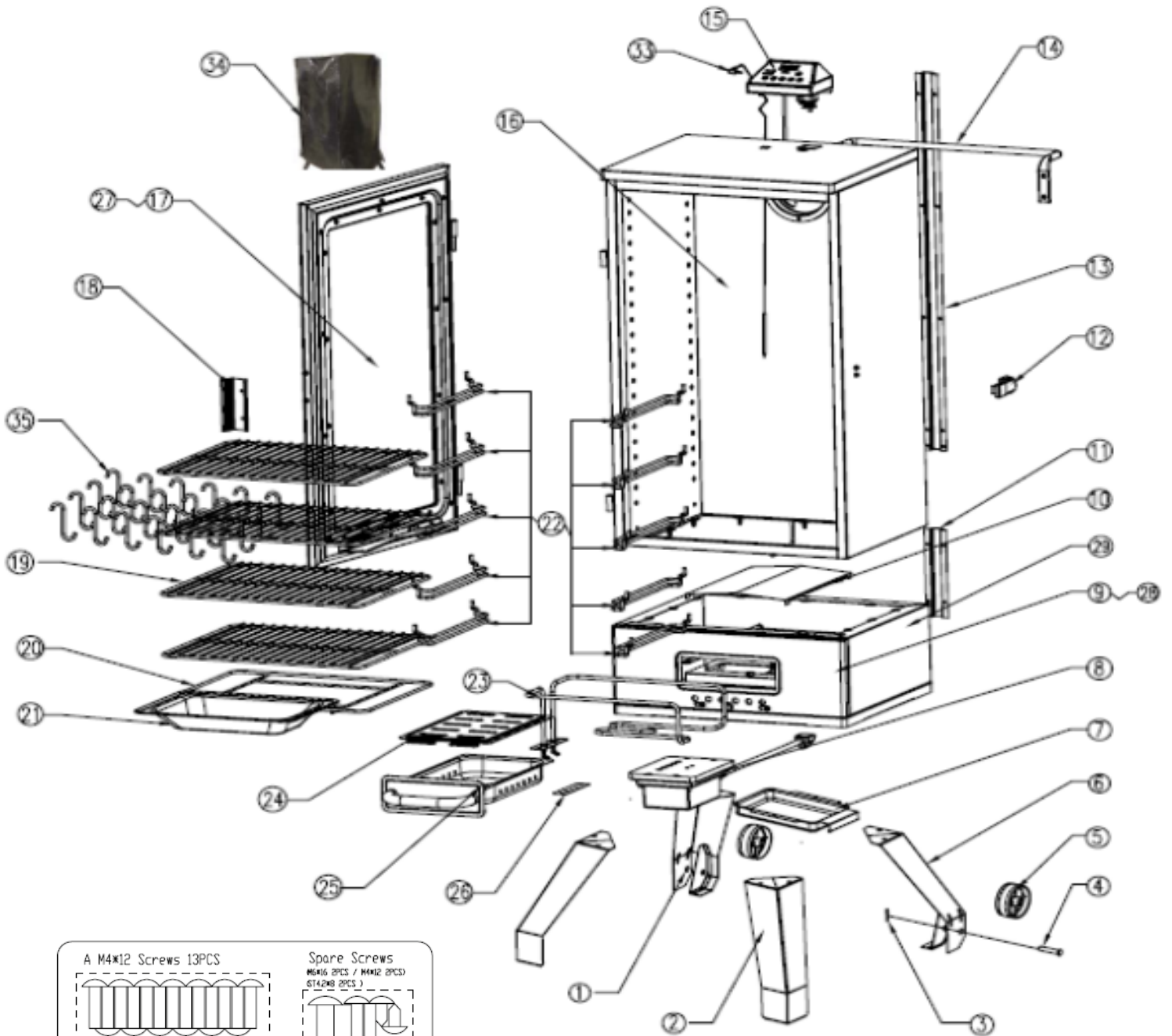
**NOTE : DO NOT RETURN UNIT TO THE STORE BEFORE CALLING THE TOLL FREE NUMBER.
Do not dispose of your cartons until you are completely satisfied with your new Smoke Hollow smoker.**

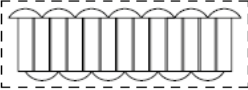
Parts and Tool List



<p>A M4*12 Screws 13PCS</p> 	<p>Spare Screws M6*16 2PCS / M4*12 2PCS ST4*8 2PCS</p> 
<p>B ST4.2*8 Screws 18PCS</p> 	
<p>C M6*16 Screws 12PCS</p> 	
<p>D Vent Knob 1PC</p> 	

YX100-0102-79

Tools needed for assembly:
Phillips head screwdriver

Parts and Tool List

Note: For assistance, including missing or damaged parts, call
toll free 1- 866-475-5180 from 8:30 am - 4:30 pm Central Time, Monday - Friday

Part #			Part Name	Quantity
3616DEW	3616DEWS	CAB3617		
1	1	1	Rear-Left Leg	1
2	2	2	Front Leg	2
3	3	3	R-Clip	2
4	4	4	Axle Pin	2
5	5	5	Wheel	2
6	6	6	Rear-Right Leg	1
7	7	7	Grease Tray	1
8	8	8	Power Box Assembly	1
9	28	28	Lower Cabinet Front Panel	1
10	10	10	Heat Tent	1
11	11	11	Cable Cover - Short	1
12	12	12	Door Latch Assembly	1
13	13	13	Cable Cover - Long	1
14	14	14	Rear Handle	1
15	15	15	Control Panel Assembly	1
16	16	16	Upper Cabinet	1
17	27	27	Door Assembly	1
18	18	18	Door Handle	1
19	19	19	Cooking Grid	4
20	20	20	Water Pan Support	1
21	21	21	Water Pan	1
22	22	22	Grid Support	10
23	23	23	Heating Element	1
24	24	24	Wood Chip Tray Lid	1
25	25	25	Wood Chip Tray Assembly	1
26	26	26	Heating Element Gasket	1
29	29	29	Lower Cabinet	1
30	30	30	Vent Knob	1
31	31	31	Hardware Pack	1
32	32	32	Instruction Manual	1
N/A	N/A	33	Meat Probe	1
N/A	N/A	34	Smoker Cover	1
N/A	N/A	35	S-Hook	24

Smoker Assembly

Step 1

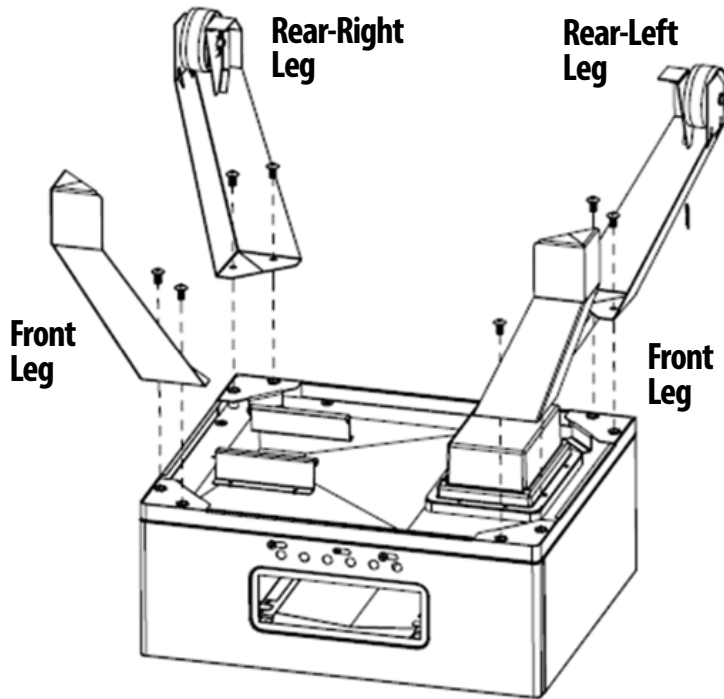

Locate:

- Lower Cabinet Assembly
- (2) Front Legs
- Rear-Left Leg
- Rear-Right Leg
- (8) M6 x 16 Screws

Tools Needed:

Phillips Screwdriver

Procedure:

Use (8) M6x16mm Screws to assemble the Legs to the Lower Cabinet Assembly as shown.

Step 2

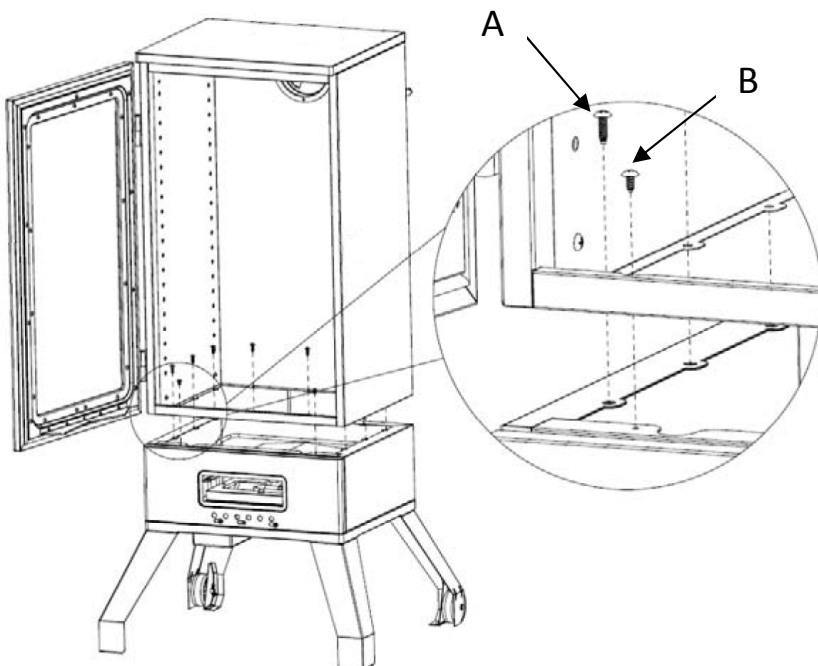

Locate:

- Lower Cabinet Assembly
- Upper Cabinet Assembly
- (9) M4 x 12 Screws
- (2) ST4.2 x 8 Self-tapping Screws

Tools Needed:

Phillips Screwdriver

Procedure:

Use (9) M4x12mm Screws and (2) ST4.2x8mm Self-Tapping Screws to assemble the Upper Cabinet Assembly into the Lower Cabinet Assembly as shown.

Note: The (2) ST4.2x8 Self-Tapping Screws are noted as "B" in illustration and attach along the front opening.

Smoker Assembly

Step 3

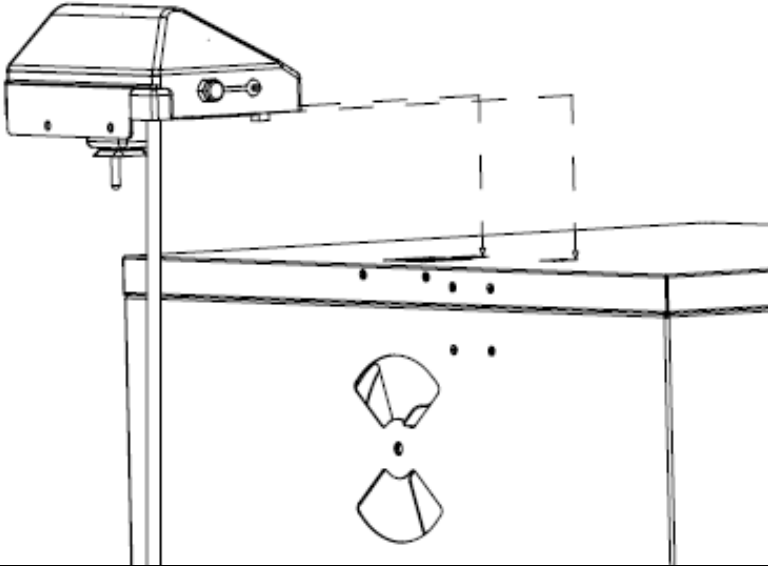

Locate:

- Upper Cabinet
- Control Panel Assembly
- Cable Cover - Long
- (12) ST4.2 x 8 Self Tapping Screws

Tools Needed:

Phillips Screwdriver

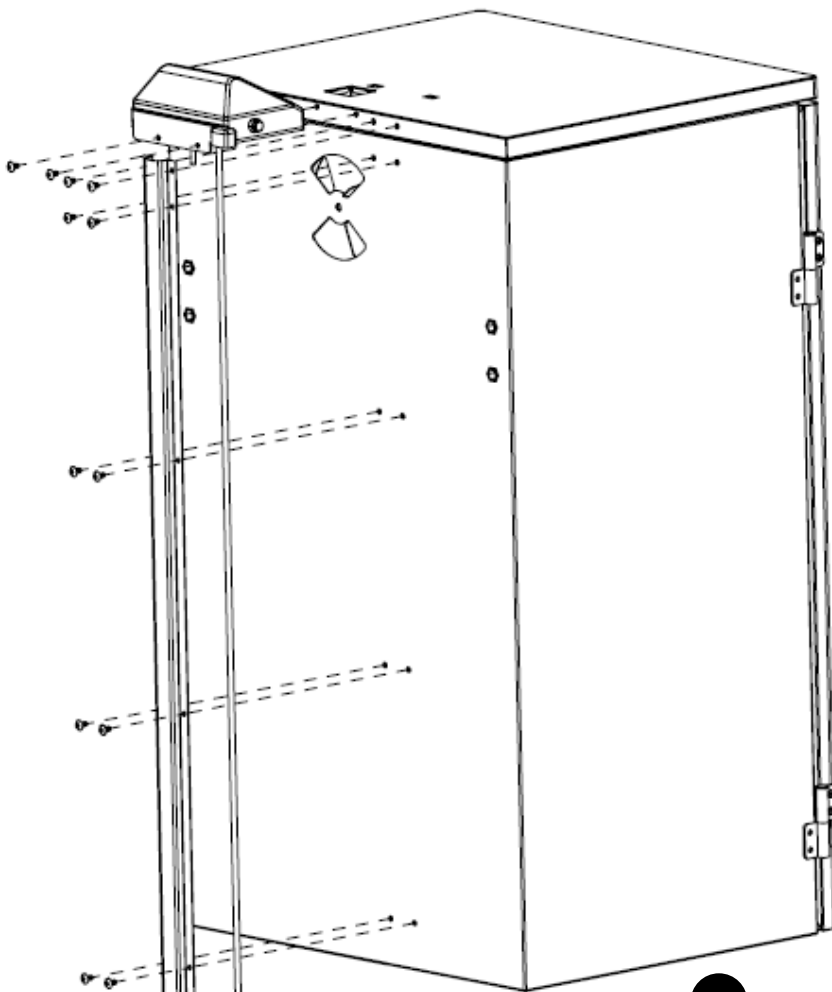

Procedure:

Place two hooks of Control Panel onto the Cabinet square holes and push back into place as shown. Use (2) ST4.2x8mm Self-tapping Screws to assemble the Control Panel Assy into the Upper Cabinet as shown. Use (10) ST4.2x8mm Self-tapping Screws to assemble the Cable Cover into the Upper Cabinet as shown.

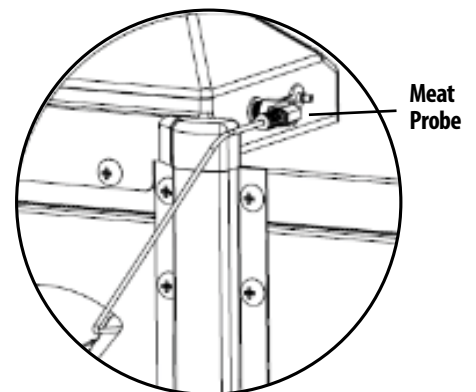

For Model CAB3617 only:

Plug in the supplied Meat Probe into the Control Panel and feed the Probe through the back vent as shown here.

Smoker Assembly

Step 4

Locate:

- Lower Cabinet
- Cable Cover - Short
- (4) ST4.2 x 8 Self-Tapping Screws

Tools Needed:

Phillips Screwdriver

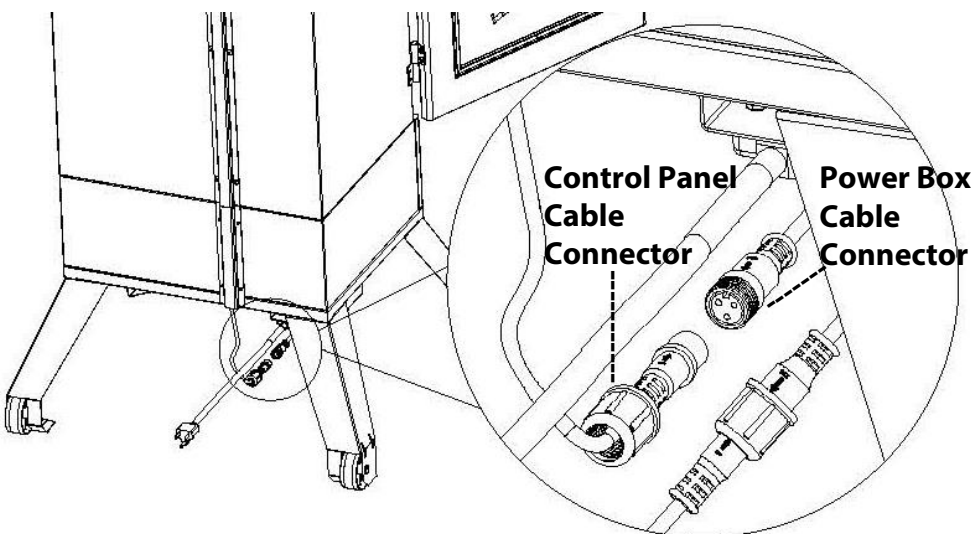
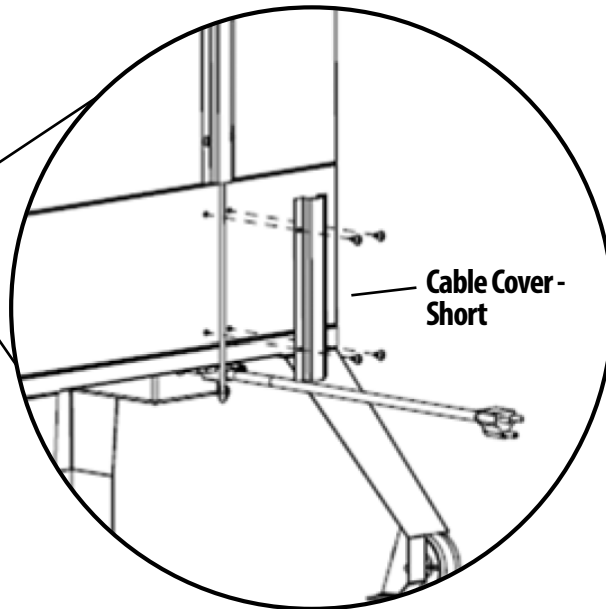
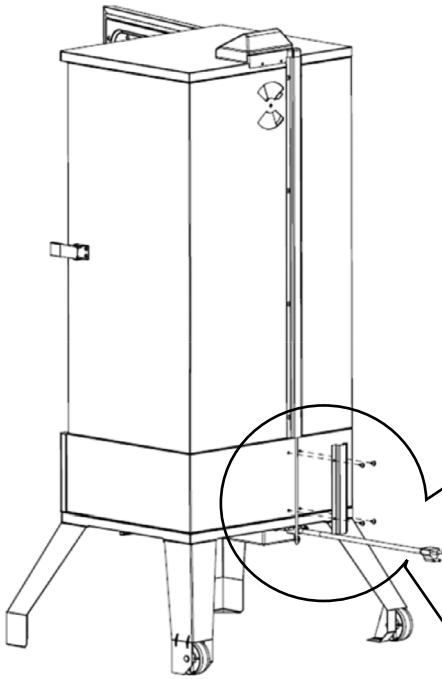

Procedure:

Use (4) ST4.2 x 8 Self-Tapping Screws to assemble the Cable Cover-Short into the Lower Cabinet as shown.

Connect Control Panel Cable and Power Box Cable together by aligning the two arrows on top of the connectors and pushing them together. Once connection is made, firmly tighten connector nut as shown.

Smoker Assembly

Step 5

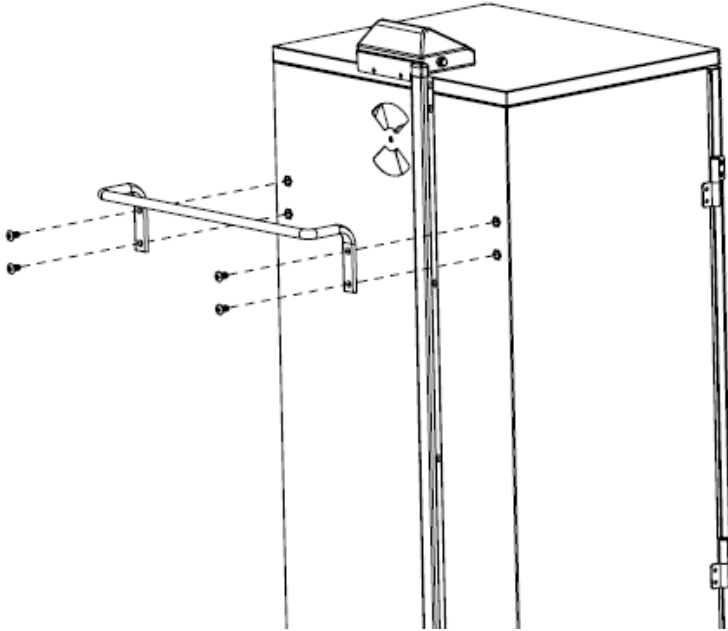

Locate:

- Rear Handle
- (4) M6 x 16 Screws

Tools Needed:

Phillips Screwdriver

Procedure:

Use (4) M6x16mm Screws to assemble the Rear Handle as shown.

Step 6

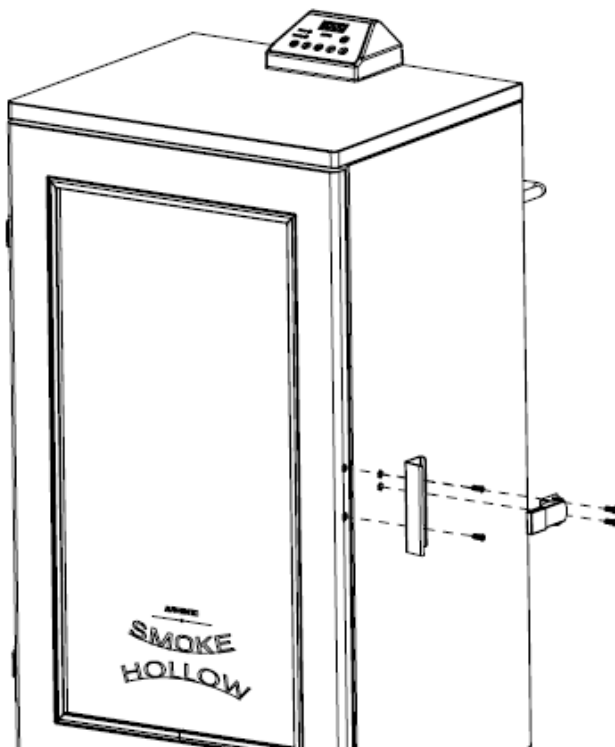

Locate:

- Door Latch Assembly
- Door Handle
- (4) M4 x 12 Screws

Tools Needed:

Phillips Screwdriver

Procedure:

Use (4) M4x12mm Screws to assemble the Door Latch Assy and Door Handle as shown.

Smoker Assembly

Step 7

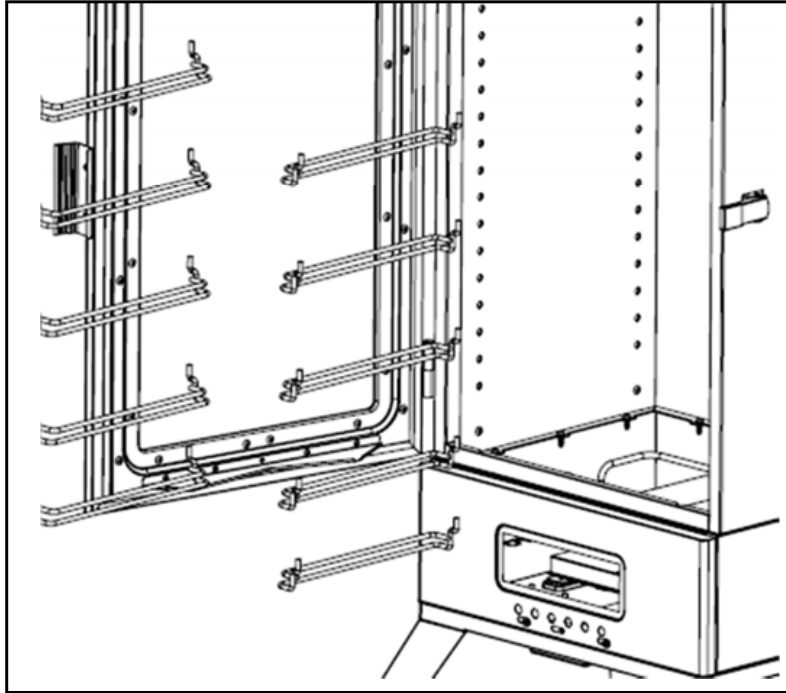

Locate:

- (10) Grid Supports
- Heat Tent
- Water Pan
- Water Pan Support

Tools Needed:

None

Procedure:

Attach (10) Grid Supports in the holes on each side of the smoker. Make sure the Grid Supports line-up at the same height so the cooking grids are level.

Place the Heat Tent on top of Rails as shown.

Place the Water Pan and Water Pan Support into the Grid Supports as shown below.

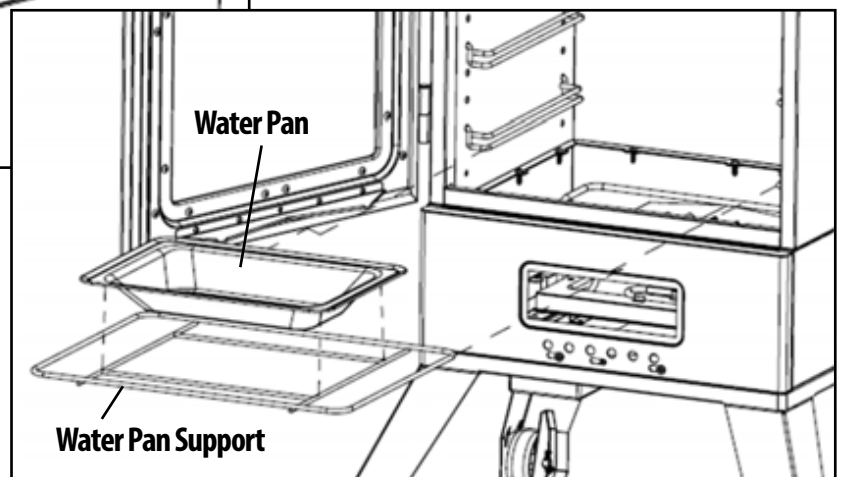
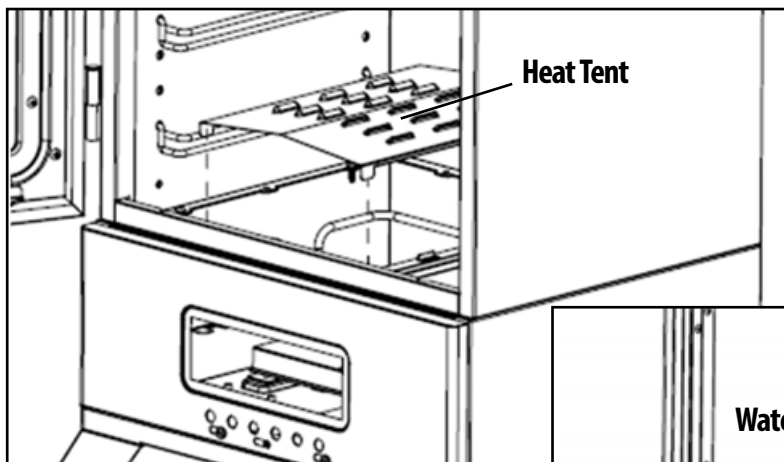

Smoker Assembly

Step 8

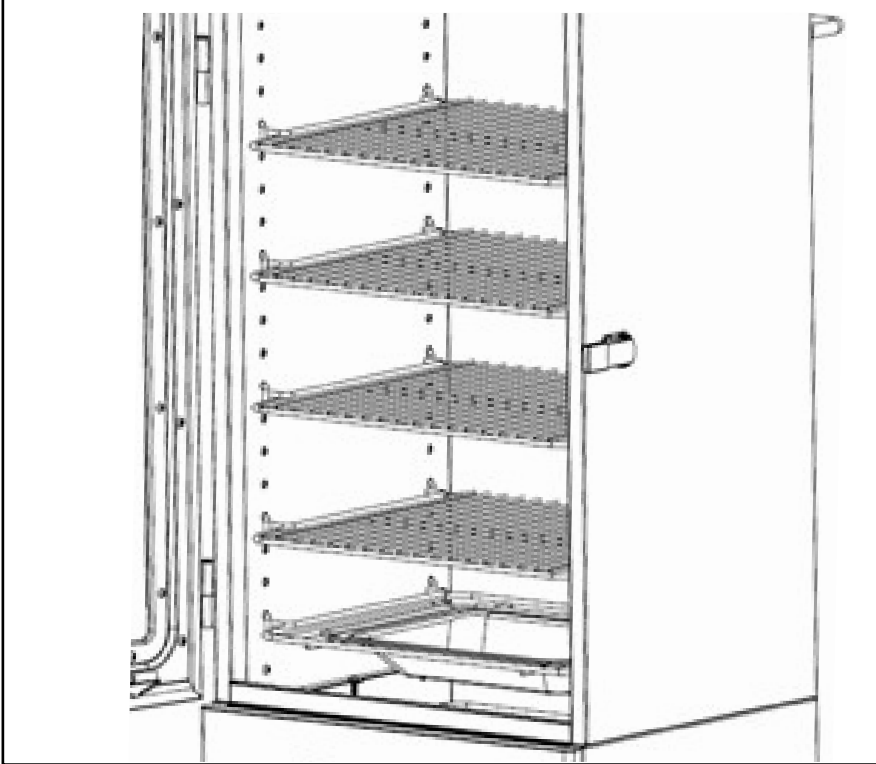

Locate:

- (4) Cooking Grids

Tools Needed:

None

Procedure:

Place the (4) Cooking Grids into the Cooking Grid Supports as shown. Make sure the angled portion of the grid is slid in first.

Step 9

Procedure:

Slide the Wood Chip Tray & Lid Assembly into the Rails in the smoker. Slide the Grease Tray into the smoker as shown. Screw the Vent Knob to the Front Vent as shown.

Locate:

- Wood Chip Tray
- Wood Chip Tray Lid
- Grease Tray
- Vent Knob

Tools Needed:

None

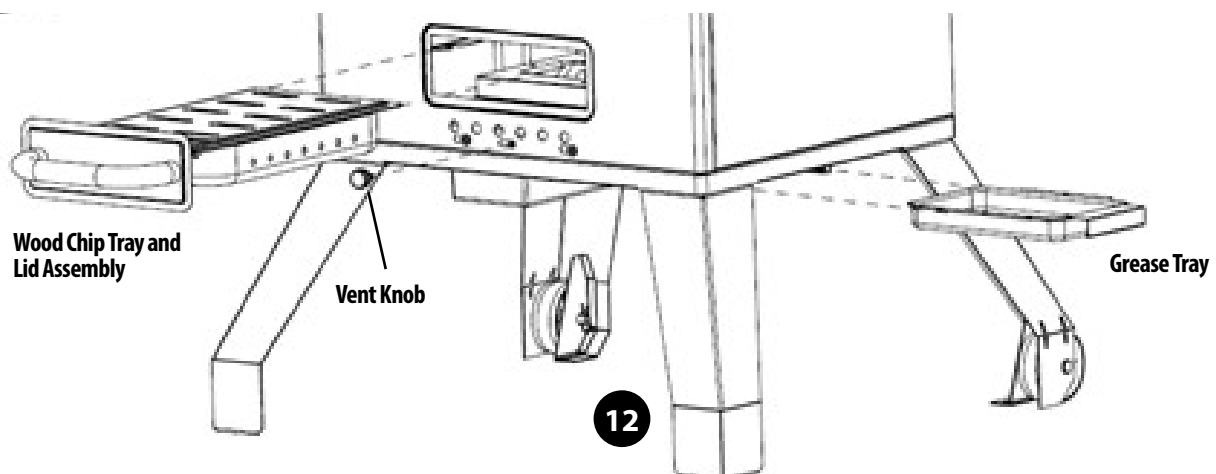

Wood Chip Tray and Lid Assembly

Vent Knob

Grease Tray

Smoker Assembly

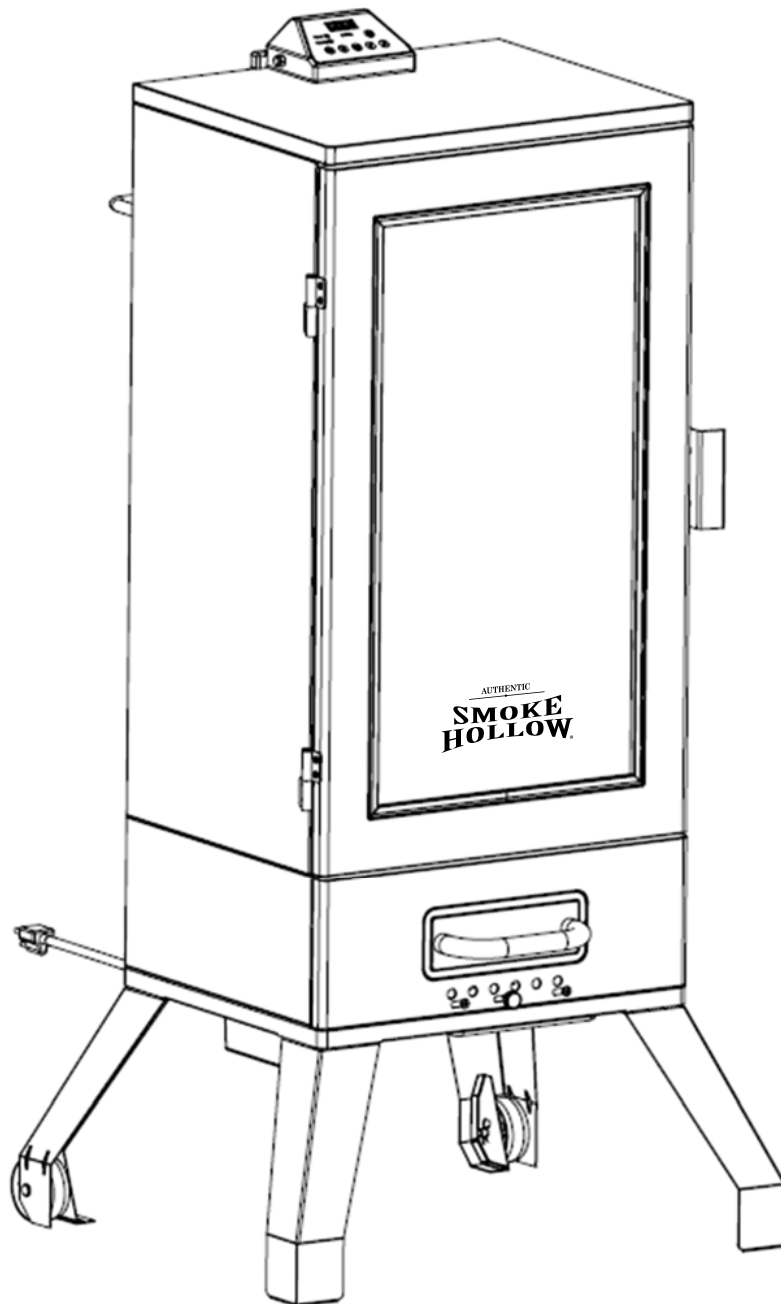

**ASSEMBLY OF YOUR SMOKER IS NOW COMPLETE.
FOR YOUR SAFETY, FOLLOW ALL SAFE GUARDS
AND INSTRUCTIONS.**

Seasoning Instructions

SEASON YOUR SMOKER PRIOR TO ITS FIRST USE.
SOME SMOKE MAY APPEAR DURING THIS TIME. THIS IS NORMAL
DURING THE SEASONING PROCESS.

1. Make sure water pan is in place with NO WATER.
2. Set the temperature to 275°F, set the time for 3 hours and turn the smoker on.
3. To complete the seasoning process, add wood chips to the wood chip pan during the last 45 minutes.

Caution: Never overfill the wood chip tray. Make sure the wood chip tray lid closes completely on the wood chip tray.

4. Shut the unit off and allow to cool.

How to Use The Wood Chip Tray

1. Before starting the unit, open the lid and fill the wood chip tray with wood chips.

Caution: Never overfill the wood chip tray. Make sure the wood chip tray lid closes completely on the wood chip tray.

2. Never use wood chunks or wood pellets in the wood chip tray.
3. Insert the wood chip tray into the opening in the smoker.
4. Check the wood chip tray periodically to see if the wood has burned down by sliding the wood chip tray out about half way and looking through the slots in the wood chip tray lid to see if the wood has burned down.
5. If the wood chips have completely burned in the wood chip tray, remove the tray from the smoker.

Caution: The wood chip tray and lid will be HOT, even if the handle is not.

6. Dump the burned wood chips from the wood chip tray. The wood chip tray lid will stay attached to the wood chip tray during this process. Always dump the burned wood chips in a metal pan with water to extinguish the wood chips.
7. With the wood chip tray lid open, fill the wood chip tray with wood chips. Close the lid.

Caution: Never overfill the wood chip tray. Make sure the wood chip tray lid closes completely on the wood chip tray.

8. Insert the wood chip tray into the opening in the smoker

CAUTION:

- Keep the smoker door closed when dumping or adding wood chips.
- The wood chip tray and lid will be HOT even if the handle is not.
- Never use wood pellets or wood chunks.

CAUTION

WHEN DOOR IS OPENED A FLARE UP MAY OCCUR. SHOULD WOOD CHIPS FLARE UP, IMMEDIATELY CLOSE DOOR, WAIT FOR WOOD CHIPS TO BURN DOWN THEN OPEN DOOR AGAIN. DO NOT SPRAY WITH WATER.

Important Facts for Using Smoker

- Maximum temperature setting is 300°F (149°C).
- Do NOT move unit across uneven surfaces.
- Rear handle is NOT for lifting.
- Wood chip tray lid MUST be in place when using smoker. This minimizes the chance of wood flare ups.
- Wood chips must be used in order to produce smoke and create the smoke flavor.
- Check grease tray often during cooking. Empty grease tray before it gets full. Grease tray may need to be emptied periodically during cooking.
- Do not open smoker door unless necessary. Opening smoker door causes heat to escape and may cause wood to flare up. Closing the door will re-stabilize the temperature and stop flare up.
- If a flare up occurs in your wood chip tray, leave the door closed and close the lower air intake vent until flare up stops. If the flare up continues for 10 or more minutes, shut the smoker off to allow the flare up to stop.
- Do not leave old wood ashes in the wood chip tray. Once ashes are cold, empty tray. Tray should be cleaned out prior to, and after each use to prevent ash buildup.
- Glass in door is tempered and will not break under normal operation.
- This is a smoker. There will be a lot of smoke produced when using wood chips. Some smoke may escape through seams and turn the inside of smoker black. This is normal. To minimize smoke loss around door, the door latch can be adjusted to further tighten door seal against body.
- Opening smoker door during cooking process may extend cooking time due to heat loss.
- When outside temperature is cooler than 65°F (18°C) and/or altitude is above 3,500 feet (1067m), additional cooking time may be required. To ensure that meat is completely cooked use a meat thermometer to test internal temperature.
- To adjust door latch, loosen hex nut on door latch. Turn hook clockwise to tighten. Secure hex nut firmly against door latch.

How to Clean Smoker

- For the grid tracks, cooking grids, water pan and grease drip pan, use a mild dish detergent. Rinse and dry thoroughly.
- For the wood chip tray, clean frequently to remove ash build up, residue and dust.
- Dispose of cold ashes by placing them in aluminum foil, soaking with water and discarding in a non-combustible container.
- For the interior (glass in door and meat probe) and exterior of the smoker, simply wipe down with a damp cloth. Do not use a cleaning agent. Make sure to dry thoroughly.
- Door seal and inside seam that seal attaches to MUST be cleaned with a damp cloth after each use to keep seal in proper working condition.

ALWAYS MAKE SURE UNIT IS UNPLUGGED AND COOL TO THE TOUCH BEFORE CLEANING AND STORING.

Operating Instructions

Control Panel Functions

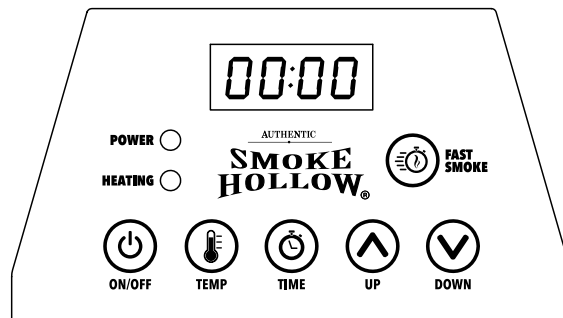

The **POWER** button powers the unit on. When the power cord is plugged in, the green LED light will flash indicating the unit has power. When the POWER button is pushed the unit will turn on and the light will stay on.



When the **FAST SMOKE** button is pressed the LED will light solid while the program is in operation. The FAST SMOKE button serves (2) functions. The first is to get the wood chips smoking faster when you are in either of the smoking programs. The second is to get the wood chip drawer with new wood chips started faster after dumping burned up wood chips. The FAST SMOKE can be used anytime after the initial 15 minutes during the smoking functions. The FAST SMOKE mode will be on for 15 minutes. You will see the LED display show the 15 minutes counting down to zero. Your current smoking program is still running in the background during the 15 minutes the FAST SMOKE is in use. After the 15 minutes the smoking program will resume. You can stop the FAST SMOKE at any time during the running of the program by pressing the FAST SMOKE button again.



The **TIME** button allows you to set your smoking time from 10 minutes to 99 hours. You are also able to check the time left to smoke during any smoke program by pressing the TIME button once. Your time will change in 1 hour increments with pressing the button one time. After you have set your hours, if you press the TIME button again you will be able to set the minutes for your smoking cycle. Your minutes will change in 10 minute increments.



The **TEMP** button allows you to set your desired smoking temperature in the smoking programs. You will be able to set your temperature range in the Smoking program between 100°F and 300°F. You are able to check your internal temperature inside the smoker at any time during any of the smoking programs by pressing the TEMP button once. Your temperature will change in 5°F increments when setting the internal smoker temperature.



The **UP/DOWN** buttons allow you to change the time and temperature up and down accordingly. When you press the UP/DOWN button, the time will change in 1 hour increments or 10 minute increments and the temperature will change in 5°F increments. If you push and hold the UP/DOWN button for 3 seconds or more, the time and temperature will scroll at a faster rate.



The **DIGITAL LED SCREEN** is your information center for the smoker. The LED screen will display your Time, Cabinet Temp., and Probe Temp. (if connected). When you have chosen a smoking mode and set your information, the LED screen will scroll between Time, Cabinet Temp. and Probe Temp. during the smoking cycle.

Example: Screen Displays w/o Meat Probe

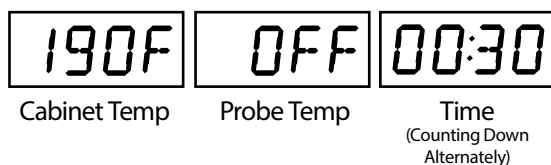

Example: Screen Displays with Meat Probe

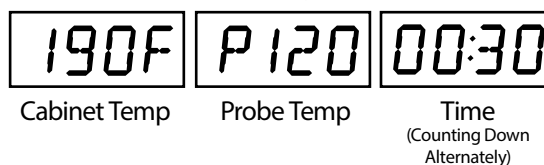

MEAT PROBE (Optional) - Sold separately

Your smoker has a jack connector on the side of the controller for a meat probe. Make sure to insert the silicon plug into the jack connector to prevent water getting into the controller.

(Note: Any other branded meat probe besides a Smoke Hollow 230KΩ Meat Probe, may not work accurately with this smoker.)

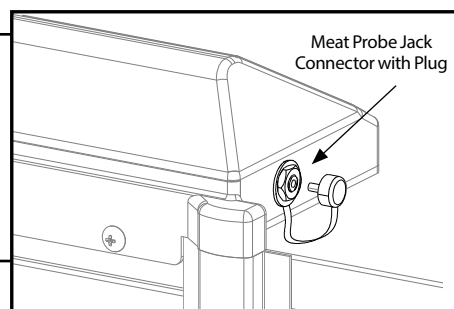

Operating Instructions

1. Plug the power cord into a GFI Outlet. The green indicator light for POWER will turn on indicating there is power to the smoker.
2. Fill water pan half full with water or your choice of liquid.
3. Fill the wood chip tray with wood chips. Refer to the section "How to use the wood chip tray" on page 14
4. Press the "TEMP" button to set the desired temperature inside the smoker.
 - Press the UP or DOWN button to increase or decrease temperature.
5. Press the "TIME" button to set the smoking cycle time.
 - Press the button once to set hours.
 - Press the UP or DOWN button to increase or decrease the hours.
 - Press the button again to set minutes.
 - Press the UP or DOWN button to increase or decrease the minutes.
 - Press the TIME button to start the smoking program.
6. Your wood chips should start to smoke in 10-15 minutes depending on the type of wood chips. After 20 minutes your wood chips should "Wick" and continue to smoke for the rest of the program cycle. See below for recommended settings for both of the air intakes (Vents) on the smoker.

NOTE: If at any time you press the Time or Temperature button during a smoke program, the display will change to the current time remaining or the current cabinet and probe temperature (if probe is being used). By holding the Time or Temp button for 3 seconds during the smoke cycle, the LED will flash the current set time or temperature. The time or temperature can be changed by using the up and down arrows as defined above. The change can be confirmed by pressing the Time or Temperature button a second time.

FAST SMOKE OPERATION

If you feel your wood chips are not producing enough smoke after the initial 15 minutes or you are adding fresh wood chips, you can press the "Fast Smoke" button and the smoke element will run for an additional 15 minutes to help get the wood chips smoking. On the LED screen, you will see the time counting down from 15 minutes to 0 minutes.

Note: You can stop the "Fast Smoke" program at anytime by pressing the "Fast Smoke" button while the program is running.

When the program time runs out, the LED will read "DONE". The smoker will still be running and the LED screen will display the remaining program time and temperature.

AIR INTAKE SETTINGS

You can set your Air Intake to any opening to achieve the optimal smoke you desire. These are recommended settings to help your chips to last longer and have optimal smoke generated. (Your settings may vary depending on the size of the wood chips used and the density of the wood chips in the wood chip tray.)

Bottom Air Vent

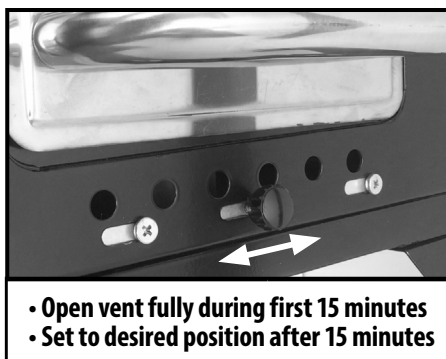

Back Air Vent

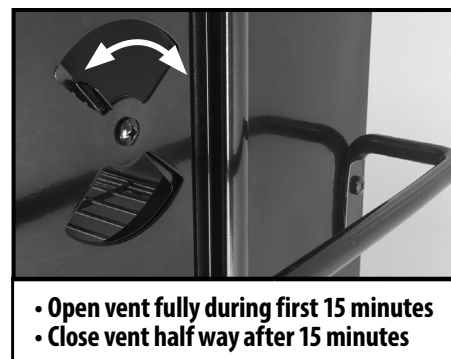

NOTE: If your wood chips are producing more smoke than you want, you can slow the smoke being produced by decreasing the lower air intake vent opening to restrict the incoming air.

Troubleshooting Guide

SYMPTOM	CAUSE	SOLUTION
No Power to controller	Not plugged into outlet	Plug into power source
	House breaker tripped	Reset breaker
	Bad connection at controller	Unplug connection and reconnect.
	Bad connection at PCB (Power Control Board)	Unplug connection and reconnect.
	Faulty PCB (Power Control Board)	Call OLPI for replacement.
	Faulty Controller	Call OLPI for replacement.
	Faulty body wiring	Call OLPI for replacement.
Power light not on	Appliance not powered on	Press on/off button
	Faulty controller	Call OLPI for replacement.
No display on controller (Power light is on)	Controller temp is below -10°F (-23°C)	Remove controller from unit and bring to temp above 0°F (-18°C).
	Faulty controller	Call OLPI for replacement.
Heating light not on	Temp and time not set	Set Temp and Time, wait 60 seconds for heating light to turn on.
	Faulty controller	Call OLPI for replacement.
	Faulty body wiring	Call OLPI for replacement.
Element not on	Bad connection at the element	Unplug connection and reconnect.
	Faulty element	Call OLPI for replacement.
Meat Probe (Optional) does not read on controller	Bad connection at the meat probe	Unplug connection and reconnect.
	Faulty meat probe	Call OLPI for replacement.
	Faulty controller	Call OLPI for replacement.

Troubleshooting Guide

SYMPTOM	CAUSE	SOLUTION
Cabinet Temp is inaccurate	Faulty Temp Sensor	Call OLPI for replacement.
	Faulty controller	Call OLPI for replacement.
Appliance takes excessive amount of time to heat	Climate	Temps below 65°F (18°C) may extend heating time
	Appliance plugged into an extension cord	Plug appliance directly into power source. Maximum length ext. cord 25ft, min. gauge 12/3.
	Door not closed properly	Close door and adjust latch so door seals completely
	Waterbowl/ Drip deflector not properly located	Locate waterbowl/drip deflector properly on supports. See assembly steps for proper installation
	Faulty controller	Call OLPI for replacement.
Gap between the door and smoker	Door alignment	Adjust door hinges
	Damaged door seal	Call OLPI for replacement door kit
Grease leaking from smoker	Door not closed properly	Close door and adjust latch so door seals completely around appliance.
	Appliance not level	Move appliance to level surface and adjust height
	Drip pan not in proper location	Align drip pan so drain hole in pan and smoker align
	Grease tray is full	Empty grease tray and reinstall under smoker
	Drain tube is clogged	Clean drain tube
No smoke	No wood chips	Add wood chips. (See adding wood chips guide)
	Element not staying on long enough to heat chips due to climate	1. Open vent fully. 2. Open door briefly to allow smoker temp to drop approx. 5°F (2.78°C) below set temp then close door.
	Damaged smoke box	Call OLPI for replacement.
Controller will not adjust temp	Faulty controller	Call OLPI for replacement.
Controller will not adjust time	Faulty controller	Call OLPI for replacement.
Error Code: Err2	Cabinet temperature > 370F	The Heat Element will automatically shut off when the temperature is higher than the setting temperature. Call OLPI for replacement
Error Code: Err	Thermostat probe is damaged/short circuited	Call OLPI for replacement

Smoking Tips

Types of wood to use for smoke:

- Always use a hardwood that has been seasoned for at least 6 months.
- We recommend using Pecan, Hickory, White Oak, Apple, Alder or Mesquite.
- Never use any resin woods like Pine or Cedar.

Note: It is not necessary to soak the wood prior to smoking because hard woods have natural moisture in the wood that will release in the smoker as it heats up. In a gas smoker, soaking the wood chips may prolong the life of the wood chips but it will also take longer to produce smoke so we will leave that decision up to you. Do not soak your wood chips when using your Smoke Hollow electric smoker.

What you need to smoke meats:

Internal Meat Thermometer

An internal meat thermometer is a must to cook large pieces of meat to make sure it is done internally.

Internal Temperatures for Select Meats

- Cooked Ham - 140 degrees
- Ham, Beef-Med, Ground Beef - 160 degrees
- Veal, Lamb, Pork, Beef-Well done - 170 degrees
- Poultry - 180 degrees

Good Tongs or Meat Hook

Use a heavy-duty set of tongs to rotate meat in the smoker because in some cases you may be smoking a very large cut of meat. I prefer a meat hook for ease of use and it does not knock any rub or sauce off of the meat.

Good Oven Mitts

Heavy-duty mitts will assist you in moving hot smoker racks and large pieces of meats and assist in adding water and wood chips.

Aluminum Foil

When the outside color of your meat product is at your desired color or look to suit your taste, wrap meat product in aluminum foil to keep any more wood resins from turning your meat any darker. Also it will saturate fats from your meat product.

Smoking Techniques

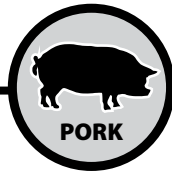

Smoked Pork Tenderloin

Take outside wrapper off of meat and wash thoroughly in cold water. Place tenderloin on a paper towel to soak up excess water. Rub your favorite pork rub on the loin (we recommend Head Country Pork seasoning). Preheat smokers to 225 degrees and place loin in the center of the smoker. Cook until internal meat temperature reaches 165 degrees. Take out of smoker and let stand on the cutting platter until meat reaches 170 degrees serving temperature. Slice like bread in 1/4" pieces and it will melt in your mouth.

Pork Ribs- Baby Backs or Spare Ribs

Take ribs out of wrapper and drain all liquid off of the ribs and then wash in cold water. Place on cutting board and cut away any excess fat or skin from the bottom of ribs. Turn ribs with bone side up and peel the membrane from the back of the bone until all is gone. Rub your favorite pork rub on both sides of the ribs (we recommend Head Country Pork seasoning). Preheat smoker until it reaches 225 degrees and place rib bone side down in smoker. After one hour, turn the rib over with bone side up and cook for one hour. After 2 1/2 hours, depending on the color of the rib you like, pour a one inch wide strip of your favorite BBQ sauce down the length of the rib and wrap tightly in aluminum foil. Place back in smoker and check every 15 to 20 minutes to see if the rib bones separate by using your finger to pull them apart. If they pull apart with ease your ribs are done. Note: Make sure your internal temperature of your ribs are at 170°F. Take out of smoker and let stand on serving platter until cool enough to eat.

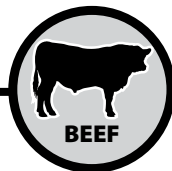

Smoked Beef Brisket

Select a 6 to 8 lb. packer trimmed brisket that has a little marble to it but not too much. Feel free to trim as much fat as desired. Use your favorite beef rub (we recommend using Head Country All-Purpose rub) and rub it on liberally. Heat the smoker to 225 degrees and place the brisket in the smoker for 3 hours. Place brisket in an aluminum foil pan and pour approximately 8oz. of Allegro over the brisket. Cover the pan tightly with aluminum foil and continue cooking until internal meat temperature reaches 165 to 170 degrees. Take pan out of the smoker and let brisket stand. Remove brisket from pan and cut 1/4" slices against the grain. Use juice from pan to pour over sliced meat or for dipping.

Prime Rib

Select a 6 to 8 lb prime rib (we like the bone on). Rub the prime rib with your favorite beef rub (we recommend using Head Country All-Purpose rub). Pre-heat the smoker to 225 degrees and place the prime rib in the smoker. After 3 hours, place the prime rib in aluminum foil pan and cover with aluminum foil. When internal meat temperature reaches 145 degrees take out of smoker and let stand until your desired doneness is reached. Medium rare is 155 to 160 degrees. While standing, the temperature of the meat will rise internally up to 10 degrees. Slice prime rib to desired thickness and serve with juice from the pan in which it was cooked.

Smoking Techniques

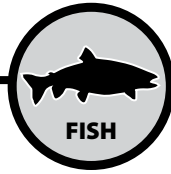

Smoked Halibut

Select a nice fresh $\frac{3}{4}$ " thick filet. Wash filet thoroughly in cold water and lay on paper towel until water is not visible. Melt a whole stick of butter in the microwave and sprinkle a liberal amount of Dill weed in the melted butter. Lay filets on aluminum foil and fold a lip around edges to contain the butter. With a basting brush, brush melted butter and dill weed mixture on both sides of the fish filet. Preheat smoker to 225 degrees and place fish in the smoker. Check the filets every 15 minutes for visible moist look on filets. Brush with butter and dill weed mix when needed. Fish should start to flake in about 45 minutes. When fish flakes very easy take out of smoker and serve.

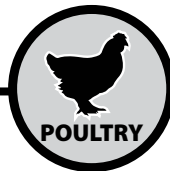

Smoked Chicken

Chicken breasts and thighs are my favorite. Take chicken parts out of package and wash thoroughly and place on paper towel to dry. Sprinkle Head Country Original rub on both sides of chicken parts. Preheat smoker to 225 degrees and place chicken parts in smoker. After $\frac{1}{2}$ hour turn chicken over. With your internal temperature gauge, check internal temperature by pushing temperature probe into the meat nearest the bone. When temperature reaches 180 degrees chicken is done. You may brush your favorite BBQ sauce on the chicken during the last 15 minutes of your cooking process to spice it up.

Smoked Turkey

Select a 12 to 15 lb. turkey for best results in a smoker. Take the turkey out of the package and remove all internal parts and packaging. Wash turkey thoroughly and place it on paper towel to dry. Rub olive oil inside and out on the turkey and apply Head Country Original Rub inside body cavity and on the outside skin. Preheat smoker to 225 degrees and place turkey in smoker. You may baste with butter for more moisture, if you like. When turkey skin reaches your desired color, remove turkey from smoker, place in aluminum foil pan and cover with aluminum foil tightly. Place covered pan in smoker and continue cooking at 225 degrees. Check internal meat temperature, where the thigh meets the side of the turkey, every half hour for doneness. Turkey should take around 45 minutes per lb to reach 180 degrees serving temperature.

Cold Smoking Recipes

Smoked Cheddar Cheese

Ingredients

Brick of Cheddar Cheese (Old or Aged cheddar is preferred - substitute Gouda or Fontina for a change of flavor.

Preparation

Place cheese on racks and load into your Smoke-Tronix smoker by Smoke Hollow®.

Smoking Method

1. Fill the wood chip tray with your favorite wood chips.
2. Open the back and lower vents completely.
3. Push the fast smoke button and set your time, temp and probe if desired.
4. It is best to keep the internal temp lower than 100° F when smoking cheese.
5. If the internal temp is too hot, you may need to place a pan of ice under your cheese rack to help reduce the internal temp or open the door slightly.
6. Smoke for approximately 40 to 60 minutes.

Cold Smoked Salmon Serves 8-10 as an appetizer

Ingredients

2 to 3 pounds fresh salmon fillet (preferably from the head end)
1 1/2 cups coarse sea salt or kosher salt
1 1/2 cups brown sugar

Optional Garnishes

Diced red onion, Sliced lemons, Chopped fresh dill or Sour cream

Preparation

1. Run your fingers over the flesh side of the salmon fillets, feeling for the sharp ends of pin bones. Pull out any you find with fish tweezers or needle nose pliers.
2. Make the cure: Combine the salt and brown sugar in a mixing bowl and mix with your fingers. Spread 1/3 of the cure over the bottom of a glass baking dish just large enough to hold the fish. Lay the salmon fillets on top of the cure. (The cure should extend 1/2 inch beyond the edges of the fish on each side.) Spread the remaining cure on top so it covers the fish completely.
3. Cover the dish with plastic wrap and cure the fish in the coolest part of your refrigerator for 24 to 48 hours.
4. Gently rinse the cure off the salmon under cold running water. Place the salmon in a large bowl with cold water to cover by 3 inches. Soak for 30 minutes, then drain well in a colander.
5. Blot the salmon dry on both sides with paper towels. Arrange it skin side down on a wire rack over a sheet pan. Let the salmon dry, uncovered, in the refrigerator until it feels tacky, about 4 hours.

Smoking Method

1. Fill the wood chip tray with your preferred flavor of wood chips. Beechwood or Alder are good choices for salmon.
2. Open the back and lower vents completely.
3. Push the fast smoke button and set your time, temp and probe if desired.
4. If the internal temp goes above 100°, you may need to place a pan of ice under your salmon rack to help reduce the internal temp or open the door slightly.
5. Cold smoke the salmon until the exterior is bronzed with smoke and the salmon feels semi-firm and leathery, 12 hours or more. How will you know it's ready? Cut a slice from next to the skin at the fat end.
6. Wrap salmon in uncoated butcher paper and let rest in the refrigerator for at least 4 hours before serving or overnight.
7. Using a long, slender and sharp knife held sharply on the diagonal to the fish, cut the salmon into paper-thin slices.

Limited Warranty

This Smoke Hollow® smoker is guaranteed against broken or damaged parts at time of purchase. All parts carry a 1-year limited warranty. Paint is guaranteed to be free of defects for 90 days except for rust, which may appear after repeated use.



This warranty does not cover damage or issues related to neglect, abuse, or modifications to the product. Repair labor is not covered.

All parts that meet the warranty requirements will be shipped at no-charge via the discretion of the Customer Service Department (ground shipments, US Mail, or Parcel Post Only). Any special handling charges (i.e. Second Day, Overnight, etc.) will be the responsibility of the consumer.

All warranty claims apply only to the original purchaser and require a proof of purchase verifying purchase date. Do not return parts to our address without first obtaining a return authorization number from our customer service.

This service is available by calling 866-475-5180, 8:30am to 4:30pm, Central Time, Monday through Friday, or write to Outdoor Leisure Products, Inc., 5400 Doniphan Drive, Neosho, MO 64850.

This warranty may give you specific legal rights that vary by state.

Outdoor Leisure Products, Inc
5400 Doniphan Drive
Neosho, MO 64850
www.olp-inc.com