

This Owner's Manual is provided and hosted by [Appliance Factory Parts](#).

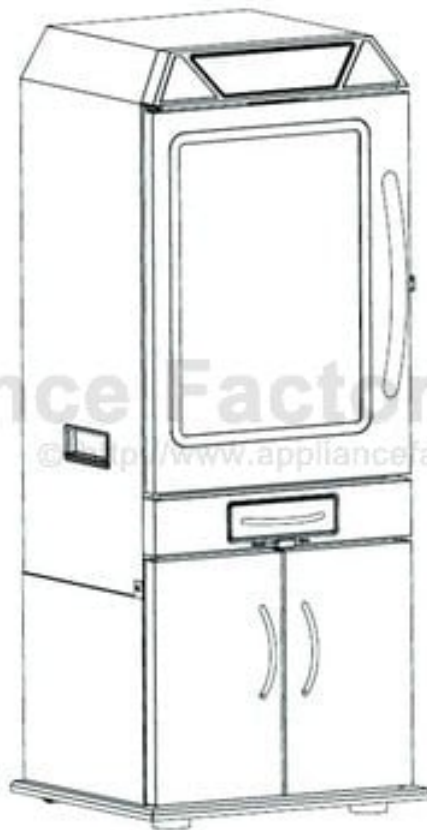

# Smoke Hollow D4015SSC Owner's Manual

[Shop genuine replacement parts for Smoke Hollow  
D4015SSC](#)



[Find Your Smoke Hollow Grill Parts - Select From 115 Models](#)

----- Manual continues below -----

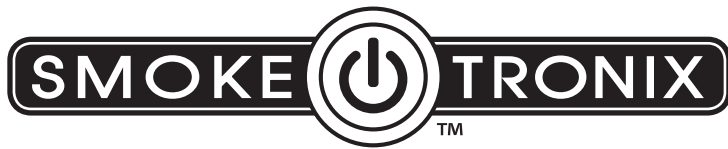

# Digital Electric Smoker with Cabinet

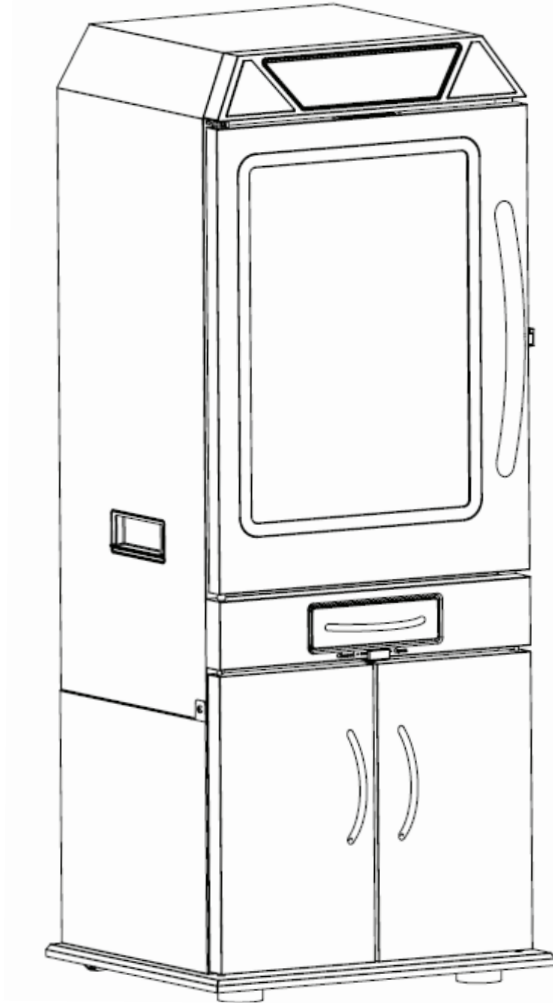

For Models  
**D4015SSC / D4015BC**  
and **D4015RC**



**THIS IS YOUR ASSEMBLY, CARE & USE MANUAL  
WITH IMPORTANT WARNING & SAFETY INFORMATION.  
PLEASE SAVE THESE INSTRUCTIONS.**

Approximate assembly time: 30 minutes  
Tools needed for assembly: Phillips head screwdriver

---

**FOR OUTDOOR USE ONLY**

# **WARNING**

THIS MANUAL CONTAINS IMPORTANT INFORMATION NECESSARY FOR THE PROPER AND SAFE USE OF THIS UNIT. READ AND FOLLOW ALL WARNINGS AND INSTRUCTIONS BEFORE USING SMOKER AND DURING USE.

**FAILURE TO FOLLOW THESE WARNINGS AND INSTRUCTIONS PROPERLY  
COULD RESULT IN PERSONAL INJURY OR DEATH.**

# **CARBON MONOXIDE HAZARD**

BURNING WOOD CHIPS GIVES OFF CARBON MONOXIDE, WHICH HAS NO ODOR AND CAN CAUSE DEATH. DO NOT BURN WOOD CHIPS INSIDE HOMES, VEHICLES, TENTS, GARAGES OR ANY ENCLOSED AREAS. USE ONLY OUTDOORS WHERE IT IS WELL VENTILATED.

# **IMPORTANT SAFEGUARDS**

## **READ ALL INSTRUCTIONS**

- Do not leave smoker unattended.
- Do not cover cooking racks with metal foil. This will trap heat and cause severe damage to the electric smoker.
- Drip tray is only for the bottom of electric smoker. Do not put drip tray on cooking rack as this may damage the electric smoker.
- The wood chip tray is HOT when electric smoker is in use. Use caution when handling or adding wood.
- To disconnect, turn control panel "OFF" then remove plug from outlet.
- Unplug from outlet when not in use and before cleaning. Allow unit to cool completely before adding/removing grates, wood chip tray or water pan.
- Dispose of cold ashes by placing them in aluminum foil, soaking with water and discarding in a non-combustible container.
- Do not store the electric smoker with HOT ashes inside unit. Store only when all surfaces are cold.
- Accessory attachments or parts not supplied by Outdoor Leisure Products, Inc. are not recommended and may cause injury.
- Never use the electric smoker for anything other than its intended purpose. This unit is not for commercial use.
- Always use the electric smoker in accordance with all applicable local, state and federal fire codes.
- Longer, detachable power-supply cords or extension cords are available and may be used if care is exercised in their use, based on the following requirements.
- If a longer, detachable power-supply cord or extension cord is used, the marked electrical rating of the cord set or extension cord should be at least as great as the electrical rating of the appliance.
- The extension cord must be a grounding -type 3-wire cord.
- Outdoor extension cords must be used with outdoor use products and are marked with suffix "W" and with the statement "Suitable for Use with Outdoor Appliances."
- CAUTION- To ensure continued protection against risk of electric shock, connect to properly grounded outlets only.
- CAUTION - To reduce the risk of electric shock, keep extension cord connection dry and off the ground.
- Do not clean this product with a water sprayer or the like.
- Do not use wood pellets or wood chunks.
- Store products indoors when not in use - out of reach of children.

**CONTINUED ON  
NEXT PAGE...**

# **IMPORTANT SAFEGUARDS**

## **When using electrical appliances, basic safety precautions should always be followed including the following:**

- For outdoor use only. Do not operate in an enclosed areas (example, porch or garage).
- Unit **MUST** be on the ground. Do not place unit on tables or counters. Do **NOT** move unit across uneven surfaces.
- Do not lift unit by rear handle.
- Do not plug in the electric smoker until fully assembled and ready for use.
- Use only an approved grounded electrical outlet.
- Do not use during an electrical storm.
- Do not expose the electric smoker to rain or water at anytime.
- **CAUTION-** To ensure continued protection against risk of electric shock, connect to properly grounded outlets only.
- To protect against electrical shock do not immerse cord, plug or control panel in water or other liquid.
- Do not operate any appliance with a damaged cord or plug, or after appliance malfunctions or has been damaged in any manner. Contact OLPI Customer Service for assistance at 1-866-475-5180.
- Keep a fire extinguisher accessible at all times while operating the electric smoker.
- Do not let cord touch hot surfaces.
- Do not place on or near a hot gas or electric burner, or in a heated oven.
- Keep children and pets away from electric smoker at all times. Do not allow children to use electric smoker. Close supervision is necessary should children or pets be in area where the electric smoker is being used.
- Fuel, such as charcoal briquettes or heat pellets, are not to be used in the electric smoker.
- Never use the electric smoker as a heater (**READ CARBON MONOXIDE HAZARD ON PAGE 2**).
- Use the electric smoker only on a level, stable surface to prevent tipping.
- The electric smoker is **HOT** while in use and will remain **HOT** for a period of time afterwards. Use caution.
- Do not touch **HOT** surfaces. Use handles or knobs.
- Do not allow anyone to conduct activities around the electric smoker during or following its use until the unit has cooled.
- The use of alcohol, prescription or non-prescription drugs may impair the user's ability to properly assemble or safely operate the electric smoker.
- Avoid bumping or impacting the electric smoker.
- Never move the electric smoker when in use. Allow the smoker to cool completely before moving or storing.
- Be careful when removing food from the electric smoker. All surfaces are **HOT** and may cause burns. Use protective gloves or long, sturdy cooking tools.
- Avoid using the smoker on wooden or flammable surfaces.
- Store products indoors when not in use - out of reach of children.

**SAVE THESE  
INSTRUCTIONS**

## **WARNING**

### **CALIFORNIA PROPOSITION 65**

This product contains, or the use of this product releases, chemicals known to the State of California to cause cancer and birth defects or other reproductive harm. For more information go to [www.P65Warnings.ca.gov](http://www.P65Warnings.ca.gov).



# ***Congratulations***

on your purchase of your new  
Smoke Hollow® Digital Electric Smoker.

With proper set-up, operation and maintenance, this appliance will provide you with years of delicious food and cooking enjoyment.

## **IMPORTANT**

**When you un-pack your smoker, remove all parts and packaging material from the box and inside the smoker. Make sure you have all the items on the parts list. Carefully check the unit and make sure there is no damage.**

**IF YOU HAVE ANY PROBLEMS WITH THIS PRODUCT OR THERE ARE MISSING OR DAMAGED PARTS , PLEASE CALL CUSTOMER SERVICE TOLL FREE 1-866-475-5180 (Monday–Friday, 8:30 am–4:30 pm, CST).**

**NOTE : DO NOT RETURN UNIT TO THE STORE BEFORE CALLING THE TOLL FREE NUMBER.  
Do not dispose of your cartons until you are completely satisfied with your new Smoke Hollow smoker.**

### **THIS DEVICE COMPLIES WITH PART 15 OF THE FCC RULES**

**Warning:** Changes or modifications to this unit not expressly approved by the party responsible for compliance could void the user's authority to operate the equipment.

NOTE: This equipment has been tested and found to comply with the limits for a Class B digital device, pursuant to Part 15 of the FCC Rules. These limits are designed to provide reasonable protection against harmful interference in a residential installation. This equipment generates uses and can radiate radio frequency energy and, if not installed and used in accordance with the instructions, may cause harmful interference to radio communications. However, there is no guarantee that interference will not occur in a particular installation. If this equipment does cause harmful interference to radio or television reception, which can be determined by turning the equipment off and on, the user is encouraged to try to correct the interference by one or more of the following measures:

- **Reorient or relocate the receiving antenna.**
- **Increase the separation between the equipment and receiver.**
- **Connect the equipment into an outlet on a circuit different from that to which the receiver is connected.**
- **Consult the dealer or an experienced radio/TV technician for help.**

# Parts and Tool List

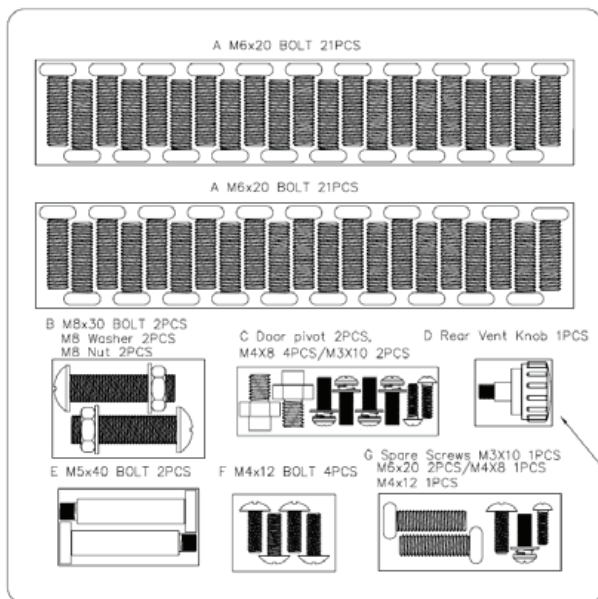
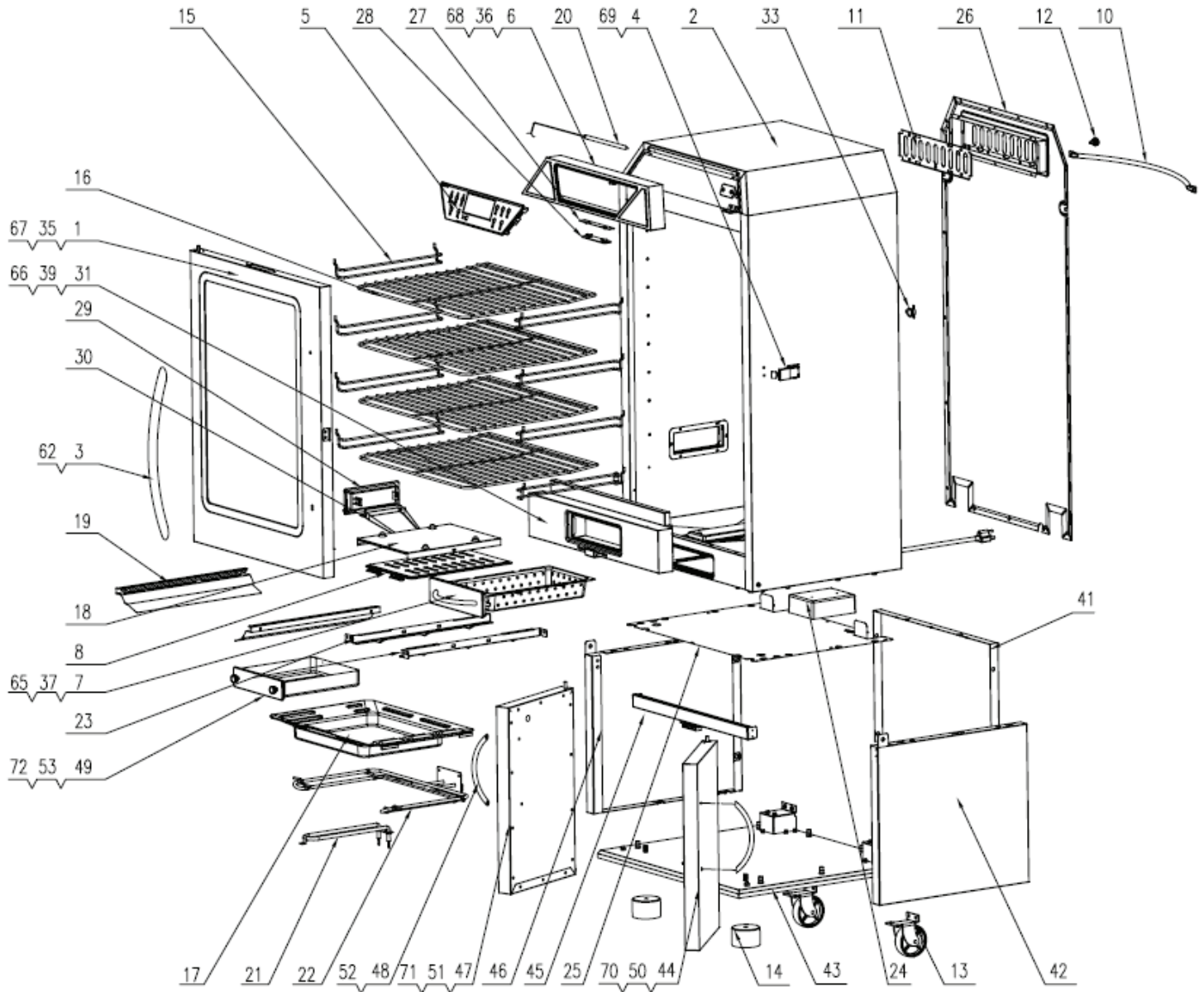

Tools needed for assembly:  
**Phillips head screwdriver**

# Parts and Tool List

Note: For assistance, including missing or damaged parts, call toll free 1- 866-475-5180 from 8:30 am - 4:30 pm Central Time, Monday - Friday

| Part #   |         |         | Part Name                        | Quantity |
|----------|---------|---------|----------------------------------|----------|
| D4015SSC | D4015BC | D4015RC |                                  |          |
| 1        | 35      | 67      | Smoker Door                      | 1        |
| 2        | 2       | 2       | Smoker Body                      | 1        |
| 3        | 3       | 62      | Door Handle                      | 1        |
| 4        | 69      | 69      | Door Latch                       | 1        |
| 5        | 5       | 5       | Controller                       | 1        |
| 6        | 36      | 68      | Control Panel                    | 1        |
| 7        | 37      | 65      | Wood Chip Tray Assembly          | 1        |
| 8        | 8       | 8       | Wood Chip Tray Lid               | 1        |
| 9        | 38      | 64      | Grease Tray                      | 1        |
| 10       | 10      | 10      | Rear Handle                      | 1        |
| 11       | 11      | 11      | Rear Vent                        | 1        |
| 12       | 12      | 12      | Rear Vent Knob                   | 1        |
| 13       | 13      | 13      | Wheel Assembly                   | 2        |
| 14       | 14      | 14      | /                                | -        |
| 15       | 15      | 15      | Cooking Rack Support             | 8        |
| 16       | 16      | 16      | Cooking Rack                     | 4        |
| 17       | 27      | 27      | Water Pan                        | 1        |
| 18       | 18      | 18      | Wood Chip Tray Cover             | 1        |
| 19       | 19      | 19      | Reflector Plate Rail             | 2        |
| 20       | 20      | 20      | Meat Probe                       | 1        |
| 21       | 21      | 21      | Heating Element - Smoke          | 1        |
| 22       | 22      | 22      | Heating Element - Main           | 1        |
| 23       | 23      | 23      | Wood Chip Tray Track             | 2        |
| 24       | 24      | 24      | Power Circuit Board              | 1        |
| 25       | 25      | 25      | Bottom Panel                     | 1        |
| 26       | 26      | 26      | Rear Panel                       | 1        |
| 27       | 27      | 27      | LED Light                        | 1        |
| 28       | 28      | 28      | Lens - LED Light                 | 1        |
| 29       | 29      | 29      | Water Pan - Door                 | 1        |
| 30       | 30      | 30      | Water Pan - Spout                | 1        |
| 31       | 39      | 66      | Wood Chip Tray Lower Panel       | 1        |
| 32       | 40      | 63      | /                                | 1        |
| 33       | 33      | 33      | High Temp Limiter                | 1        |
| 34       | 34      | 34      | /                                | -        |
| 41       | 41      | 41      | Cabinet Back Panel               | 1        |
| 42       | 42      | 42      | Cabinet Right Panel              | 1        |
| 43       | 43      | 43      | Cabinet Bottom Panel Assembly    | 1        |
| 44       | 50      | 70      | Cabinet Right Door               | 1        |
| 45       | 45      | 45      | Cabinet Top Cross Brace Assembly | 1        |
| 46       | 46      | 46      | Cabinet Left Panel               | 1        |
| 47       | 51      | 71      | Cabinet Left Door                | 1        |
| 48       | 52      | 48      | Cabinet Door Handle              | 2        |
| 49       | 53      | 72      | Grease Tray                      | 1        |
| 54       | 54      | 54      | Hardware Pack                    | 1        |

# Smoker Assembly

## Step 1

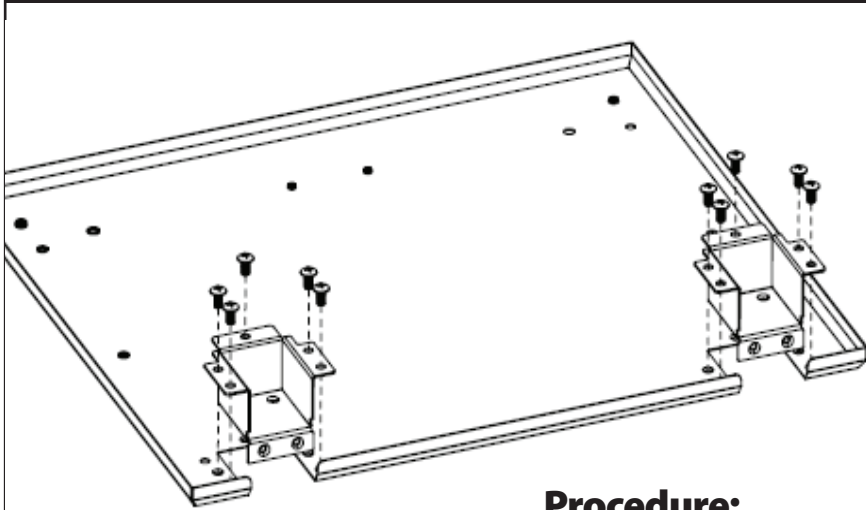

### Locate:

- (1) Cabinet Bottom Panel Assembly
- (2) Wheel Mounting Brackets
- (10) M6 x 20 bolts

### Tools Needed:

Phillips Screwdriver

### Procedure:

Use (10) M6 x 20 bolts to assemble the (2) Wheel Mounting Brackets to the Cabinet Bottom Panel as shown.

## Step 2

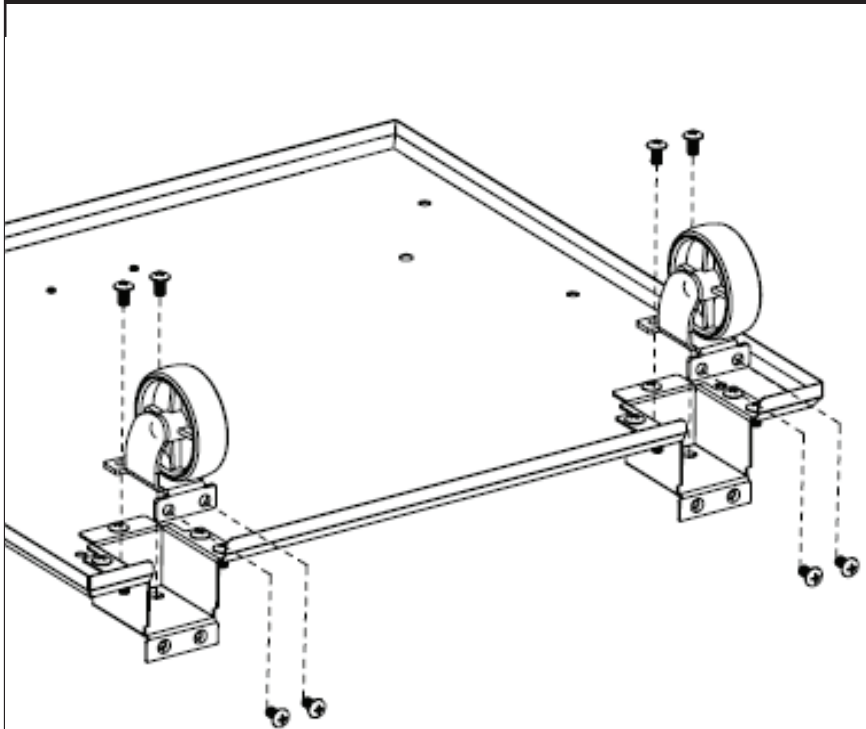

### Locate:

- (1) Cabinet Bottom Panel Assembly
- (2) Wheel Assembly
- (8) M6 x 20 bolts

### Tools Needed:

Phillips Screwdriver

### Procedure:

Use (8) M6 x 20 bolts to assemble the (2) Wheel Assembly to the Cabinet Bottom Panel Assembly as shown.

# Smoker Assembly

## Step 3

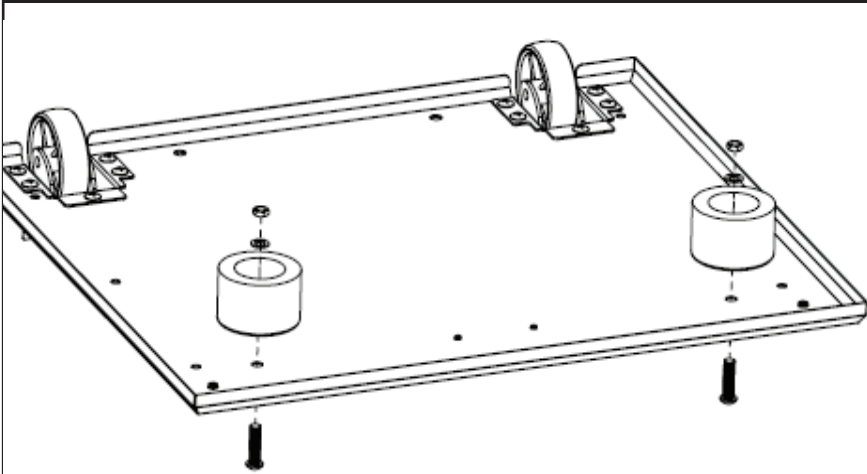

### Locate:

- (1) Cabinet Bottom Panel Assembly
- (2) Front Pads
- (2) M8 x 30 bolts
- (2) M8 Washers
- (2) M8 Nuts

### Tools Needed:

Phillips Screwdriver

### Procedure:

Use (2) M8 x 30 bolts, (2) M8 Washers and (2) M8 Nuts to assemble the (2) Front Pads to the Cabinet Bottom Panel as shown.

## Step 4

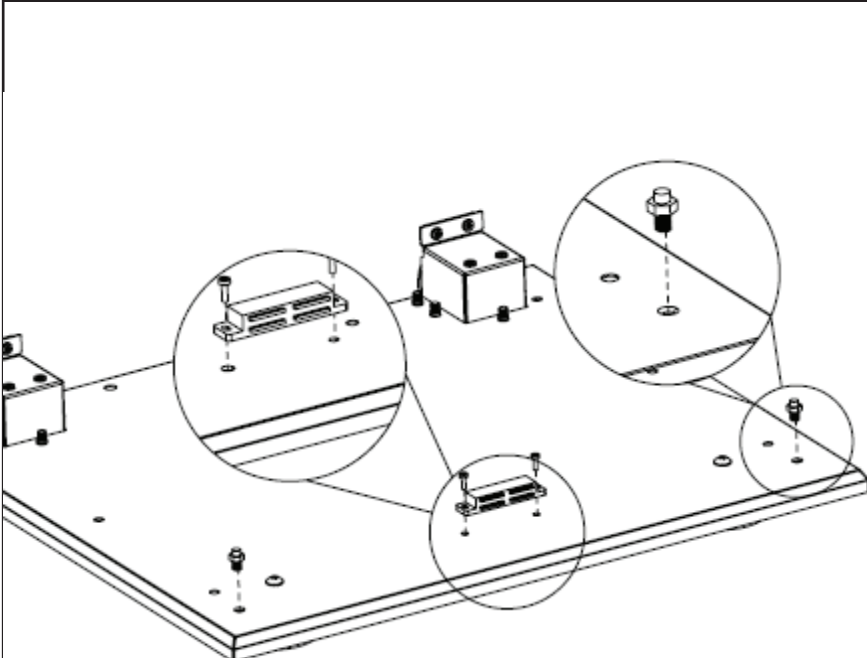

### Locate:

- (1) Cabinet Bottom Panel Assembly
- (2) M3 x 10 bolts
- (1) Cabinet Door Magnet
- (2) Cabinet Door Pivots

### Tools Needed:

Phillips Screwdriver

### Procedure:

Use (2) M3 x 10 bolts to assemble the (1) Cabinet Door Magnet and assemble the (2) Cabinet Door Pivots to the Cabinet Bottom Panel Assembly as shown.

# Smoker Assembly

## Step 5

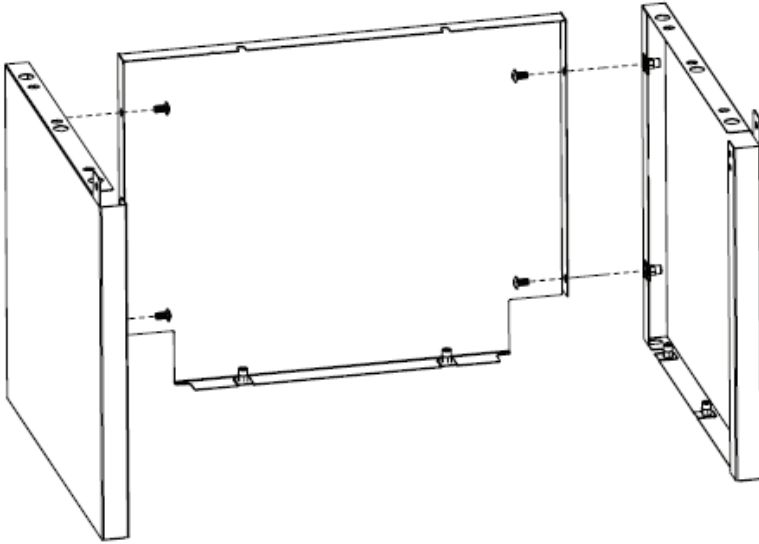

### Locate:

- Cabinet Left Panel
- Cabinet Back Panel
- Cabinet Right Panel
- (4) M6 x 20 bolts

### Tools Needed:

Phillips Screwdriver

### Procedure:

Use (4) M6 x 20 bolts to assemble the Cabinet Left Panel, Cabinet Back Panel and Cabinet Right Panel as shown.

## Step 6

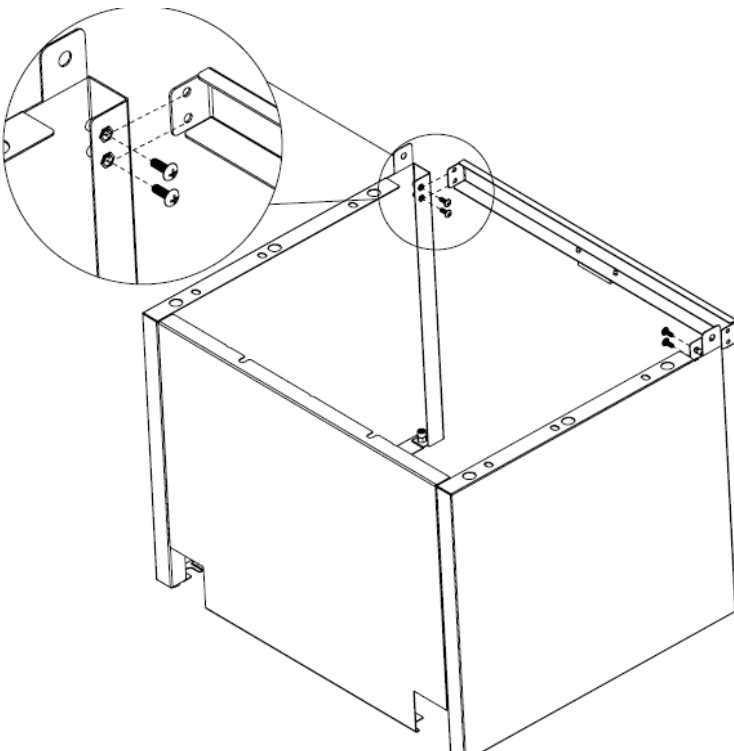

### Locate:

- Cabinet Panel Assembly
- Cabinet Top Cross Brace Assembly
- (4) M4 x 12 bolts

### Tools Needed:

Phillips Screwdriver

### Procedure:

Use (4) M4 x 12 bolts to assemble the Cabinet Top Cross Brace Assembly as shown.

# Smoker Assembly

## Step 7

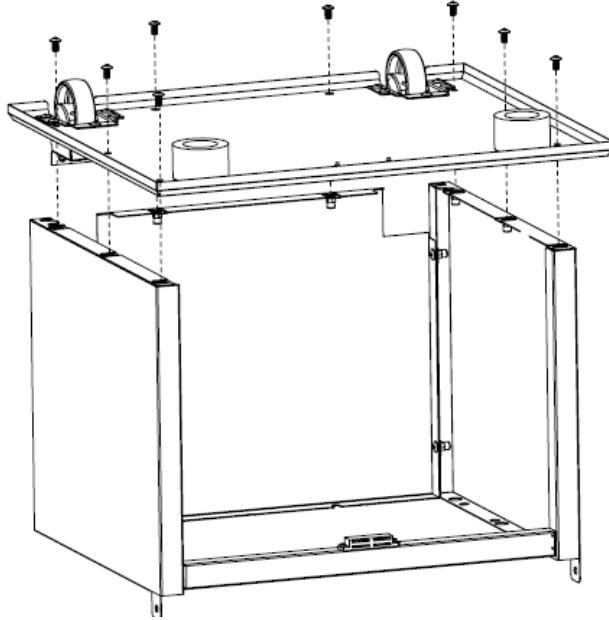

### Locate:

- Cabinet Left Panel
- Cabinet Back Panel
- Cabinet Right Panel
- (4) M6 x 20 bolts

### Tools Needed:

Phillips Screwdriver

### Procedure:

Use (4) M6 x 20 bolts to assemble the Cabinet Left Panel, Cabinet Back Panel and Cabinet Right Panel as shown.

## Step 8

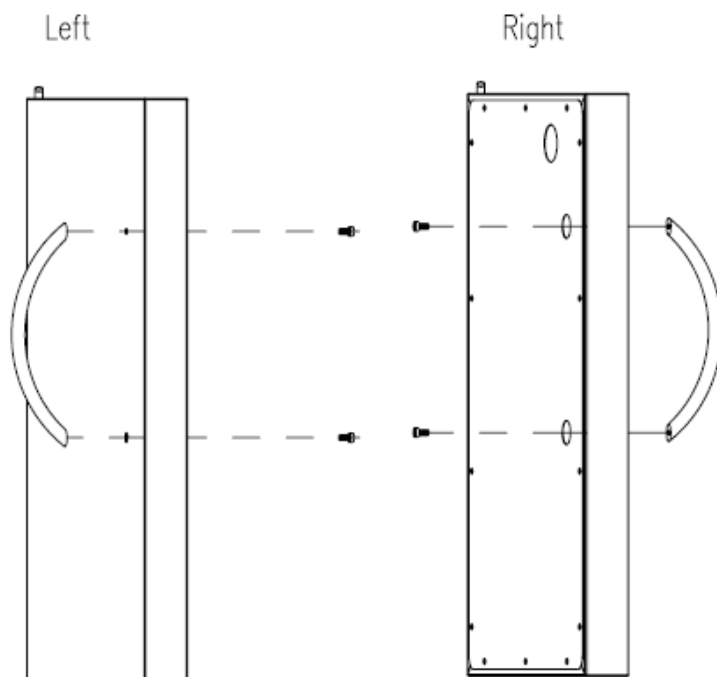

### Locate:

- Cabinet Left Door
- Cabinet Right Door
- (2) Cabinet Door Handle
- (4) M4 x 8 bolts

### Tools Needed:

Phillips Screwdriver

### Procedure:

Use (4) M4 x 8 bolts to assemble the (2) Cabinet door Handles to the Cabinet Left Door and right Door as shown.

# Smoker Assembly

## Step 9

### Procedure:

Turn the Smoker Cabinet upside down. Use (10) M6 x 20 bolts to assemble the Cabinet Assembly to the bottom of the smoker body as shown. Return Smoker Body to upright position.

### Locate:

- Cabinet Assembly
- (10) M6 x 20 bolts

### Tools Needed:

Phillips Screwdriver

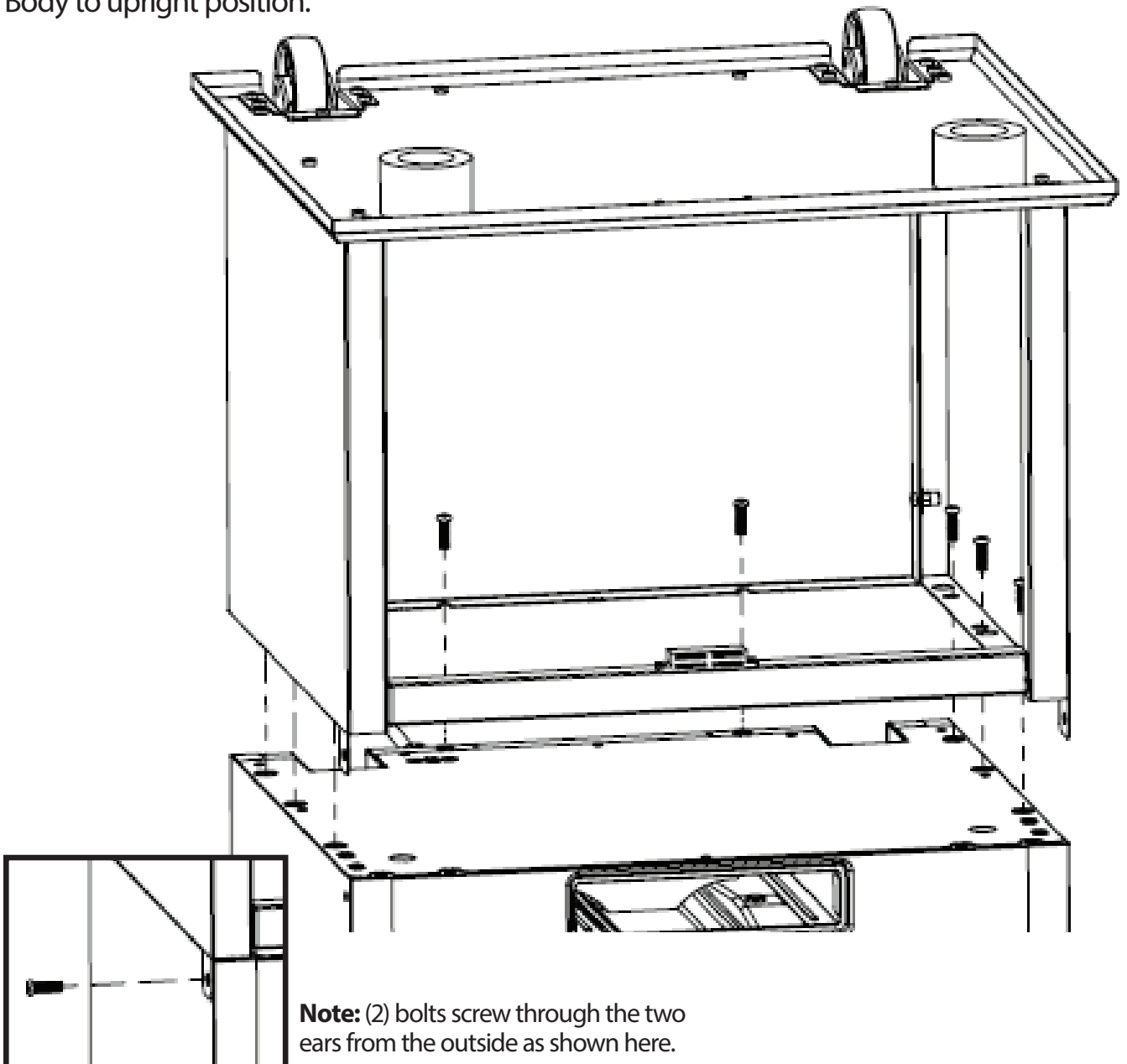

**Note:** (2) bolts screw through the two ears from the outside as shown here.

# Smoker Assembly

## Step 10

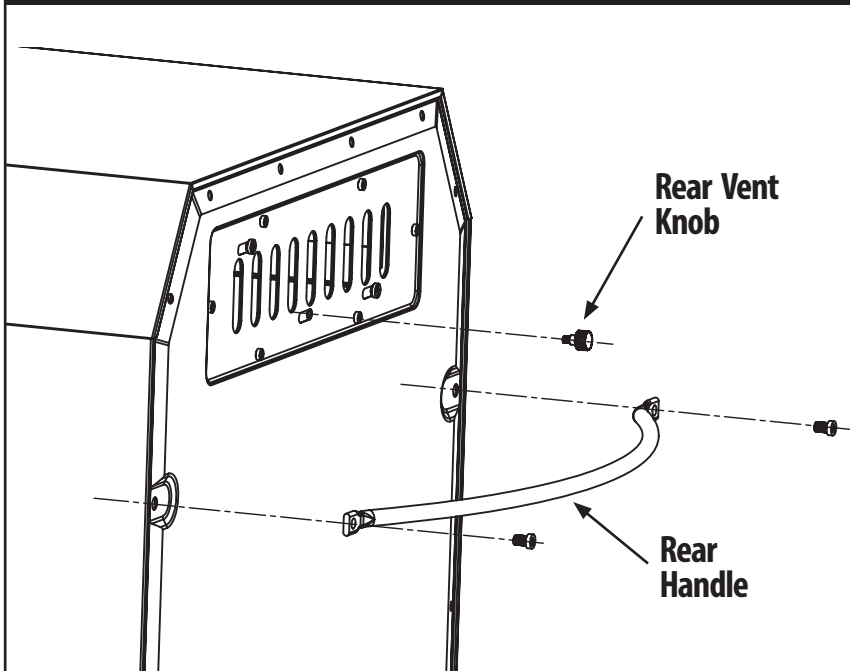

### Locate:

- Rear Handle
- Rear Vent Knob
- (2) M6 x 20 bolts

### Tools Needed:

Phillips Screwdriver

### Procedure:

Use (2) M6 x 20 bolts to assemble the Rear Handle to the smoker cabinet. Screw the Vent Knob to the Rear Vent as shown.

*Note: Hand tighten knob.*

## Step 11

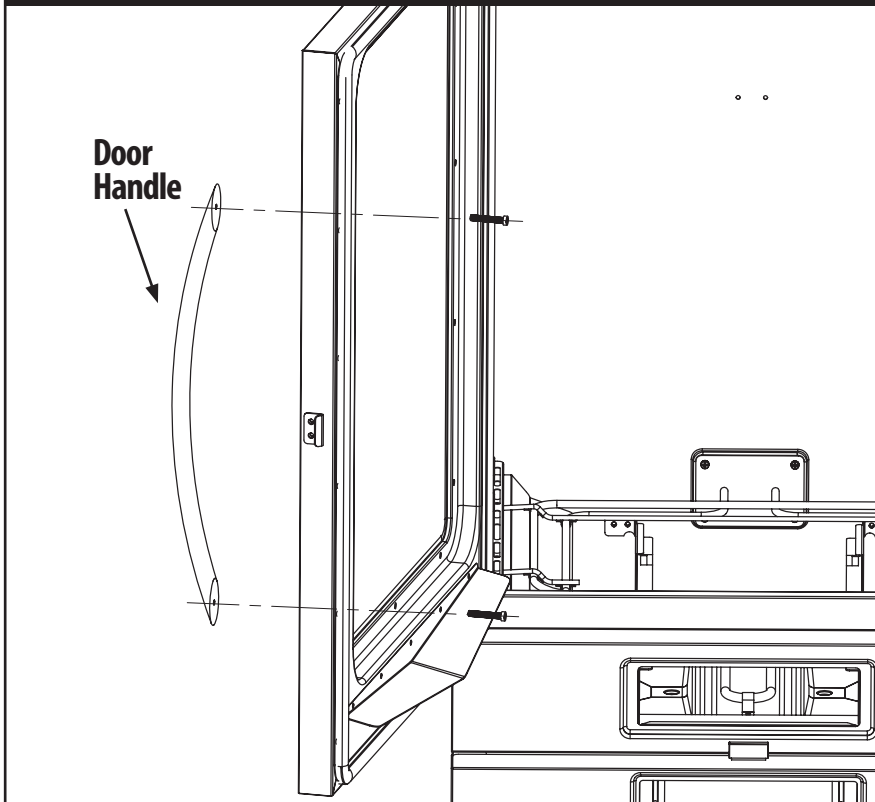

### Locate:

- Door Handle
- (2) M5 x 40 bolts

### Tools Needed:

Phillips Screwdriver

### Procedure:

Use (2) M5 x 40 bolts to assemble the Door Handle as shown.

# Smoker Assembly

## Step 12

### Locate:

- Wood Chip Tray Cover
- Water Pan

### Tools Needed:

None

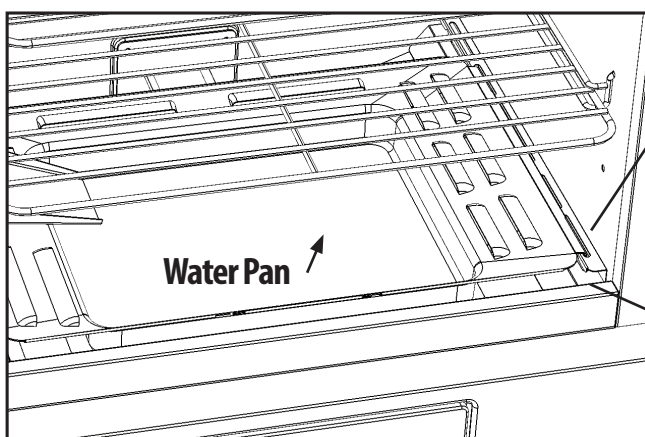
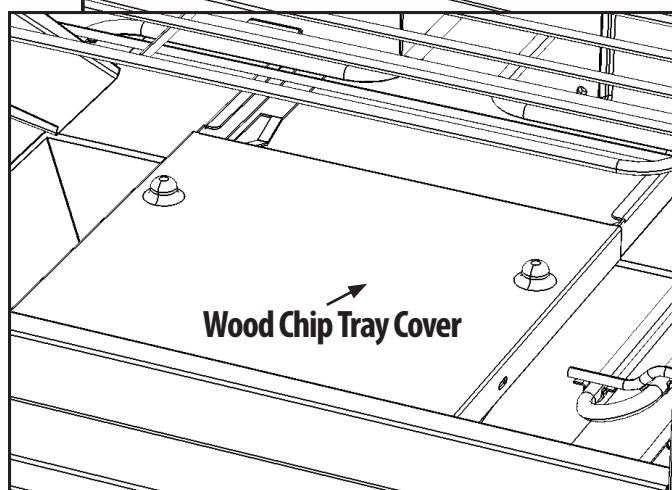
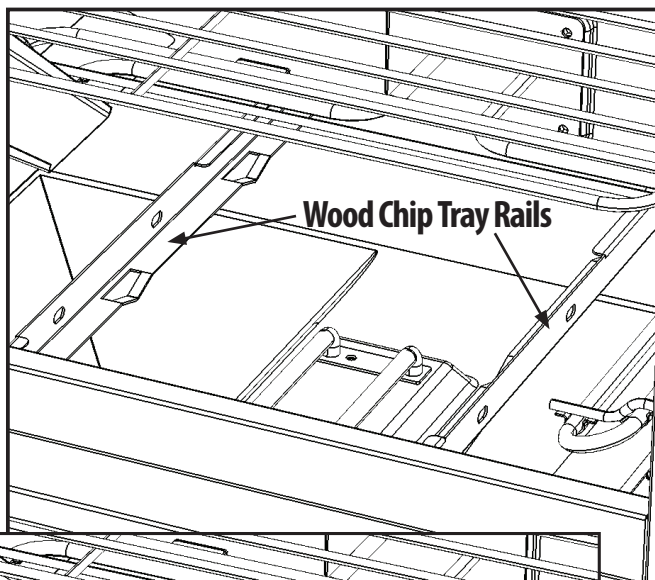

### Procedure:

Position the wood chip tray cover over the (2) wood chip tray rails inside the smoker. The dimples on the side of the wood chip tray cover should sit into the recesses in the wood chip tray rails.

Position the water pan onto the reflector plate rails on the sides of the smoker as shown. The tabs on the sides of the water pan will fit into the slots in the reflector rails as shown.

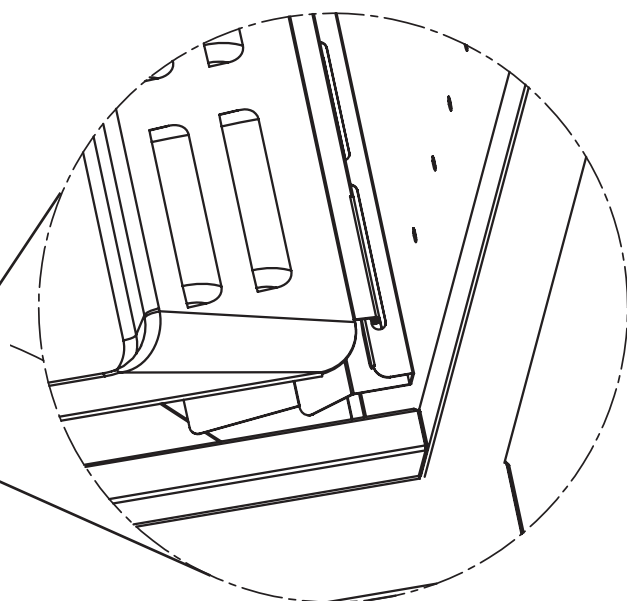

# Smoker Assembly

## Step 13

### Locate:

- Water Pan-Spout
- (8) Rack Supports

### Tools Needed:

None

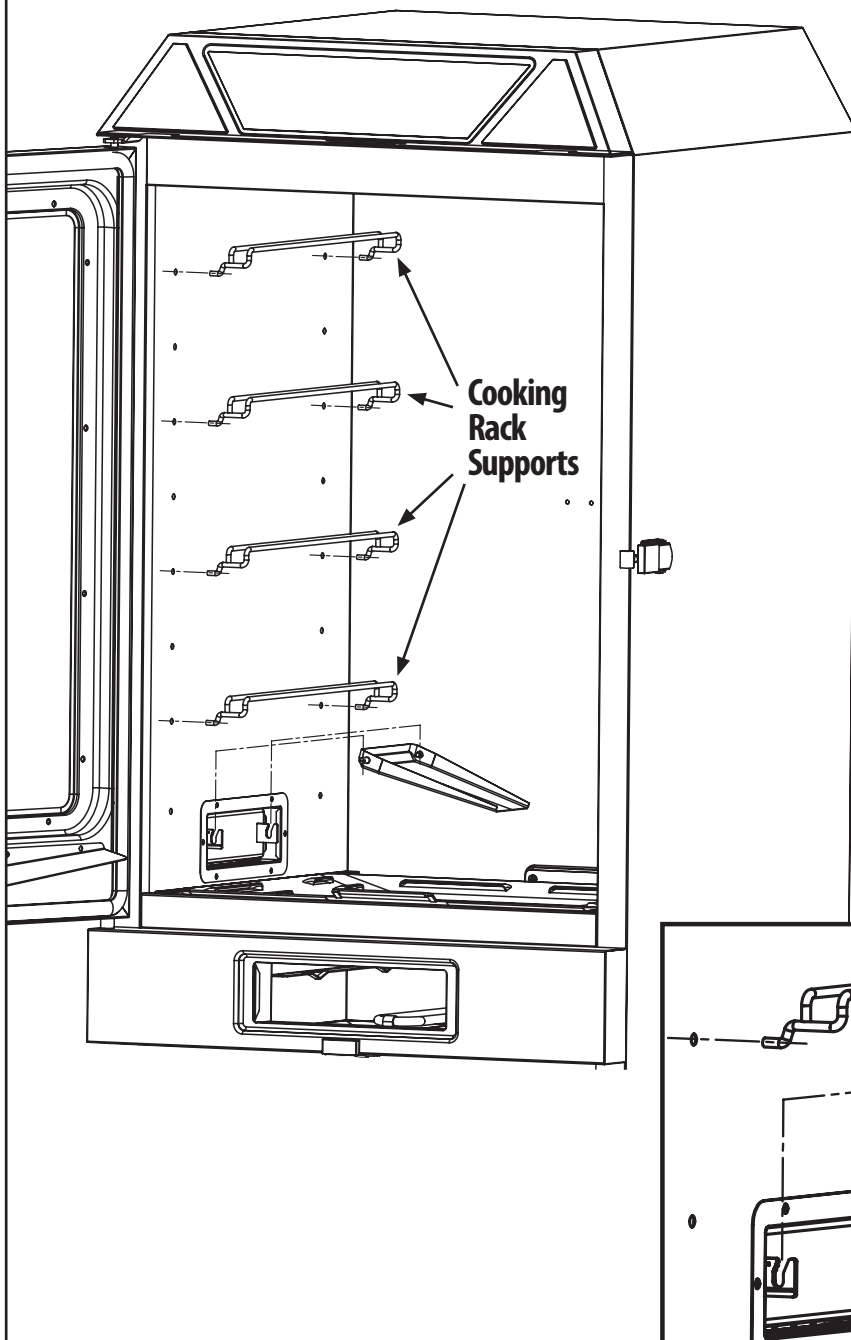

### Procedure:

Assemble (4) rack supports in the holes in the left side of the smoker. Repeat the procedure for the right side making sure the rack supports on the left side and right side are at the same height so the cooking racks are level.

Assemble the water pan-spout to the water pan-door as shown below.

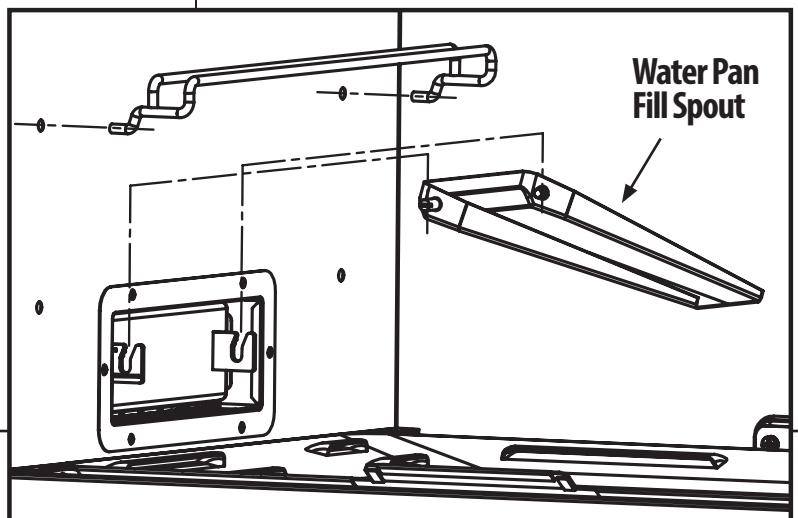

# Smoker Assembly

## Step 14

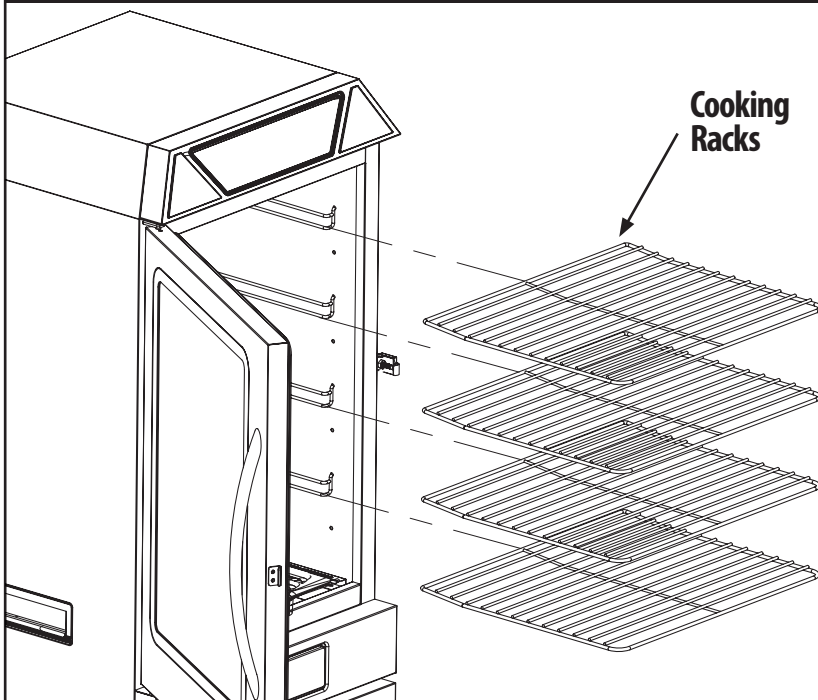

### Locate:

- (4) Cooking Racks

### Tools Needed:

None

### Procedure:

Place the (4) cooking racks into the cooking rack supports as shown. Make sure the angled portion of the rack is slid in first.

## Step 15

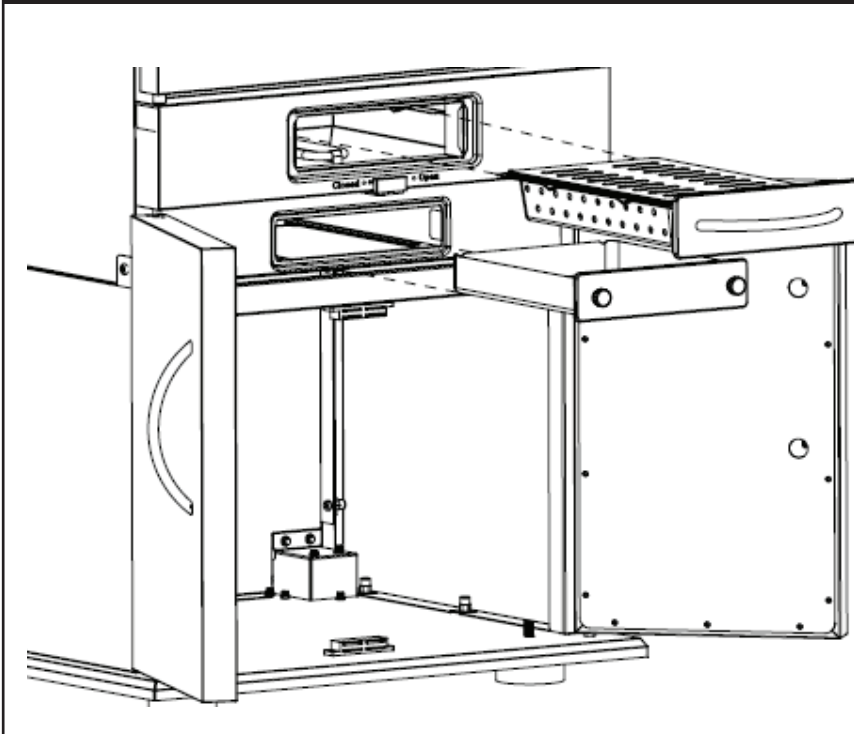

### Locate:

- Wood Chip Tray Assembly
- Grease Tray

### Tools Needed:

None

### Procedure:

Slide the wood chip tray assembly and grease tray into the rails in smoker body as shown.

# Smoker Assembly

---

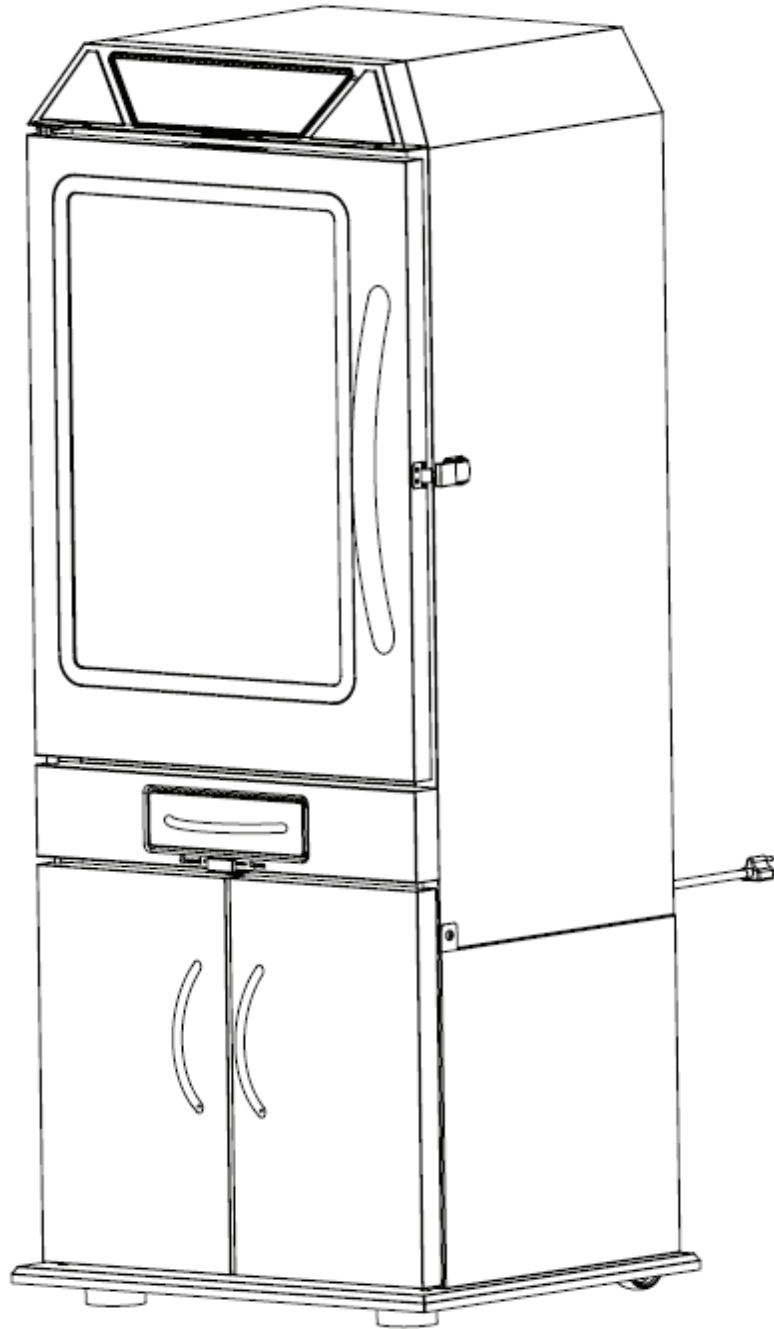

**ASSEMBLY OF YOUR SMOKER IS NOW COMPLETE.  
FOR YOUR SAFETY, FOLLOW ALL SAFE GUARDS  
AND INSTRUCTIONS.**

# Seasoning Instructions

SEASON YOUR SMOKER PRIOR TO ITS FIRST USE.  
A BURNT GREASE SMELL MAY OCCUR DURING THIS TIME. THIS IS  
NORMAL DURING THE SEASONING PROCESS.

1. Make sure water pan is in place without water.
2. Set the temperature to 275°F, set the time for 3 hours and turn the smoker on.
3. To complete the seasoning process, add wood chips to the wood chip tray for the last 45 minutes.

**Caution: Never overfill the wood chip tray. Make sure the wood chip tray cover is completely closed.**

4. Turn off the unit and allow to cool down.

## How to Use Wood Chip Tray

1. Before starting the unit, fill the wood chip tray with wood chips.

**Caution: Never overfill the wood chip tray. Make sure the wood chip tray lid closes completely on the wood chip tray.**

2. Never use wood chunks or wood pellets in the wood chip tray.
3. Insert the wood chip tray into place.
4. Check the wood chip tray periodically to see if the wood chips have burned down by sliding the wood chip tray out about half way and look through the slots in the wood chip tray cover.
5. If the wood chips have completely burned in the wood chip tray, remove the tray from the smoker.

**Caution: The wood chip tray and lid will be HOT, even if the handle is not.**

6. Dump the burned wood chips from the wood chip tray into a metal pan with water. The wood chip tray lid will stay attached to the wood chip tray during this process.
7. Repeat step 1.

**Caution: Never overfill the wood chip tray. Make sure the wood chip tray lid closes completely on the wood chip tray.**

### CAUTION:

Always keep smoker door closed  
when removing or adding wood chips.

### CAUTION

A FLARE UP MAY OCCUR WHEN YOU PULL OUT THE WOOD CHIP TRAY. IMMEDIATELY PUSH TRAY BACK IN AND WAIT FOR WOOD CHIPS TO BURN DOWN BEFORE OPENING THE DOOR AGAIN. DO NOT SPRAY WITH WATER.

# Important Facts for Using Smoker

- Maximum temperature setting is 290°F (143°C).
- Do NOT move unit across uneven surfaces.
- Rear handle is NOT for lifting.
- Wood chip tray lid MUST be in place when using smoker. This minimizes the chance of wood flare ups.
- Wood chips must be used in order to produce smoke and create the smoke flavor.
- Check grease tray often during cooking. Empty grease tray before it gets full. Grease tray may need to be emptied periodically during cooking.
- Do not open smoker door unless necessary. Opening smoker door causes heat to escape and may cause wood to flare up. Closing the door will re-stabilize the temperature and stop flare up.
- If a flare up occurs in your wood chip tray, leave the door closed and close the lower air intake vent until flare up stops. If the flare up continues for 10 or more minutes, shut the smoker off to allow the flare up to stop.
- Do not leave old wood ashes in the wood chip tray. Once ashes are cold, empty tray. Tray should be cleaned out prior to, and after each use to prevent ash buildup.
- Glass in door is tempered and will not break under normal operation.
- This is a smoker. There will be a lot of smoke produced when using wood chips. Some smoke may escape through seams and turn the inside of smoker black. This is normal. To minimize smoke loss around door, the door latch can be adjusted to further tighten door seal against body.
- Opening smoker door during cooking process may extend cooking time due to heat loss.
- When outside temperature is cooler than 65°F (18°C) and/or altitude is above 3,500 feet (1067m), additional cooking time may be required. To ensure that meat is completely cooked use a meat thermometer to test internal temperature.
- To adjust door latch, loosen hex nut on door latch. Turn hook clockwise to tighten. Secure hex nut firmly against door latch.

## How to Clean Smoker

- For the rack tracks, cooking racks, water pan and grease drip pan, use a mild dish detergent. Rinse and dry thoroughly.
- For the wood chip tray, clean frequently to remove ash build up, residue and dust.
- Dispose of cold ashes by placing them in aluminum foil, soaking with water and discarding in a non-combustible container.
- For the interior (glass in door and meat probe) and exterior of the smoker, simply wipe down with a damp cloth. Do not use a cleaning agent. Make sure to dry thoroughly.
- Door seal and inside seam that seal attaches to MUST be cleaned with a damp cloth after each use to keep seal in proper working condition.

### **▲ WARNING ▲**

**ALWAYS MAKE SURE UNIT IS UNPLUGGED AND COOL TO THE TOUCH BEFORE CLEANING AND STORING.**

# Operating Instructions

## Control Panel Operations

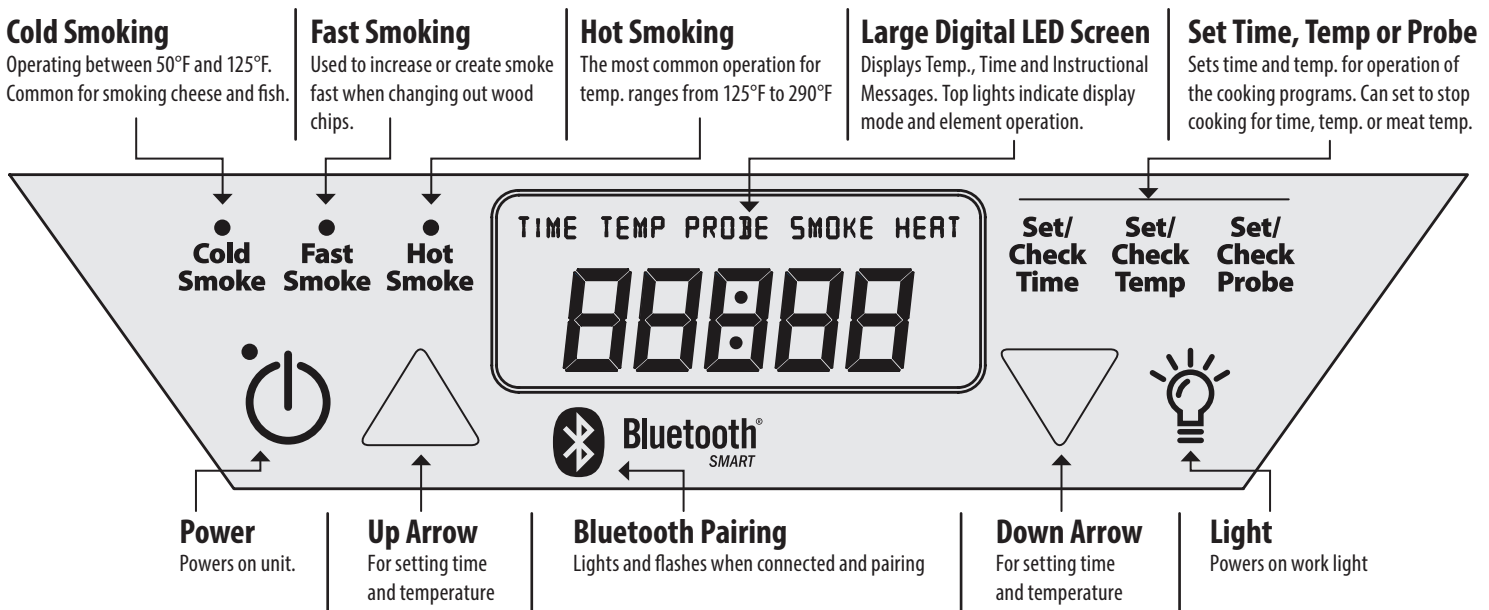

## Control Panel Functions



The **POWER** button powers the unit on. When the power cord is plugged in, the blue LED light will flash indicating the unit has power. When the POWER button is pushed the unit will turn on and the light will stay on.



The **BLUETOOTH PAIRING** button has a blue LED indicator light that will flash during the pairing operation and will remain solid lit when paired. (The Bluetooth will pair when the unit is plugged in). If for any reason the unit does not go into pair mode the Bluetooth button can be pushed to place the unit into pairing mode.



When the **COLD SMOKE** button is pressed, the LED light will flash during the program set up. When the program is in operation, the LED light will be on solid. The COLD SMOKE button allows you to operate between the temperatures of 50°F and 125°F. You are able to set your smoking time, smoking temperature and probe temperature after the COLD SMOKE button is pushed. Outside temperatures may affect your ability to cold smoke. If your internal temperature in your smoker is higher than 125°F, the LED screen will inform you that your unit is too hot by displaying "2-hot".



When the **FAST SMOKE** button is pressed the LED will light solid while the program is in operation. The FAST SMOKE button serves (2) functions. The first is to get the wood chips smoking faster when you are in either of the smoking programs. The second is to get the wood chip drawer with new wood chips started faster after dumping burned up wood chips. The FAST SMOKE can be used anytime after the initial 20 minutes during the smoking functions. The FAST SMOKE mode will be on for 20 minutes. You will see the LED display show the 20 minutes counting down to zero. Your current smoking program is still running in the background during the 20 minutes the FAST SMOKE is in use. After the 20 minutes the smoking program will resume. You can stop the FAST SMOKE at any time during the running of the program by pressing the FAST SMOKE button again.



When the **HOT SMOKE** button is pressed, the LED light will flash during the program set up. When the program is in operation the LED light will be on solid. The HOT SMOKE button allows you to operate between the temperatures of 125°F and 290°F. You are able to set your smoking time, smoking temperature and probe temperature after the HOT SMOKE button is pushed. Outside temperatures may affect your internal temperatures during the hot smoke program.

**CAUTION:** If the smoker's internal temperature reaches higher than 302°F, the smoker will automatically shut off until the temperature is below 290°F.

# Operating Instructions

## Set/ Check Time

The **SET/CHECK TIME** button allows you to set your smoking time from 1 hour to 99 hours. You are also able to check the time left to smoke during any smoke program by pressing the SET/CHECK TIME button once. Your time will change in 1 hour increments with pressing the SET/CHECK TIME button one time. After you have set your hours, if you press the SET/CHECK TIME button again you will be able to set the minutes for your smoking cycle. Your minutes will change in 10 minute increments.

## Set/ Check Temp

The **SET/CHECK TEMP** button allows you to set your desired smoking temperature in the smoking programs. You will be able to set your temperature range in the Cold Smoking program between 50°F and 125°F and in the Hot Smoking program between 125°F and 290°F. You are able to check your internal temperature inside the smoker at any time during any of the smoking programs by pressing the SET/CHECK TEMP button once. Your temperature will change in 5°F increments when setting the internal smoker temperature.

## Set/ Check Probe

The **SET/CHECK PROBE** button allows you to set your desired meat probe temperature in the smoking programs. You will be able to set your meat probe temperature range in both Smoking programs between 50°F and 300°F. If you chose not to use the meat probe, you can press the SET/CHECK PROBE button and when you reach the lowest temperature the next setting will shut the probe OFF. You are able to check your meat probe temperature at any time during any of the smoking programs by pressing the SET/CHECK PROBE button once. Your temperature will change in 5°F increments when setting the meat probe temperature. Once the meat probe reaches the set temperature, there will be an alert sound for 3 seconds to notify you that the meat probe has reached the set temperature. The probe will not disengage the elements.



The **ARROW CONTROL** buttons allow you to change the time and temperature up and down accordingly. When you press the UP/DOWN ARROW button, the time will change in 1 hour increments or 10 minute increments and the temperature will change in 5°F increments. If you push and hold the UP/DOWN ARROW button for 3 seconds or more, the time and temperature will scroll at a faster rate.



When the **LIGHT** button is pressed the LED light under the control panel will power on. When the button is pressed a second time the LED light will power off. The LED light will be operational during any status, including the stand by status.

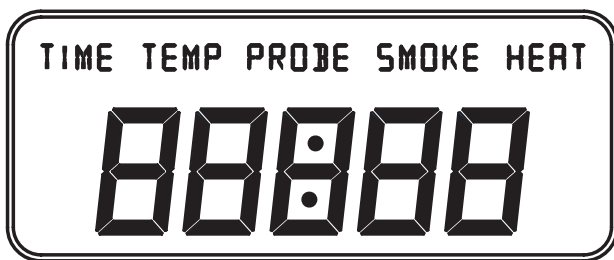

The **DIGITAL LED SCREEN** is your information center for the smoker. The LED screen will display your Time, Temperature and Meat Probe Temperatures you have set. When you have chosen a smoking mode and set your information, the LED screen will scroll between Time, Temperature and Meat Probe Temperature during the smoking cycle.

There are 5 displays above the LED screen, Time, Temp, Probe, Smoke and Heat. When these modes are operational, the individual display will be lit to indicate they are operating.

1. The **"TIME"** will be lit on the controller when you are setting the time in the program modes and when the LED screen is scrolling and the remaining time appears on the screen.
2. The **"TEMP"** will be lit on the controller when you are setting the temperature in the program modes and when the LED screen is scrolling and the temperature appears on the screen.
3. The **"PROBE"** will be lit on the controller when you are setting the meat probe temperature in the program modes and when the LED screen is scrolling and the meat probe temperature appears on the screen.
4. The **"SMOKE"** will be lit on the controller when the smoke element is turned on during the program modes and when the **"FAST SMOKE"** is on.
5. The **"HEAT"** will be lit on the controller when the heat element is turned on during the program modes.

# Operating Instructions

1. Plug the power cord into a GFI Outlet. The blue indicator light on the POWER button will flash indicating there is power to the smoker.
2. Push the POWER button to turn the smoker ON. There will be an alert sound for 3 seconds and the LED screen will light up indicating the smoker is ready to use. The LED screen will then scroll between "TIME", "TEMP" (Internal Smoker Temperature) and "PROBE" (Meat Probe Temperature)
3. Open side water fill door and fill water pan half full with water. (During your smoking process, you can add additional water through the side water fill door. - Note: Do not overfill.)
4. Fill the wood chip tray with wood chips. Refer to the section "How to use the wood chip tray" on page 13
5. Press either the "HOT SMOKE" or "COLD SMOKE" button to set your smoking program preference.
6. Press the "SET/CHECK TIME" button to set the smoking cycle time.
  - Press the button once to set hours.
  - Press the UP or DOWN arrow to increase or decrease the hours.
  - Press the button again to set minutes.
  - Press the UP or DOWN arrow to increase or decrease the minutes.
7. Press the "SET/CHECK TEMP" button to set the time and to set the desired temperature inside the smoker.
  - Press the UP or DOWN arrow to increase or decrease temperature.
8. Press the "SET/CHECK PROBE" button to set the smoker temperature and to set the desired meat probe temperature. - Press the UP or DOWN arrow to increase or decrease the desired meat probe temperature.
9. Press the "HOT SMOKE" or "COLD SMOKE" button again to start your smoking program.
10. When you are in a "HOT SMOKE" or "COLD SMOKE" program, your LED screen will scroll between the time left to smoke, the internal temperature of the smoker and the meat probe temperature. When the program time runs out, the smoker will shut off. When the meat reaches the set temperature on the meat probe, there will be an alert sound for 3 seconds indicating that the meat is done. Note: The smoker will still be running and the LED screen will display time, temp and the probe temp.

NOTE: If at any time the consumer presses the Check Time, Temp or Probe button, the display will change to the current time remaining, the current temperature or the current probe temperature. By holding the Set Time or Temp button for 3 seconds during the hot or cold smoke cycle, the LED will flash the current set time or temperature. The time or temperature can be changed by using the up and down arrows as defined above. The change can be confirmed by pressing the set button a second time.

11. Your wood chips should start to smoke in 10 - 15 minutes depending on the type of wood chips. After 20 minutes your wood chips should "Wick" and continue to smoke for the rest of the program cycle. Below is a chart with recommended settings for both of the air intakes (Vents) on the smoker.

| Recommended Air Intake Settings |                  | Smoke Programs                                  |   |
|---------------------------------|------------------|---|---|
|                                 |                  | For <b>HOT</b> Smoke                            | For <b>COLD</b> Smoke                           |
| Back Air Vent                   | First 20 Minutes | Open 100%                                       | Open 100%                                       |
|                                 | Rest of Program  | Open 50%  | Open 100%                                       |
| Bottom Air Vent                 | First 20 Minutes | Open 100%                                       | Open 100%                                       |
|                                 | Rest of Program  | Set to any position for desired amount of smoke | Set to any position for desired amount of smoke |

NOTE: If you feel your wood chips are not producing enough smoke after the initial 20 minutes, press the "FAST SMOKE" button and the smoke element will run for an additional 20 minutes to help get the wood chips smoking. On the LED screen you will see the time counting down from 20 minutes to zero. You can stop the "FAST SMOKE" program at any time by pressing the "FAST SMOKE" button while the program is running.

NOTE: You can set your Air Intake to any opening to achieve your optimal smoke you desire. These are recommended settings to help your chips to last longer and have optimal smoke generated. (Your settings may vary depending on the size of the wood chips used and the density of the wood chips in the wood chip tray.)

NOTE: If your wood chips are producing more smoke than you want, you can slow the smoke being produced by decreasing the lower air intake vent opening to restrict the incoming air.

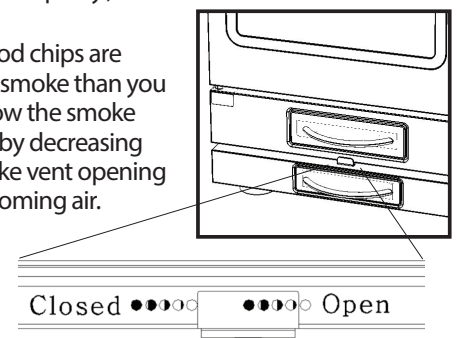

# Troubleshooting Guide

| SYMPTOM   | CAUSE  | SOLUTION   |
|---|--|--|
| No Power to controller (No Beep when plugged into outlet) | Not plugged into outlet                      | Plug into power source   |
|   | House breaker tripped                        | Reset breaker  |
|   | Bad connection at controller                 | Unplug connection and reconnect. Reference how to access/replace controller instructions |
|   | Bad connection at PCB (Power Control Board)  | Unplug connection and reconnect. Reference how to access/replace PCB instructions        |
|   | Faulty PCB (Power Control Board)             | Call OLPI for replacement. Reference how to access/replace PCB instructions              |
|   | Faulty Controller                            | Call OLPI for replacement. Reference how to access/replace controller instructions       |
|   | Faulty body wiring                           | Call OLPI for replacement.   |
| Power light not on (Controller beeps when plugged in)     | Appliance not powered on                     | Press on/off button  |
|   | Faulty controller                            | Call OLPI for replacement. Reference how to access/replace controller instructions       |
| No display on controller (Power light is on)              | Controller temp is below -10°F (-23°C)       | Remove controller from unit and bring to temp above 0°F (-18°C)                          |
|   | Faulty controller                            | Call OLPI for replacement. Reference how to access/replace controller instructions       |
| Heating light not on                                      | Smoking program not set                      | Set Temp and Time in smoking program, wait 60 seconds for heating                        |
|   | Faulty controller                            | Call OLPI for replacement. Reference how to access/replace controller instructions       |
|   | Faulty body wiring                           | Call OLPI for replacement.   |
| Element not on  | Bad connection at HTL                        | Unplug connection and reconnect. Reference how to access/replace HTL instructions        |
|   | Bad connection at the element                | Unplug connection and reconnect. Reference how to access/replace element instructions    |
|   | Faulty HTL (High Temp Limit Safety Shut-off) | Call OLPI for replacement. Reference how to access/replace HTL instructions              |
|   | Faulty element                               | Call OLPI for replacement. Reference how to access/replace element instructions          |
| Meat Probe does not read on controller                    | Bad connection at the meat probe             | Unplug connection and reconnect. Reference how to access/replace meat probe instructions |
|   | Faulty meat probe                            | Call OLPI for replacement. Reference how to access/replace meat probe instructions       |
|   | Faulty controller                            | Call OLPI for replacement. Reference how to access/replace controller instructions       |

# Troubleshooting Guide

| SYMPTOM  | CAUSE   | SOLUTION   |
|--|---|--|
| Cabinet Temp is inaccurate                       | Faulty HTL (High Temp Safety Limit Shut-off)                          | Call OLPI for replacement. Reference how to access/ replace HTL  |
|  | Faulty controller   | Call OLPI for replacement. Reference how to access/replace controller instructions                       |
| Appliance takes excessive amount of time to heat | Climate   | Temps below 65°F (18°C) may extend heating time  |
|  | Appliance plugged into an extension cord                              | Plug appliance directly into power source. Maximum length ext. cord 25ft, min. gauge 12/3                |
|  | Door not closed properly  | Close door and adjust latch so door seals completely   |
|  | Waterbowl/ Drip deflector not properly located                        | Locate waterbowl/drip deflector properly on supports See assembly steps for proper installation          |
|  | Faulty controller   | Call OLPI for replacement. Reference how to access/replace controller instructions                       |
| Gap between the door and smoker                  | Door alignment  | Adjust door hinges   |
|  | Damaged door seal   | Call OLPI for replacement door kit   |
| Grease leaking from smoker                       | Door not closed properly  | Close door and adjust latch so door seals completely around appliance                                    |
|  | Appliance not level   | Move appliance to level surface and adjust height  |
|  | Water pan not in proper location                                      | Align water pan so grease from door goes into water pan  |
|  | Grease tray is full   | Empty grease tray and reinstall under smoker   |
|  | Drain holes are clogged inside smoker                                 | Clean drain holes in smoker bottom   |
| No smoke   | No wood chips   | Add wood chips. (See adding wood chips guide)  |
|  | Smoke element not staying on long enough to heat chips due to climate | Open both the back vent and the lower vent fully. Push the fast smoke button to engage the smoke element |
|  | Damaged smoke tray  | Call OLPI for replacement.   |
| Controller will not adjust time                  | Faulty controller   | Call OLPI for replacement. Reference how to access/replace controller instructions                       |
| Controller will not adjust time                  | Faulty controller   | Call OLPI for replacement. Reference how to access/replace controller instructions                       |
| Error Code: Err                                  | Thermostat probe is damaged/short circuited                           | Call OLPI for replacement  |
|  | Meat probe is damaged/short circuited                                 | Call OLPI for replacement. Reference how to access/replace meat probe instructions                       |
|  | Faulty controller   | Call OLPI for replacement. Reference how to access/replace controller instructions                       |

# Part Replacement Guide

## Heat Element Access/Replacement

### Removal:

1. Make sure smoker is turned OFF and is unplugged from the electrical outlet
2. Remove all cooking racks and water pan from smoker
3. Remove rear handle - (2) screws - (Figure A1)
4. Remove rear vent - (6) screws - (Figure A2)
5. Remove back panel - (17) screws - (Figure A1)
6. Remove wires from Heat Element - (Figure A3)
7. Remove (4) screws from element bracket from inside smoker - (Figure A4)
8. Remove heat element from inside smoker

**Tools Needed:** Phillips Screwdriver

### Installation:

9. Place new heat element into smoker and secure with (4) screws previously removed.
10. Push wires back onto tabs of new heat element from back of smoker
11. Reattach rear panel - (17) screws
12. Reattach rear vent - (6) screws
13. Reattach Rear Handle - (2) screws
14. Place water pan and cooking racks back into smoker.
15. Plug smoker back into an electrical outlet

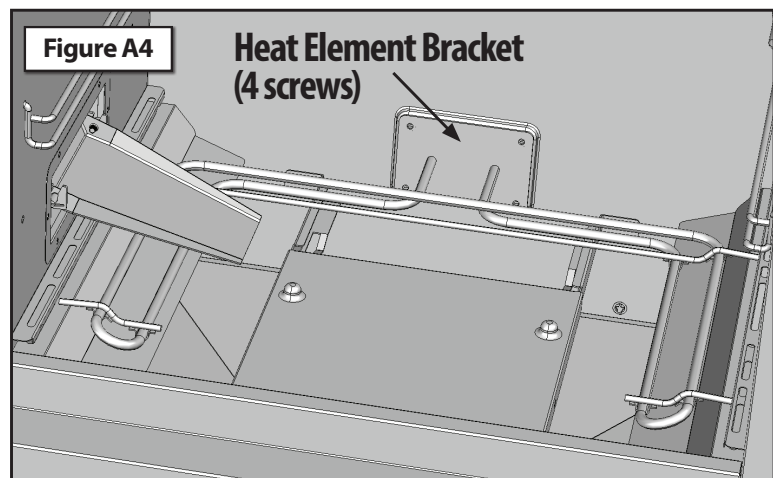
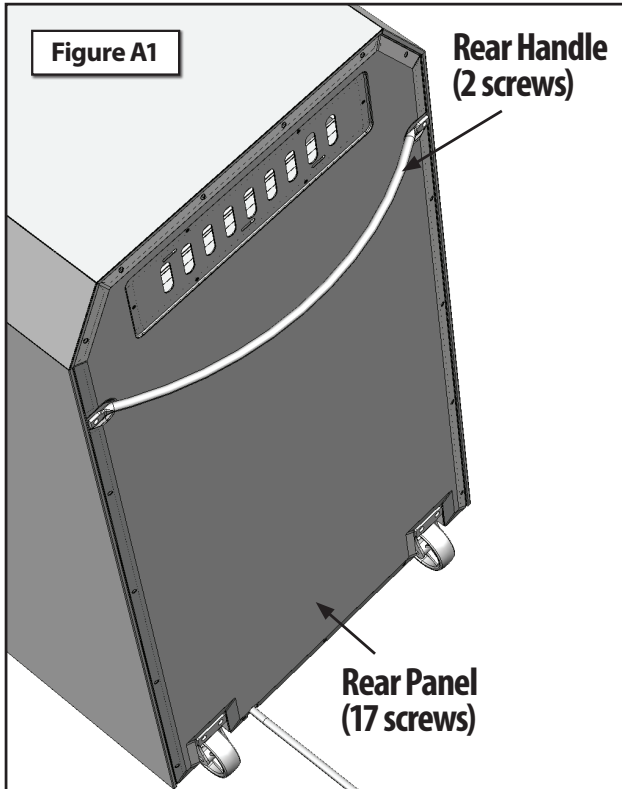
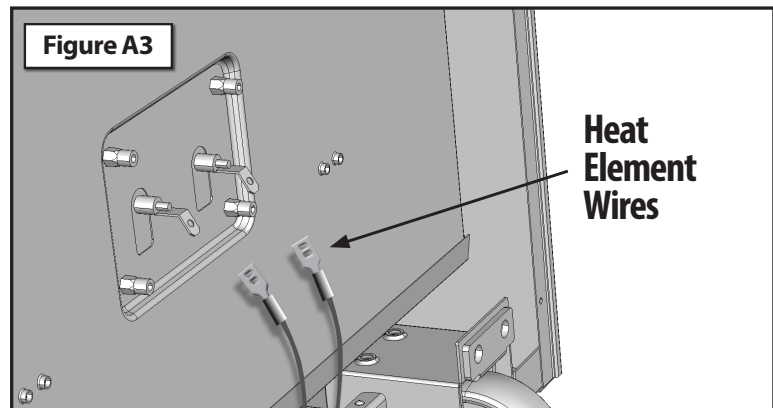
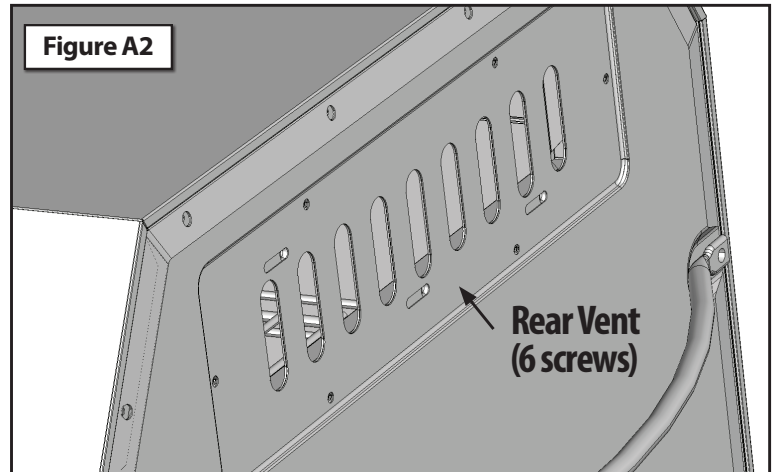

# Part Replacement Guide

## High Temp Limit Safety Switch Access/Replacement

### Removal:

1. Make sure smoker is turned OFF and is unplugged from electrical outlet
2. Remove all cooking racks and water pan from smoker
3. Remove rear handle - (2) screws - (**Figure B1**)
4. Remove rear vent - (6) screws - (**Figure B2**)
5. Remove rear panel - (17) screws - (**Figure B1**)
6. Remove (2) wires that are connected to tabs on High Temp Limit Safety Switch - (**Figure B3**)
7. Remove (2) bolts and nuts from High Temp Limit Safety Switch bracket - (**Figure B3**)

**NOTE:** Will need to secure bolts from inside smoker to remove.

### Installation:

8. Position new High Temp Limit Safety Switch on back of smoker where original switch was in place
9. Using (2) bolts and nuts, secure High Temp Limit Safety Switch to inner back panel
10. Attach wires onto tabs of new High Temp Limit Safety Switch
11. Reattach rear panel - (17) screws
12. Reattach rear vent - (6) screws
13. Reattach rear handle - (2) screws
14. Place water pan and cooking racks back into smoker.
15. Plug smoker back into an electrical outlet

**Tools Needed:** Phillips Screwdriver

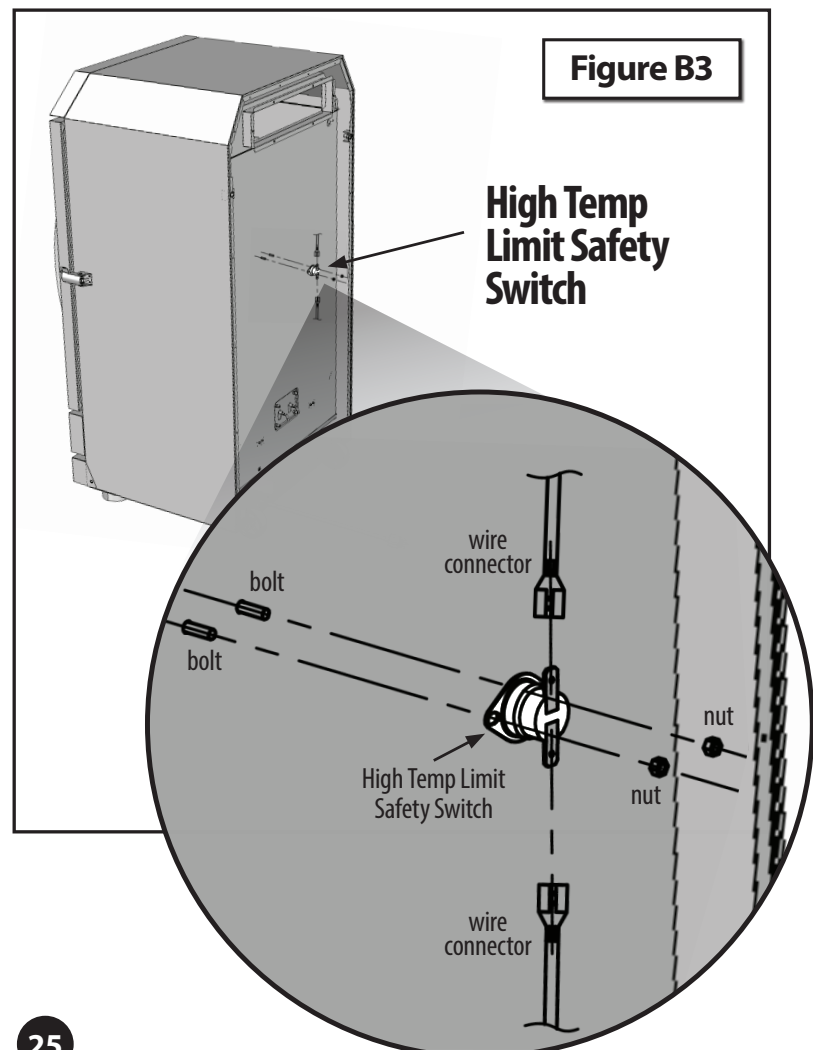
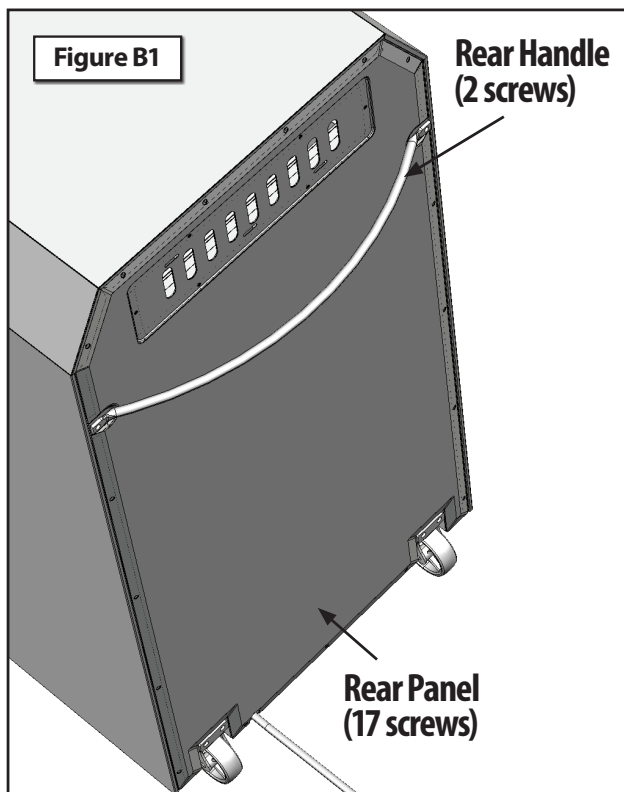
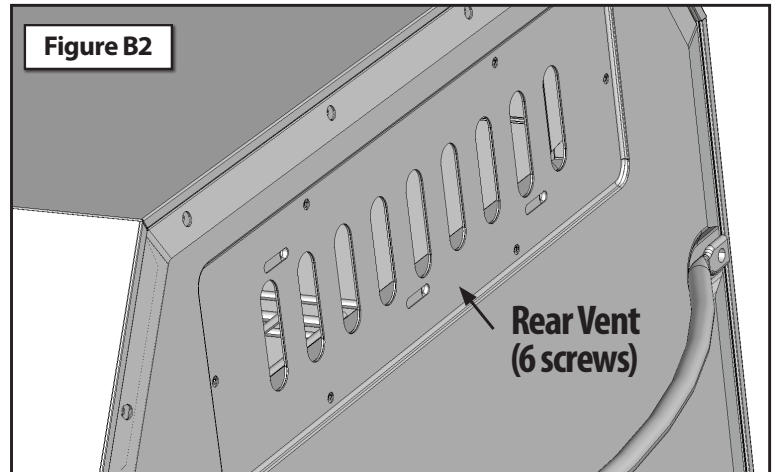

# Part Replacement Guide

## Smoke Element Access/Replacement

### Removal:

1. Make sure your smoker is OFF and is unplugged
2. Remove all cooking racks and water pan from smoker
3. Remove wood chip tray tent, wood chip tray and grease tray
4. Remove (3) screws from smoke element bracket from inside smoker - (Figure C1)
5. Lay the smoker on its side as shown - (Figure C2)
6. Remove bottom panel - (16 screws)
7. Remove wires from Smoke Element - (Figure C3)
8. Remove smoke element from inside smoker

### Installation:

9. Place the new smoke element into smoker and secure with (3) screws previously removed.
10. Push wires back onto the tabs of new smoke element from the back of smoker
11. Reattach bottom panel onto smoker with same 16 screws previously removed
12. Lift smoker back to its upright position
13. Place water pan and cooking racks back into your smoker.
14. Place wood chip tray tent, wood chip tray and grease tray back into smoker
15. Plug smoker back into an electrical outlet

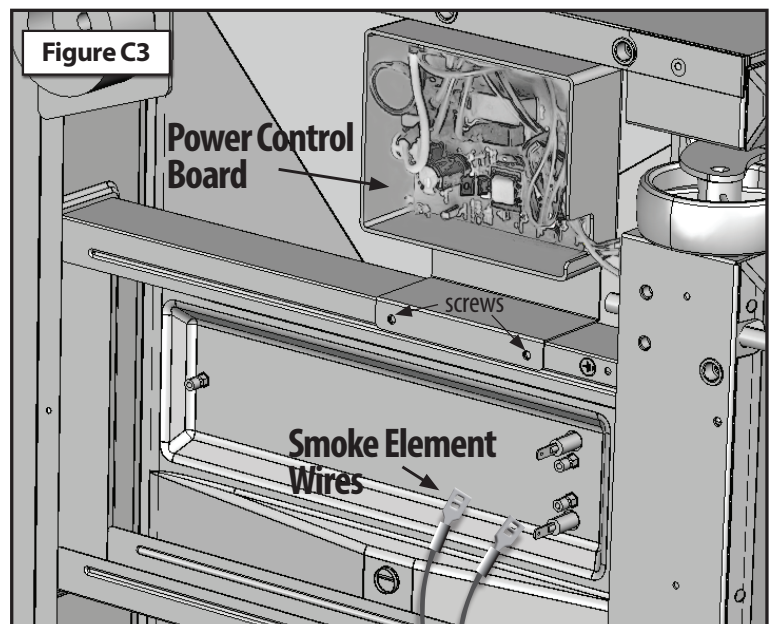
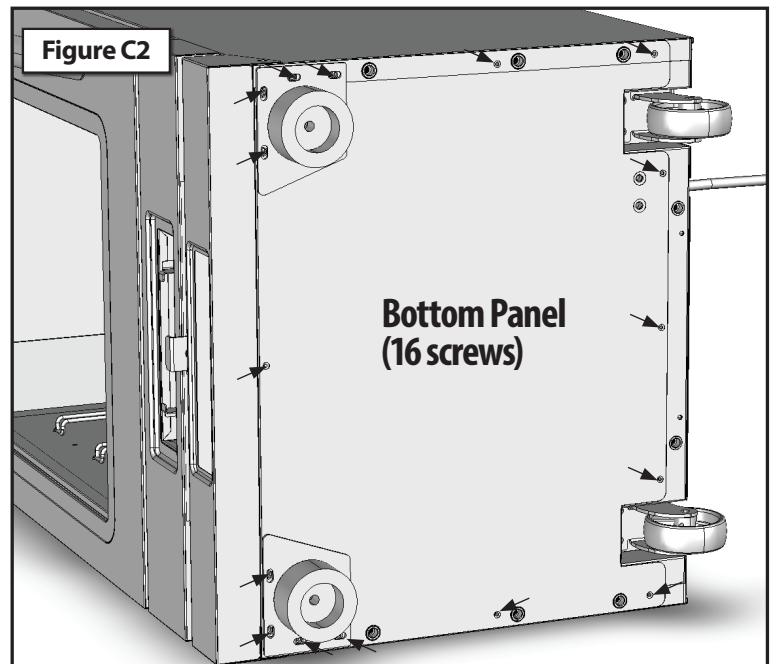
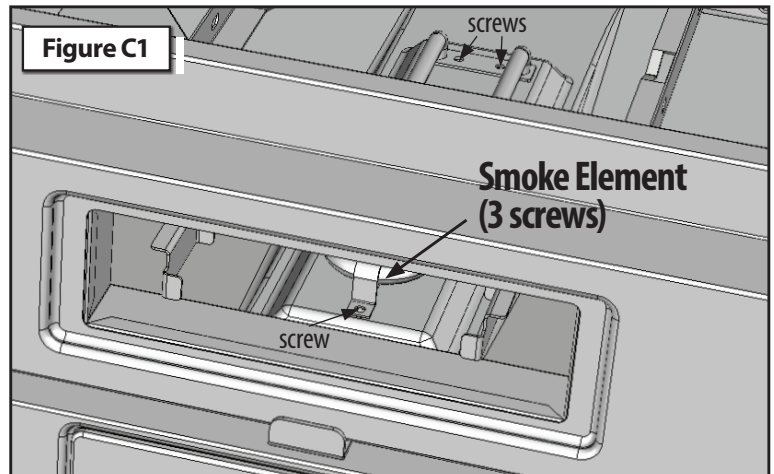

## Power Control Board Access/Replacement

### Removal:

1. Make sure your smoker is OFF and is unplugged
2. Remove all cooking racks and water pan from smoker
3. Remove wood chip tray tent, wood chip tray and grease tray
4. Lay the smoker on its side as shown - (Figure C2)
5. Remove bottom panel - (16 screws)
6. Remove wires from Power Control Board - (Figure C3)
7. Remove Power Control Board - (2 screws) - (Figure C3)

### Installation:

8. Place the new power control board in smoker.
9. Secure new power control board to grease tray rail with same (2) screws previously removed.
10. Connect all wires back onto power control board
11. Assemble bottom panel onto smoker with same 16 screws previously removed
12. Turn smoker back to its upright position
13. Place water pan and cooking racks back into your smoker.
14. Place wood chip tray tent, wood chip tray and grease tray back into smoker
15. Plug smoker back into an electrical outlet

# Part Replacement Guide

## Control Panel/Controller Access/Replacement

### Removal:

1. Make sure your smoker is turned OFF and is unplugged
2. Unlatch and open smoker door.
3. Remove (4) screws from underside of control panel - (Figure D1)
4. Carefully lift control panel up and off of smoker. Be careful not to pull control panel far from smoker as wires are short.
5. Disconnect wires for LED light, Meat Probe, Thermocouple and Power Supply (Note: Make sure to note or label where each connector goes) - (Figure D2)

### Installation:

6. Reconnect wires for LED light, Meat Probe, Thermocouple and Power Supply on new Control Panel and Controller Assembly.
7. Make sure wires are tucked back in control panel for assembly
8. Carefully slide top of control panel down over holding bracket on top face of smoker.
9. Align (4) holes in bottom of control panel with brackets on smoker and reattach with (4) screws - (Figure D1)
10. Close smoker door and latch
11. Plug smoker back into an electrical outlet

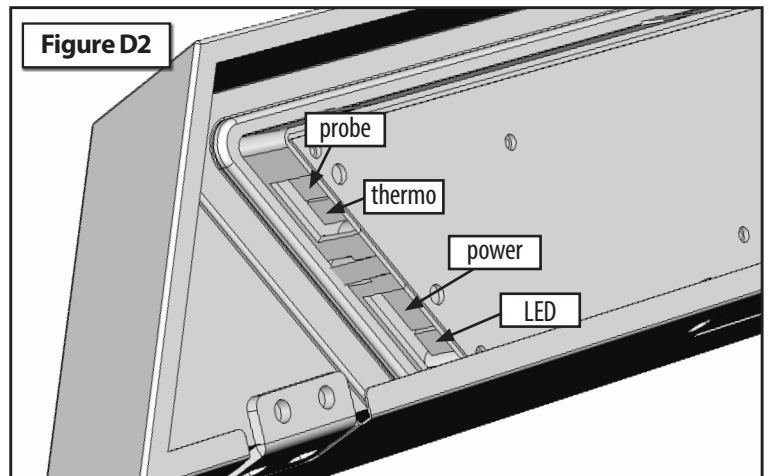
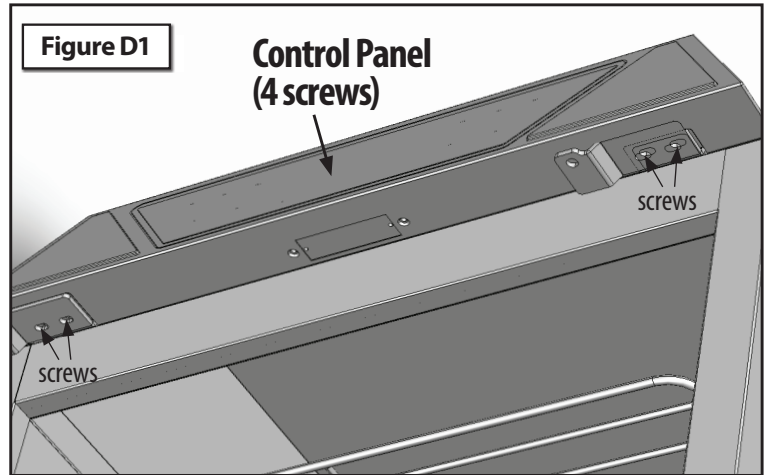

## Meat Probe Access/Replacement

### Removal:

1. Make sure your smoker is turned OFF and is unplugged
2. Unlatch and open smoker door.
3. Remove (4) screws from underside of control panel - (Figure D1)
4. Carefully lift control panel up and off of smoker. Be careful not to pull control panel far from smoker as wires are short.
5. Disconnect wire for Meat Probe (Note: Mark or remember where connector goes) - (Figure D2)
6. Carefully remove two screws holding Meat Probe bracket to smoker panel face and pull Meat Probe thru front face of smoker - (Figure D3)

### Installation:

7. Push Meat Probe thru hole in front face of smoker.
8. Position Meat Probe Plug into hole and attach Meat Probe Brackets with (2) screws. (Make sure there is enough wire to reconnect with the control panel.
9. Reconnect wire for Meat Probe to control panel - (Figure D2)
10. Make sure all wires are tucked in back of control panel for assembly

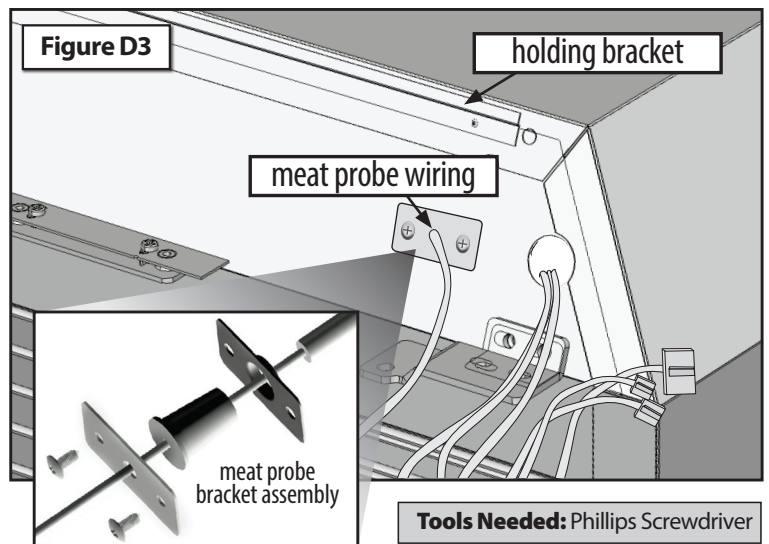

11. Carefully slide top of control panel down over holding bracket on top face of smoker. - (Figure D3)
12. Align (4) holes in bottom of control panel with brackets on smoker and reattach with (4) screws - (Figure D1)
13. Close smoker door and latch
14. Plug smoker back into an electrical outlet

# Smoking Tips

---

## Types of wood to use for smoke:

- Always use a hardwood that has been seasoned for at least 6 months.
- We recommend using Pecan, Hickory, White Oak, Apple, Alder or Mesquite.
- Never use any resin woods like Pine or Cedar.

Note: It is not necessary to soak the wood prior to smoking because hard woods have natural moisture in the wood that will release in the smoker as it heats up. In a gas smoker, soaking the wood chips may prolong the life of the wood chips but it will also take longer to produce smoke so we will leave that decision up to you. Do not soak your wood chips when using your Smoke Hollow electric smoker.

---

## What you need to smoke meats:

### Internal Meat Thermometer

An internal meat thermometer is a must to cook large pieces of meat to make sure it is done internally.

### Internal Temperatures for Select Meats

- Cooked Ham -140 degrees
- Ham, Beef-Med, Ground Beef - 160 degrees
- Veal, Lamb, Pork, Beef-Well done - 170 degrees
- Poultry - 180 degrees

### Good Tongs or Meat Hook

Use a heavy-duty set of tongs to rotate meat in the smoker because in some cases you may be smoking a very large cut of meat. I prefer a meat hook for ease of use and it does not knock any rub or sauce off of the meat.

### Good Oven Mitts

Heavy-duty mitts will assist you in moving hot smoker racks and large pieces of meats and assist in adding water and wood chips.

### Aluminum Foil

When the outside color of your meat product is at your desired color or look to suit your taste, wrap meat product in aluminum foil to keep any more wood resins from turning your meat any darker. Also it will saturate fats from your meat product.

# Smoking Techniques

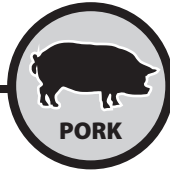

## Smoked Pork Tenderloin

Take outside wrapper off of meat and wash thoroughly in cold water. Place tenderloin on a paper towel to soak up excess water. Rub your favorite pork rub on the loin (we recommend Head Country Pork seasoning). Preheat smokers to 225 degrees and place loin in the center of the smoker. Cook until internal meat temperature reaches 165 degrees. Take out of smoker and let stand on the cutting platter until meat reaches 170 degrees serving temperature. Slice like bread in ¼" pieces and it will melt in your mouth.

## Pork Ribs- Baby Backs or Spare Ribs

Take ribs out of wrapper and drain all liquid off of the ribs and then wash in cold water. Place on cutting board and cut away any excess fat or skin from the bottom of ribs. Turn ribs with bone side up and peel the membrane from the back of the bone until all is gone. Rub your favorite pork rub on both sides of the ribs (we recommend Head Country Pork seasoning). Preheat smoker until it reaches 225 degrees and place rib bone side down in smoker. After one hour, turn the rib over with bone side up and cook for one hour. After 2 1/2 hours, depending on the color of the rib you like, pour a one inch wide strip of your favorite BBQ sauce down the length of the rib and wrap tightly in aluminum foil. Place back in smoker and check every 15 to 20 minutes to see if the rib bones separate by using your finger to pull them apart. If they pull apart with ease your ribs are done. Note: Make sure your internal temperature of your ribs are at 170°F. Take out of smoker and let stand on serving platter until cool enough to eat.



## Smoked Beef Brisket

Select a 6 to 8 lb. packer trimmed brisket that has a little marble to it but not too much. Feel free to trim as much fat as desired. Use your favorite beef rub (we recommend using Head Country All-Purpose rub) and rub it on liberally. Heat the smoker to 225 degrees and place the brisket in the smoker for 3 hours. Place brisket in an aluminum foil pan and pour approximately 8oz. of Allegro over the brisket. Cover the pan tightly with aluminum foil and continue cooking until internal meat temperature reaches 165 to 170 degrees. Take pan out of the smoker and let brisket stand. Remove brisket from pan and cut ¼" slices against the grain. Use juice from pan to pour over sliced meat or for dipping.

## Prime Rib

Select a 6 to 8 lb prime rib (we like the bone on). Rub the prime rib with your favorite beef rub (we recommend using Head Country All-Purpose rub). Pre-heat the smoker to 225 degrees and place the prime rib in the smoker. After 3 hours, place the prime rib in aluminum foil pan and cover with aluminum foil. When internal meat temperature reaches 145 degrees take out of smoker and let stand until your desired doneness is reached. Medium rare is 155 to 160 degrees. While standing, the temperature of the meat will rise internally up to 10 degrees. Slice prime rib to desired thickness and serve with juice from the pan in which it was cooked.

# Smoking Techniques



## Smoked Halibut

Select a nice fresh  $\frac{3}{4}$ " thick filet. Wash filet thoroughly in cold water and lay on paper towel until water is not visible. Melt a whole stick of butter in the microwave and sprinkle a liberal amount of Dill weed in the melted butter. Lay filets on aluminum foil and fold a lip around edges to contain the butter. With a basting brush, brush melted butter and dill weed mixture on both sides of the fish filet. Preheat smoker to 225 degrees and place fish in the smoker. Check the filets every 15 minutes for visible moist look on filets. Brush with butter and dill weed mix when needed. Fish should start to flake in about 45 minutes. When fish flakes very easy take out of smoker and serve.

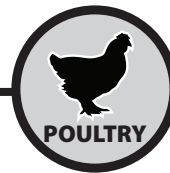

## Smoked Chicken

Chicken breasts and thighs are my favorite. Take chicken parts out of package and wash thoroughly and place on paper towel to dry. Sprinkle Head Country Original rub on both sides of chicken parts. Preheat smoker to 225 degrees and place chicken parts in smoker. After  $\frac{1}{2}$  hour turn chicken over. With your internal temperature gauge, check internal temperature by pushing temperature probe into the meat nearest the bone. When temperature reaches 180 degrees chicken is done. You may brush your favorite BBQ sauce on the chicken during the last 15 minutes of your cooking process to spice it up.

## Smoked Turkey

Select a 12 to 15 lb. turkey for best results in a smoker. Take the turkey out of the package and remove all internal parts and packaging. Wash turkey thoroughly and place it on paper towel to dry. Rub olive oil inside and out on the turkey and apply Head Country Original Rub inside body cavity and on the outside skin. Preheat smoker to 225 degrees and place turkey in smoker. You may baste with butter for more moisture, if you like. When turkey skin reaches your desired color, remove turkey from smoker, place in aluminum foil pan and cover with aluminum foil tightly. Place covered pan in smoker and continue cooking at 225 degrees. Check internal meat temperature, where the thigh meets the side of the turkey, every half hour for doneness. Turkey should take around 45 minutes per lb to reach 180 degrees serving temperature.

# Cold Smoking Recipes

## Smoked Cheddar Cheese

### Ingredients

Brick of Cheddar Cheese (Old or Aged cheddar is preferred - substitute Gouda or Fontina for a change of flavor.)

### Preparation

Place cheese on racks and load into your Smoke-Tronix smoker by Smoke Hollow®.

### Smoking Method

1. Fill the wood chip tray with your favorite wood chips.
2. Open the back and lower vents completely.
3. Push the fast smoke button and set your time, temp and probe if desired.
4. It is best to keep the internal temp lower than 100° F when smoking cheese.
5. If the internal temp is too hot, you may need to place a pan of ice under your cheese rack to help reduce the internal temp or open the door slightly.
6. Smoke for approximately 40 to 60 minutes.

## Cold Smoked Salmon Serves 8-10 as an appetizer

### Ingredients

- 2 to 3 pounds fresh salmon fillet (preferably from the head end)
- 1 1/2 cups coarse sea salt or kosher salt
- 1 1/2 cups brown sugar

### Optional Garnishes

- Diced red onion, Sliced lemons, Chopped fresh dill or Sour cream

### Preparation

1. Run your fingers over the flesh side of the salmon fillets, feeling for the sharp ends of pin bones. Pull out any you find with fish tweezers or needle nose pliers.
2. Make the cure: Combine the salt and brown sugar in a mixing bowl and mix with your fingers. Spread 1/3 of the cure over the bottom of a glass baking dish just large enough to hold the fish. Lay the salmon fillets on top of the cure. (The cure should extend 1/2 inch beyond the edges of the fish on each side.) Spread the remaining cure on top so it covers the fish completely.
3. Cover the dish with plastic wrap and cure the fish in the coolest part of your refrigerator for 24 to 48 hours.
4. Gently rinse the cure off the salmon under cold running water. Place the salmon in a large bowl with cold water to cover by 3 inches. Soak for 30 minutes, then drain well in a colander.
5. Blot the salmon dry on both sides with paper towels. Arrange it skin side down on a wire rack over a sheet pan. Let the salmon dry, uncovered, in the refrigerator until it feels tacky, about 4 hours.

### Smoking Method

1. Fill the wood chip tray with your preferred flavor of wood chips. Beechwood or Alder are good choices for salmon.
2. Open the back and lower vents completely.
3. Push the fast smoke button and set your time, temp and probe if desired.
4. If the internal temp goes above 100°, you may need to place a pan of ice under your salmon rack to help reduce the internal temp or open the door slightly.
5. Cold smoke the salmon until the exterior is bronzed with smoke and the salmon feels semi-firm and leathery, 12 hours or more. How will you know it's ready? Cut a slice from next to the skin at the fat end.
6. Wrap salmon in uncoated butcher paper and let rest in the refrigerator for at least 4 hours before serving or overnight.
7. Using a long, slender and sharp knife held sharply on the diagonal to the fish, cut the salmon into paper-thin slices.

# Limited Warranty

---

This Smoke Hollow® smoker is guaranteed against broken or damaged parts at time of purchase. All parts carry a 1-year limited warranty. Paint is guaranteed to be free of defects for 90 days except for rust, which may appear after repeated use.



This warranty does not cover damage or issues related to neglect, abuse, or modifications to the product. Repair labor is not covered.

All parts that meet the warranty requirements will be shipped at no-charge via the discretion of the Customer Service Department (ground shipments, US Mail, or Parcel Post Only). Any special handling charges (i.e. Second Day, Overnight, etc.) will be the responsibility of the consumer.

All warranty claims apply only to the original purchaser and require a proof of purchase verifying purchase date. Do not return parts to our address without first obtaining a return authorization number from our customer service.

This service is available by calling 866-475-5180, 8:30am to 4:30pm, Central Time, Monday through Friday, or write to Outdoor Leisure Products, Inc., 5400 Doniphan Drive, Neosho, MO 64850.

This warranty may give you specific legal rights that vary by state.

---

**Outdoor Leisure Products, Inc**  
5400 Doniphan Drive  
Neosho, MO 64850  
[www.olp-inc.com](http://www.olp-inc.com)

© 2015 Outdoor Leisure Products, Inc. No part of this work may be reproduced, modified, distributed, or otherwise used without prior written permission. Smoke Hollow and Smoke-Tronix are trademarks of Outdoor Leisure Products, Inc. The Bluetooth® word mark and logos are registered trademarks owned by Bluetooth SIG, Inc. and any use of such marks by Outdoor Leisure Products, Inc. is under license. Apple, the Apple logo, iPhone, iPad, and iPod touch are trademarks of Apple Inc., registered in the U.S. and other countries. App Store is a service mark of Apple Inc. Google Play is a trademark of Google Inc.