

# Deluxe Outdoor

## Assembly & Operation

### Grill & Smoker SH5000



Conforms to ANSI STD Z21.58b-2012  
OUTDOOR COOKING GAS APPLIANCE

**Intertek**



**Tools needed for assembly:**  
Phillips screwdriver, Pliers or Adjustable Wrench

**⚠ DANGER ⚠**

If you smell gas:



1. Shut off gas to the appliance.
2. Extinguish any open flame.
3. Open lid.
4. If odor continues, keep away from the appliance and immediately call your fire department.

Failure to follow these instructions could result in fire or explosion which could cause property damage, personal injury or death.



**⚠ DANGER ⚠**

1. Never operate this appliance unattended.
2. Never operate this appliance within 10 ft (3.0 m) of any structure, combustible material or other gas cylinder.
3. Never operate this appliance within 25 ft (7.5 m) of any flammable liquid.
4. Do not fill cooking vessel beyond maximum fill-line.
5. Never allow oil or grease to get hotter than 400°F or 200°C. If the temperature exceeds 400°F (200°C) or if oil begins to smoke, immediately turn the burner or gas supply OFF.
6. Heated liquids remain at scalding temperatures long after the cooking process. Never touch cooking appliance until liquids have cooled to 115° F (45°C) or less.
7. If a fire should occur, keep away from the appliance and immediately call your fire department. Do not attempt to extinguish an oil or grease fire with water.

Failure to follow these instructions could result in fire or explosion which could cause property damage, personal injury or death.



 **WARNING** 

For Outdoor Use Only  
(outside of any type of enclosure)

 **WARNING** 



If you smell gas –

- Turn off the gas supply to the appliance
- Extinguish any and all open flames
- Open the Lid of the Grill
- If the odor remains, stay away from the grill and notify your gas supplier and/or the Fire Department.

 **WARNING** 



- Do not use or store gasoline, kerosene, alcohol, or other flammable liquids or vapors in the vicinity of this appliance or any other appliance.
- Any LP Gas Cylinder NOT connected for use with the appliance, shall not be stored in the same vicinity of this or any other appliance.

A LP Propane Gas Cylinder is needed for operating the gas side of this grill.  
The LP Gas Cylinder is NOT included.  
This gas grill is only intended for Domestic use, not to be used for any commercial purpose.



 **DANGER** 

- Never use the gas or charcoal grill for INDOOR cooking or heating
- Never use the grill on or in a boat or recreational vehicle

The combustion fumes from either the gas or charcoal grill are toxic and can cause severe illness and possibly death.



 **WARNING** 

The combustion of Propane gas can yield the formation of chemical compounds known in the state of California, U.S.A., to cause birth defects, cancer, and other serious health matters.



 **WARNING** 

Read this installation manual before assembling or servicing this appliance.

Failure to follow these instructions may result in an faulty installation, which could cause damage to property, personal injuries or even death.

 **IMPORTANT** 

Save these instructions after reading them in case you need to refer to them in the future.

 **WARNING** 

**CALIFORNIA PROPOSITION 65**  
Combustion by-products produced when using this product contain chemicals known to the State of California to cause cancer, birth defects, and other reproductive harm.



***Read all safeguards and assembly instructions before assembling and operating your grill/smoker.***

***Before assembling your new grill/smoker, unpack all the parts from the box. Carefully remove all packing material and lay out all the parts for easy access and identification. Do not discard the carton or packaging until your smoker is fully assembled and operating to your satisfaction.***

***In order to properly assemble your smoker, you will only need two tools:***

- *Phillips head screwdriver*
- *Pliers or adjustable wrench (tools not included)*

***The grill/smoker is heavy and must be moved around during assembly and before use. Be sure to have a friend help.***

Outdoor Leisure Products, Inc.  
5400 Doniphan Drive  
Neosho, MO 64850  
Toll Free: 866-475-5180  
Website: [www.olp-inc.com](http://www.olp-inc.com)



8:30am to 4:30pm, Central Time  
Monday through Friday

## **SAFETY WARNINGS**

1. The installation of this grill must conform to local codes, or in the absence of local codes, with either the *National Fuel Gas Code, ANSI Z223.1 / NFPA 54, Natural Gas and Propane Installation Code, CSA B149.1, or Propane Storage and Handling Code, B 149.2, or The Standard for recreational Vehicles, ANSI 119.2 / NFPA, and CSA Z240 RV Series, Recreational Vehicle Code, as Acceptable.*
2. The Gas Grill side of the grill /smoker is for use with LP (Propane) Gas ONLY! LP Gas Cylinder is NOT included with the Grill.
3. Never use lighter fluid, gasoline, kerosene, or alcohol for lighting the gas grill.
4. The LP Gas supply Cylinder used must be constructed and marked in accordance with the *Specifications of the U.S. Department of Transportation (D.O.T.) or The Standard for Cylinders, Spheres and Tubes for Transportation of Dangerous Goods; and Commission, CAN/CSA-B339, as applicable.* It MUST be provided with a Listed Overfilling Device. Only use 20 pound cylinders that have a type 1 cylinder connection device compatible with the Connection for Outdoor Cooking Appliances.
5. The LP gas cylinder must be arranged for vapor withdrawal, purging and have an overfilling prevention device.
6. LP Gas Cylinders must be stored outdoors, out of the reach of children, and must not be stored in a building, garage or any other enclosed area.
7. The Pressure regulator and Hose Assembly supplied with the Grill, must be used. Any replacement regulator and hose assemblies must be those specified by the outdoor cooking gas appliance manufacturer.
8. The LP Gas Cylinder must include a collar to protect the cylinder valve.
9. Do not store a spare LP Gas Cylinder under or near this grill.
10. Never fill the LP Gas Cylinder beyond 80% full. For vapor withdrawal /purging, The cylinder should be in the upright position.
11. This outdoor cooking gas appliance must only be used outdoors, and must not be used in a building, garage or any enclosed area
12. The following distances for proper clearance must be maintained :
  - Minimum distance from back and sides of the outdoor cooking gas appliance \_to walls is 36" ( 1 meter )
  - Do not use under any overhead combustible constructions
  - For outdoor use only
  - Remove LP Gas Cylinder from grill if storing grill indoors
13. This outdoor cooking gas appliance is not intended to be installed in or on boats
14. Inspect the Gas Hose before each use. If the Hose has any leak, cut or wear, it must be replaced BEFORE using the grill
15. Do not try to move the grill while either gas, charcoal or smoker firebox is lit.
16. Wait one hour minimum before touching any metal parts, until they are cool.
17. NEVER leave the grill unattended when in use.
18. Keep children and pets away from the grill when in use.
19. **Note: Grease Drip Trays and Grease Cup should be emptied and cleaned after each use to prevent flare – ups and /or grease fires.**

**IF THESE INSTRUCTIONS ARE NOT FOLLOWED EXACTLY, A FIRE CAUSING DEATH OR SERIOUS INJURIES MAY OCCUR!**

**READ ALL SAFEGUARDS AND INSTRUCTIONS THOROUGHLY!**  
**YOUR SAFETY IS VERY IMPORTANT – FAILURE TO FOLLOW PROPER PROCEDURES AND SAFEGUARDS MAY RESULT IN PROPERTY DAMAGE, PERSONAL INJURY OR DEATH.**

 <b>DANGER</b>	<b>DANGER</b> 
<ul style="list-style-type: none"> <li>. The GRILL is for outdoor use only!</li> <li>. Do NOT use this grill for other than its intended purpose.</li> <li>. Do not leave grill unattended when in use.</li> <li>. Do not use gasoline, kerosene or alcohol for lighting charcoal, use of any of these or similar products may cause an explosion possibly leading to severe bodily harm.</li> <li>. Never operate this grill under any overhead roof covering, awning or overhang. Never use inside an enclosed area such as screen patios, garages, buildings or tents.</li> <li>. Keep the area clear of all flammable liquids, combustible material including but not limited to wood, dry plants including grass, brush, paper, and canvas.</li> <li>. Grill is HOT while in use and after use – Avoid touching hot surfaces. Always wear protective gloves or mitts when operating the smoker.</li> <li>. Keep children and pets away from the grill at all times.</li> <li>. Do not allow anyone to conduct activities around the grill during or following its use until the unit has cooled. The grill is hot during operation and remains hot for a period of time following its use.</li> <li>. Always wear shoes and protective clothing during operation of this smoker.</li> <li>. Never use glassware, plastic, or ceramic cookware in this grill.</li> <li>. The firebox lid will be extremely hot.</li> <li>. When grilling, grease from meat may drip into the charcoal and cause a grease fire. If this should happen, close the lid and dampers to suffocate the flame.</li> <li>. Do not use water to extinguish grease fires.</li> </ul>	<ul style="list-style-type: none"> <li>. Do not move the unit while it is being used.</li> <li>. Do not use in windy conditions.</li> <li>. Use caution when opening the lid, as hot steam or a flame flare-up could cause burns.</li> <li>. Before each use, make sure the unit is in good working condition.</li> <li>. Use caution after the fire has been extinguished, the surface will remain hot for some time.</li> <li>. Be sure all charcoals are cold before emptying, if necessary pour water on coals before moving grill.</li> <li>. Store the grill out of reach of children and in a dry location when not in use.</li> <li>. Check grease and or ash level in ash pan often and empty. Use extreme caution as the smoker, and metal ash pan will be hot.</li> <li>. When opening the lids, keep hands, face and body a safe distance from hot steam and flame flare-ups.</li> <li>. Do not allow charcoal and or wood to rest on the walls of the firebox and cooking chamber. Doing so will greatly reduce the life of the metal and finish of you smoker.</li> <li>. Close lids and all dampers to suffocate flame.</li> <li>. Never leave coals and ashes in grill unattended. Before grill can be left unattended, remaining coals and ashes must be removed from smoker.</li> <li>. Use caution when lifting or moving smoker to prevent strains and back injuries.</li> <li>. Properly dispose of all packaging material.</li> </ul>

USE CAUTION AND COMMON SENSE WHEN OPERATING YOUR SMOKER. READ ALL INSTRUCTIONS, WARNINGS AND SAFEGUARDS PRIOR TO ASSEMBLING AND OPERATING YOUR SMOKER.

**SAVE THESE INSTRUCTIONS**

# SH5000 Parts List

**Note:** For assistance, including missing or damaged parts, call toll free - 866-475-5180 from 8:30 am - 4:30 pm Central Time, Monday - Friday

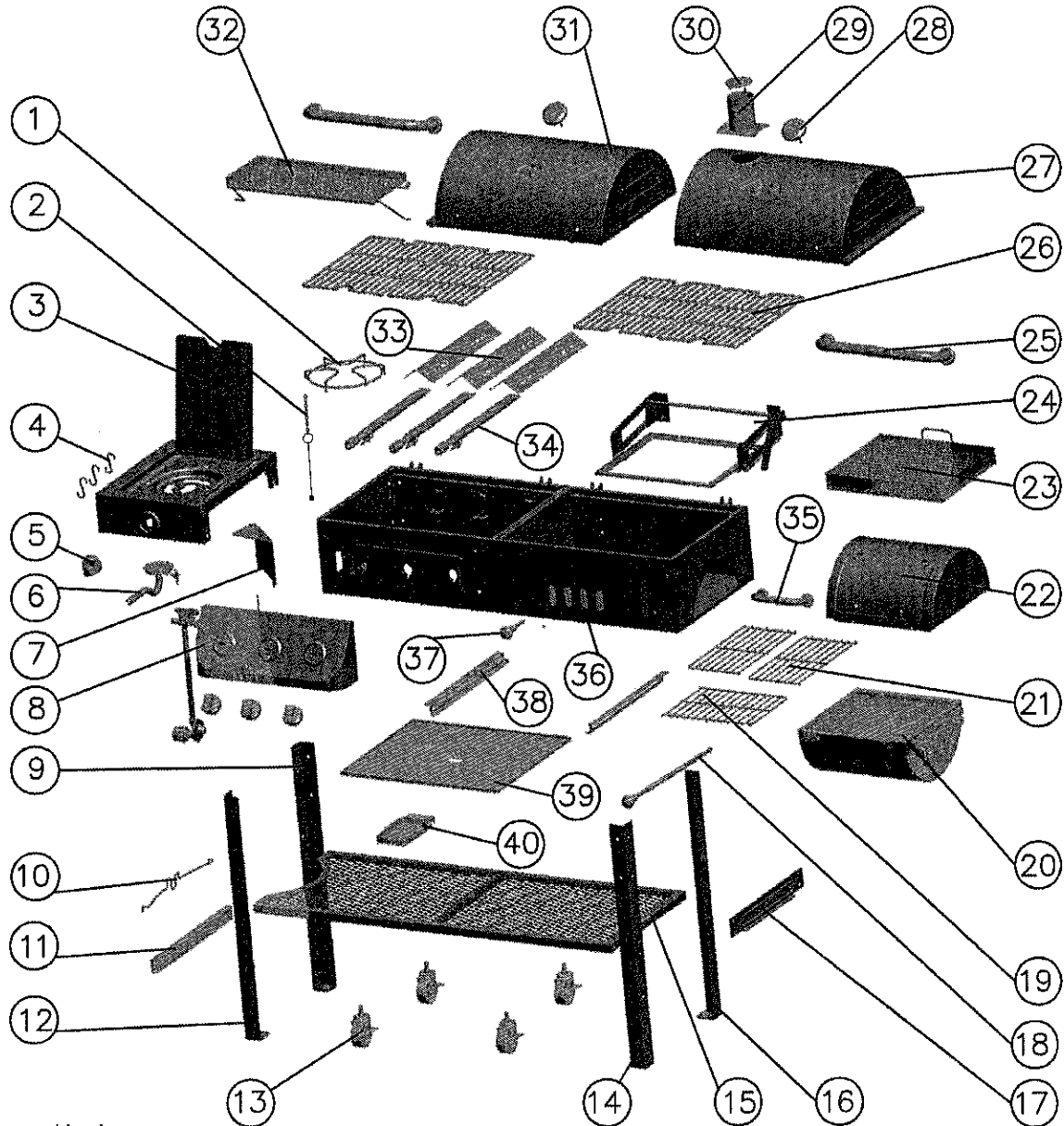

**Hardware Pack**

Quantity	Description
62	M6x15 Combo Truss Head Bolts, Black Nickel Plated
6	M6x15 KEPS Combo Truss Head Bolts, Black Nickel Plated
8	M6 KEPS Nuts Black Nickel Plated
2	M4x8 Combo Truss Head Bolts, Black Nickel Plated
3	ST4.0*10 Combo Head Screws
2	M6x30 Combo Truss Head Bolts, Black Nickel Plated
6	"R" Clips, Black Nickel Plated
1	Small Spring, Black Nickel Plated
1	Wrench For Caster Assembly
1	M6 Cap Nut, Black Nickel Plated
4	Long Hinge Pins ,Black Nickel Plated
2	Short Hinge Pins ,Black Nickel Plated

# SH5000 Parts List

Item NO.	Quantity	Description	Part NO.
1	1	Side Burner Wire Grid Rack	1800CGS-1
2	1	Match Holder	TR029
3	1	Side Burner Housing	SH5000-15
4	3	"S" Hanging Hooks	SH5000-01
5	4	Gas Valve Control Knobs	TR037
6	1	Side Burner Assembly	1800CGS-2
7	1	HVR Cover	47183T-03
8	1	Control Panel— 4 Valves ,Electronic Ignitor and HVR	SH5000-5
9	1	Left Rear Leg	1800CGS-8
10	1	LP Gas Cylinder Wire Retainer	1800CGS-10
11	1	LP Gas Cylinder Bottom Support Brace	1800CGS-11
12	1	Left Front Leg	1800CGS-9
13	4	Locking Casters	1800CGS-12
14	1	Right Front Leg	1800CGS-24
15	1	Bottom Mesh Shelf	SH5000-14
16	1	Right Rear Leg	1800CGS-13
17	1	Fire Box Support Brace	1800CGS-7
18	1	Charcoal Tray Adjuster Handle	TR019
19	1	Firebox Wood Rack	1800CGS-38
20	1	Firebox Bottom Half Assembly	1800CGS-39
21	2	Firebox Cooking Grids	1800CGS-37
22	1	Firebox Top Half Assembly	1800CGS-35
23	1	Charcoal Tray Assembly	47183T-21
24	1	Charcoal Tray Lifting System	TR020
25	2	Gas and Charcoal Grill Lid Handles	TR049
26	4	Grill Cooking Grids	47183T-11
27	1	Charcoal Grill Lid	SH5000-7
28	2	Heat Indicators	TR041
29	1	Smoker Stack Assembly	SH5000-8
30	1	Smoker Stack Lid	SH5000-9
31	1	Gas Grill Lid	SH5000-10
32	1	Warming Rack	SH5000-11
33	3	Burner Heat Tents	47183T-24
34	3	Stainless Steel Burners	47183T-02
35	1	Firebox Lid Handle	1800CGS-36
36	1	Gas and Charcoal Grill Cabinet Assembly	SH5000-2
37	1	Damper Control Knob	TR036
38	2	Side Gas Grill Bottom Tray Support Bracket	SH5000-12
39	1	Gas Grill Grease Tray	SH5000-13
40	1	Removable Grease Cup	1800CGS-26
41	1	Hardware Blister Card	SH5000-03
42	1	Instruction Manuals	SH5000-04

# Assembly

**Note:** Carefully cut the tape holding the carton together. Cut the carton so that it can lay flat on the ground to provide a clean surface for assembling your Grill. Remove the packing materials and all the parts from inside the Cabinet. After unpacking all the parts, check to make sure you HAVE all the parts. If anything is damaged or missing, contact our toll free number: 866-475-5180. Discard all packing material in a safe and recyclable manner. Save this Assembly Manual for future reference.

Tools Required: Phillips Head Screwdriver, Adjustable Wrench or Pliers

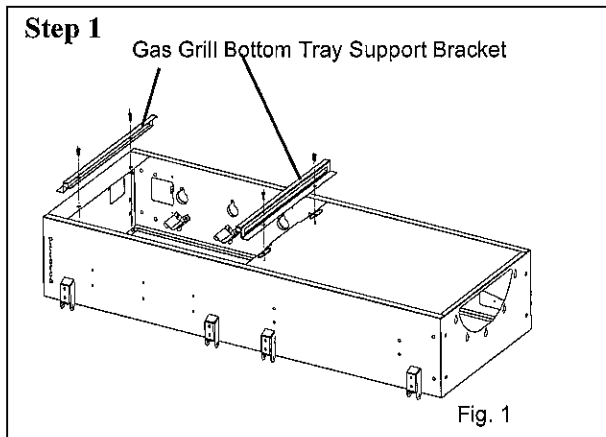

## Step 1: Assembly of Gas Grill Bottom Tray Support Brackets to the Gas Grill Cabinet

*Locate:* (2) Gas Grill Bottom Tray Support Brackets, (4) M6x15 Bolts

*Procedure:*  
Position the Gas and Charcoal Cabinet upside down. Refer to Fig.1 and attach the Brackets as shown using (4) M6x15 bolts.

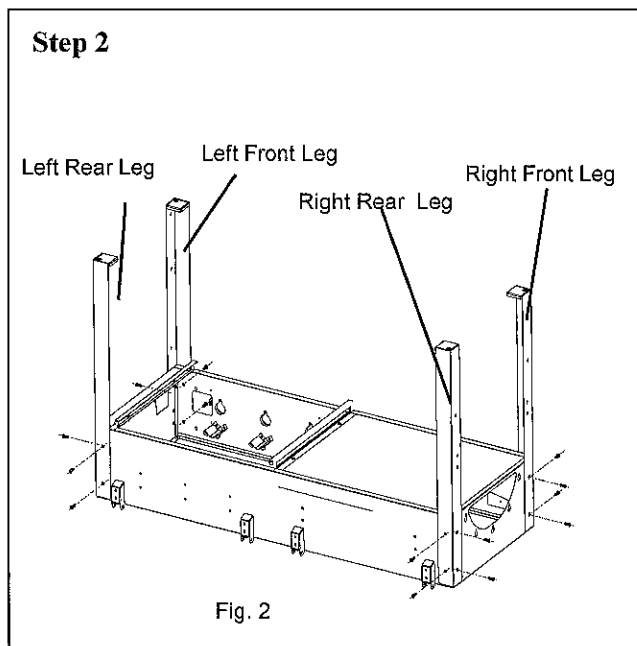

## Step 2: Leg Assembly

*Locate:* Note- each leg will have an identification label on it. (4) Legs, (14) M6X15 bolts

*Procedure:*  
Refer to Fig. 2- Attach the Left Front Leg and the Left Rear Leg as shown using (3) M6\*15 bolts for each leg and attach the Right Front Leg and Right Rear Leg, using (4) M6x15 bolts for EACH leg.

*Note:* The Left Legs are attached to the gas grill and the Right Legs are attached to the charcoal grill.

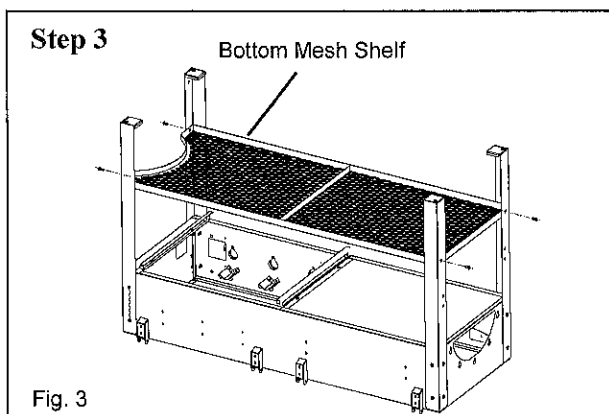

## Step 3: Attach Bottom Mesh Shelf

*Locate:* Bottom Mesh Shelf, (4) M6x15 bolts.

*Procedure:*  
Refer to Fig. 3 and attach the Bottom Mesh Shelf to the Legs as shown using (1) M6x15 bolt in each hole at both ends of the Shelf



# Assembly

## Step 4

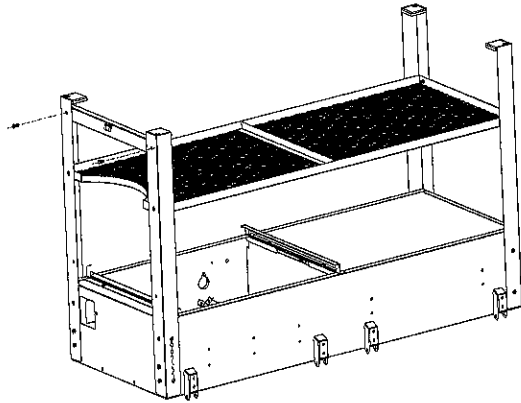

Fig. 4

## Step 4: Attach LP Gas Cylinder Bottom Support Brace

*Locate:* The tubular Support Brace, (2) M6x15 bolts

*Procedure:*

Refer to Fig. 4 and attach the Support Brace to the **INSIDE** of the Left Side Front and Rear Legs using (1) M6x15 bolt at each end of the Brace

## Step 5

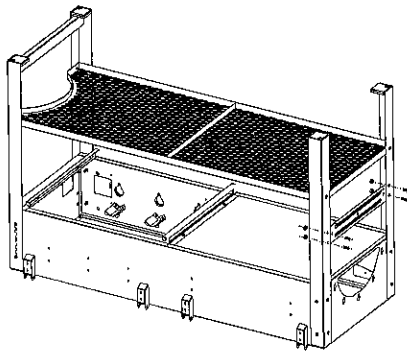

Fig. 5

## Step 5: Attach Fire Box Support Brace

*Locate:* Fire Box Support Brace, (4) M6x15 bolts, (4) M6 KEPS nuts

*Procedure:*

Refer to Fig. 5 and Place the Fire Box Support Brace **BETWEEN** the Legs on the **RIGHT** side of the Cabinet, so that the **LEDGE** is at the **TOP** and facing through the Legs. Fasten to **BOTH** legs with (2) M6x15 bolts and (2) M6 KEPS nuts on each Leg

## Step 6

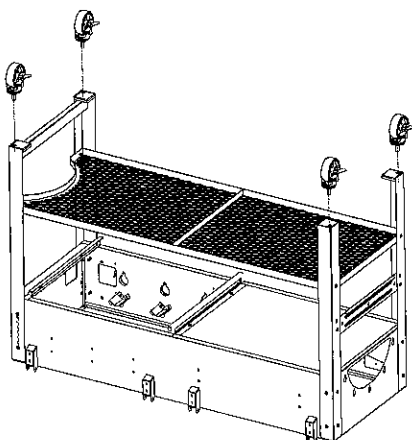

Fig. 6

## Step 6: Attaching Casters

*Locate:* (4) Locking Casters

*Procedure:*

Refer to Fig. 6 and screw a Caster onto each Leg, then tighten with a wrench.

**Note:** LOCK ALL CASTERS BEFORE GOING TO STEP 7

Then turn assembly right side up .

# Assembly

## Step 7

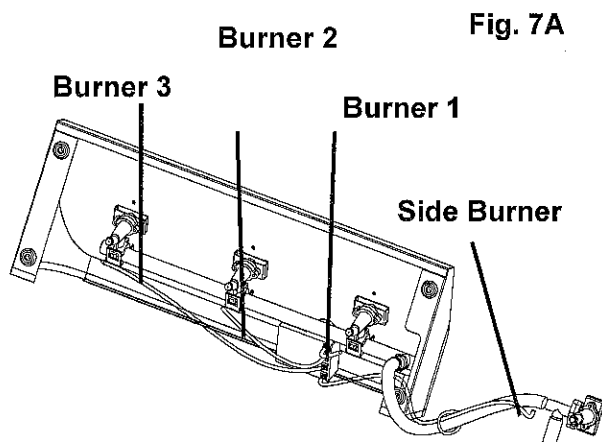
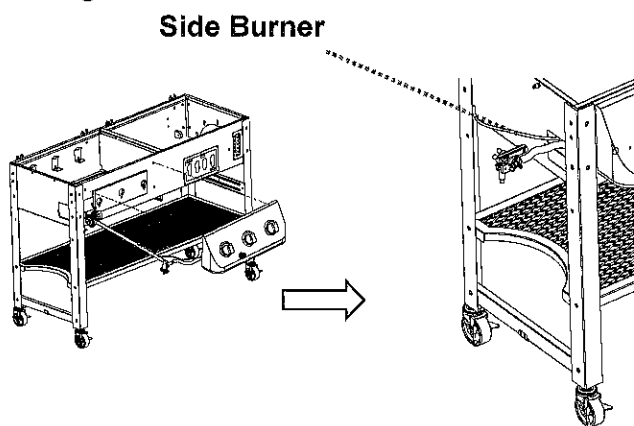

Fig. 7A

Fig. 7B



Side Burner

Fig. 7C

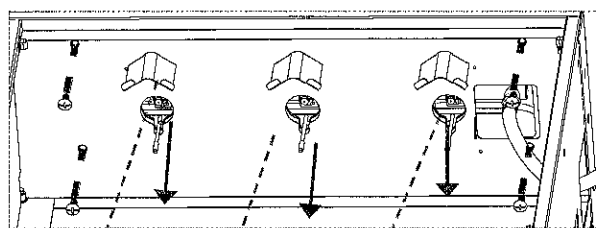

Burner 3    Burner 2    Burner 1

## Step 7: Installing the Control Panel Assembly

*Locate:* Fig. 7A shows the inside of the Control Panel Assembly (CP has (3) gas valves mounted on a manifold connected to the Hose, Side Burner Valve and Regulator assembly (HVR). There is an Electronic Ignition assembly attached, which has (4) igniter wires, of different lengths, to attach to each burner tube and the Side Burner and (4) M6x15 bolts.

*Procedure:* Refer to Fig. 7B and carefully thread the HVR with the Side Burner igniter wire through the opening in the front face of the Grill, make a turn to the left and bring it out through the opening in the left side of the Grill. Allow it to hang free, as we will later make the connection to the Side Burner.

Refer to Fig. 7C, and note that at each opening for the valve and burner connection, there is a small keyhole slot. The Burners are numbered 1 to 3, starting with # 1 as the Left Burner. Carefully push each of the ignition wires through the holes to dangle inside, resting in the keyhole slot. The shortest wire is # 1 and the longest is for # 3. We will attach these wires to each burner tube when we install the burners. Check to be certain that no wires have become disconnected from the Igniter Housing.

Position the Control Panel in place against the Front Panel and fasten it with (4) M6x15 bolts from inside the Grill – see Fig. 7C.

# Assembly

## Step 8

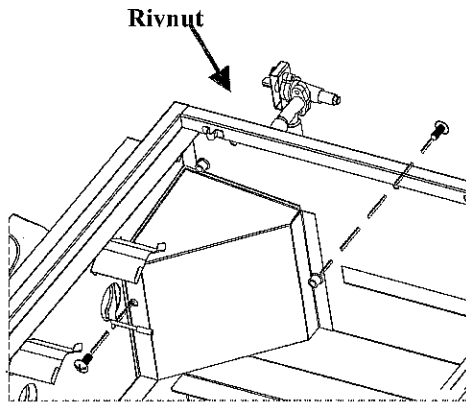

## Step 8: Attaching the HVR Cover

*Locate:* HVR Cover and (2) M6x15 bolts

*Procedure:* Refer to Fig. 8 and set the HVR Cover in the front corner of the Gas Grill Cabinet, so that it covers the actual HVR where it enters and exits the Cabinet. Fasten in place with (2) M6x15 bolts.

Be sure top of cover is positioned under the rivnut as shown.

## Step 9

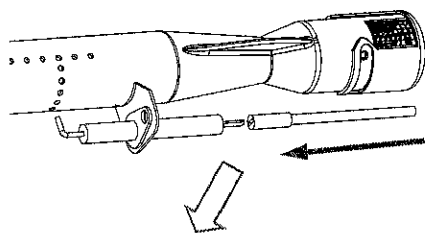

Fig. 9A

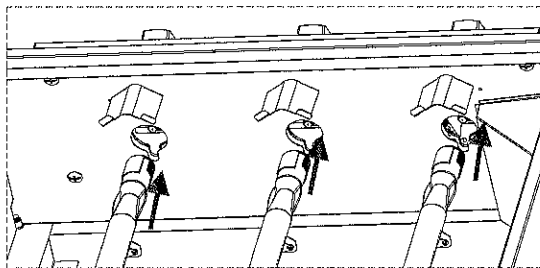

Fig. 9B

Fig. 9C

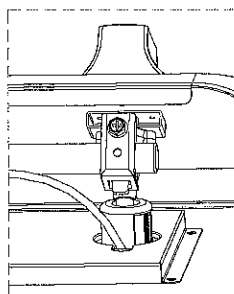
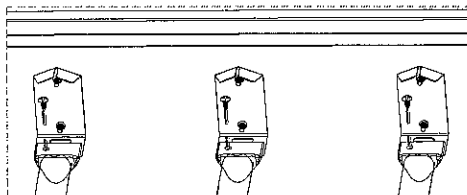

Fig. 9D



## Step 9: Attaching the Burner Tubes to the Grill

*Locate:* (3) Burner Tubes with Igniter electrodes attached and (3) ST 4.0x10 Screws.

*Procedure:* Attached to each Burner Tube is an Ignition Electrode with a pin at the end of the Electrode. You need to attach each of the (3) ignition wires that you had pushed through the openings onto the pin end of the Electrode per Fig. 9A.

Refer to Fig. 9B and Fig 9C. Tilt the burner tube slightly and insert through the opening in the front wall of the cabinet. You **MUST** make certain that the tip of the valve is completely **INSIDE** the end opening of the Burner Tube.

After each Burner Tube is set in place at the front of the Cabinet, you must fasten the Burner Tube to the Burner Support Brackets at the back of the cabinet with an ST 4.0x10 screw per Fig. 9D.

# Assembly

## Step 10

Fig.10A

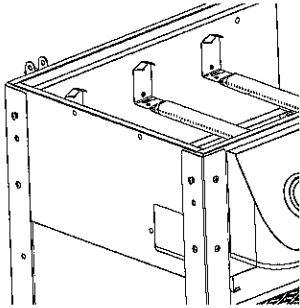

Fig.10B

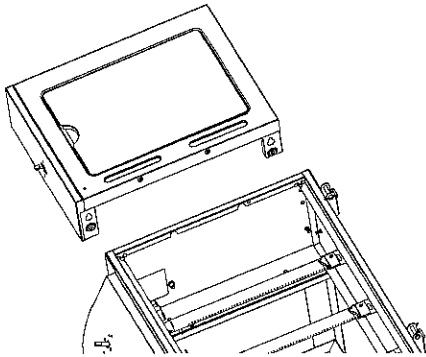

Fig.10C

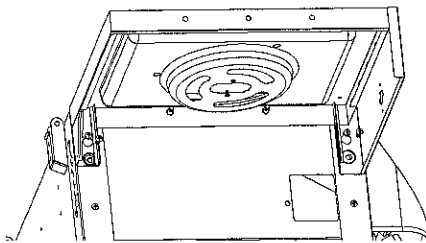
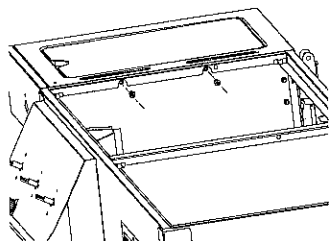

Fig.10D



## Step 10: Attach the Side Burner Housing

*Locate:* Side Burner Housing, (6) M6x15 bolts

*Procedure:*

Refer to Fig. 10A, Screw in the (2) M6x15 bolts into the top (2) holes in the left side legs of the cabinet. BUT, leave about 1/8<sup>th</sup> of the bolt sticking out, as shown.

Refer to Fig.10B, Position the Burner Housing over the (2) bolt heads and into the (2) Keyhole openings. Slide the Housing down to fit the bolts into the slots, and tighten the bolts to secure the Housing to the Grill as seen in Fig. 10C. Now attach (2) M6x15 bolts into the (2) bottom holes.

Refer to Fig.10D. Using another (2) M6x15 bolts, attach the Side Burner, from inside the cabinet.

# Assembly

## Step 11

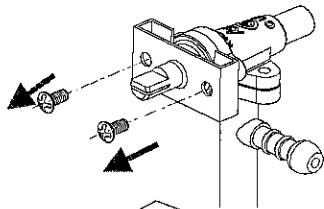

Fig.11A

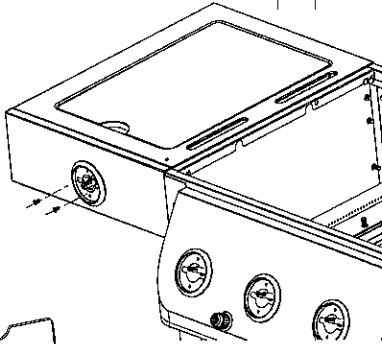

Fig.11B

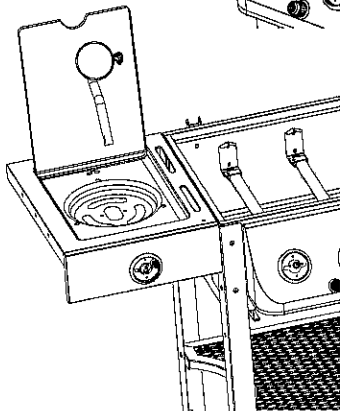

Fig.11C

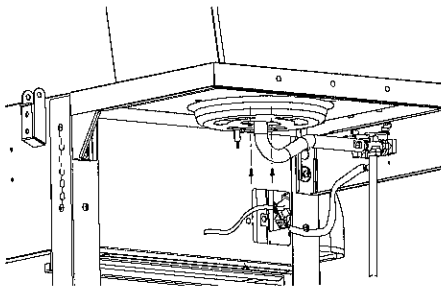

Fig.11D

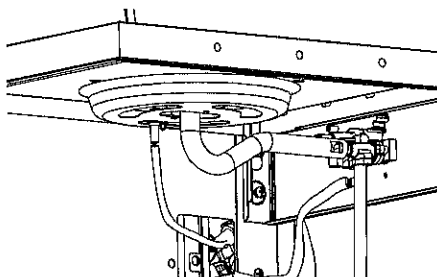

Fig.11E

## 11: Assemble the Side Burner Gas Burner Unit

*Locate:* (1) Side Burner Housing ( already attached to the Cabinet), Hose, Valve and Regulator Assembly (HVR), Igniter with wire, Burner assembly, (2) M4x8 screws.

*Procedure:*

Refer to Fig. 11A – Pick up the HVR and hold the Gas Valve in your hand and UN-SCREW the (2) M4x6 screws.

Refer to Fig. 11B – Position the valve in place between the front panel of the Side Burner and the inner wall. Align the threaded holes in the valve with the holes in the Side Burner Housing and attach the valve using the (2) M4x6 screws that were removed earlier.

Refer to Fig. 11C and insert the Burner and Igniter assembly by passing the tube portion DOWN from the top of the Housing into the Housing. Then turn the Burner Assembly so that the tube end is positioned completely over the Gas Valve Tip.

Refer to Fig. 11D and make certain that the VALVE TIP is INSIDE the tube. Attach the Burner Assembly to the Burner Housing with (2) M4X8 screws from the UNDERSIDE of the housing as shown.

Refer to Fig 11E and insert the Igniter Wire into the Valve connection opening.

# Assembly

## Step 12

Fig.12

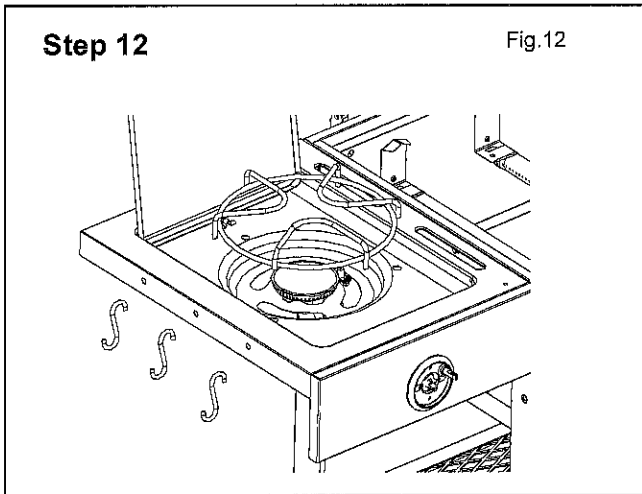

## Step 12: Assemble the Side Burner Gas Burner Unit

*Locate:* Side Burner Wire Grid Rack and (3) "S" Hooks.

*Procedure:* Refer to Fig.12. And position the Side Burner Wire Grid Rack in place, over the burner, and into the (3) holes. Hang the (3) "S" Hooks onto the side as shown.

## Step 13

Fig.13

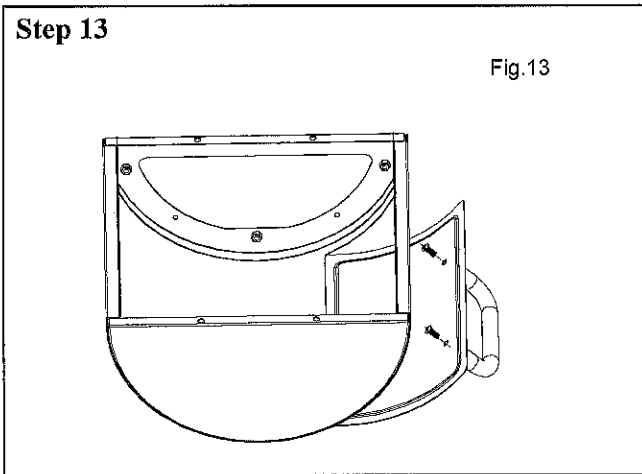

## Step 13: Attach Firebox Lid Handle

*Locate:* Firebox Lid Handle, (2) M6x15 bolts

*Procedure:*  
Refer to Fig.13 Lift the Lid up and insert (2) M6x15 bolts from the INSIDE of the Lid to attach the Handle and Lid into the (2) holes.

## Step 14

Fig.14

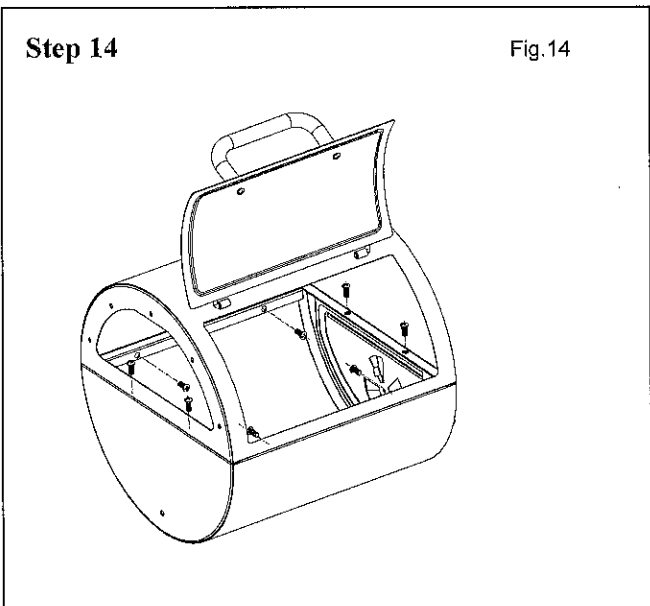

## Step 14: Assemble the Firebox

*Locate:* Firebox Top and Bottom halves, (8) M6x15 bolts

*Procedure:*  
Refer to Fig. 14 Note- the clean-out door is in the BOTTOM half and facing to the RIGHT. The smoke passage opening is in the TOP half and is facing to the LEFT. Fasten the two halves together with (8) M6X15 bolts as shown.

# Assembly

## Step 15

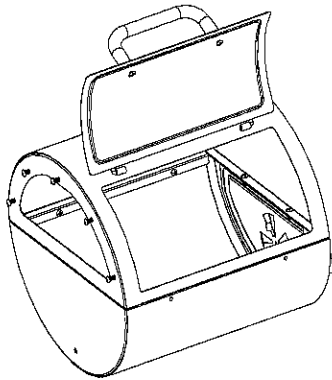

Fig.15A

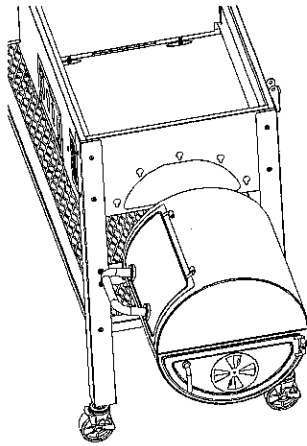

Fig.15B

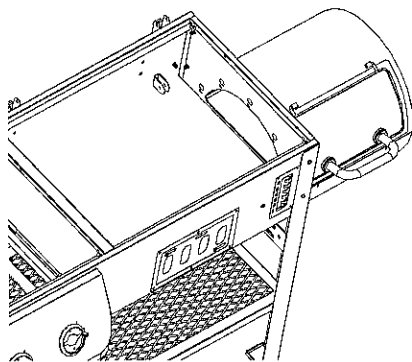

Fig.15C

### Step 15: Attach the Firebox to the Charcoal Grill Side

*Locate:* Assembled Firebox and Right Side of the Charcoal Grill, (6)M6X15 KEPS bolts

*Procedure:*

Refer to Fig. 15A and screw (5) M6x15 KEPS bolts into the (5) threaded holes in the side of the Firebox, allowing about a 1/4" of an inch of the bolt head to remain sticking out.

Refer to Fig. 15B and place the Firebox in position so that the (5) bolt heads can fit into the KEYHOLES, allow the Firebox to move down, so the bolts slide into place in the slots and the bottom of the Firebox rests on the Ledge of the Bracket.

Refer to Fig.15C and fasten (1) M6x15 KEPS bolt through the Bracket and into the Firebox to secure it in place. Now tighten the (5) bolts in the Keyhole slots which will secure the Firebox to the Grill.

# Assembly

## Step 16

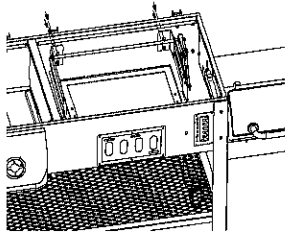

Fig. 16A

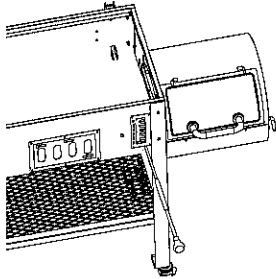

Fig. 16B

Inside Cabinet

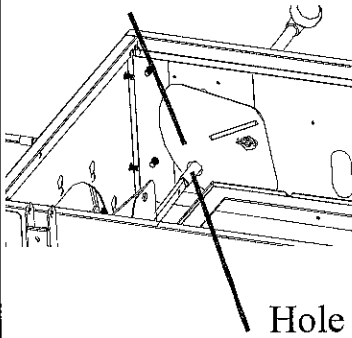

Fig. 16C

Hole

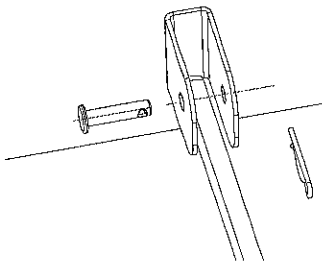

Fig. 16D

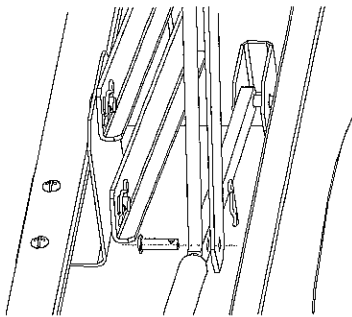

Fig. 16E

## Step 16: Installing the Charcoal Tray Lifting System

*Locate:* Charcoal Tray Lift System Lift Handle, (2) Short Hinge Pins and (2) "R" Clips and (4) M6X15 bolts .

*Procedure:*

Refer to Fig.16A.Using (4)M6X15 bolts to fix the Charcoal Tray Lifting System.

Refer to Figs. 16B and 16C and Slide the Lift Handle through the adjusting slot and through the hole of the inside plate. Align the hole in the end of the Lift Handle with the holes in the "U" shaped bracket located at the back of the Cabinet. Join the Lift Handle and the "U" shaped Bracket by inserting a Hinge pin as shown in Fig. 16D.

Then insert an "R" Clip through the hole in the short Hinge Pin. Attach the Lift Handle to the Lift System by inserting a Short Hinge Pin through the "U" shaped Lift Arm and the hole in the center of the Lift Handle as shown in Fig. 16E.



# Assembly

## Step 17

Fig. 17A

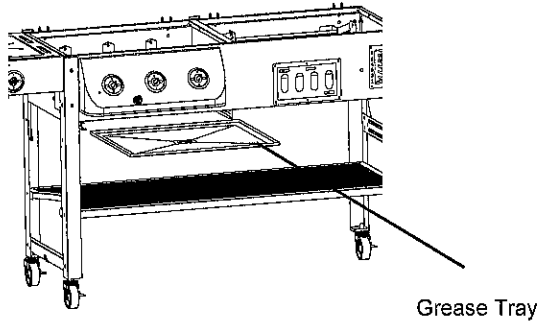

Fig. 17B

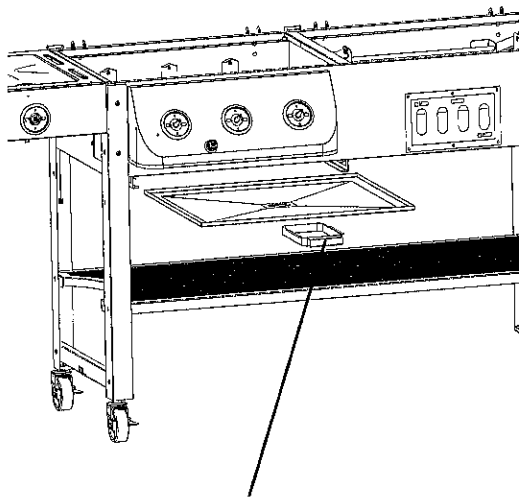
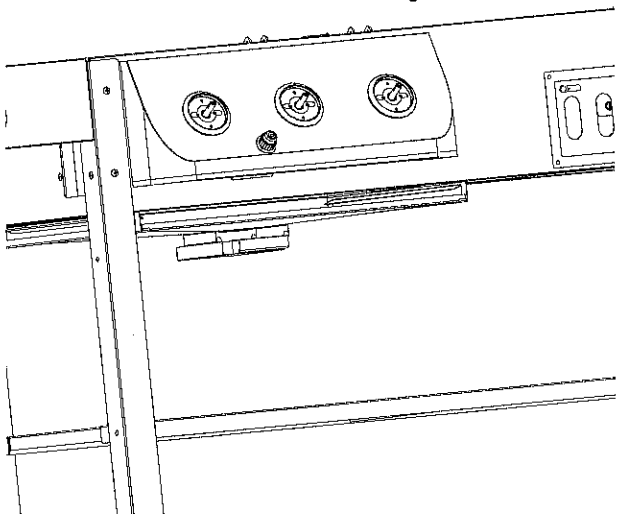

Fig. 17C



### Step 17: Assembling the Gas Grill Grease Tray and Removable Grease Cup

*Locate:* Grease Tray and Removable Grease Cup

*Procedure:*

Position the drain hole in the grease tray to be toward the front of the grill .

Refer to Figs. 17A; 17B; and 17C. Note in Fig 17C, that there are Guides for the Removable Grease Cup to slide in and out on from the FRONT of the Grill, so, the guides must open to the FRONT of the Grill! Standing at the Front of the Grill, slide the Grease Tray slightly above the Support Bracket rails in the front of the Grill. It will drop into place against the rail stops, which prevent it from sliding in or out of the Grill .

**Note: Grease Drip Trays and Grease Cup Should be emptied and cleaned after each use to prevent flare – ups and /or grease fires.**

## Step 18

Gas Grill lid

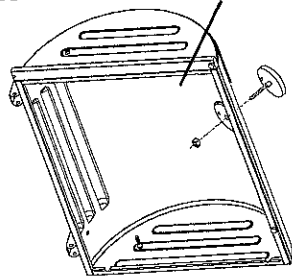

Fig. 18A

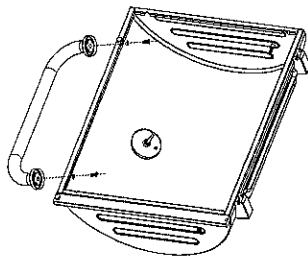

Fig. 18B

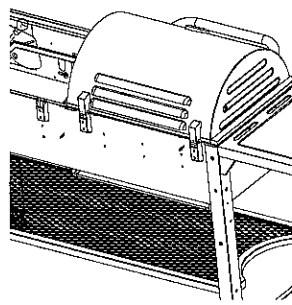

Fig. 18C

## Step 18: Assembling the Gas Grill Lid

*Locate:* The Gas Grill Lid ( it has louvers at the back), (1) Heat Indicator, (1) Lid Handle, (2) M6x15 bolts, (2) Long Hinge Pins, (2) "R" Clips

### *Procedure:*

Refer to Fig. 18A and unscrew the nut from the Heat Indicator stem. Insert the Heat Indicator through the hole in the front center of the Lid with the Dial Face outside. Secure it to the Lid with the nut you removed – check to see the dial face is correctly aligned , then tighten the nut with wrench.

Refer to Fig.18B and attach the Lid handle to the Lid with (2) M6x15 bolts as shown.

Refer to Fig.18C and place the Lid on the Gas Grill side of the Grill. Attach the Hinges together using the (2) Long Hinge Pins and insert an "R" Clip into the ends of the Pins to keep them from coming loose.

**NOTE:** The lid and cabinet hinges can be adjusted to ensure proper alignment of the grill lids. In order to adjust lid alignment , loosen all hinge bolts, close and align the lids, and then tighten the lower hinges on the grill body, followed by the upper hinges on the grill lids. The lower hinge bolts are at the back of the grill body and the upper hinge bolts are inside the grill lids.

## Step 19

Fig. 19

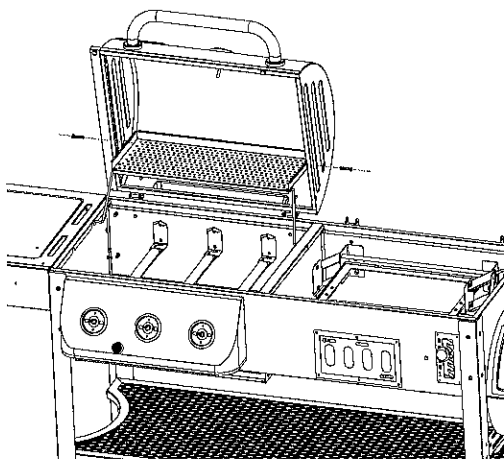

## Step 19: Attach the Warming Rack on the Gas Grill Side

*Locate:* Warming Rack, (2) M6x30 Bolts

### *Procedure:*

Refer to Fig. 19 and attach the back of the Warming Rack to the Lid with (2) M6x30 bolts as shown. Insert the Front Wire Legs into the holes on each side of the Grill. Open and close the Lid to be

# Assembly

## Step 20

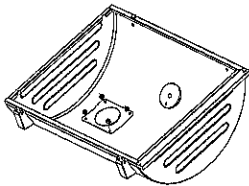

Fig. 20A

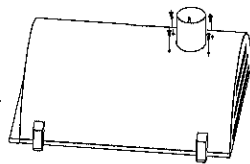

Fig. 20B

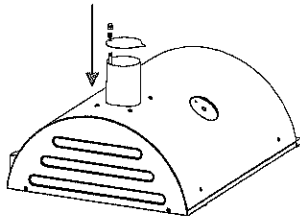

Fig. 20C

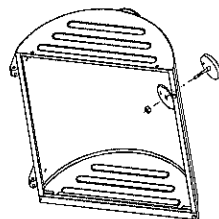

Fig. 20D

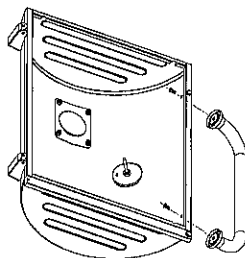

Fig. 20E

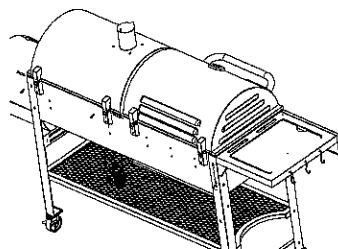

Fig. 20F

## Step 20: Assemble Smoke Stack and Charcoal Grill Lid

*Locate:* Smoke Stack Assembly, Smoke Stack Lid, (6) M6x15 bolts, (4) M6 KEPS nuts, (1) small spring, (1) M6 Cap nut, (1) Heat Indicator, (1) Lid handle, (2) Long Hinge Pins, (2) "R" Clips

### *Procedure:*

Refer to Fig. 20A and 20B Insert the Smoke Stack Assembly from **INSIDE** the Lid and fasten it to the Lid with (4) M6x15 bolts and KEPS nuts. **NOTE:** the bolts are inserted from the **OUTSIDE** of the Lid.

Refer to Fig. 20C and Place the Smoke Stack Lid onto the threaded stud, add the small spring and then fasten with the Cap nut tight enough that the Lid can be rotated to open and close the Smoke Stack.

Refer to Fig 20D and unscrew the nut from the stem of the Heat Indicator and follow the same procedure as before to install it to the Charcoal Grill Lid.

Refer to Fig. 20E and attach the Lid Handle to the Lid with (2) M6x15 bolts.

Refer to Fig. 20F and attach the Lid to the Charcoal Grill Side, following the same procedure as before on the Gas side.

**Note:** The lid with smoke grill side must be attached to the charcoal grill side.

## Step: 21 Attach the Damper Control Knob.

*Locate:* Damper Control Knob.

Screw the Damper Control Knob into the slotted hole of the Damper Plate. Check to see that the plate will slide back and forth easily.

## Step 21

Fig.21

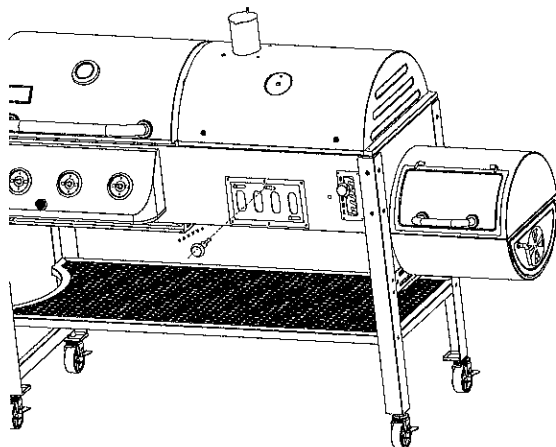

# Assembly

## Step 22

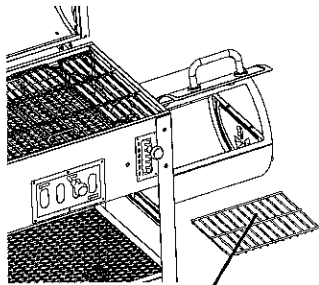
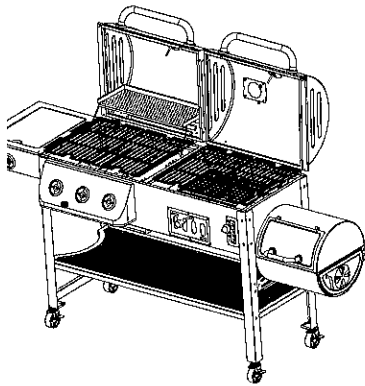
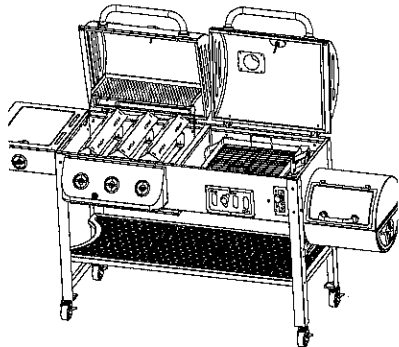
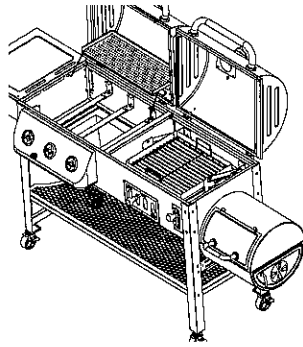

Firebox wood rack

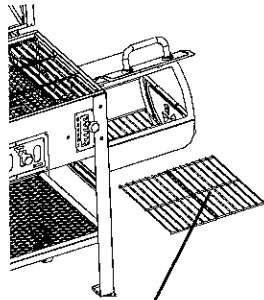

Firebox Cooking grids

## Step 22: Final Preparation.

*Locate:* (4) Cooking Grids ,Charcoal Basket ,  
(3) Heat Tents, Firebox Cooking Grid and  
Wood Rack.

*Procedure:* Refer to figures and place all the  
respective components into the Position in the  
grill.

# Assembly

## Step 23

Fig. 23A

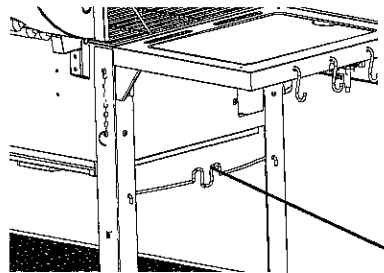
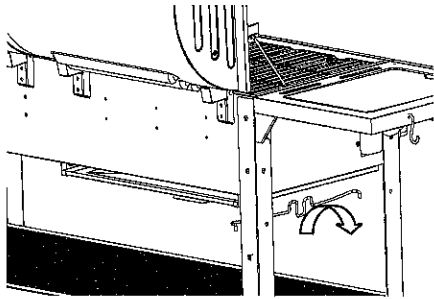

Retaining Wire

Fig. 23B

## Step 23: Attach the LP Gas Cylinder Wire Retainer

*Locate:* LP Gas Cylinder Wire Retainer

### *Procedure:*

Attach retaining wire to legs at left end of grill as shown in Figure 23B. Position the retaining wire inside the legs and under the grill body with the curved side up. Then insert the ends of the wire through the holes in the legs and rotate the wire toward you.

## Step 24

Fig. 24A

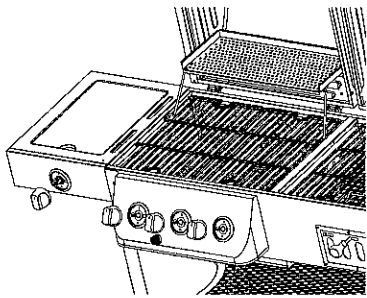

Fig. 24B

## Step 24: Installing the Igniter Battery and (4) Control Knobs on Control Panels.

*Locate:* The AA battery can be found on the Hardware Blister Card, (3) Control Knobs and (1) Control Knob for Side Burner Control Panel

### *Procedure:*

Put (3) Control Knobs on Gas grill Control Panel and (1) Control Knob on the Side Burner Control Panel one by one showing as Fig.24A

Refer to Fig. 24 – unscrew the black cap from the Electronic Igniter. Insert the AA battery with the + end facing out. Screw the black cap back onto the Igniter. When you press the soft black button on the cap, you should see small sparks jumping from the electrodes onto all the Burner Tubes and the Sear Burner. The Igniter will light ALL the burners when you open the gas control valves and press it.

## Step 25

Fig. 25

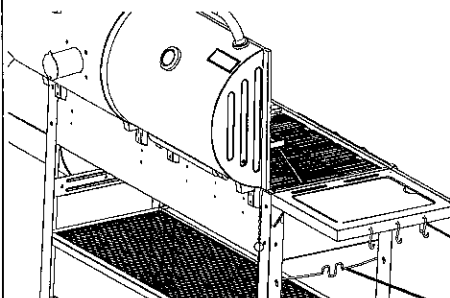

Retaining Wire

## Step 25: Attach Match Holder and Chain

*Locate:* Match Holder and Chain

### *Procedure:*

Attach Match Holder and Chain to the top Rear hole in the left REAR LEG by using the M6x15 bolt (already installed in Step 2) through the loop of the chain and securely tightening, see Fig. 25.

# Assembly

Step 25

Completed Grill



Assembly of your grill & smoker is now complete.

To order a cover for your grill, please visit: [www.thesmokercompany.com](http://www.thesmokercompany.com)

**FOR YOUR SAFETY, FOLLOW ALL SAFEGUARDS AND INSTRUCTIONS**

## OPERATING INSTRUCTIONS

### Connecting the LP gas cylinder to the grill

- The LP Gas Cylinder must be a 20 pound cylinder and have a Type 1 Cylinder Valve Outlet Connector.
- Handle the Cylinder with care - do not drop it.
- When you are not using the grill, the LP Gas Cylinder should be disconnected.
- Connect the regulator and hand tighten firmly.
- Do a leak test each time you connect a LP Gas Cylinder and before lighting the grill.
- Never use a match or lit flame to test for leaks.
- To test, prepare a weak solution of detergent and water. Spray or swab the solution onto the connection of the regulator to the LP Gas Cylinder valve, and on all the joints in the hose connections up to the burner valves (which **MUST** be closed in the "OFF" position).
- Open the LP Gas Cylinder valve, and watch for any bubbles to appear at all the connection points. No bubbles indicate - All Clear!
- If there are any bubbles, there is a leak which must be fixed.
- Never obstruct the flow of combustion and ventilation air.

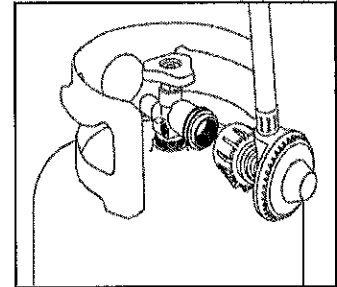

### Lighting the grill

- Always open the Lid before lighting the grill.
- All burner knobs should be in the "OFF" position.
- Slowly Open the LP Gas Cylinder valve, 1-1 1/2 turns
- Push the knob in fully, and slowly turn it counter-clockwise (to the left) to the "LIGHT" position.
- Then press and hold the black button of the igniter, there will be clicking and sparking until the burner is lit.
- You can then adjust the knob to your desired setting.
- If the burner did not light, turn the knob back to the "OFF" position, wait 5 minutes for any gas to clear away, and then repeat the lighting procedure.
- For Side Burner, turn the knob counter-clockwise (to the left) and then PUSH the Black Igniter Button to light the burner. If the burner does not light, then turn the knob to the "OFF" position, wait 5 minutes and then try again.
- After using the grill, - turn all burner knobs to the "HIGH" position and then push fully in and turn to the "OFF" position.
- At once turn the valve on the LP Gas Cylinder OFF.
- IF the igniter does NOT light the burner, you can light it with a match or a piece of burning paper - hold the match or paper with the Match Holder attached at the back of the grill, put it through the openings in the Cooking Grid and next to the Flame Tent covering the burner. Then follow the lighting procedure above.
- Observe the proper burner flame - it should be a blue/yellow color about 1/2" long.

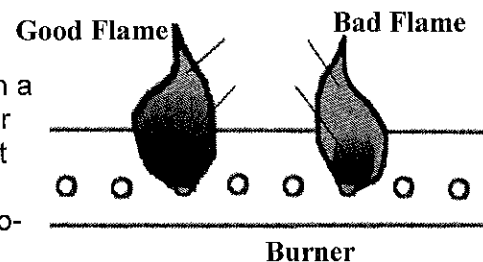

## OPERATING INSTRUCTIONS

### CARE AND CLEANING

#### ! WARNING !

- Do not do any cleaning or maintenance on any grill parts until all parts are cool! Be sure that the valve on the LP Gas Cylinder is closed and in the OFF position
- After every cooking session, you may run the gas grill on HIGH, or set the Charcoal Coals into the HIGH position to burn off any food residue, keeping the residue from building up.

#### CLEANING

- Use only mild dishwashing detergents, hot water, a nylon scrub pad and a BBQ wire brush cleaning tool
- Always rinse all surfaces thoroughly after cleaning
- Handle Porcelain coated surfaces gently and carefully- they are made from high temperature glass and can chip easily
- **Note: Grease Drip Trays and Grease Cup should be emptied and cleaned after each use to prevent flare – ups and /or grease fires.**

#### Burners

1. Turn the gas OFF at the LP Gas Cylinder and the burner control knobs
2. Lift off the cooking grids and the heat tents covering the burners
3. Remove the screw attaching the burners at the back of the grill
4. Gently and carefully, tilt the back of the Burner up and slide it backwards off the valve orifice, then lift out of the grill
5. Wipe clean the orifice face

### TROUBLE SHOOTING THE GAS GRILL

#### Burner does not light :

1. Check if LP Gas Cylinder is empty?
2. Check Igniter wire – is there a spark?
3. Check for spider webs or insect nests inside, clogging the Burner

#### Flame color is Yellow, should be Blue:

1. Check for spider webs or insect nests inside, clogging the Burner
2. Close Lid and run on HIGH to burn off residue on Burner

#### Flame flares up:

1. Cooking temperature is set too high
2. Food being cooked is too fatty
3. Grease has accumulated in the grill. Clean and burn off



## OPERATING INSTRUCTIONS

### ! IMPORTANT ! CURING PROCESS

#### LP GAS GRILL

Step 1: Lightly coat ALL INTERIOR surfaces (including interior of lids, cooking grids and area below the cooking surface) with vegetable oil or vegetable oil spray.

Step 2: Ignite the LP gas grill side and burn at medium temperature for one hour.

Step 3: Let the grill cool completely and it is ready for use.

#### CHARCOAL GRILL & FIREBOX

Step 1: Lightly coat ALL INTERIOR surfaces (including interior of lids, cooking grids and area below the cooking surface) with vegetable oil or vegetable oil spray.

Step 2: Start a charcoal fire using 1-2 lbs of briquette or lump charcoal. Keeping the lids open until the flames have burned down.

Step 3: After flames have burned down close lids and all dampers and maintain fire at 300 to 400 degrees Fahrenheit for one hour.

Step 4: Let the fire burn out and grill cool completely before use.

### CHARCOAL GRILL OPERATING INSTRUCTION

The charcoal offset Fire Box Grill & Smoker can be used to cook food either by:

**CHARCOAL AND DIRECT HEAT –OR– SMOKE AND INDIRECT HEAT**

Please read all steps before cooking.

### TO COOK USING CHARCOAL AND DIRECT HEAT

(The fire is in the Charcoal Cooking Chamber and the food is in the Charcoal Cooking Chamber.) Follow these steps for cooking with charcoal and direct heat in the Charcoal Cooking Chamber.

1. For best results use a metal charcoal starter and fill the starter with about 3 lbs of charcoal and light the charcoal.
2. After 30 minutes, dump the charcoal into the bottom of the Smoker Chamber on the charcoal grates, which should be at the lowest adjustment.
3. Adjust the Fire Box and Smoker Chamber dampers to 1/4 to 1/3 open.
4. Immediately and carefully place another 3 lbs of charcoal on top of the burning coals in the Smoker Chamber.
5. Once the temperature reaches your desired level, food can be placed on the cooking grates.



*The adjustable charcoal grate in the Smoker Chamber allows the charcoal grate to be moved to within a few inches of the cooking grate allowing you to sear your meat and lock in the juices. Searing takes only a few minutes on each side. Don't allow the meat or food to burn. After searing, crank the charcoal grate back to the bottom and cook the food to your personal preference.*



*For smaller cookouts, the Fire Box can be used instead of the larger Smoker Chamber for cooking with charcoal and direct heat. Follow the same steps above for cooking in the main Smoker Chamber.*

FOR YOUR SAFETY, FOLLOW ALL SAFEGUARDS AND INSTRUCTIONS.

## OPERATING INSTRUCTIONS

### TO COOK USING SMOKE AND INDIRECT HEAT

 (The fire is in the Fire Box and the food is cooked or smoked in the Smoker/Cooking Chamber. The smoke and the indirect heat pass through the opening between the Fire Box and Smoker/Cooking Chamber. Follow the steps below for smoking and/or cooking . Note that the indirect cooking or smoking process will take longer than traditional barbecuing. At 225 to 250 degrees, it will take approximately 30 minutes per pound of meat.)

- 1 Fully open Smoke Stack and damper on Firebox Door.
- 2 Place 2-3 pounds of charcoal on Firebox charcoal grate. Light charcoal and allow it to burn until coals are glowing. Add your desired flavoring, Wood (hickory, mesquite, pecan, apple, alder, etc.) to the charcoal.
- 3 For indirect cooking, we recommend 225-250°F. For smoking, the desired temperature may be lower.  
The heat and smoke can be regulated by adding more charcoal/wood and by opening or closing the damper / smoke stack .
4. Once the desired temperature is achieved, place the food in the cooking chamber. Continue to monitor the temperature as the food smokes/cooks. For the best heat and smoke flow, open the smoke stack and close the Fire Box damper. Keep the charcoal damper on the front of the grill closed when smoking/indirect cooking. At 225 to 250 degrees, it will take approximately 30 minutes per pound to cook the food. Time will vary depending on the temperature at which food is smoked/cooked. The level of desired doneness will also affect the cooking time.
5. For best results, try to maintain a constant temperature inside the cooking chamber by adding charcoal wood as necessary and adjusting the damper openings. Check the internal food temperature periodically by inserting a meat thermometer into the Food. Use caution when checking the food temperature to avoid injury.
6. Once the food has reached the desired temperature, remove from cooking chamber and let stand 30 minutes. The USDA Standard temperature chart for properly cooked meat can be found at the back of this manual.

FOR YOUR SAFETY, FOLLOW ALL SAFEGUARDS AND INSTRUCTIONS.

## **Operation: Smoking food**

### **Rules for smoking:**

We recommend that most smoking be done at 225 to 250 degrees. We also recommend the use of an oven thermometer to verify the inside temperature of your smoker and a meat thermometer to check the temperature of the meat. The heat indicator will give you an indication of the temperature inside the smoker but it is best to use an oven thermometer to ensure that the temperature is correct. A good rule of thumb for smoking is to cook the meat for 30 to 45 minutes per pound. As the weight of the meat increases so will the amount of time needed. For instance, 2 or 3 pounds of meat might take 30 minutes per pound or while 7 or 8 pound will require closer to 45 minutes per pound. Refer to the temperature chart in the Assembly Manual to make sure that the meat is at an acceptable temperature.

### **Types of wood to use for smoke:**

1. What type of hardwood should you use?  
Always use a hardwood that has been seasoned for at least 6 months.
2. Can I use Oak pallets?  
NO, because pallet wood is dried out before it is used for making pallets. You need the natural moisture in wood to create flavor in your smoke.
3. Can I use Pine, Cedar or any other wood that smells good?  
NO, never use any resin woods.

### **What are the main items I need to smoke meats?**

1. Internal meat thermometer .  
An internal meat thermometer is a must to cook large pieces of meat to make sure it is done internally.  
Cooked Ham-140 degrees  
Ham, Beef-Med, Ground Beef- 160 degrees  
Veal, Lamb, Pork, Beef-Well done – 170 degrees  
Poultry- 180 degrees
2. Good tongs or meat hook.  
Use a heavy-duty set of tongs to rotate meat in the smoker because in some cases you may be smoking a very large cut of meat. I prefer a meat hook for ease of use and it does not knock any rub or sauce off of the meat.
3. Good oven mitts.  
Heavy-duty mitts will assist you in moving hot smoker racks and large pieces of meats and assist in adding water and wood chips.
4. Aluminum foil.  
When the outside color of your meat product is at your desired color or look to suit your taste, wrap meat product in aluminum foil to keep any more wood resins from turning your meat any darker.

## **Operation: Smoking food**

### **Classic Recipes:**

#### **Pork**

##### ***Smoked Pork Tenderloin***

Take outside wrapper off of meat and wash thoroughly in cold water. Place tenderloin on a paper towel to soak up excess water. Rub your favorite pork rub on the loin (we recommend Head Country Pork seasoning). Preheat smokers to 225 degrees and place loin in the center of the smoker. Cook until internal meat temperature reaches 165 degrees. Take out of smoker and let stand on the cutting platter until meat reaches 170 degrees serving temperature. Slice like bread in 1/4" pieces and it will melt in your mouth.

##### ***Pork Ribs- Baby Backs or Spare Ribs***

Take ribs out of wrapper and drain all liquid off of the ribs and then wash in cold water. Place on cutting board and cut away any excess fat or skin from the bottom of ribs. Turn ribs with bone side up and peel the membrane from the back of the bone until all is gone. Rub your favorite pork rub on both sides of the ribs (we recommend Head Country Pork seasoning). Preheat smoker until it reaches 225 degrees and place rib bone side down in smoker. After one hour, turn the rib over with bone side up and cook for one hour. After 2 1/2 hours, depending on the color of the rib you like, pour a one-inch wide strip of your favorite BBQ sauce down the length of the rib and wrap tightly in aluminum foil. Place back in smoker and check every 15 to 20 minutes to see if the rib bones separate by using your finger to pull them apart. If they pull apart with ease your ribs are done. Take out of smoker and let stand on serving platter until cool enough to eat. Total cooking time should not be more than 3 1/2 hours total.

#### **Beef**

##### ***Smoked Beef Brisket***

Select a 6 to 8 lb. packer trimmed brisket that has a little marble to it but not too much. Feel free to trim as much fat as desired. Use your favorite beef rub (we recommend using Head Country All-Purpose rub) and rub it on liberally. Heat the smoker to 225 degrees and place the brisket in the smoker for 3 hours. Place brisket in an aluminum foil pan and pour approximately 8oz. Of Allegro over the brisket. Cover the pan tightly with aluminum foil and continue cooking until internal meat temperature reaches 165 to 170 degrees. Take pan out of the smoker and let brisket stand. Remove brisket from pan and cut 1/4" slices against the grain. Use juice from pan to pour over sliced meat or for dipping.

##### ***Prime Rib***

Select a 6 to 8 lb prime rib (we like the bone on). Rub the prime rib with your favorite beef rub (we recommend using Head Country All-Purpose rub). Pre-heat the smoker to 225 degrees and place the prime rib in the smoker. After 3 hours, place the prime rib in aluminum foil pan and cover with aluminum foil. When internal meat temperature reaches 145 degrees take out of smoker and let stand until your desired doneness is reached. Medium rare is 155 to 160 degrees. While standing, the temperature of the meat will rise internally up to 10 degrees. Slice prime rib to desired thickness and serve with juice from the pan in which it was cooked.

## **Operation: Smoking food**

Classic Recipes:  
(Continued)

### **Fish**

#### ***Smoked Halibut***

Select a nice fresh 3/4" thick filet. Wash filet thoroughly in cold water and lay on paper towel until water is not visible. Melt a whole stick of butter in the microwave and sprinkle a liberal amount of Dill weed in the melted butter. Lay filets on Aluminum foil and fold a lip around edges to contain the butter. With a basting brush, brush melted butter and dill weed mixture on both sides of the fish filet. Preheat smoker to 225 degrees and place fish in the smoker. Check the filets every 15 minutes for visible moist look on filets. Brush with butter and dill weed mix when needed. Fish should start to flake in about 45 minutes. When fish flakes very easy take out of smoker and serve.

### **Poultry**

#### ***Smoked Chicken***

Chicken breasts and thighs are my favorite. Take chicken parts out of package and wash thoroughly and place on paper towel to dry. Sprinkle Head Country Original rub on both sides of chicken parts. Preheat smoker to 225 degrees and place chicken parts in smoker. After 1/2 hour turn chicken over. With your internal temperature gauge, check internal temperature by pushing temperature probe into the meat nearest the bone. When temperature reaches 180 degrees chicken is done. You may brush your favorite BBQ sauce on the chicken during the last 15 minutes of your cooking process to spice it up.

#### ***Smoked Turkey***

Select a 12 to 15 lb. turkey for best results in a smoker. Take the turkey out of the package and remove all internal parts and packaging. Wash turkey thoroughly and place it on paper towel to dry. Rub olive oil inside and out on the turkey and apply Head Country Original Rub inside body cavity and on the outside skin. Preheat smoker to 225 degrees and place turkey in smoker. You may baste with butter for more moisture, if you like. When turkey skin reaches your desired color, remove turkey from smoker, place in aluminum foil pan and cover with aluminum foil tightly. Place covered pan in smoker and continue cooking at 225 degrees. Check internal meat temperature, where the thigh meets the side of the turkey, every half hour for doneness. Turkey should take around 45 minutes per lb to reach 180 degrees serving temperature.

## Operation: Cooking

### Temperature Chart

Refer to this USDA Standard chart for properly cooked meat temperature.

**IMPORTANT:** Measure the meat temperature using a meat probe thermometer. The heat indicator on the smoker gives the heat temperature inside the smoker cabinet, but is not an accurate measurement of the meat temperature.

### Temperature on Meat Thermometer

Beef Roasts, Beef Brisket	3-4 lbs.	4-5 hours	140° rare
Lamb Roasts, Venison	5-7 lbs.	5-6 hours	160° medium
Large cuts of Game	7-9 lbs.	7-10 hours	170° well done
Pork Roasts	3-4 lbs. 5-8 lbs.	5-6 hours 7-8 hours	170° 170°
Pork/Beef Ribs	Full grill	4-6 hours	Meat pulls from bone
Pork Chops	Full grill	4-6 hours	Meat pulls from bone
Sausage Links	Full grill	4-5 hours	170° for fresh sausage
Ham, Fresh	10 lbs.	7-8 hours	170°
Ham, Cooked	All sizes	3-4 hours	130°
Chicken (Cut up or split)	1-4 fryers, cut up or split	4-5 hours	180°/leg moves easily in joint
Chicken (Whole)	1-4 fryers	5-6 hours	180°/leg moves easily in joint
Turkey (Unstuffed)	8-12 lbs.	7-8 hours	180°/leg moves easily in joint
Fish, small whole	Full grill	2-3 hours	Flakes with fork
Fish, filets, steak	Full grill	1-3 hours	Flakes with fork
Duck	3-5 lbs.	5-6 hours	180°/leg moves easily in joint
Small game birds	Full grill	4-5 hours	180°/leg moves easily in joint

## Limited Warranty



This Smoker Hollow™ Grill is guaranteed against broken or damaged parts at time of purchase. All parts carry a 1-year limited warranty. Paint is guaranteed to be free of defects for 90 days except for rust, which may appear after repeated use.

This warranty does not cover damage or issues related to neglect, abuse, or modifications to the product. Repair labor is not covered.

All parts that meet the warranty requirements will be shipped at no-charge via the discretion of the Customer Service Department (ground shipments, US Mail, or Parcel Post Only). Any special handling charges (i.e. Second Day, Overnight, etc.) will be the responsibility of the consumer.

All warranty claims apply only to the original purchaser and require a proof of purchase verifying purchase date. Do not return parts to our address without first obtaining a return authorization number from our customer service.

This service is available by calling 866-475-5180, 8:30am to 4:30pm, Central Time, Monday through Friday, or write to Outdoor Leisure Products, Inc., 5400 Doniphan Drive, Neosho, MO 64850.

This warranty may give you specific legal rights that vary by state.

Outdoor Leisure Products, Inc  
5400 Doniphan Drive  
Neosho, MO 64850  
[www.olp-inc.com](http://www.olp-inc.com)

©2013 Outdoor Leisure Products, Inc. Smoke Hollow and the Smoke Hollow logo are trademarks of Outdoor Leisure Products, Inc. and are not to be used without express permission by Outdoor Leisure Products, Inc.