

This Owner's Manual is provided and hosted by [Appliance Factory Parts](#).



Smoke Hollow PS3615 Owner's Manual

[Shop genuine replacement parts for Smoke Hollow
PS3615](#)



[Find Your Smoke Hollow Grill Parts - Select From 115 Models](#)

----- Manual continues below -----



Owner's Manual

Pellet Smoker Grill

Models PS2415 & PS3615



Model PS2415

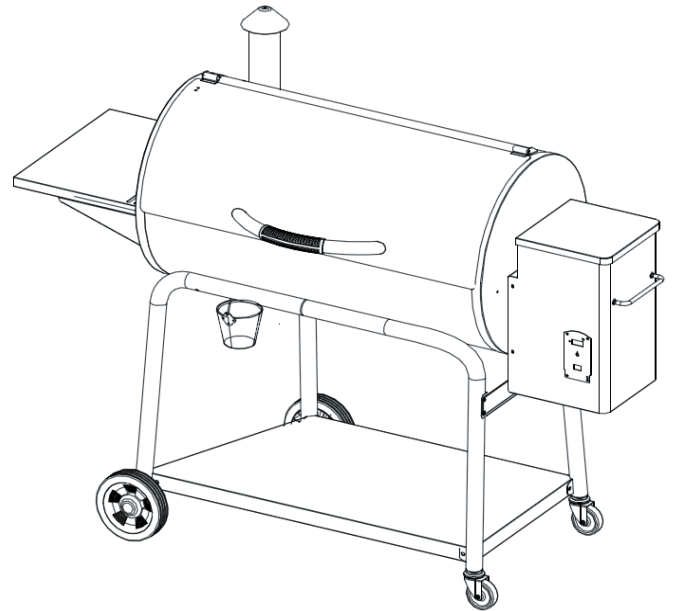

Model PS3615



FOR OUTDOOR USE ONLY

WARNING!

**DO NOT STORE OR USE COMBUSTIBLE MATERIALS NEAR THIS APPLIANCE!
USE ONLY PREMIUM 100% HARDWOOD BBQ PELLETS WITH THIS SMOKER GRILL.**

Please read this entire manual before installation and use of the pellet fuel-burning appliance. Failure to follow these instructions could result in property damage, bodily injury or even death. Contact local building or fire officials about restrictions and installation inspection requirements in your area.

SAVE THESE INSTRUCTIONS

Introduction



Congratulations on your purchase of your new Smoke Chef Pellet Smoker Grill. With proper set-up, operation and maintenance, this appliance will provide you with years of delicious food and cooking enjoyment.

IMPORTANT

When you un-pack your grill, remove all parts and packaging material from the box and inside the grill. Make sure you have all the items in the parts list. Carefully check the unit and make sure there is no damage.

IF YOU HAVE ANY PROBLEMS WITH THIS PRODUCT OR THERE ARE MISSING OR DAMAGED PARTS , PLEASE CALL CUSTOMER SERVICE TOLL FREE 1-866-475-5180 (Monday–Friday, 8:30 am–4:30 pm, CST).

NOTE : DO NOT RETURN UNIT TO THE STORE BEFORE CALLING THE TOLL FREE NUMBER. Do not dispose of your cartons until you are completely satisfied with your new pellet smoker grill.

	WARNING	
<p>CALIFORNIA PROPOSITION 65 Combustion by-products produced when using this product contain chemicals known to the State of California to cause cancer, birth defects, and other reproductive harm.</p>		

A MAJOR CAUSE OF FIRES IS FAILURE TO MAINTAIN REQUIRED CLEARANCES (AIR SPACES) TO COMBUSTIBLES MATERIALS. IT IS OF UTMOST IMPORTANCE THAT THIS PRODUCT BE INSTALLED ONLY IN ACCORDANCE WITH THESE INSTRUCTIONS.

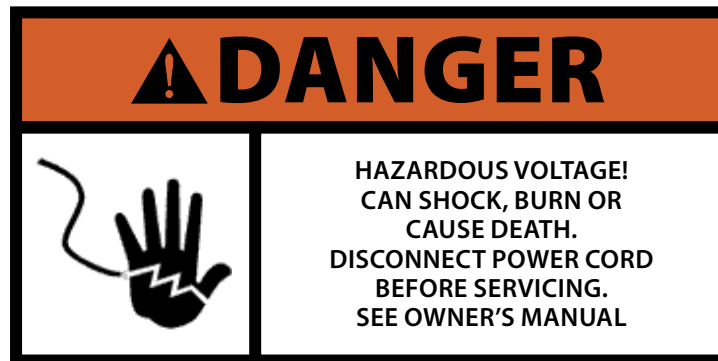

DANGER! Hazardous voltage is present which can shock, burn or cause death. Disconnect the power cord before servicing the Grill unless otherwise noted in the Owner's Manual.

DANGER! Never use or store flammable liquids near the Grill.

DANGER! Never use gasoline or lighter fluid to manually light your Grill. Use **ONLY** Alcohol Gel for this procedure **AND** according to the instructions in the Owner's Manual.

WARNING! When operating this Grill, maintain a **MINIMUM** distance of 12 inches from the Grill to combustibles.

WARNING! Do not use this appliance on floor surface that is combustible. We recommend installation on non-combustible floors or floors protected with non-combustible surfaces where the protective surface has been approved for such use by the authority having jurisdiction.

WARNING! Do not use this appliance under overhead combustible ceiling or overhang.

WARNING! Assemble and operate this Grill **ONLY** per the instructions in this Owner's Manual.

WARNING! This Grill is intended for **OUTDOOR USE ONLY**.

WARNING! Never use heating fuel pellets in the Grill, due to potential hazardous contaminants and additives that may be present.

WARNING! Use **ONLY** PREMIUM 100% HARDWOOD BBQ WOOD PELLETS, which are specifically made to work in our Grills. Smoke Hollow wood pellets are rated for 8500 BTU per LBS with an ash content of 2%.

CAUTION! Always store wood pellets in a dry location, away from heat-producing appliances and other fuel containers.

CAUTION! Keep the Grill clean - See the cleaning instructions in this Owner's Manual.

CAUTION! Do not use accessories not specified for use with this Grill.

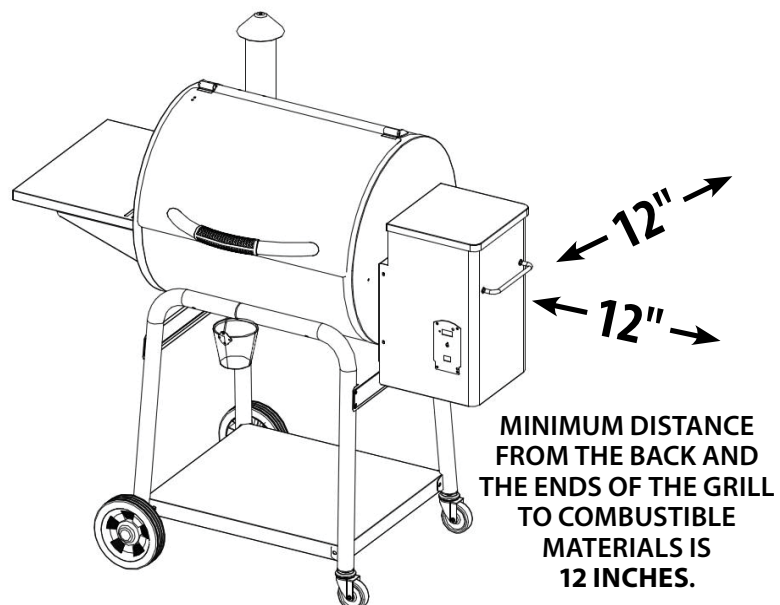

Parts and Tool List

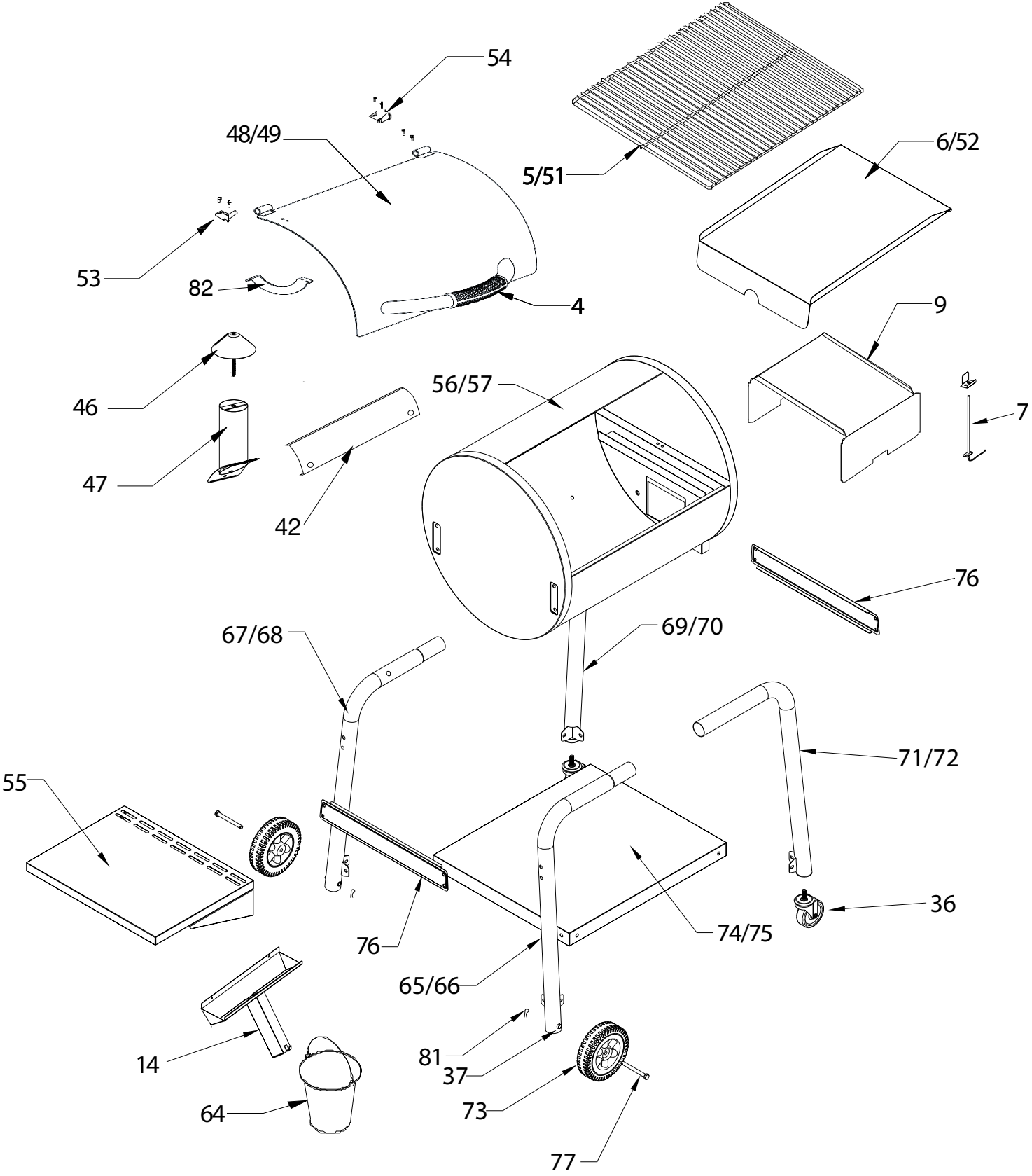

Hopper / Burner Assembly Components

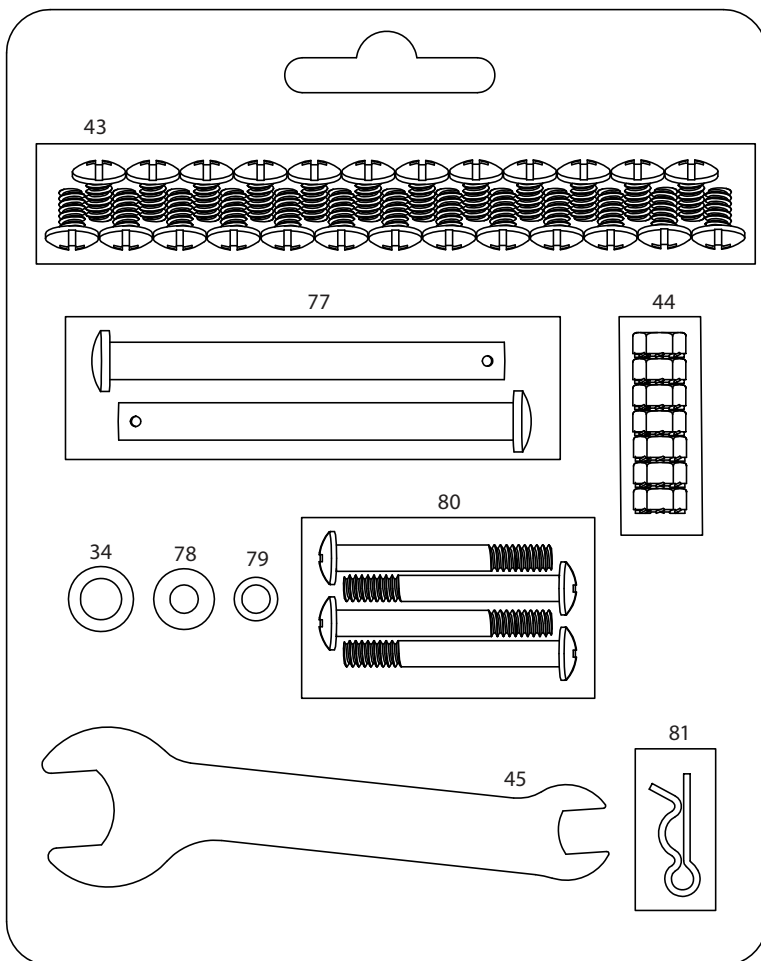
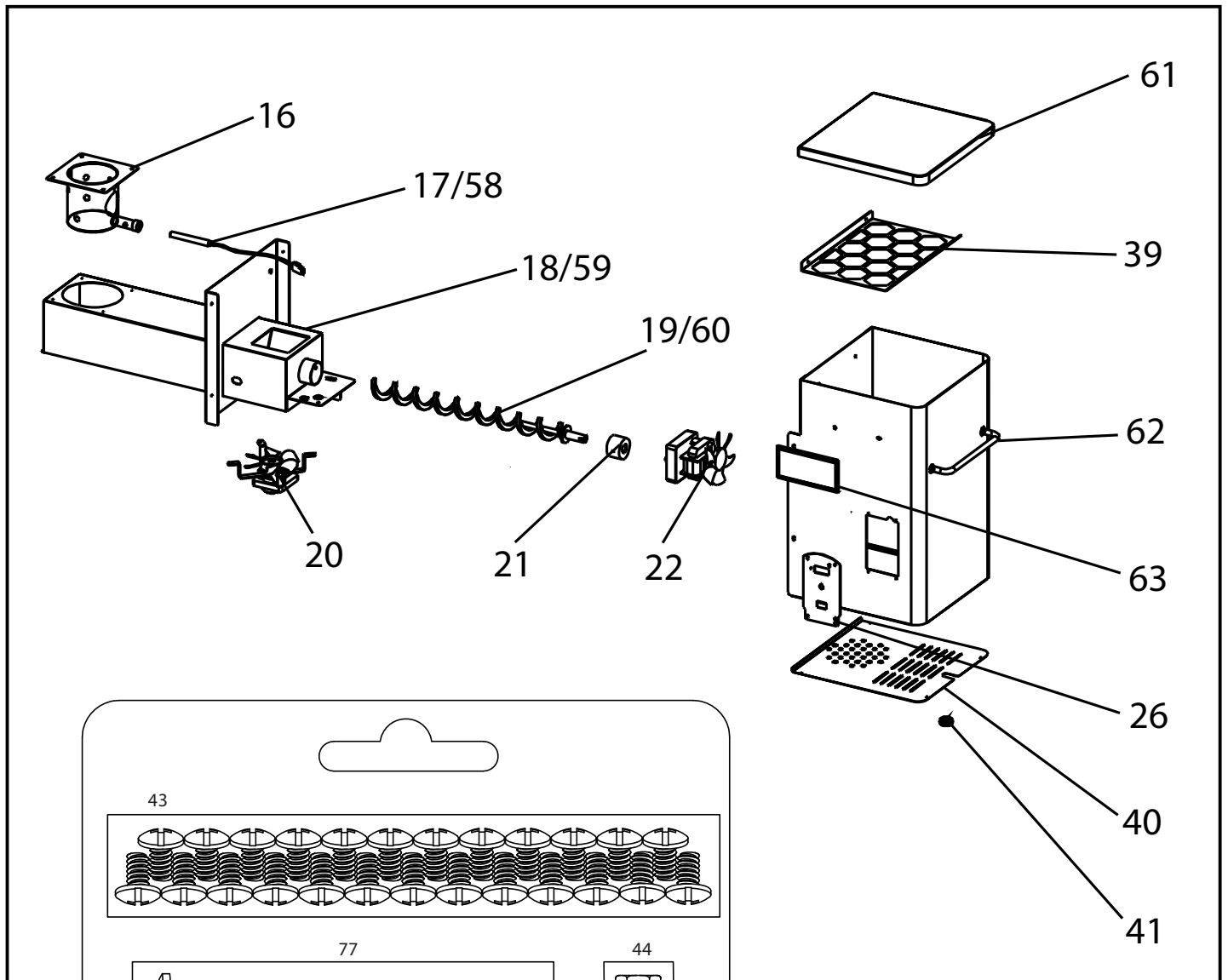

Hardware Kit Components

Parts and Tool List

Note: For assistance, including missing or damaged parts, call toll free 1- 866-475-5180 from 8:30 am - 4:30 pm Central Time, Monday - Friday

Part#		Part Name	Qty.
PS2415	PS3615		
46	46	Smoke Stack Cap	1
47	47	Smoke Stack	1
48	49	Lid	1
4	4	Lid Handle	1
5		Cooking Grid	1
	51	Cooking Grid	2
6	52	Grease Pan	1
7	7	Temperature sensor Rod Bracket	1
7	7	Temperature sensor Rod	1
9	9	Heat Baffle	1
53	53	Lid Hinge Left	1
54	54	Lid Hinge Right	1
55	55	Side Table	1
14	14	Grease tray Drain Tube	1
56	57	Grill Body	1
16	16	Firepot	1
17	58	Autostart Hot Rod	1
18	59	Auger Housing	1
19	60	Auger	1
20	20	Draft Inducer Fan	1
21	21	Nylon Retainer	1
22	22	Auger Drive Motor	1
61	61	Hopper Lid	1
62	62	Hopper with Handle	1
63	63	Name Plate	1
26	26	Controller Assembly	1
64	64	Grease Bucket	1
65	66	Left Front Leg	1
67	68	Left Rear Leg	1
69	70	Right Rear Leg	1
71	72	Right Front Leg	1

Part#		Part Name	Qty.
PS2415	PS3615		
34	34	Axle Washer	2
73	73	Wheel	2
36	36	Locking Caster	2
74	75	Lower Shelf	1
39	39	Auger Safety Screen	1
40	40	Wire Protecting Panel	1
41	41	Rubber Ring	1
42	42	Heat Shield - Lid	1
43	43	1/4--20x.59" Bolt	25
44	44	1/4x20 Nut	7
45	45	Wrench	1
76	76	Leg Support Brackets	2
77	77	Wheel Axle Pins	2
78	78	1/4 Flat Washer	6
79	79	1/4 Spring Washer	6
80	80	1/4 Bolts	4
81	81	Axle "R" Clips	2
82	82	Lid Stop Bracket	1

Grill Assembly

Step 1: Leg Assembly

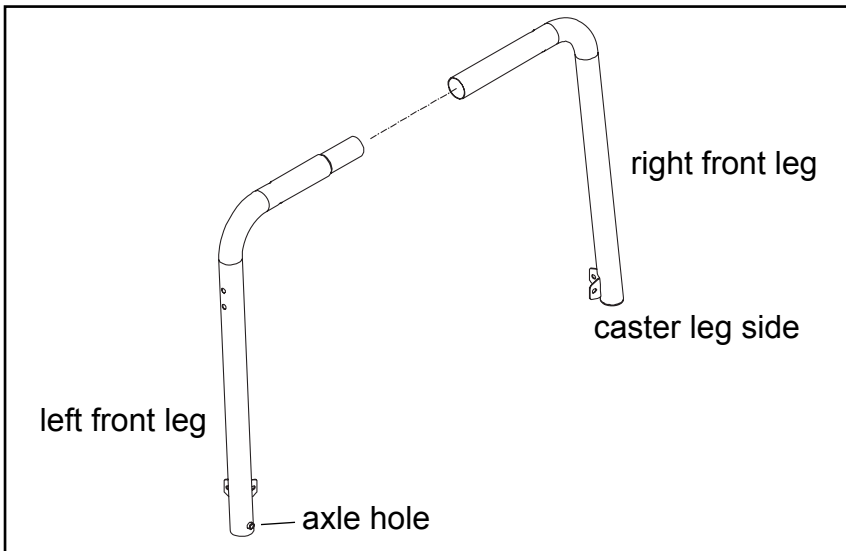

Locate:

- Left front leg
- Left rear leg
- Right front leg
- Right rear leg

Procedure:

Insert left front leg into right front leg as shown here. Insert left rear leg into right rear leg in the same manner.

Note:

The brackets on the lower part of each pair of legs should face the same side.

Step 2: Attach Legs to the Bottom Shelf

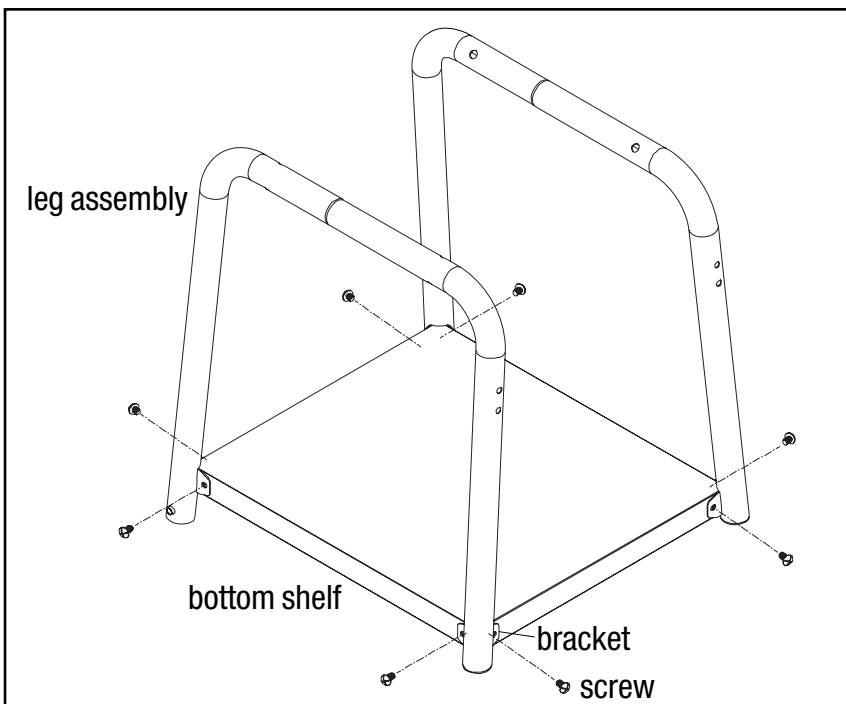

Locate:

- Bottom Shelf
- (8) 1/4-20 x .59 Bolts

Procedure:

Align the holes in the brackets of the caster legs and wheel legs with the holes in the bottom shelf. Insert the 1/4-20 x .59 Bolts through the holes in each leg bracket, then through the holes in the bottom shelf. Leave the screws loose for now.

Step 3: Attach Side Bars to the Legs

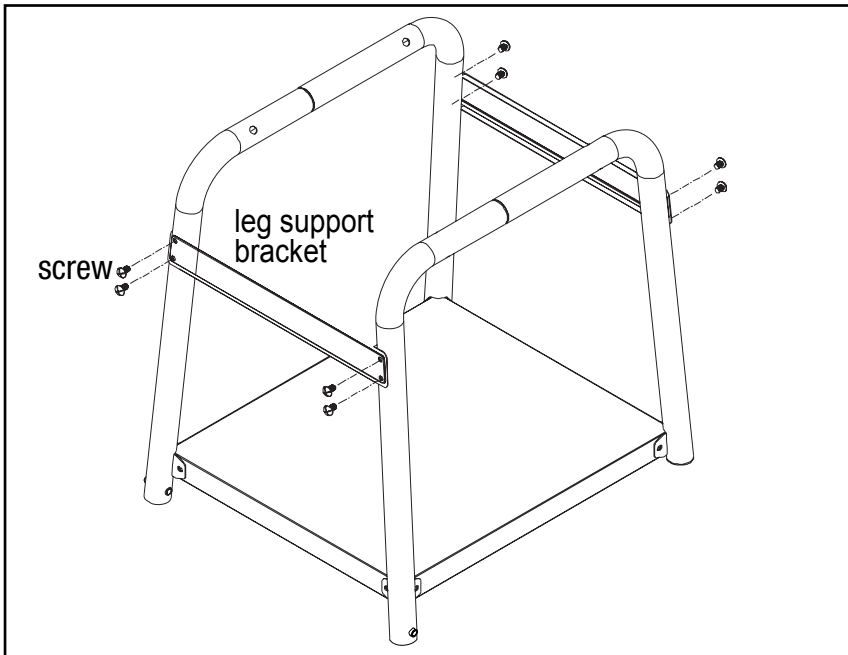

Locate:

- (2) Leg Support Brackets
- (8) 1/4-20 x .59 Bolts

Procedure:

Align the four holes in each side bar with the holes near the top of each leg assembly. Insert a 1/4-20 x .59 Bolt through each hole in the side bar, then through the corresponding hole in the leg assembly. Leave the screws loose for now.

Step 4: Attach Wheels and Casters to the Legs

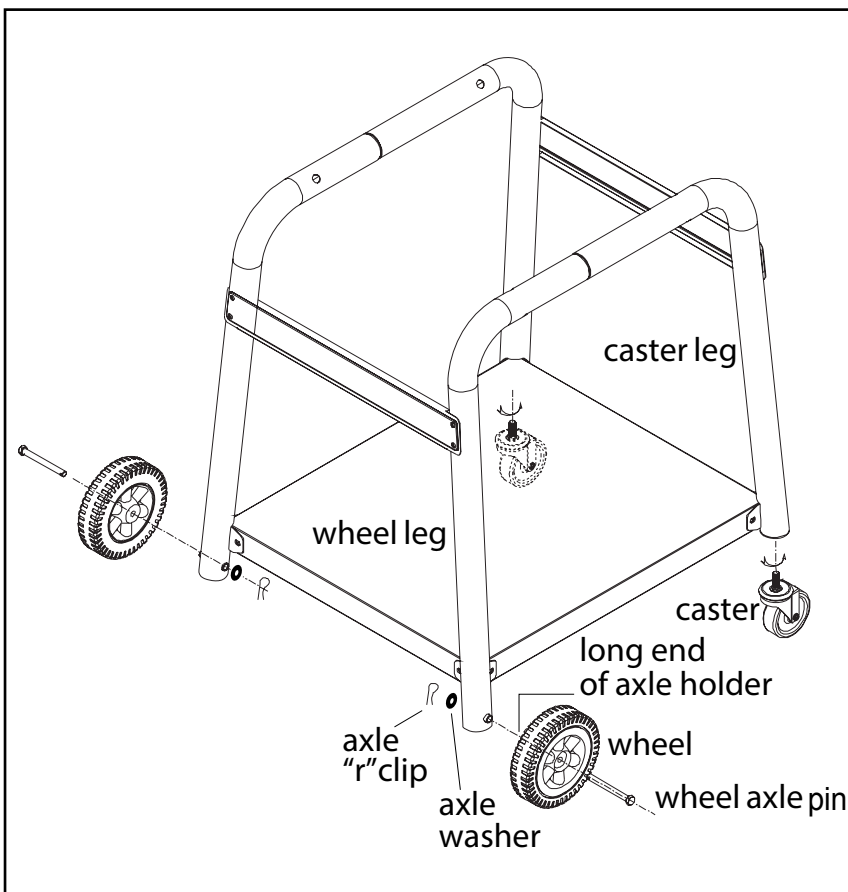

Locate:

- (2) Casters
- (2) Wheels
- (2) Wheel Axle Pins
- (2) Axle Washers
- (2) Axle "R" Clips

Procedure:

Before mounting, note that one end of the axle holder in the center of each wheel is longer than the other. With the long end of the axle holder towards the inside, insert a wheel axle pin through each wheel and wheel leg. Put an axle washer on the other side, then insert the axle "R" clip through the hole in the wheel axle pin.

Turn over the assembled legs/bottom shelf, then use the provided open end wrench to mount a caster on each caster leg by clockwise turning the hex nut on the caster into the threaded hole at the bottom of the leg tube.

Set the assembled legs/bottom shelf upright, then hold and slightly press the legs downwards to ensure all the wheels and casters land on floor. Tighten all the bolts.

Step 5: Mount the Legs on the Grill

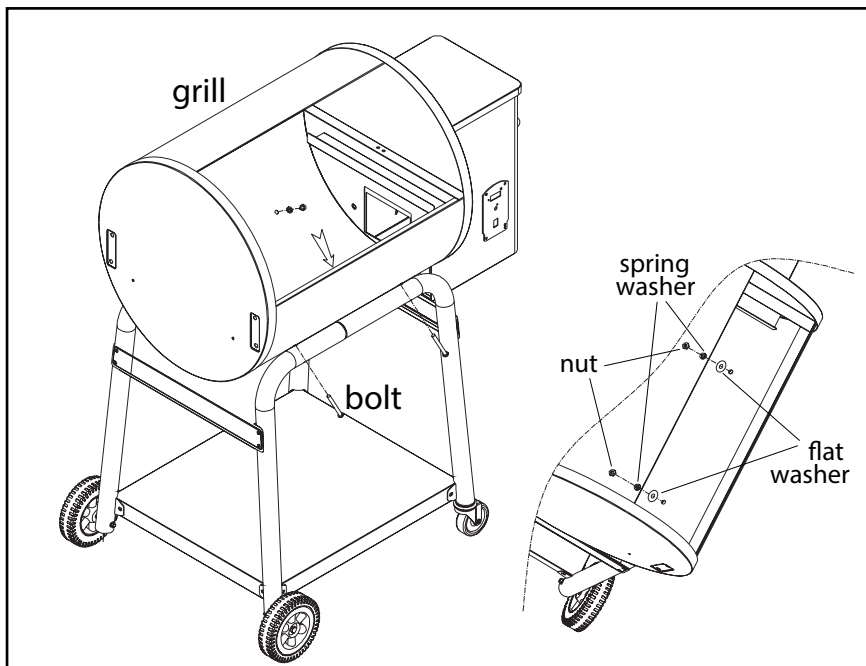

Locate:

- (4) Nuts 1/4
- (4) Flat Washers
- (4) Spring Washers
- (4) 1/4" Bolts

Procedure:

Take the porcelain grill and grease drain pan out of the grill, if you haven't already done so. Place the grill on the legs. NOTE: The two wheel legs should be located on the opposite side of the Pellet Hopper as shown. After aligning the holes in the grill and the legs, insert a 1/4" bolt through each leg tube, then through the grill. Put a 1/4" flat washer and a 1/4" spring washer on each bolt inside the grill, then put on a 1/4" nut and tighten it.

Step 6: Attach the Side Shelf Assembly to the Grill

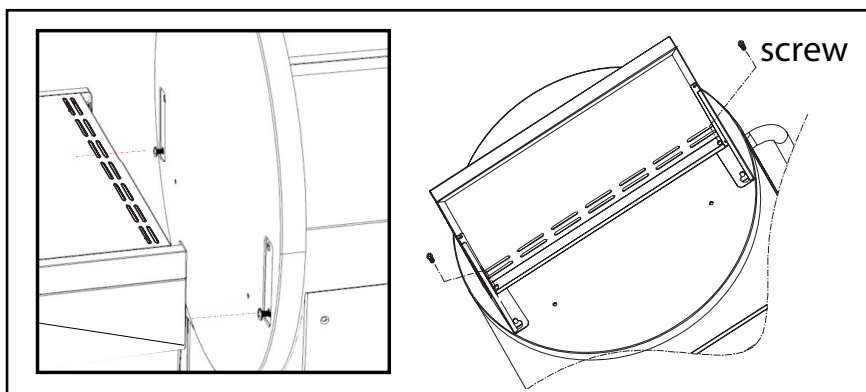

Locate:

- (4) 1/4-20 x .59 Bolts

Procedure:

Screw (2) 1/4-20 x .59" bolts into the lower holes on the left side of the barrel (leave the screws out approx. 1/4"). Set the side table onto the (2) bolts using the lower key holes. Screw (2) 1/4-20 x .59" bolts from outside of the barrel into the top holes in the side table. Tighten all (4) bolts.

Step 7: Attach the Lid Handle to the Lid

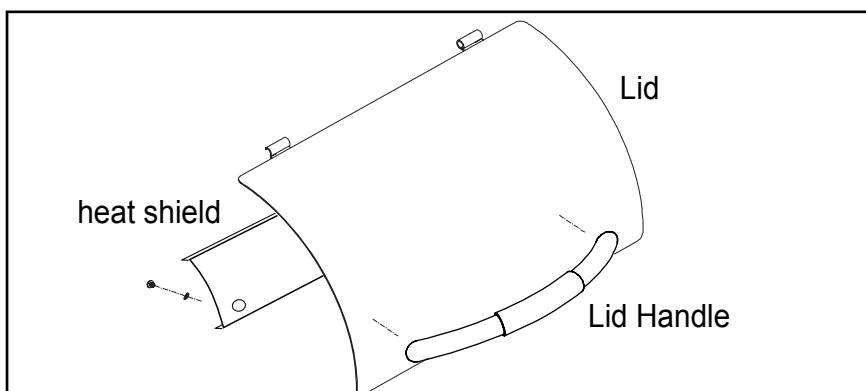

Locate:

- (1) Lid Handle
- (1) Lid
- (1) Heat Shield
- (2) 1/4-20 x .59 Bolt
- (2) Flat Washers
- (2) Spring Washers

Procedure:

Align the two holes in the lid handle with the two holes in the lid. Put a 1/4" spring washer and a 1/4" flat washer on each 1/4-20 x .59 Bolt and insert through the heat shield then lid and screw into the handle until tight.

Step 8: Smoke Stack / Cap Assembly

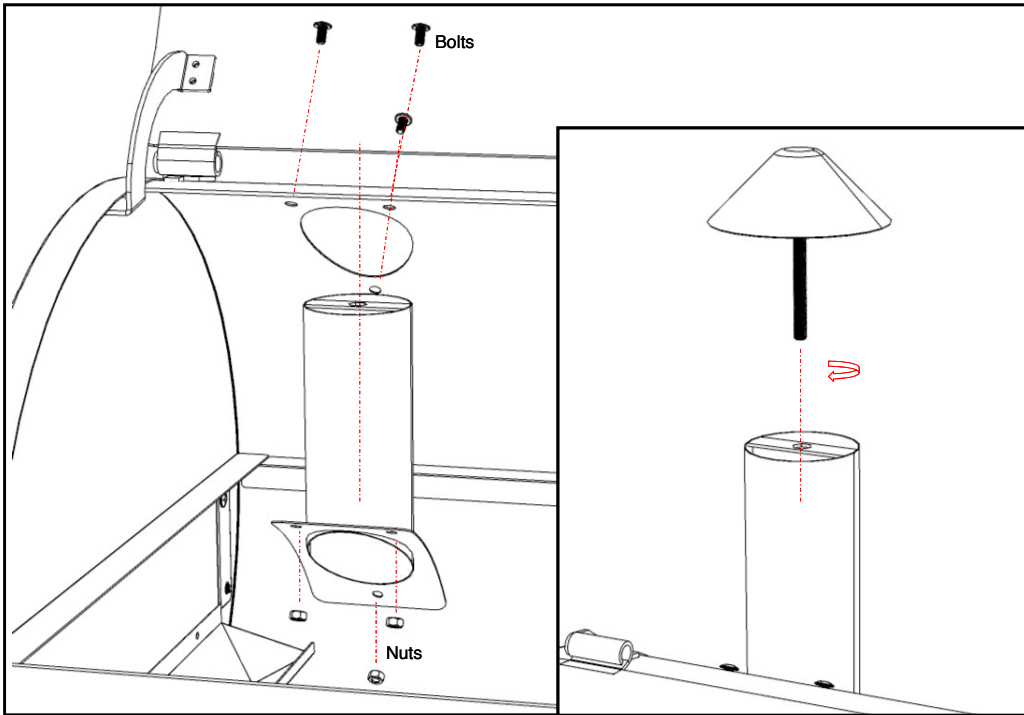

Locate:

- (1) Smoke stack
- (1) Smoke stack cap
- (3) 1/4-20 x .59" bolts
- (3) 1/4-20 nuts

Procedure:

Slide the smoke stack thru the hole in the barrel and attach with (3) 1/4-20 x .59" bolts and (3) 1/4-20 nuts. Screw the smoke stack cap onto the top of the smoke stack as shown. NOTE: The smoke stack is adjustable to allow more or less smoke to exit the smoker. Be careful not to raise cap too high allowing it to come unscrewed from stack.

Step 9: Baffle / Heat Plate / Grid / Bucket Assembly

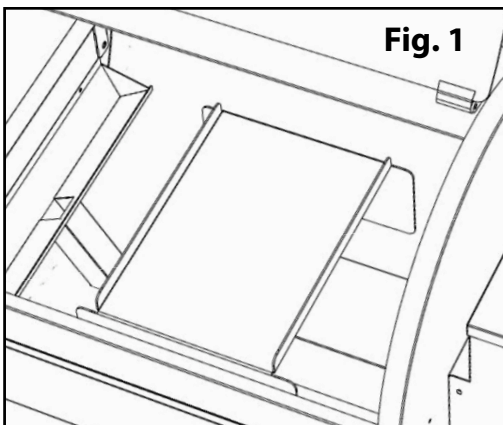

Fig. 1

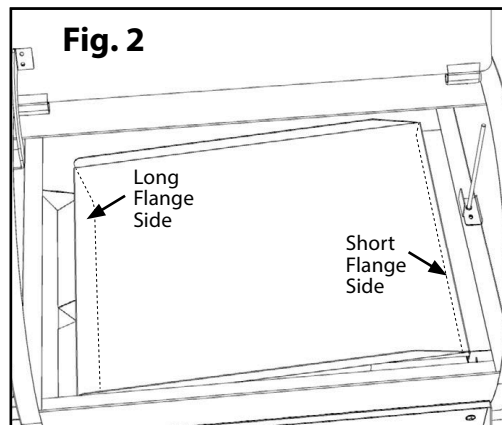

Fig. 2

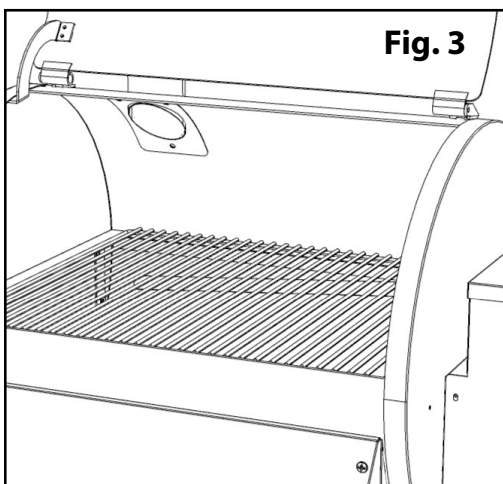

Fig. 3

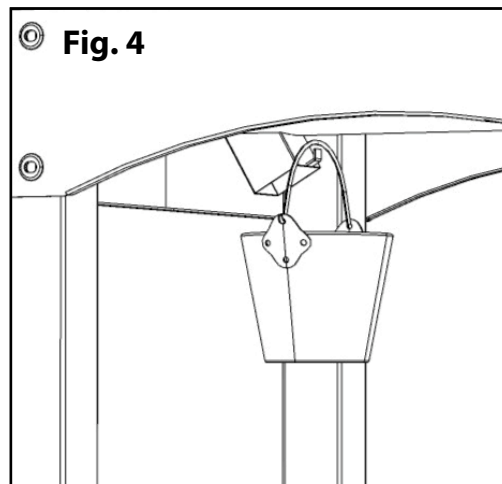

Fig. 4

Locate:

- (1) Heat Baffle
- (1) Grease Pan
- (1) Cooking Grid
- (1) Grease Bucket

Procedure:

Position the Heat baffle directly over the firebox on the locating brackets found on the inside walls of the barrel. The notched legs of the baffle should be facing downward over the locating brackets (Fig. 1). Position the grease drain pan so that the large flange end hooks over the grease drain pan support on the left end of the grill. The short flange should rest on the bracket on the right end of the grill as shown (Fig. 2).

Recommendation: For ease of cleanup, cover the grease drain pan with heavy-duty aluminum foil. Be sure edges and ends of the foil are tight against the bottom of the grease drain pan.

Position the cooking grid on the front and back grid supports that run the full length of the cooking chamber as shown (Fig. 3). Hang the grease bucket on the grease drain tube located under the left side of the barrel as shown (Fig. 4).

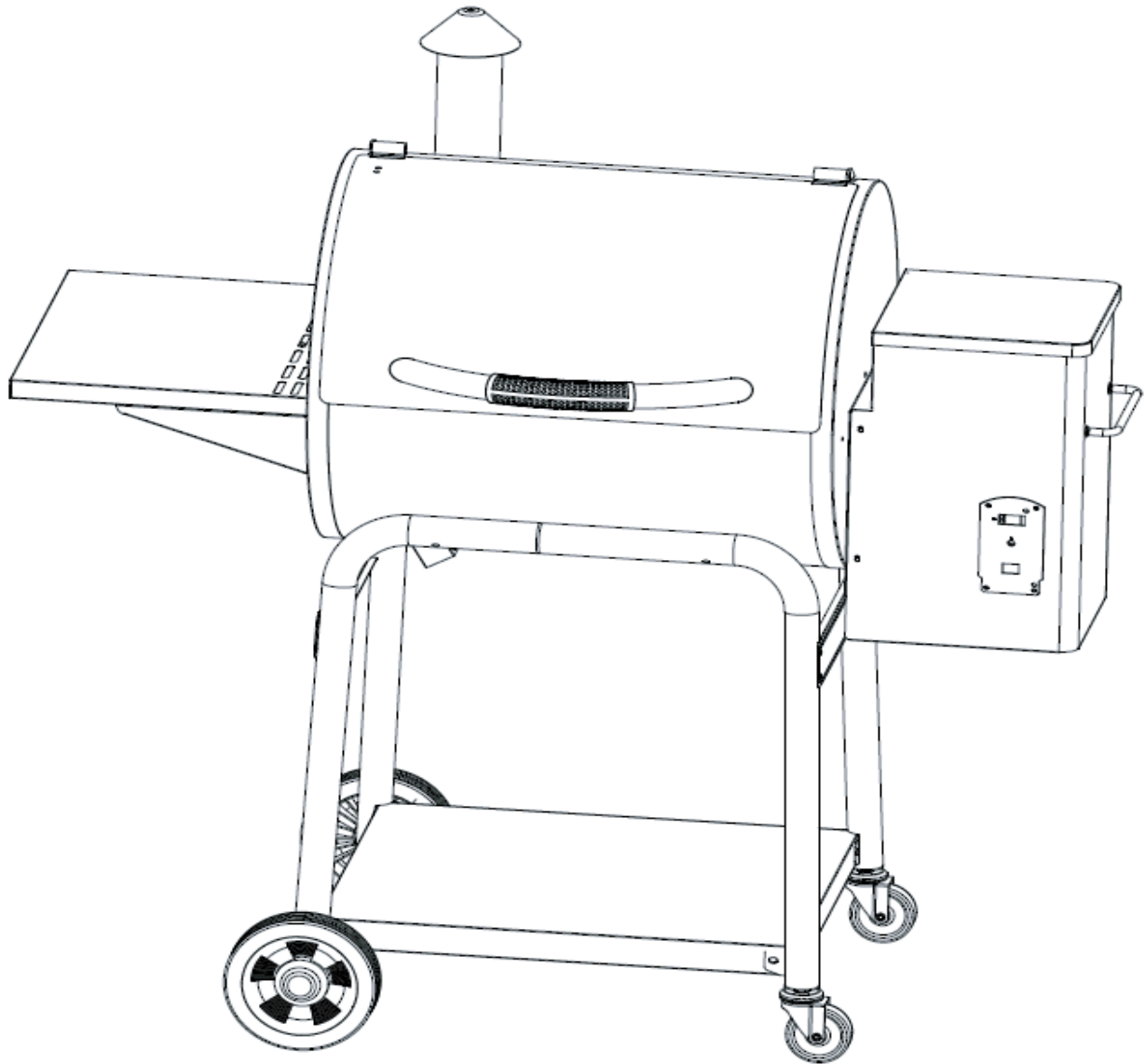

**ASSEMBLY OF YOUR PELLET GRILL IS NOW COMPLETE.
FOR YOUR SAFETY, FOLLOW ALL SAFE GUARDS
AND INSTRUCTIONS.**

Initial Firing Instructions

FOLLOW THESE INSTRUCTIONS THE FIRST TIME YOU FIRE THE GRILL AND WHENEVER IT RUNS OUT OF PELLETS.

FIRE THE GRILL

Open the lid and remove the porcelain grid, grease drain pan and heat baffle from inside the grill. Make sure the power switch is in the OFF position. Plug the power cord into an appropriate, grounded electrical outlet.

Open the pellet hopper lid and locate the auger. Make sure there are no foreign objects in the auger, then turn the power switch to ON and look into the pellet hopper to confirm that the auger is turning. At the same time, place your fingers over the firepot and feel the air movement from the draft inducer fan. **WITHOUT TOUCHING IT, LOOK TO SEE IF THE HOT ROD IS GETTING HOT.** Turn the power switch to OFF.

Fill the pellet hopper with premium 100% hardwood BBQ pellets. Never use wood pellets produced for heating fuel, because they have a high content of softwood which can include pitch and should not be used for cooking. **WARNING: DO NOT USE HEATING FUEL PELLETS AS THEY MAY CONTAIN HAZARDOUS MATERIALS.**

Turn the power switch to ON and the temperature dial to HIGH. When the pellets begin to fall into the firepot, turn the power switch to OFF. Note: this may take some time during the initial charging of the auger.

Turn the power switch to ON and the temperature dial to SMOKE. Let the pellets come to full flame. Once flames are coming out of the firepot, turn the power switch to OFF and let the grill cool.

Recommendation: For ease of clean-up, cover the grease pan with heavy-duty aluminum foil. Be sure the edges and ends of the foil are tight against the bottom of the grease drain pan. Position the heat baffle, grease drain pan and porcelain grid in their proper locations.

SEASON THE GRILL

With the lid open, turn the power switch to ON and the temperature dial to SMOKE. In about two minutes, whitish-gray smoke will come out of the grill as the pellets ignite. Close the lid and set the temperature dial to HIGH.

Run the grill on HIGH for 45 minutes with the lid closed. This seasons the grill and must be done before any food is cooked on it.

Regular Firing Instructions

FOLLOW THESE INSTRUCTIONS FOR REGULAR FIRINGS.

ALWAYS START THE GRILL ON SMOKE SETTING WITH THE LID OPEN.

ONCE THE PELLETS ARE IGNITED, CLOSE THE LID AND SET THE TEMPERATURE DIAL TO THE COOKING TEMPERATURE DESIRED.

With the lid open, turn the Switch/Dial ON (--) and Temperature Dial to SMOKE. In approximately 2 minutes you will notice whitish-gray smoke coming out of the Grill as the pellets ignite. After assuring the pellets have ignited, close the lid and set the Temperature Dial to the cooking setting desired.

The grill should be allowed to pre-heat for about 10 minutes with the lid closed before cooking any food.

If you are smoking at high temperatures and want to return to smoking temperatures, we recommend to set the temperature to 165-170° fahrenheit, allowing for your grill to cool down faster before turning to the smoke setting. NOTE: You may also open the grill lid to help reduce internal temperature faster.

WARNING! If at any time, the Grill fails to light or the fire in the Firepot goes out while cooking or smoking, when sufficient pellets are still in the Pellet Hopper, it is important to follow these steps. Failure to do so may cause a hazardous "over-firing" of your grill due to an excess of unburned pellets in the Firepot.

- 1) DANGER!** Turn the Switch OFF (o) and disconnect the Power Cord. If the Grill is still hot, allow it to thoroughly cool. Open the Lid and remove all food, the Porcelain Grid, Grease Drain Pan and the Heat Baffle.
- 2) WARNING!** Remove all unburned pellets and ash from inside and around the Firepot. **(See instructions for proper handling and disposal of ash in Cleaning and Maintenance Section).**
- 3)** Before replacing the Heat Baffle, Grease Drain Pan and the Porcelain Grid, plug the power cord into an appropriate, grounded electrical outlet and restart the Grill. Pellets should fall into the Firepot and the Hot Rod should begin to heat (it will start to turn red). **CAUTION! Do not touch it.**
- 4)** If this procedure **is** successful, you will soon see flames come out of the Firepot. Then turn the Switch OFF (o), and let the Grill cool down. Position the Heat Baffle, the Grease Drain Pan and Porcelain Grid in their proper locations. With the Lid open, turn the Switch ON (--) and the Temperature/Dial to SMOKE. In approximately 2 minutes you will notice whitish-gray smoke coming out of the Grill as the Pellets ignite. After assuring the Pellets have ignited, close the Lid and set the Temperature/Dial to the cooking setting desired.
- 5)** If this procedure **is not** successful, refer to the troubleshooting tips or contact our Technical Support to help diagnose the problem **before** proceeding to the **MANUAL LIGHTING INSTRUCTIONS.**

Manual Firing Instructions

If the **Hot Rod** only is not operating, the Grill can still be used to cook and smoke using the **MANUAL LIGHTING PROCEDURE** below:

- 1) **DANGER!** Turn the Switch OFF (o) and disconnect the Power Cord. Allow the Grill to thoroughly cool if it is still hot. From beneath the Pellet Hopper, disconnect the Hot Rod (Red / White wire pair as shown in the the wiring diagram near the end of this manual). You will need to remove the Hopper Bottom Panel to access the wiring. Once the Hot Rod is disconnected, replace the Hopper Bottom Panel and plug the Power Cord back into an appropriate, grounded electrical outlet.
- 2) Open the Pellet Hopper and fill with Premium Hardwood BBQ Pellets.

WARNING! USE ONLY PREMIUM 100% HARDWOOD BBQ PELLETS, which are specifically made to work in our grills. NEVER use heating fuel pellets in the Grill due to potential hazardous contaminants and additives that may be present.

- 3) Remove the Porcelain Grid, Grease Drain Pan and Heat Baffle to expose the Firepot in the bottom of the Grill.
- 4) Pour 1/2 cup of Premium Hardwood BBQ Pellets into the Firepot.
- 5) Squirt 2 tablespoons of Alcohol Gel fire lighter into the Firepot on top of the Pellets.

DANGER! Never use gasoline, gasoline-type lantern fuel, kerosene, charcoal lighter fluid or similar liquids to start or “freshen up” a fire in this Grill. Keep all such liquids well away from the Grill when in use.

- 6) Carefully light the Alcohol Gel with a fireplace match or a long-reach butane lighter.

DANGER! Never squirt Alcohol Gel into a burning fire or a hot Firepot. The Alcohol Gel bottle could explode and cause a fire, serious injury or death.

- 7) Let the Alcohol Gel and Pellets burn for approximately 4 minutes.

- 8) After assuring the Pellets have ignited, install the Heat Baffle, Grease Drain Pan and Porcelain Grid back in place.

CAUTION! You will now have a fire in the Firepot. **Be careful not to burn yourself** when you install these components. Gloves are recommended.

- 9) Turn the Switch ON (→) and the Temperature/Dial to the setting desired. With the Lid closed, let the Grill pre-heat for approximately 10 minutes before placing food in the Grill.

CONTROL SHUTDOWN CYCLE

The control for this barbecue comes with an automatic shut down cycle. When finished cooking, turn the Temperature/Dial to “OFF” position. the fan will run for 5 minutes to fully burn the remaining pellets in the burn chamber. When the fan automatically shuts down, the master switch can be switched to the “OFF” position.

Operating Instructions

The temperature dial can be changed at any time to increase or decrease the cooking temperature of the grill. See the table below for recommended temperatures.

HIGH/HIGHER	for grilling
MED/MID RANGE	for slow cooking
SMOKE	for smoking and adding smoke flavor to food for holding foods at about 180°F

The outside temperature effects cooking times. If it is hot outside, cooking times will be less. If it is cold, wet or windy, it will take longer to cook food.

The grill is designed to operate with the lid closed and cooking with the lid open will increase cooking times.

SAFETY INSTRUCTIONS

NOTE: WHEN OPERATING THIS GRILL, MAINTAIN A MINIMUM CLEARANCE OF 12 INCHES FROM GRILL TO COMBUSTIBLES.

Never move the grill when it is hot. Make sure the fire is out and the grill is cold before moving it. Never put water in the firepot to cool it, as this will jam the auger.

NEVER ADD PELLETS BY HAND TO A HOT FIREPOT. This is dangerous and you may be seriously burned. If you run out of Pellets and lose your fire while cooking, let the Grill completely cool and start again with the **INITIAL FIRING INSTRUCTIONS.**

Make sure the heat baffle is properly seated on its locating brackets, as failure to do so may cause flame to come out of the firepot and create a grease fire in the grill. The long flanges of the heat baffle should be pointing down over the firepot.

Clean the grease drain pan, V-shaped grease drain and grease drain tube on a consistent basis to prevent grease fires.

Grease fires are caused by not properly maintaining the Grill by failing to clean your Grease Drain Pan, V-shaped Grease Drain and Grease Drain Tube on a consistent basis. In the unlikely event of a grease fire while cooking, **TURN THE SWITCH/DIAL OFF AND KEEP THE LID CLOSED** until the fire is completely out. Never keep the lid open during a grease fire. If it does not go out, lightly sprinkle baking soda on the fire. **BE CAREFUL NOT TO BURN YOURSELF.** If this does not work, then carefully remove the food from the Grill and keep the lid closed until the fire is completely out. **AGAIN, BE CAREFUL NOT TO BURN YOURSELF.** When the Grill is completely cool, remove the Porcelain Grid and replace the foil on the Grease Drain Pan. Clean any grease accumulation from the V-shaped Grease Drain and the Grease Drain Tube. Replace the Grease Drain Pan and the Porcelain Grid in their proper positions, restart the Grill and resume cooking.

Digital Thermostat Control Functions:

After selecting your cooking temperature (with the exception of "SMOKE") the Auger will operate continuously until the selected temperature is reached. From that point forward, the Digital Control will cycle the Auger off and on to maintain the selected temperature until the Temperature/Dial is changed. When operating in "SMOKE" mode, the Auger will cycle on for 15 seconds and off for 65 seconds. There is no temperature control with the "Smoke" setting. This timed cycle setting for "Smoke" is a factory pre-set recommended by Smoke Chef Grills to develop a "Smoking" temperature of 150 to 180 degrees Fahrenheit.

However you can change this timed cycle to suit your particular needs. Refer to the Wiring Diagram found near the end of this manual and locate the Smoke Adjustment. It is a switch inside a small hole on the face of the Digital Control to the left of the readout (see Wiring Diagram). While the Digital Control is on, use a very small screwdriver or other pointed object (a bent paper clip works well) to gently depress the switch. When you depress the switch, the readout will change from a temperature to "P" followed by a number. The factory pre-set mentioned earlier is P-2. The setting range is from P-0 to P-9. The "P" readout will change each time you depress the switch. With all "P" settings, the auger on time remains constant at 15 seconds while the off time is influenced by the "P" setting. For example: A P-3 setting will result in an Auger on time of 15 seconds and an Auger off time of 75 seconds, an increase in the off time of 10 seconds from the P-2 setting. Each change in the "P" number -up or down- results in an increase or decrease of 10 seconds for the Auger off time. Increasing the number decreases Smoking Temperature. Decreasing the number increases Smoking Temperature. The Smoke Chef Service Department recommends a setting no higher than P-4. Also, if you do make a smoke adjustment, the temperature on the readout should be monitored. If the temperature is consistently below 160 degrees Fahrenheit while "Smoking", decrease the "P" setting because there is a risk of losing the fire in the Firepot.

WARNING! If the fire in the Firepot goes out while smoking, when sufficient Pellets are still in the Pellet Hopper, it is important to follow these steps. Failure to do so may cause a hazardous "over-firing" of your grill due to an excess of unburned pellets in the Firepot. You may need to decrease the "P" setting to prevent your fire from going out in the "Smoke" mode.

- a) DANGER!** Turn the Switch OFF and disconnect the Power Cord. Allow the Grill to thoroughly cool if it is still hot. Open the Lid and remove all food, the Porcelain Grid, Grease Drain Pan and the Heat Baffle.
- b) WARNING!** Remove all unburned pellets and ash from inside and around the Firepot. (See instructions for proper handling and disposal of ash in the Cleaning and Maintenance section).
- c)** Before replacing the Heat Baffle, Grease Drain Pan and the Porcelain Grid, plug the Power Cord into an appropriate, grounded electrical outlet and turn the Switch **ON**. Pellets should fall into the Firepot and the Hot Rod should begin to heat (it will start to turn red). **CAUTION! Do not touch it.**
- d)** You will soon see flames come out of the Firepot. Then turn the Switch **OFF**, and let the Grill cool down. Position the Heat Baffle, the Grease Drain Pan and Porcelain Grid in their proper locations. With the Lid open, turn the Switch **ON** and the Temperature/Dial to **SMOKE**. In approximately 2 minutes you will notice whitish-gray smoke coming out of the Grill as the Pellets ignite. After assuring the Pellets have ignited, close the Lid and set the Temperature/Dial to any cooking setting desired.

CARBON MONOXIDE:

WARNING! Follow these guidelines to prevent this colorless, odorless gas from poisoning you, your family or others.

- Know the symptoms of carbon monoxide poisoning: headache, dizziness, weakness, nausea, vomiting, sleepiness and confusion. Carbon monoxide reduces the blood's ability to carry oxygen. Low blood oxygen levels can result in loss of consciousness and death.
- See a doctor if you or others develop cold or flu-like symptoms while cooking or in the vicinity of this Grill. Carbon monoxide poisoning, which can easily be mistaken for a cold or flu, is often detected too late.
- Alcohol consumption and drug use increase the effects of carbon monoxide poisoning.

Carbon monoxide is especially toxic to mother and child during pregnancy, infants, the elderly, smokers and people with blood or circulatory problems, such as anemia or heart disease.

Cleaning and Maintenance

Regularly clean grease from the pieces of the unit to prevent grease fires. It is easier to clean off grease when the grill is warm. **DO NOT BURN YOURSELF.**

- Change the aluminum foil on the grease drain pan.
- Clean grease from the V-shaped grease drain and grease drain tube.
- Wipe grease off the interior surfaces of the grill.
- Empty the grease bucket and line with aluminum foil for easy cleanup.

Use warm soapy water to clean the outside grill surfaces and to cut the grease. Do not use oven cleaner, abrasive cleansers or abrasive cleaning pads. During the rainy season, take care that water does not get into the pellet hopper. When wet, wood pellets expand and will jam your auger. Consider getting a Smoke Chef grill cover to protect your grill when it is stored.

Cleaning of Ash from inside and around the Firepot:

DANGER! Turn the switch OFF and disconnect the power cord.

WARNING! Make sure that the Grill is COLD before cleaning the ash.

WARNING! Disposal of ashes should be done only per the following instructions.

Excess ash in the Firepot may cause your fire to go out, especially in the "SMOKE" setting. The Firepot should be inspected occasionally, and cleaned to remove the ash buildup. Again, cleaning the ash from in and around the Firepot should be done only when the Grill is COLD. Remove the Porcelain Grid, Grease Drain Pan and Heat Baffle to provide access to the Firepot and the interior of the Grill. Much of the ash outside of the Firepot can be swept to the open area at the left of the Firepot using a small whisk broom. It can be removed from the Grill with a small metal fireplace shovel or other similar tool. Dispose of the ashes per the following instructions.

WARNING! A vacuum cleaner is the best way to remove ashes from the Firepot but this must be done with extreme care to avoid the risk of fire. Again, cleaning the ash from the Firepot should be done only when the Grill is COLD. A utility-type vacuum cleaner, having a metal collection canister without a bag would be best for this task. However, almost any vacuum cleaner will work safely if this procedure is properly followed. After assuring that the ash in the Firepot is COLD, vacuum the ash from inside of the Firepot.

A) If your vacuum cleaner is a bagless model, empty any previously accumulated debris from the collection chamber. Then vacuum the ash from the inside of the Firepot. Once the Firepot is clean, empty the collection chamber into the metal container described below without delay. Make sure there is no remaining ash residue left in the collection chamber.

B) If your vacuum cleaner is a model that uses a disposable bag, install an unused one in the machine. Then vacuum the ash from the inside of the Firepot. Once the Firepot is clean, remove the bag from the vacuum cleaner and place it in the metal container described below without delay.

DISPOSAL OF ASHES

WARNING! Ashes should be placed in a metal container with a tight fitting lid. The closed container of ashes should be placed on a non-combustible floor or on the ground, well away from all combustible materials, pending final disposal. If the ashes are disposed of by burial in soil or otherwise locally dispersed, they should be retained in the closed container until all cinders have thoroughly cooled.

After removing food from the porcelain grid, brush it with a long-handled cleaning brush. **DO NOT BURN YOURSELF.**

Troubleshooting

THE GRILL FAILS TO IGNITE

IF THE GRILL DOES NOT IGNITE OR THE FIRE GOES OUT IN THE FIREPOT WHILE COOKING, FIRST TRY RE-FIRING THE GRILL:

Turn the power switch to OFF and disconnect the Power Cord.

Remove the porcelain grid, grease drain pan and heat baffle. Also remove any food.

Remove all unburned pellets and ash from the firepot. Make sure the Grill is COLD, as Ash can cause a Fire.

Restart the grill and confirm that the ignition cycle is working. The hot rod should turn red and pellets should fall from the auger into the firepot. Put the porcelain grid, grease drain pan and heat baffle back in place.

IF THE ABOVE PROCEDURE DOESN'T WORK, TRY THESE ADDITIONAL TIPS:

Verify power at the electrical outlet: if the power cord is connected to a Ground Fault Interrupter, check and restart if necessary.

Check the power cord fuses: disconnect the power cord from the electrical outlet, remove the control and check the fuse on back. Replace if the fuse is blown. Be sure to reinstall the control.

Verify that the hot rod, draft inducer fan and auger drive are working:

- **Unplug the hot rod connector, plug the power cord into an appropriate, grounded electrical outlet and turn the power switch to ON.**
- **Check that the draft inducer fan and auger drive motor are working. If one is not working, it needs to be replaced. If both are operating, the hot rod may need to be replaced.**

IF THE PROBLEM IS THE HOT ROD, THE GRILL CAN STILL BE USED BY FOLLOWING THE MANUAL FIRING INSTRUCTIONS IN THIS MANUAL.

NO PELLETS ARE DELIVERED TO THE FIREPOT

Verify that there are pellets in the pellet hopper. Note that it can take up to seven minutes for pellets to travel from the pellet hopper to the firepot.

IF THIS DOESN'T FIX THE PROBLEM, FOLLOW THIS PROCEDURE TO CHECK THAT THE AUGER DRIVE MOTOR AND DRAFT INDUCER FAN ARE WORKING:

Make sure the Power Switch is OFF and the Power Cord is disconnected.

Remove any covers necessary to access the Auger Drive Motor and Draft Inducer Fan connections.

Unplug the auger drive motor (orange/white wire pair) and the draft inducer fan (purple/white wire pair). Then reconnect both pairs. See the wiring diagram in the next section.

Plug the power cord into an appropriate, grounded electrical outlet and turn the power switch to ON.

If the auger drive motor is working, the problem is the digital control, which may need to be replaced.

If the auger drive motor is not working, but the draft inducer fan is working, the problem is the auger system, which may need to be checked:

- Turn the power switch to OFF.
- Locate the small fan blade on the back of the auger motor drive.
- Turn the power switch to ON and watch to make sure the fan blade turns. If it doesn't turn it may need to be replaced. If it turns a bit and then stops, turn the power switch to OFF and see if it unwinds slightly, indicating a jam that needs to be cleared. See the section below for how to clear auger jams.

THE AUGER JAMS

IF FOREIGN OBJECTS OR WET PELLETS JAM THE AUGER SYSTEM, IT NEEDS TO BE REMOVED AND CLEARED:

Making sure the power switch is OFF and the power cord is disconnected, remove any covers necessary to access the auger drive motor.

Remove the screw connecting the auger drive motor shaft to the auger shaft and the screw retaining the auger bushing into the auger tube.

With a small pipe wrench or locking pliers on the auger shaft, turn the auger counter clockwise. It will turn hard until it breaks free.

Remove the auger and clean all pellets, ash or foreign objects from the auger, auger tube and firepot. A shop-vac will help.

Sand the outside surfaces of the auger with medium grit sandpaper. Sand the inside of the auger tube, if necessary. Vacuum sanding grit out of the auger tube and firepot when finished.

Reinstall the auger bushing and the auger into the auger tube, making sure the auger rotates freely. Re-attach the auger shaft to the auger drive motor shaft.

THE GRILL DOESN'T FIRE ON SMOKE SETTING

The "P" number for the Smoke Adjustment on the Digital Control may be set too high. Review the Digital Thermostat Control Functions in the Operating Instructions section to make an adjustment.

FOLLOW THIS PROCEDURE TO CLEAN EXCESS ASH FROM THE FIREPOT:

Make sure the Power Switch is OFF and the Power Cord is disconnected.

Open the lid and remove the porcelain grid, grease drain pan and heat baffle.

Remove all unburned pellets and ash from the firepot. A shop-vac will help. **MAKE SURE THE GRILL IS COLD AS HOT ASH CAN CAUSE A FIRE.**

Put the porcelain grid, grease drain pan and heat baffle back in place and follow the **INITIAL FIRING INSTRUCTIONS.**

Wiring Diagram

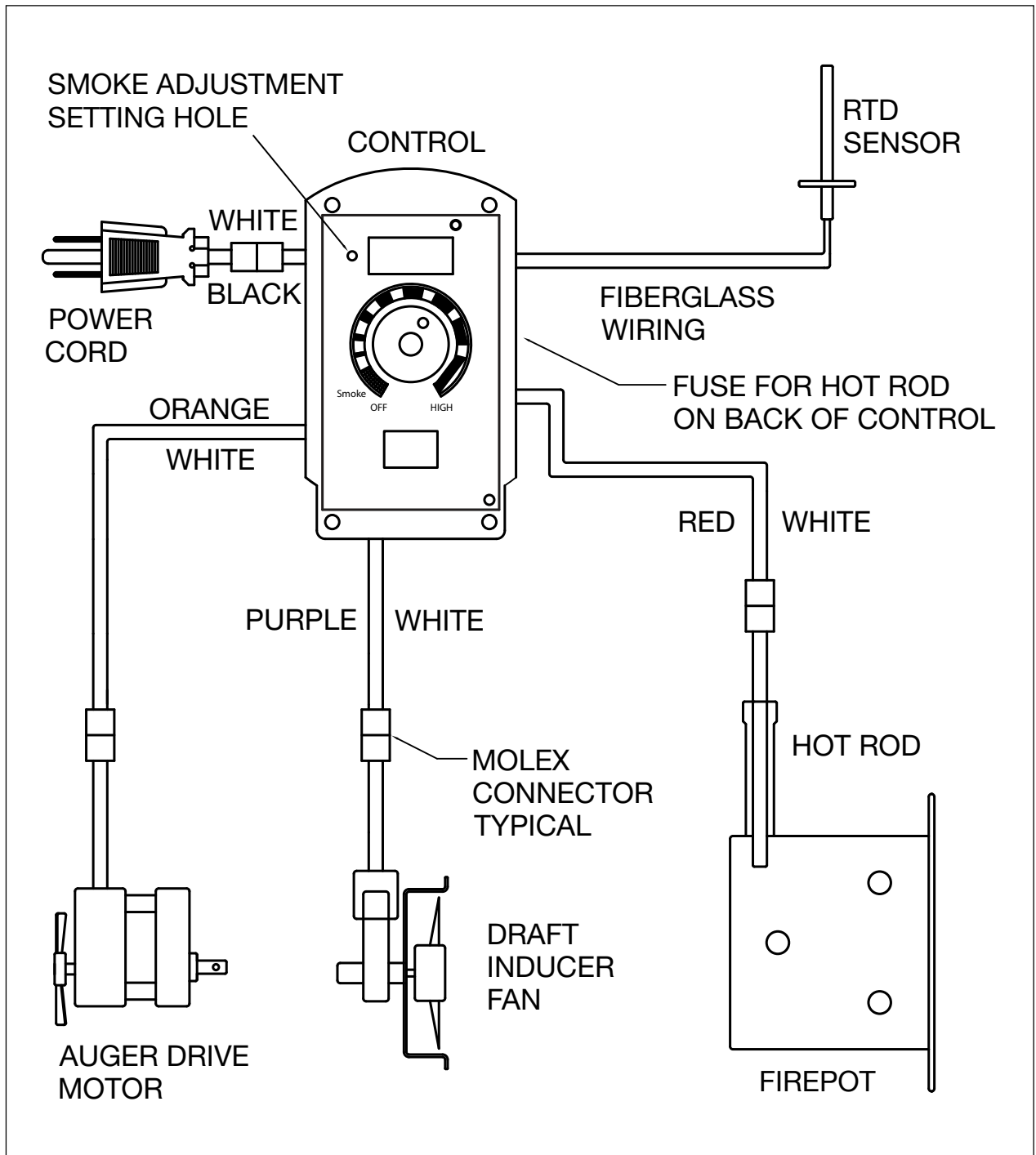

Limited Warranty

This Smoke Chef™ Grill is guaranteed against broken or damaged parts at time of purchase. All parts carry a 1-year limited warranty. Paint is guaranteed to be free of defects for 90 days except for rust, which may appear after repeated use.



This warranty does not cover damage or issues related to neglect, abuse, or modifications to the product. Repair labor is not covered.

All parts that meet the warranty requirements will be shipped at no-charge via the discretion of the Customer Service Department (ground shipments, US Mail, or Parcel Post Only). Any special handling charges (i.e. Second Day, Overnight, etc.) will be the responsibility of the consumer.

All warranty claims apply only to the original purchaser and require a proof of purchase verifying purchase date. Do not return parts to our address without first obtaining a return authorization number from our customer service.

This service is available by calling 866-475-5180, 8:30am to 4:30pm, Central Time, Monday through Friday, or write to Outdoor Leisure Products, Inc., 5400 Doniphan Drive, Neosho, MO 64850.

This warranty may give you specific legal rights that vary by state.

Outdoor Leisure Products, Inc
5400 Doniphan Drive
Neosho, MO 64850
www.olp-inc.com

©2014 Outdoor Leisure Products, Inc. and the Smoke Chef™ logo are trademarks of Outdoor Leisure Products, Inc. and are not to be used without express permission by Outdoor Leisure Products, Inc.