

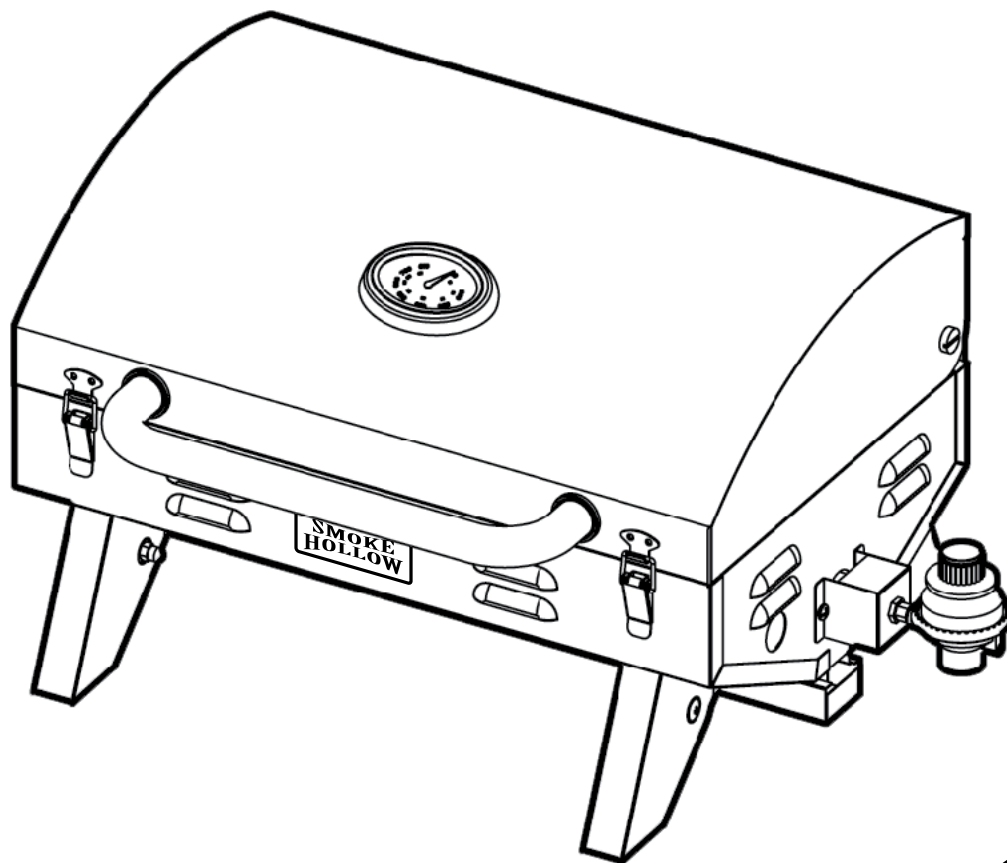

Owner's Manual **Tabletop Gas Grill**



Model # 105



**THIS IS YOUR ASSEMBLY, CARE & USE MANUAL
WITH IMPORTANT WARNING & SAFETY INFORMATION.
PLEASE SAVE THESE INSTRUCTIONS.**

Approximate assembly time: 20 minutes
Tools needed for assembly: Phillips head screwdriver

FOR OUTDOOR USE ONLY

WARNING

THIS MANUAL CONTAINS IMPORTANT INFORMATION NECESSARY FOR THE PROPER AND SAFE USE OF THIS UNIT. READ AND FOLLOW ALL WARNINGS AND INSTRUCTIONS BEFORE USING GRILL AND DURING USE.

FAILURE TO FOLLOW THESE WARNINGS AND INSTRUCTIONS PROPERLY COULD RESULT IN FIRE OR EXPLOSION THAT COULD CAUSE PROPERTY DAMAGE, PERSONAL INJURY OR DEATH.

DANGER

DO NOT USE GAS GRILL FOR INDOOR COOKING OR HEATING. TOXIC FUMES CAN ACCUMULATE AND CAUSE ASPHYXIATION. DO NOT USE IN OR ON BOATS OR RECREATIONAL VEHICLES.

IF YOU SMELL GAS - SHUT OFF GAS TO THE APPLIANCE - EXTINGUISH ANY OPEN FLAME - OPEN LID - IF ODOR CONTINUES, KEEP AWAY FROM THE APPLIANCE AND IMMEDIATELY CALL YOUR GAS SUPPLIER OR YOUR FIRE DEPARTMENT.

IMPORTANT SAFEGUARDS

WARNING

- Do not store or use gasoline or other flammable liquids or vapors in the vicinity of this or any other appliance.
- An LP cylinder not connected for use shall not be stored in the vicinity of this or any other appliance.
- When cooking with oil/grease, do not allow the oil/grease to exceed 350°F (177°C).
Do not store or use extra cooking oil in the vicinity of this or any other appliance.
- This grill is for use with propane gas only (propane gas cylinder not included).
- Never attempt to attach this grill to a self-contained propane system of a camper trailer, motor home or house.
- Never use charcoal or lighter fluid with the gas grill.
- Do not use gasoline, kerosene or alcohol for lighting. The LP-gas supply cylinder must be constructed and marked in accordance with the specifications for propane gas cylinders of the U.S. Department of Transportation (DOT) CFR 49. This grill is not intended to be used in or installed on recreation vehicles and/or boats.
- Do not attempt to move the grill while it is lit.
- Do not use the grill unless it is completely assembled and all parts are securely fastened and tightened.
- Keep all combustible items and surfaces at least 36 inches (91.4cm) away from grill at all times.
- DO NOT use this grill or any gas product near unprotected combustible constructions.
- Do not attempt to move the grill while it is lit.
- Do not use in an explosive atmosphere. Keep grill area clear and free from combustible materials, gasoline and other flammable vapors and liquids

Continued on next page.

IMPORTANT SAFEGUARDS

- Do not touch metal parts of grill until it has completely cooled (about 45 minutes) to avoid burns, unless you are wearing protective gear (BBQ mittens, pot holders, etc.)
- Do not alter this grill in any manner.
- Never keep a filled container in a hot car or car trunk. Heat will cause the gas pressure to increase, which may open the relief valve and allow gas to escape.
- Keep the grill's valve compartment, burners and circulating air passages clean. Inspect the grill before each use.
- This grill is for outside use only, and should not be used in a building, garage or any other enclosed area.
- The use of alcohol, prescription or non-prescription drugs may impair the operator's ability to properly assemble or safely operate the grill.
- Always open grill lid slowly and carefully as heat and steam trapped within the grill can burn you severely.
- Do not leave a lit grill unattended. Keep children and pets away from the grill at all times.
- Do not use the grill in high winds.
- Never fold or transport grill while LP cylinder is attached.

DANGER

LIQUID PROPANE (LP) GAS IS FLAMMABLE AND HAZARDOUS IF HANDLED IMPROPERLY. KNOW ITS CHARACTERISTICS BEFORE USING ANY PROPANE PRODUCT.

- Propane Characteristics: Flammable, explosive under pressure, heavier than air and settles in pools and low areas.
- In its natural state, propane has no odor. For your safety, an odorant has been added.
- Contact with propane can cause freeze burns to skin.
- This grill is shipped from the factory for propane gas use only.
- Never use a propane cylinder with a damaged body, valve, collar or footing.
- Never refill a 1 lb. cylinder.
- Dented or rusted propane cylinders may be hazardous and should be checked by your propane gas supplier.

The LP Gas Cylinder, for use with this LP gas grill, must meet the following requirements:

- 1 lb. capacity
- Constructed and marked in accordance with Specifications for LP Gas Cylinders of the U.S. Dept. of Transportation (DOT) or the National Standard of Canada, CAN/CSA-B339, Cylinders, Spheres and Tubes for Transportation of Dangerous Goods; and Commission, as applicable (See collar for marking)
- Marked "Propane."
- Provided with a cylinder connection device that is compatible with the grill's connection.

WARNING

CALIFORNIA PROPOSITION 65

This product contains, or the use of this product releases, chemicals known to the State of California to cause cancer and birth defects or other reproductive harm.

For more information go to www.P65Warnings.ca.gov.



Congratulations

on your purchase of your new
Smoke Hollow® LP Gas Tabletop Grill.

With proper set-up, operation and maintenance, this appliance will provide you with years of delicious food and cooking enjoyment.

IMPORTANT

When you un-pack your grill, remove all parts and packaging material from the box and inside the grill. Make sure you have all the items on the parts list. Carefully check the unit and make sure there is no damage.

IF YOU HAVE ANY PROBLEMS WITH THIS PRODUCT OR THERE ARE MISSING OR DAMAGED PARTS , PLEASE CALL CUSTOMER SERVICE TOLL FREE 1-866-475-5180 (Monday–Friday, 8:30 am–4:30 pm, CST).

NOTE : DO NOT RETURN UNIT TO THE STORE BEFORE CALLING THE TOLL FREE NUMBER. Do not dispose of your cartons until you are completely satisfied with your new Smoke Hollow grill.

Parts and Tool List

NOTE:

Some illustrations may vary slightly depending on grill model, however the names are the same.

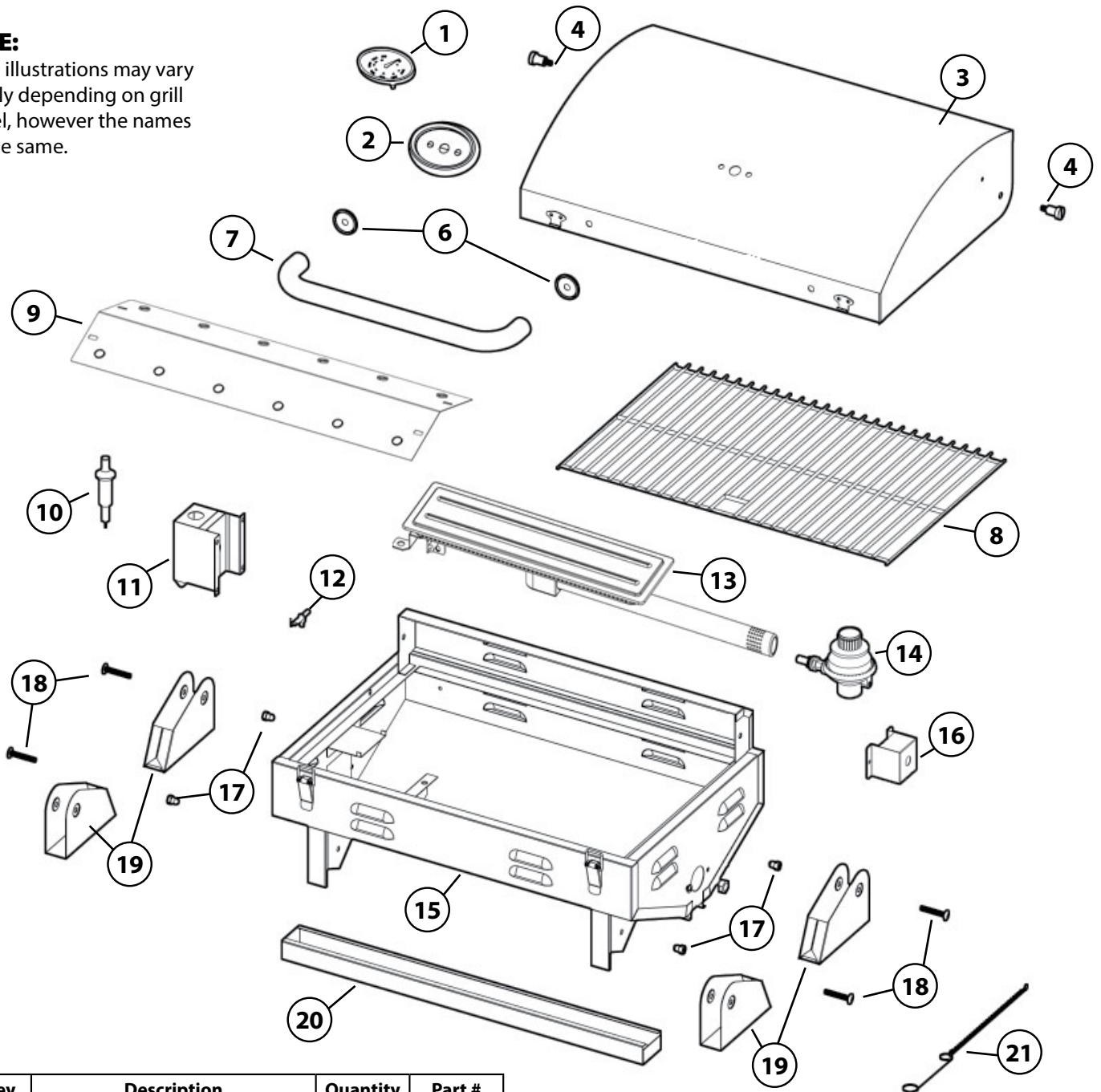

Key	Description	Quantity	Part #
1	Thermometer	1	205-1
2	Thermometer Bezel	1	205-2
3	Hood	1	105-1
4	Hood Pivot Pin	2	205-3
5	Hood Pivot Pin Nut (not shown)	1	205-4A
6	Hood Handle Bezel	2	205-5
7	Hood Handle	1	205-6
8	Cooking Grid	1	205-8
9	Flavor Activator	1	105-2
10	Piezo Igniter	1	205-10
11	Igniter Housing	1	105-3
12	Electrode (wire not shown)	1	105-4

Key	Description	Quantity	Part #
13	Burner	1	105-5
14	Regulator/Valve	1	205-14A
15	Grill Firebowl	1	105-6
16	Regulator Housing	1	105-7
17	Leg Nut	4	205-17
18	Leg Bolt	4	205-18
19	Leg	4	105-8
20	Drip Tray	1	105-9
21	Match Holder	1	N/A

Grill Assembly

1. Hood Handle Assembly

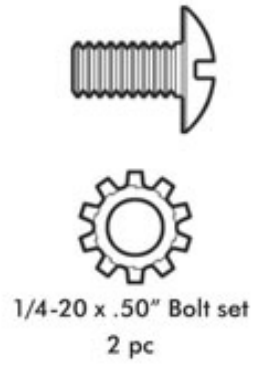
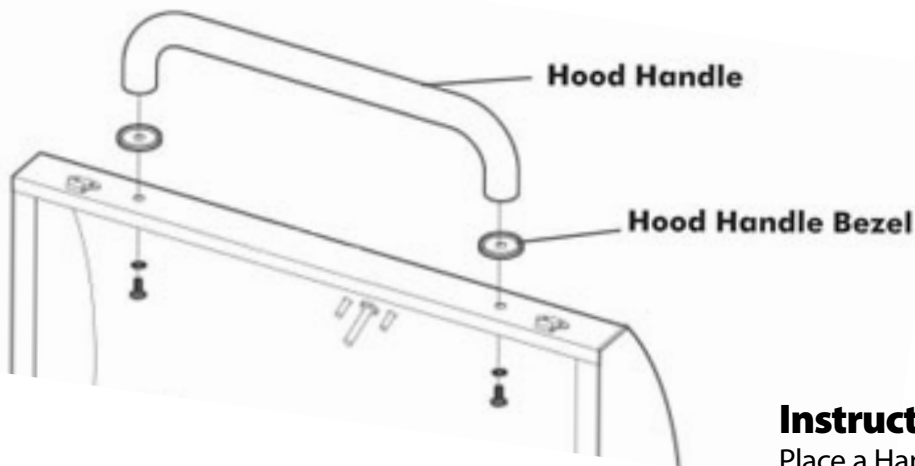

Instructions:

Place a Handle Bezel between each end of the handle and the grill hood then insert a 1/4-20 x .50" Bolt through the inside of the hood into each end of the handle. Tighten the bolts.

2. Regulator-Valve Housing Assembly

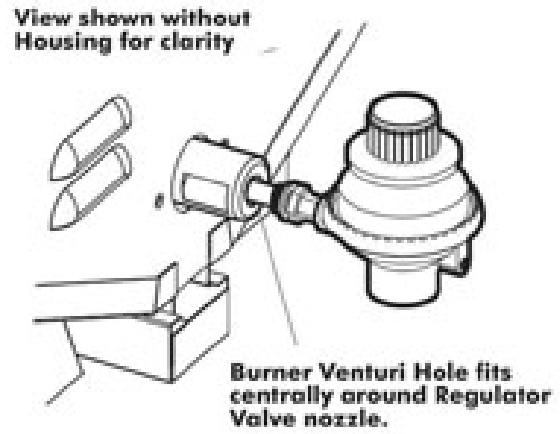
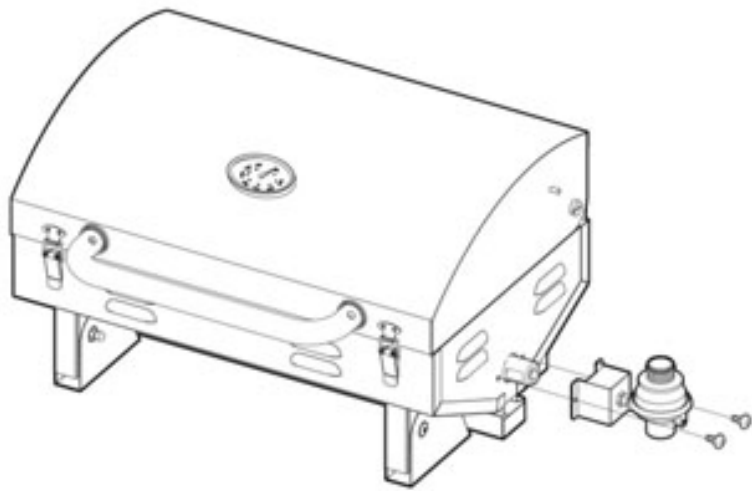

Instructions:

Insert the end of the regulator valve nozzle into the open end of the burner tube (venturi). Align the holes in the Regulator Housing with the threaded holes in the grill firebowl and insert two 5/32 x .31" Bolts through the holes in the housing into the threaded holes in the firebox. Tighten the bolts securely.

Grill Assembly

3. Igniter Housing Assembly

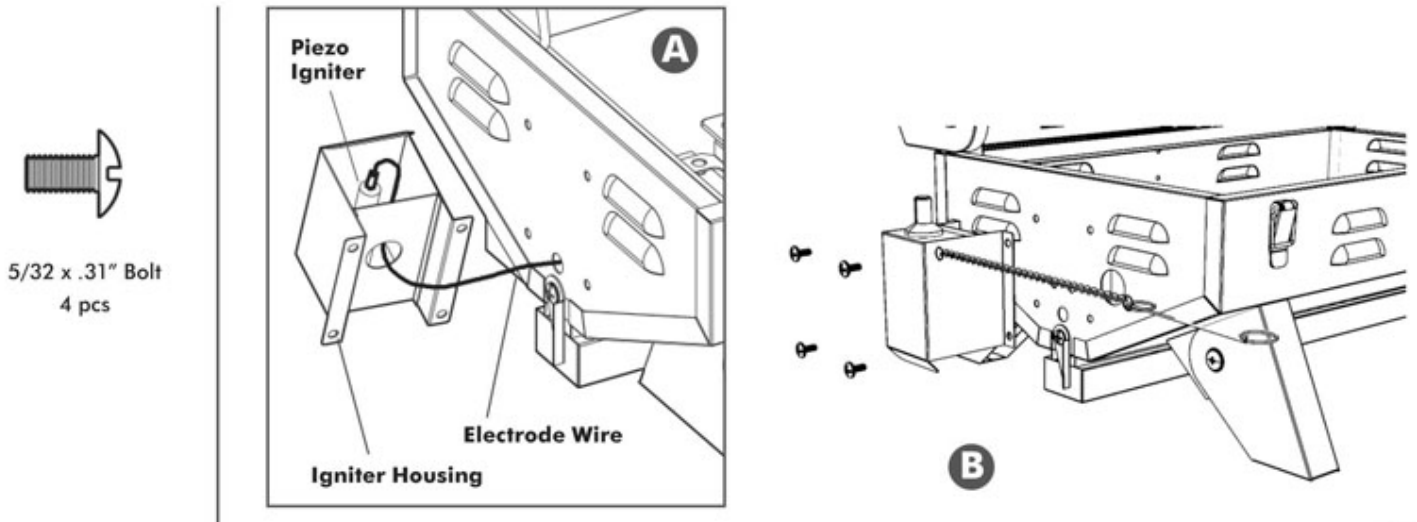

Instructions:

A. Thread the Electrode Wire through the hole in the Igniter Housing and attach the end onto the pin at the bottom end of the Piezo Igniter.

B. Align the holes in the Igniter Housing with the threaded holes in the firebowl end. Insert Four 5/32 x .31" Bolts through the housing into the threaded holes. When installing the fourth bolt, first insert it through the ring at the end of the Match Holder chain and then through the Housing and into the firebowl end. Tighten the bolts securely.

**ASSEMBLY OF YOUR GRILL IS NOW COMPLETE.
FOR YOUR SAFETY, FOLLOW ALL SAFE GUARDS AND INSTRUCTIONS.**

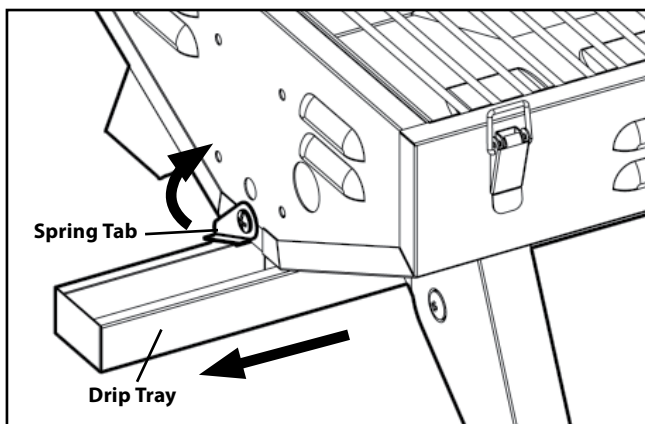

Drip Tray Access:

The Drip Tray is accessed for cleaning by rotating the spring tab and sliding the tray out from under the grill.

NOTE: Shown here without Igniter Housing for clarity.

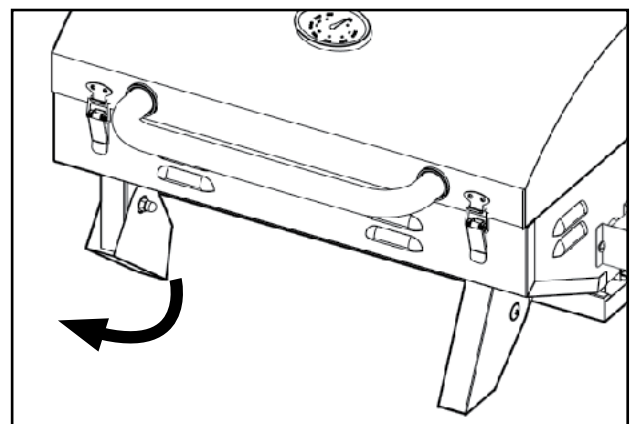

Tabletop Use:

Unfold the legs, as shown and place grill on a level surface. When legs are unfolded completely they will snap into the open position. Dimples in the legs help them remain in position. To close, simply apply enough pressure to overcome the friction fit.

Before Using Your LP Gas Grill

Installation Codes

⚠ WARNING ⚠

To reduce the risk of serious bodily injury or death from fire or explosion:

- This installation must conform with local codes or, in the absence of local codes, with either the National Fuel Gas Code, ANSI Z223.1/NFPA 54 Natural Gas and Propane Installation Code, CSA B149.1, or Propane Storage and Handling Code, B149.2 or the Standard for Recreational Vehicles, ANSI A 119.2/NFPA 1192 and CSA Z240 RV Series, recreational Vehicle Code, as applicable.
- If an external electrical source is utilized, the outdoor cooking appliance, when installed, must be electrically grounded in accordance with local codes or, in the absence of local codes, with the National Electrical Codes, ANSI/NFPA 70, or the Canadian Electrical Code CSA C22.1.
- Keep any electrical supply cord and the fuel supply hose away from any heated surfaces.

Selecting a Location

⚠ WARNING ⚠

To reduce the risk of serious bodily injury or death from fire or explosion:

- Use this outdoor cooking appliance only outdoors and never in a building, garage, breezeway, carport, porch or in any enclosed area. Locate outdoor cooking appliance in an area with good ventilation, on a level stable surface and clear of combustible and flammable material.
- Locate your LP gas grill at least 10 feet away from your house or any building.
- Maintain minimum clearances of 10" from back and sides of grill to any combustible construction.
- Do not locate this appliance under overhead, unprotected combustible construction.
- This outdoor cooking appliance is not intended to be used in/on boats or installed in/on recreational vehicles.
- Never use gas grill as a space heater.

Performing a Leak Test

⚠ WARNING ⚠

- Perform a leak test before lighting your grill for the first time.
- Perform a leak test if any gas component is changed.
- Perform a leak test after travel, especially over rough or bumpy roads.
- Perform a leak test a minimum of once a season.
- Perform a leak test after a prolonged period of storage or non-use.
- Perform leak tests in a well ventilated area.
- Never use an open flame to test for gas leaks.
- Never smoke near the grill during a leak test.
- Do not perform a leak test on a grill while it is hot or in use.
- Do not use the gas grill if you detect a gas leak that cannot be corrected by using the leak test procedures.

Before Using Your LP Gas Grill

Connecting LP Gas Cylinder

1. Purchase 1lb. LP Gas cylinder at your local retailer.
2. Turn the regulator knob to the “Off” position.
3. Remove protective cap from regulator opening. Remove plastic cap from top of propane cylinder. Save cylinder cap for replacement on cylinder if gas remains in cylinder after use.
4. Insert the 1lb. LP Gas cylinder into the threaded hole in the underside of the regulator. Turn the cylinder clockwise until firmly seated. Hand tighten only.
5. For optimum performance, allow cylinder to hang vertically off the edge of the table when there is no danger of being bumped or disturbed.

NOTE: NEVER FOLD UP OR TRANSPORT GRILL WITH CYLINDER ATTACHED.

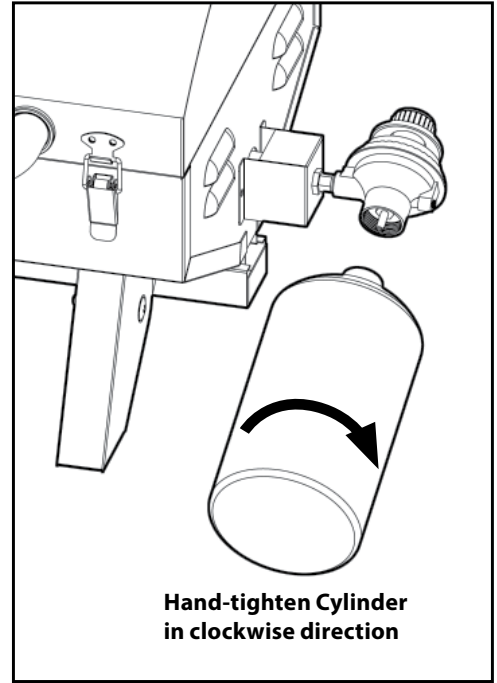

Disconnecting LP Gas Cylinder

1. Turn regulator knob to the “Off” position.
2. Remove the cylinder by turning counterclockwise.
3. Replace the protective cap over the regulator opening. Replace the plastic cap on the top of propane cylinder for storage if not empty.
4. Store cylinder outdoors and away from grill.

How to Perform a Leak Test - “FIRST TIME USE”

SUPPLIES NEEDED:

- Clean Paint Brush
- Water
- Dish Washing Liquid
- Empty bowl or Can

1. Make sure the regulator knob is turned to the “Off” position and verify that the LP Gas Cylinder is tightened securely to the regulator.
2. Mix one part of water with one part of dish washing liquid.
3. Brush mix on Regulator, Propane Cylinder and connection as indicated by the heavy arrows in the figure below. If bubbling occurs, there is a gas leak.
 - A. If leak appears at the regulator/cylinder connection, repeat cylinder installation procedure, but do not overtighten. (NOTE: Only hand tighten) Repeat leak test.
 - B. If the leak is coming from the Gas Cylinder or if the leak cannot be stopped, remove the cylinder and DO NOT USE THE GRILL. Call Customer Service at 1-866-475-5180. Be sure to have the grill model number and serial number printed on the label, located on the inside of the rear leg. If you need a replacement part under warranty, a proof of purchase will be necessary.

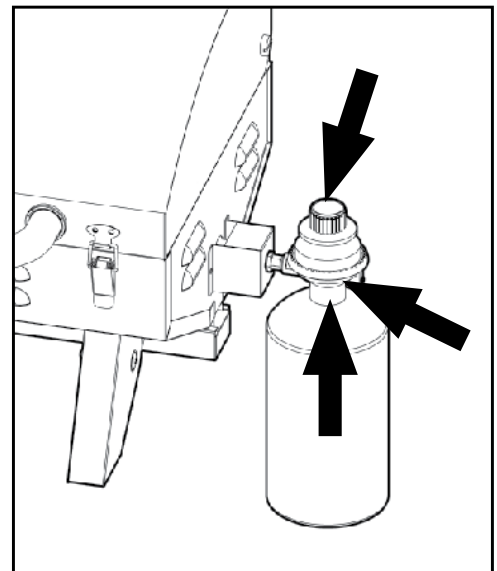

Lighting the Grill

▲ WARNING ▲

To reduce the risk of serious bodily injury or death from fire or explosion:

- Open Hood before lighting the grill to release trapped gas.
- During failed lighting attempts, or if the Burner goes out during operation, turn Control Knob “Off” to dissipate any accumulated gas. Wait five minutes before repeating lighting procedure.

1. Open the Hood.
2. Push the Regulator Knob in and turn 270 degrees (or 3/4 turn) counterclockwise to the High position (Fig. 2). Note the triangular indicator mark on the silver regulator housing.
3. Push the Igniter Button in repeatedly until the Burner is lit. Listen for the click indicating spark ignition, and look to make sure the Burner is lit.

If the Burner goes out during operation, turn Regulator Knob to the “Off” position. Open Hood and wait five minutes before attempting to relight the grill to allow any accumulated gas to dissipate.

If Burner fails to light after three to four attempts, turn Regulator Knob to the “Off” position and allow any accumulated gas to dissipate. Check for igniter spark by pushing igniter button and looking at the igniter tip. If no spark, adjust gap between electrode tip and burner to 3/16” (Fig. 3). If still no spark, see **Troubleshooting Section**.

Wait five minutes; then repeat the lighting procedures. The Burner can also be lit manually, see **Manual Lighting of the Grill** on next page. Should you notice that your Burner is getting hard to light or the flame is not as hot as it once was, refer to the “**How to Clean your Burner**” to remove any possible obstructions.

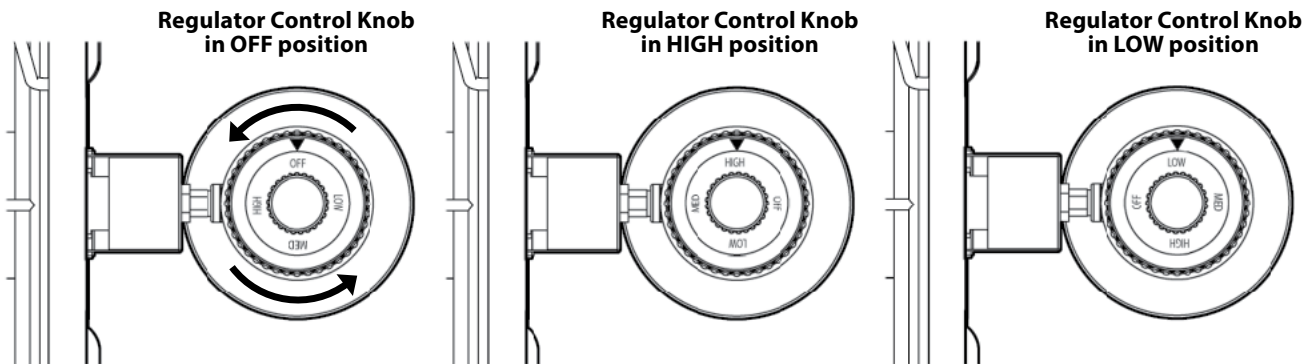
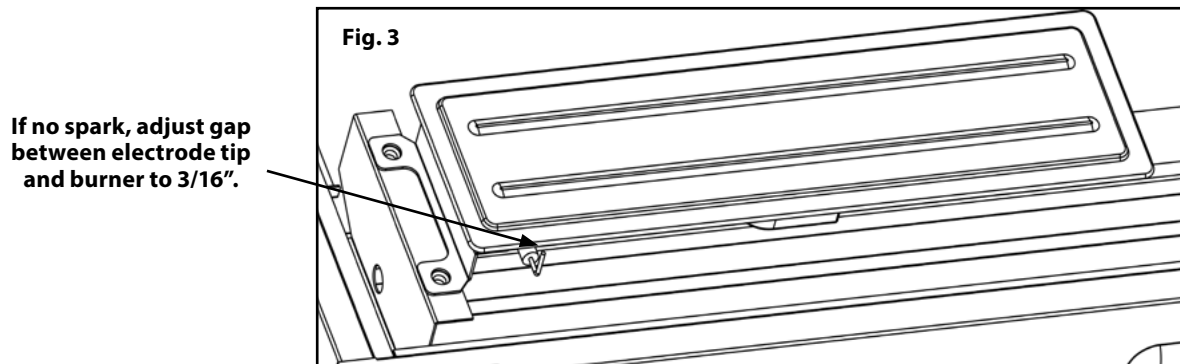

Fig. 2



Manually Lighting the Grill

1. Open the Hood. **IMPORTANT:** Make sure Regulator Knob is turned “OFF”.
2. While holding a lit match near the burner (Fig. 4), push the Regulator Knob in and turn 270 degrees (or 3/4 turn) counterclockwise to the High position.

If the Burner goes out during operation, turn Regulator Knob to the “Off” position. Open Hood and wait five minutes before attempting to relight the grill to allow any accumulated gas to dissipate.

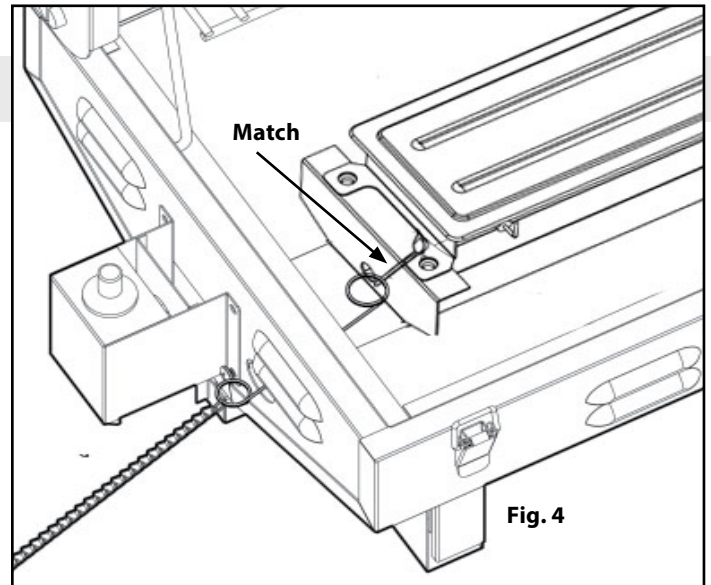

Check the Flame

⚠ WARNING ⚠

To reduce the risk of death or serious injury from an explosion or a fire:

- Regularly inspect and clean Burner/Venturi Tube for insects or insect nests, especially after periods of storage. Spiders or small insects can build nests, webs, and lay eggs in the grill's Venturi Tube, obstructing the flow of gas to the Burner. (Fig. 6) The backed-up gas can ignite and cause a fire. This is known as a “flashback”.
- Be sure Burner is re-installed properly before using grill.

The Burner has been preset by the manufacturer for optimal flame performance. A blue flame, possibly with a small yellow tip, is the result of the optimal air and gas mixture. (Fig. 5)

Check the flame before each cooking session and throughout the grilling season. Check the flame, especially after long periods of storing the grill. Note that the minimum flame height should be 1/4”. If the flame is significantly yellow in color, the appropriate amount of LP gas in the air/LP gas mixture is not correct. This could be due to a blocked Burner from grease drippings or from insects building a nest inside the Burner or Burner opening. Should you notice that your Burner is getting hard to light or the flame is not as hot as it once was, refer to the “**How to Clean your Burner**” section to remove possible obstructions.

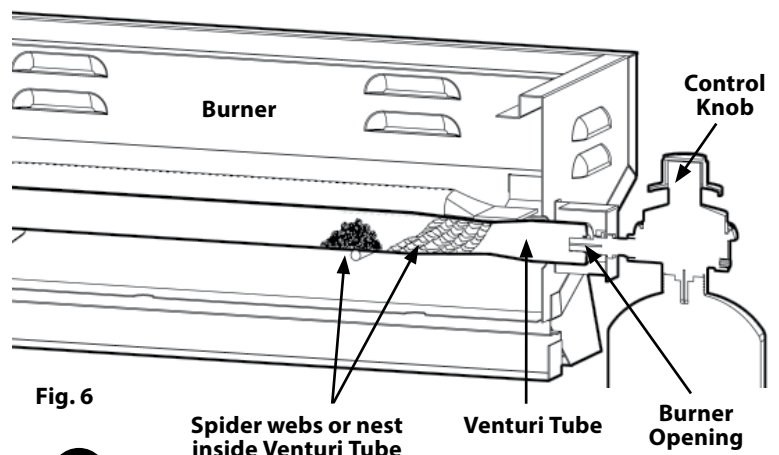
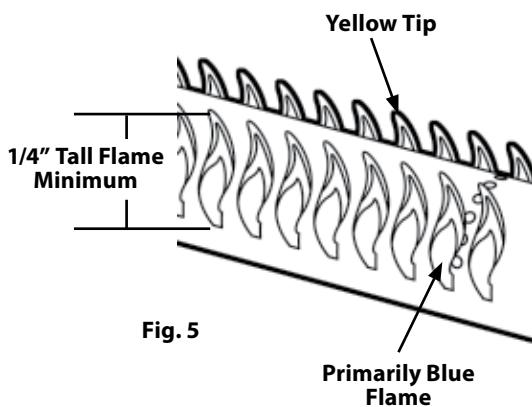

Cooking On the Gas Grill

⚠ WARNING ⚠

To reduce the risk of serious bodily injury or death from fire, explosion or burn hazard:

- Never use charcoal or lighter fluid in your gas grill. Keep this outdoor cooking appliance clear and free from combustible materials, gasoline, and other flammable vapors and liquids.
- Keep any electrical supply cord and regulator hose away from any heated surfaces.
- Make sure there are no gas leaks or obstructions to the flow of combustion and ventilation air before each use.
- Always open the Hood before lighting the LP gas grill.
- Do not attempt to extinguish a grease fire with water or other liquids. Have a BC or ABC fire extinguisher readily accessible. Never douse or spray the grill or cooking surfaces with water when hot. Burns from grease or water splatters could occur.
- If your gas grill catches on fire:
 - if the fire is in the grill portion and you can safely reach the Regulator Knob, then turn it to the “Off position.
 - If the fire involves the LP Gas Cylinder, leave it alone, evacuate the area, and call the Fire Department.
 - If there is any type of fire that threatens either personal safety or endangers property, call the Fire Department.
- Do not use the grill without Drip Tray in place. Check the Drip Tray for build-up. Empty excess grease before each use to reduce the risk of a grease fire in the Drip Tray.
- Do not place containers of oil or grease on or near the grill.
- Do not operate a gas grill if you have knowledge of or suspect a gas leak.
- Do not leave grill unattended.
- Do not wear loose clothing (hanging shirt tails, clothing with frills, etc.) around a gas grill while in use or hot.
- Do not lean your body over the gas grill when lighting it or while it is in use or hot.
- Do not touch hot surfaces. Use heat-resistant gloves, long-handled tongs, or cooking mitts at all times, since the grill will become very hot. Open the Hood carefully when cooking to avoid burns from the hot air and steam trapped inside.
- Do not allow children to operate or play near a gas grill. Keep children, animals and bystanders out of the grill area.
- Do not move an LP gas grill when in use or hot.
- When grill is not in use, turn off all grill Regulator Knob, and disconnect the LP Gas Cylinder.
- Do not cover more than half (50%) of the cooking area if using griddle plates. Full coverage of cooking area will cause overheating below the plates.
- Do not leave any utensils or cookware on a hot cooking surface.

To reduce risk of burn injury from flame roll out or hot air/steam trapped inside grill, open Hood carefully.

Grill Cooking (Direct cooking on the Grids)

Food is cooked directly over the heat source. The Burner heats up the Flavor Activator under the Cooking Grid, which in turn heats the food on the grill. The natural food juices from cooking fall onto the hot Flavor Activator below and vaporize. Rising smoke bastes the food, giving it that unique barbecued flavor.

Use the Direct Cooking method for foods that take less than 25 minutes to cook: steaks, chops, kabobs, sausages, and more. These foods should be turned once halfway through the grilling time.

To sear meats, place them over Direct High heat for 2 to 5 minutes per side. Smaller pieces require less searing time. Hamburgers, steaks, chops, chicken breasts, and larger cuts of meat all benefit from searing. Usually after searing you finish cooking the food at a lower temperature.

For Direct Cooking, preheat the grill for 10 minutes with the Burner on “High”. Place food on the Cooking Grid, and then adjust the Burner to the temperature required. Close the Hood and lift it only to turn food or to test for doneness at the end of the recommended cooking time.

Controlling Flare-Ups:

Flare-ups are part of cooking meats on a grill. This adds to the unique flavor of barbecued food. However, excessive flare-ups can overcook your food and create a dangerous situation for you and your grill. Excessive flare-ups may result from large amounts of fat on the food being cooked or the build up of grease in the grill. If excessive flare-ups occur, DO NOT pour water on the flames. This can cause grease to splatter and could result in serious burns or bodily harm. If a grease fire occurs, turn off the burner until the grease burns out. To prevent or minimize flare-ups, trim all excess fat or skin from meats before grilling and keep the grill and drip tray cleaned of excess grease.

End of Cooking Session

⚠ WARNING ⚠

To reduce the risk of death or serious injury from fire or burn hazard:

- Allow grill and grease in the Drip Tray to completely cool before emptying, cleaning, moving, or storing grill.
- Empty the Drip Tray after each cooking session so grease does not accumulate.

1. After each cooking session, close the Hood and turn the Burner to the “High” position and burn for five minutes. This will burn off some cooking residue, thus making cleaning easier.
2. When you have finished using your grill, turn the Regulator Knob clockwise to the “Off” position.
3. Remove the propane cylinder and replace the protective cap over the regulator opening. Replace the plastic cap on the top of propane cylinder for storage if not empty.
4. Store cylinder outdoors and away from grill.
5. Wait until the grill is cool to the touch before closing the Hood, cleaning, storing or transporting.
6. Clean your LP gas grill between uses and after extended storage periods. To maintain the condition and extend the life of your grill, the unit should be covered when stored.

Storage and Transportation

⚠ WARNING ⚠

Do not put grill in storage or travel mode immediately after use. Allow grill to cool to touch before moving or storing. Failure to do so could result in fire resulting in property damage, personal injury or death.

1. Disconnect LP Gas Cylinder from grill and store outside, in a dry, well-ventilated area, away from any sources of heat or ignition. Re-cap LP Gas Cylinder valve with the Safety Cap.
2. Cover the regulator opening with the plastic cap supplied with the grill.
3. If storing grill or before an extended period of non-use, remove Burner and wrap with aluminum foil to reduce the risk of insects entering the Burner holes. Cooking Grid and Flavor Activator may be wrapped in foil as well.
4. Store grill indoors only if the LP Gas Cylinder is disconnected from the gas grill and stored outside.
5. Before next use, remove aluminum foil and reinstall Burner, Flavor Activator, and Cooking Grid.
6. Before using the grill after periods of storage or non-use (i.e. over winter), check your LP gas grill for gas leaks, deterioration, proper assembly, and Burner obstructions.
7. Periodically check and tighten all nuts, bolts, and screws on grill.

Care and Maintenance

Cleaning the Grill

⚠ WARNING ⚠

To reduce risk of injury from laceration hazard, wear protective gloves when handling parts with sharp edges.

Drip Tray:

Remove the Drip Tray under the grill bowl after the grill has cooled completely. Scrape away food and fat residue from the Drip Tray. Empty and wash the Drip Tray with hot soapy water and a cloth.

Grill Body:

Remove excess grease and/or fat with a soft plastic or wooden scraper. Do not use steel wool or other abrasive cleaners that can scratch painted, porcelain-coated or stainless steel surfaces. It is not necessary to remove all the grease from the body. When grill is cool, wipe it down with paper towels or soft damp cloth. On painted grills, if rust appears, clean and buff the affected area with steel wool. Touch up bare metal with a high heat paint specified for barbecue grills. Follow paint manufacturer's instructions for use.

Cooking Grid/ Flavor Activator:

Clean the residue off with a baking soda and water solution. For stubborn stains, use a non-abrasive scouring powder. Do not use steel wool or other abrasive cleaners that can scratch the plated, porcelain-coated or stainless steel surfaces. This can cause foods to stick on the Cooking Grids.

All Other Cleaning:

For further cleaning, use hot soapy water and a cloth, or nylon-bristled brush only. Do not immerse the Gas Controls in water. (Avoid getting water in the Burner holes).

Burner:

Burning off the residue after cooking will keep the Burner clean with normal usage, provided the Burner is operating correctly. Clean the Burner annually, or whenever heavy build-up is found, to ensure that there are no signs of blockage (debris, insects) in the Burner portholes, the primary air inlet, or the neck of the Burner. See **How to Clean the Burner**.

How to Clean the Burners

1. Make sure the Regulator Knob is turned "Off", the grill is completely cooled and the propane cylinder is removed.
2. Carefully remove Cooking Grid and Flavor Activator.
3. To remove the Burner, first remove the Bolts that fasten the Burner to its support bracket.
4. Slide Tube burner to the left so that the end of the burner is off of the valve nozzle and inside the firebowl. Lift the venturi end of the burner up first then slide the burner out from under the electrode.
5. Use a pipe cleaner to clear inset nests of debris from the inlet hole of Main Burner.
6. Open up the Burner holes with a small nail or wire. Use a non-metallic brush to remove food particles and corrosion from the Burner surfaces.
7. Check the Electrode to see if it is loose. If so, tighten the screw holding the Electrode to maintain 3/16" gap between Electrode tip and Burner. **NOTE:** Before next step, you may wish to clean the rest of the grill. See "**Cleaning the Grill**" section.
8. After cleaning, refit the Burner. If the grill is to be stored, the Burners may be wrapped in a protective cover such as aluminum foil or plastic wrap to help keep insects out. **NOTE:** When refitting the Burner, be sure the Burner is positioned correctly. The valve nozzle should protrude inside the Venturi end of the Burner. Replace the Bolts that fasten the Burner Flange to the burner bracket.
9. Perform a Leak Test and check Burner operation after re-assembly.
10. Replace Flavor Activator and Cooking Grid.

Troubleshooting

Problem	Possible Cause	Solution
Gas leaking from LP Gas Cylinder	Mechanical failure due to rust or mishandling	Replace LP Gas Cylinder
Gas leaking between LP Gas Cylinder and Regulator connection	Improper installation, connection not tight, failure of seal on LP Gas Cylinder	Remove LP Gas Cylinder. Re-install correctly and tighten. Replace Cylinder if damaged. See "Leak Test" and "Connecting Regulator to LP Gas Cylinder" sections.
Grease fire or excessive flames above cooking surface	Too much grease build-up in Burner section	Turn off Regulator Knob and remove LP Gas Cylinder. Once fire is out and grill has cooled off, clean residual food particles and excess grease from inside firebox area, grease cup, and other surfaces.
Flashback (Fire in or around Venturi tubes)	Clogged or blocked Venturi tube	If you can safely reach the Regulator Knob, turn it to the "Off" position, then remove the LP Gas Cylinder. Once grill has cooled, clean Burner and Venturi tubes. See "How to Clean Burners" section.
Burners will not light using the ignitor	Burners not assembled correctly	See re-assembly after cleaning in "Care and Maintenance".
	Not pressing igniter in enough for spark	Push Regulator Knob in and turn counterclockwise to the "High" position. Depress the Igniter Button until a loud click is heard. Repeat until the Burner lights.
	No spark- out of place, loose, or broken	<ol style="list-style-type: none"> 1. Electrode tip is bent (making too large or small of a gap between the Electrode and burner). Bend electrode tip back to 3/16" gap to burner. (Pg. 10) 2. Tighten Electrode mounting screws. 3. Replace Igniter Wire/Electrode assembly. (Call the Customer Service Dept.)
	LP gas cylinder is empty	Purchase new 1 lb. LP Gas Cylinder
	LP cylinder is not fully attached to regulator	Tighten cylinder by hand. Do not use tools.
	Obstructions in Burners	See "How to Clean Burners" in Care and Maintenance.
	Wet Electrodes and Burners	Allow electrode to air dry, dry with clean cloth or blow dryer.
	Wire loose or disconnected	Reconnect the wire.
	Wire shorting (sparking between Igniter and Electrode)	Replace Igniter Wire/Electrode assembly. (Call the Customer Service Dept.)
Burners will not light using a match	Burners not assembled correctly.	See re-assembly after cleaning in Care and Maintenance.
	LP Gas Cylinder is empty	Purchase new 1 lb. LP Gas Cylinder.
	LP cylinder is not fully attached to regulator	Tighten cylinder by hand. Do not use tools.
	Obstructions in Burners.	See "How to Clean Burners" in Care and Maintenance.
Low flame or low heat	LP- gas in LP Gas Cylinder is low	Purchase new 1 lb. LP Gas Cylinder
Flames blow out	High or gusting winds.	Turn front of grill away from wind or increase flame height.
	Gas in LP cylinder is low.	Purchase new 1 lb. LP Gas Cylinder
Flare up	Grease build-up.	Clean grill.
	Excessive fat in meat.	Trim fat from meat before grilling.
Persistent grease fire	Grease trapped around burner system.	Turn Regulator Knob "Off" then remove the LP Gas Cylinder. Open Hood carefully and let fire burn out. After the grill cools, remove and clean all parts.

If your problem is not resolved from the information provided above, please call Customer Service at 1-866-475-5180. If you need a replacement part under warranty, a proof of purchase will be necessary.

Limited Warranty

This Smoke Hollow® grill is guaranteed against broken or damaged parts at time of purchase. All parts carry a 1-year limited warranty. Paint is guaranteed to be free of defects for 90 days except for rust, which may appear after repeated use.



This warranty does not cover damage or issues related to neglect, abuse, or modifications to the product. Repair labor is not covered.

All parts that meet the warranty requirements will be shipped at no-charge via the discretion of the Customer Service Department (ground shipments, US Mail, or Parcel Post Only). Any special handling charges (i.e. Second Day, Overnight, etc.) will be the responsibility of the consumer.

All warranty claims apply only to the original purchaser and require a proof of purchase verifying purchase date. Do not return parts to our address without first obtaining a return authorization number from our customer service.

This service is available by calling 866-475-5180, 8:30am to 4:30pm, Central Time, Monday through Friday, or write to Outdoor Leisure Products, Inc., 5400 Doniphan Drive, Neosho, MO 64850.

This warranty may give you specific legal rights that vary by state.

Outdoor Leisure Products, Inc
5400 Doniphan Drive
Neosho, MO 64850
www.olp-inc.com