



THE ART OF PRECISION™

PRECISION SERIES ***Outdoor collection***

Use and Care Guide



MODELS:

CG 30" 40" and 52"

TABLE OF CONTENTS

MESSAGE	2
WARNINGS	3
SAFETY PRACTICES & PRECAUTIONS.....	4-6
NATURAL GAS REQUIREMENTS	7
LP (PROPANE) GAS REQUIREMENTS	8
LEAK TESTING	9
LOCATING GRILL	10
BUILT IN CLEARANCES	11
ELECTRICOAL CONNECTION INSTRUCTIONS	12
FLAME HEIGHT	13
BURNER ADJUSTEMENT.....	14-15
USING GRILL/FEATURES	16-17
HELPFUL HINTS	18
REPLACING THE LIGHT.....	18
LIGHTING INSTRUCTIONS	19
USING THE ROTISSERIE	20-23
SMOKER TRAY / CHOPPING BOARDS	23
CARE AND CLEANING.....	24
BURNER REMOVAL AND CLEANING.....	25
ORFFICE CLEANING.....	25
TROUBLE SHOOTING.....	26
WIRE SHEMATICS.....	27-29
PART LIST	30-31
WARRANTY	32

Dear Valued Customer,

Congratulations on making a smart choice! You have joined an elite group of cooking enthusiasts who demand only the very best from their appliances. A Capital Cooking appliance promises years of enjoyment and maximum pleasure, allowing cooks everywhere to create culinary memories that last a lifetime.

Because of the unique features found in our appliances, we urge you to read this manual thoroughly before installation and use. And please **RETAIN THIS MANUAL FOR FUTURE REFERENCE**: it is an invaluable guide to help you better understand your Capital Cooking appliance.

Since your satisfaction is our topmost priority, please feel free to contact our service experts. You may reach us toll free at 866-402-4600, or dial the factory direct at 562-903-1168. You can fax us a list of your concerns, comments, and/or compliments at 562-903-1167, or drop us an email at customerservice@capital-cooking.com. Feel free to also write us at 13211 East Florence Avenue, Santa Fe Springs, CA 90670.

Our products are designed and proudly manufactured in America. We trust that our strict adherence to the highest quality assurance standards will provide you with years of troubled free, gourmet cooking.

Happy Cooking!

Capital Cooking Test Kitchen Specialists



WARNING!

FOR OUTDOOR USE ONLY!

WARNING!

DO NOT attempt to light grill without reading the LIGHTING INSTRUCTIONS section in this manual.

WARNING!

If the information in this manual is not followed exactly, a fire or explosion may result, causing property damage, personal injury or death. Please read the installation, operating and maintenance instructions thoroughly before use.

WARNING!

DO NOT store or use gasoline or any other flammable liquids in the vicinity of this or any other appliance.

DANGER!

If You Smell Gas

Shut off gas to the appliance

Extinguish any open flames

Open lid

If odor continues, keep away from the appliance and immediately call your gas supplier or your fire department.

WARNING!

Our grills produce intense heat with temperatures in excess of 1000 degrees. To avoid the risk of damaging (warping) the lid and causing injury, DO NOT operate the grill with all burners on HI (including rotisserie burner) and lid closed for more than 8 minutes at any given time.

- ❖ Failure to follow provided instructions or follow basic safety precautions will void all warranties.*
- ❖ Capital Cooking is not responsible for damages or injuries caused by a failure to follow instructions or basic safety practices.*

NOTE:

Children and pets should never be left alone or unattended in area where the grill is being used.

PLEASE RETAIN THIS MANUAL FOR FUTURE REFERENCE

**Tested in accordance with ANSI Z21.58b-2002/CGA 1.6 b2002 For US and Canada for LP and Natural Gas.
STANDARD FOR OUTDOOR USE ONLY.**

Check your local building codes for the proper method of installation. In the absence of local codes, this unit should be installed in accordance with the National Fuel Gas Code. No. Z223.1-1998 and National Electrical Code ANSI/NFPA No. 70-1990

SAFETY PRACTICES AND PRECAUTIONS

WARNING!

When in use, portions of this grill get hot enough to cause severe burns. Children and pets should never be left alone or unattended in an area where the grill is being used. Never allow children to sit, stand, or play on or around the grill at any time.

When properly cared for, your Precision Series™ grill will give you years of safe and reliable enjoyment. However, extreme care must be taken since the grill produces intense heat, increasing the risk of accident. When using this appliance, basic safety practices must be followed, including the following:

To reduce the risk of fire, burns, or other injury, read this Use and Care guide thoroughly. Begin by ensuring proper installation and servicing. Do not repair or replace any part of the grill unless specifically recommended in this manual. All other service must be referred to a qualified Factory Authorized Technician.

- ❖ DO NOT store items of interest to children in or around the grill. Never allow children to crawl inside the cart storage drawers or inside access doors.
- ❖ NEVER let clothing, pot holders or other flammable materials come into contact with or come too close to any grate, burner or hot surface until it has cooled. Fabric may ignite and result in personal injury.
- ❖ DO NOT heat unopened food containers. A build up of pressure may cause the container to burst.
- ❖ ALWAYS use a covered hand when opening the grill lid and only do so slowly to allow heat and steam to escape.
- ❖ NEVER lean on an open grill. When lighting a burner, always pay close attention to what you are doing. Be certain the grill has electricity connected and the igniter glows when a burner knob is turned ON
- ❖ DO NOT touch the grill burner grate, warming rack, lights or any item in the interior cavity or surrounding area of the grill when burners are on. These areas become extremely hot and could cause severe burns.
- ❖ GREASE is flammable. Let hot grease cool before attempting to handle it. Avoid letting grease deposits collect in the drip pan. Clean the grill often.
- ❖ DO NOT line drip tray or grill racks with aluminum foil. This may severely disrupt combustion airflow or trap excessive heat in the controlled area. This may result in melted knobs and/or igniter, damage to the lighting system and may cause excessive heat on the control panel area.
- ❖ TAKE PRECAUTION when cleaning the grill. To avoid steam burns do not use a wet sponge or cloth to clean the grill while it is hot. Some cleaners produce noxious fumes or can ignite if applied to a hot surface.

SAFETY PRACTICES AND PRECAUTIONS

- ❖ BE SURE all control knobs are in the OFF position and grill is cool prior to using any aerosol cleaner on or around the grill. The chemical that produces the spraying action could, in the presence of heat, ignite or cause metal part to corrode.
- ❖ ALWAYS use dry potholders: moist or damp potholders on hot surfaces may cause steam burns. Do not use a towel or bulky cloth in place of potholders.
- ❖ DO NOT let potholders touch hot portions of the grill rack or burner.
- ❖ DO NOT use the grill to cook excessively fatty meats or products that promote flare-ups.
- ❖ NEVER use the grill without the drip tray in place and pushed all the way to the back of the grill. Grease could leak downward and produce a fire or explosion hazard.
- ❖ DO NOT operate the grill under unprotected combustible construction. Use only in a well ventilated area. DO NOT obstruct the flow of combustion and ventilation air.
- ❖ DO NOT use the grill in buildings, garages, sheds, breezeway or other such enclosed areas. This unit is for Outdoor Use Only!
- ❖ KEEP ALL electrical cords away from the heated areas of the grill.
- ❖ BEGIN by ensuring proper installation and servicing. Follow the installation instructions provided with this product. Have your grill installed by a qualified technician. Have the installer show you where the gas supply shut off valve is located so you know where to shut off the gas to the grill in an emergency.
- ❖ IF YOU SMELL GAS, your installer has not done a proper job of checking for leaks. If the connections are not perfectly sealed, you can have a small leak and therefore a faint gas smell. Finding a leak is not a “do-it-yourself” procedure. Some leaks can only be found with the burner control in the “ON” position. This must be done only by a qualified technician.

IMPORTANT SAFETY NOTICE REGARDING LP TANKS:

Certain Liquid Propane dealers may fill liquid propane cylinders for use in the grill beyond cylinder filling capacity. This “Overfilling” may create a dangerous condition.

“Overfilled” tanks can build up excess pressure. As a safety device, the tank’s pressure relief valve will vent propane gas vapor to relieve this excess pressure. This vapor is combustible and therefore can be ignited. To reduce this danger, you should take the following safety precautions:

- 1. When you have your tank filled, be sure you tell the supplier to fill it to no more than $\frac{3}{4}$ (75%) of its total filling capacity.**
- 2. If you own or use an extra tank, or have a disconnected tank, you should never store it near or under the grill unit or heat box, or near any other ignition or heat source.**

SAFETY PRACTICES AND PRECAUTIONS

NEVER store a spare LP cylinder under or near the unit.

NEVER fill the tank beyond $\frac{3}{4}$ full.

A fire causing death or serious injury may occur.

Never use a dented or rusty LP tank.

A NOTE ON CLOTHING:

For personal safety, wear proper apparel. Loose fitting garments or sleeves should never be worn while using this appliance. Some synthetic fabrics are highly flammable and should not be worn while cooking.

A NOTE ON COOKWARE:

Only certain types of glass, heat-proof glass ceramic, earthenware, or other glazed utensils are suitable for grill use. Other types of materials may break with sudden temperature changes. Use only on low or medium heat setting according to the manufacturer's directions.

WARNING:

Spiders and insects can nest in the burners of this and any other grill, and cause the gas to flow from the front of the burner. This is a very dangerous condition that can cause a fire to occur behind the valve panel, thereby damaging the grill and making it unsafe to operate.

WARNING:

Keep the area surrounding the grill free from combustible materials, trash, combustible fluids and vapors such as gasoline or charcoal lighter fluid. DO NOT obstruct the flow of combustion and ventilation air.

WARNING:

NEVER use the grill in windy conditions. If located in a consistently windy area (oceanfront, mountaintop, etc.) a windbreaker will be required. Always adhere to specific clearances listed.

CALIFORNIA PROPOSITION 65 WARNING: The burning of gas cooking fuel generates some by-products which are on the list of substances which are known by the State of California to cause Cancer or reproductive harm. California law requires businesses to warn customers of potential exposure to such substances. To minimize exposure to these substances, always operate this unit according to the Use and Care Guide, and ensure you provide good ventilation when cooking with gas.

NATURAL GAS REQUIREMENTS

Verify the type of gas to be used, either LP (propane), or Natural gas, and make sure the marking on the appliance rating plate agrees with that of the supply.

The rating plate is located under the drip tray of the grill. Never connect an unregulated gas line to the appliance.

An installer supplied gas shut-off valve must be installed in an easily accessible location. All installer-supplied parts must conform to local codes, or in the absence of local codes, with the National Electrical Codes, ANSI/NFPA 70-1990, and the National Fuel Gas code, ANSI Z223.1-1998.

All pipe sealants must be an approved type and resistant to the actions of LP gases. Never use pipe sealant on flare fittings. All gas connections should be made by a qualified technician and in accordance with local codes and ordinances.

In the absence of local codes, the installation must comply with the National Fuel Gas code, ANSI Z223.1-1998. Gas conversion kits are available from the factory. When ordering gas conversion kits, please have the model # and gas type (natural or LP) available from your grill.

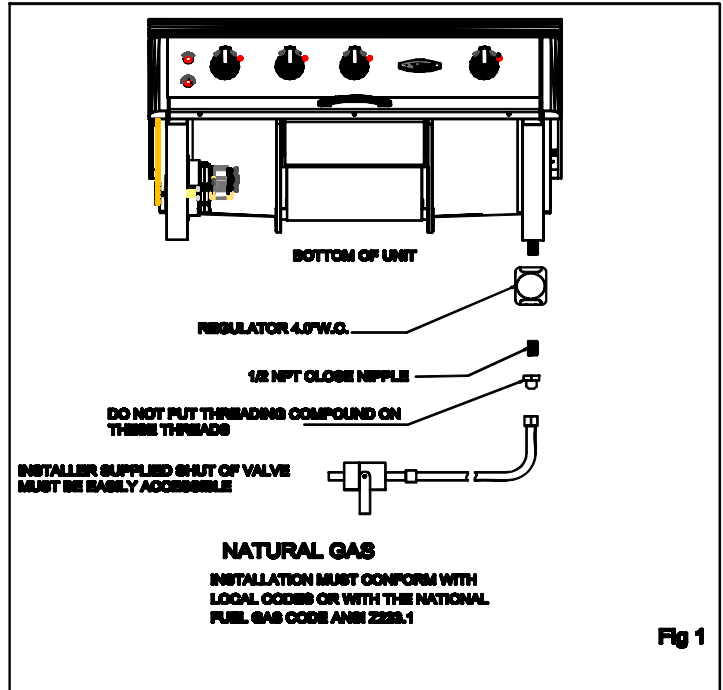

TOTAL GAS CONSUMPTION OF THE GRILL WITH ALL BURNERS ON "HI":

Models:

CG30 – 2 BURNERS + Rotisserie, 63,000 BTU/Hr
CG40 – 3 BURNERS + Rotisserie, 90,000 BTU/Hr
CG52 – 4 BURNERS + Rotisserie, 126,000 BTU/Hr

The appliance and its individual shut-off valve must be disconnected from the supply piping system during any pressure testing of that system at test pressure in excess of ½ PSIG (3.5kPa). The appliance must be isolated from the gas supply piping system by closing its individual shut-off valve during any pressure testing of the gas supply piping system at test pressures equal to or less than ½ PSIG (3.5kPa). The installation of this appliance must conform with local codes or in the absence of local codes, with the National Fuel Gas Code, ANSI Z223.1-1998 installation in Canada Must be in accordance with standard Can 1-b149.1 and /or.2 (installation code for gas burning appliances and local codes).

NATURAL GAS HOOKUP:

Connection: ½" NPT male with 3/8" flare adapter. Operating Pressure: 4.0" w.c., Supply Pressure: 5" to 14" w.c. If in excess of 14" W.C. a step down regulator is required. Check with your local gas utility company or with local codes for instructions on installing gas supply lines. Be sure to check on type and size or run, and how deep to bury the line. If the gas line is too small, the grill will not function properly. Any joint sealant used must be an approved type and be approved type and be resistive to the actions of LP gases.

TO HOOK-UP THE FITTINGS SUPPLIED WITH THE GRILL:

Assemble as shown (Fig 1). Use threading compound on male threads only. Do not use threading compound on the male end of the 1/2 NPT to 3/8 flare adapter. Use second pipe wrench to hold the grill inlet pipe to avoid shifting any internal gas line of the grill Ensure that the regulator arrow points in the direction of the gas flow toward the unit, away from the supply. Do not forget to place the installer supplied gas valve in an accessible location.

LP GAS REQUIREMENTS

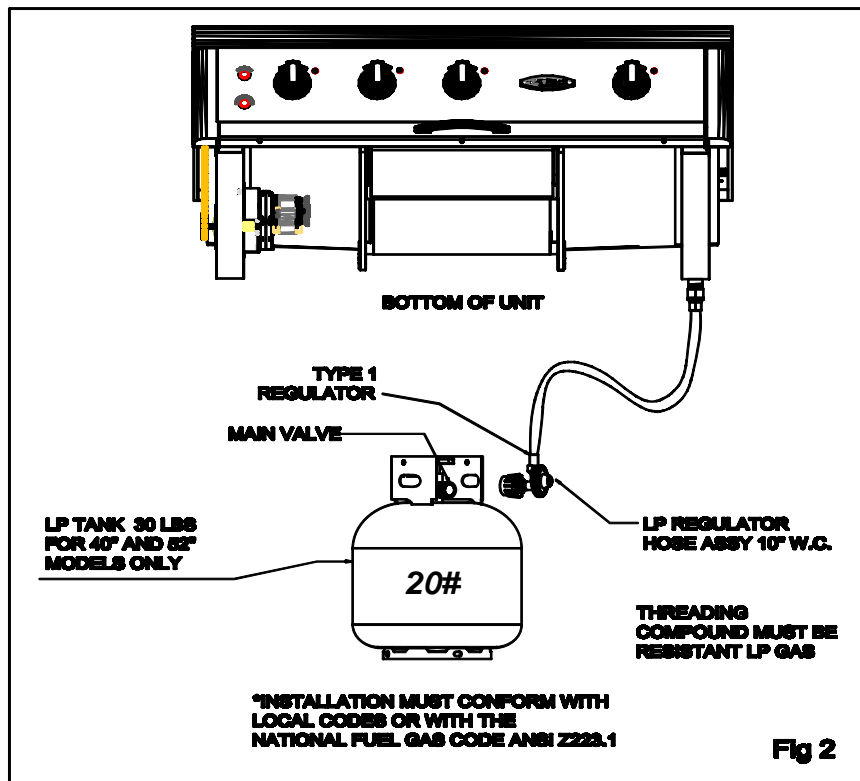

**40" AND 52" CART MODELS □
WILL ACCOMMODATE A 20# VERTICAL
OR 30# HORIZONTAL TANK**



NOTE: When an LP unit is directly connected to in-house LP system, a step down regulator *MUST* be used to reduce the supply pressure to a max. 14" W.C. and min. 11" W.C. to the grill regulator.

Grills that have orifices for use with LP gas come equipped with capacity hose/regulator assembly for connection to a standard 30lb. cylinder (Type 1). The LP tank is not included.

Connection: 1/2" NPT MALE WITH A 3/8" Flare adapter (included). LP hose with a quick disconnect and fittings are included. Operating Pressure: 10.0" W.C.

To connect the LP regulator/hose assembly to the tank/valve assembly, first make sure the main valve on the tank is completely closed. Although the flow of gas is stopped when the Type 1 system is disconnected as part of its safety feature you should always turn off the LP tank main valve (Fig 2) after each use and during transport of the tank or unit. Insert the regulator inlet into the tank valve and turn the black coupler clockwise until the coupler tightens up. Do not over-tighten the coupler. Turn the main tank valve "ON" and turn the burner control valve on the unit to the "HI" position for about 20 seconds to allow the air in the system to purge before attempting to light the burners.

LP TANK REQUIREMENTS:

A dented, damaged or rusty LP tank may be hazardous and should be checked by your LP supplier. Never use a cylinder with a damaged valve. Always check for leaks after every LP tank change. The LP gas cylinder must be constructed and marked in accordance with the specifications for LP gas cylinders of the U.S. Department of Transportation (DOT) and designed for use with a Type 1 system only. Do not change the regulator/hose assembly with a standard 510 POL tank/valve assembly. The cylinder must be provided with a shut off valve terminating in an LP gas supply cylinder valve outlet specified, as applicable for connection Type 1. If the appliance is stored indoors, the cylinder must be disconnected and removed from the appliance. Cylinders must be stored outdoors in a well-ventilated area out of the reach of children.

LEAK TESTING

GENERAL:

Although all gas connections on the grill are leak tested at the factory prior to shipment, a complete gas tightness check must be performed at the installation site due to possible mishandling in shipment, or excessive pressure unknowingly being applied to the unit. Periodically check the whole system for leaks, or immediately check if the smell of gas is detected.

BEFORE TESTING:

Do not smoke while leak testing. Extinguish all open flames. Never leak test with an open flame. Make a soap solution of one part liquid detergent and one part water. You will need a spray bottle, brush, or rag to apply the solution to the fittings. For LP units, check with a full cylinder. The valve panel must be removed to check the valves and fittings. First, remove the knobs. Next, pull the drip pan tray forward slightly to access the screws that affix the front panel to the unit. Using a screwdriver, remove the screws. Finally, gently pull the panel downward and out, making sure that you are not pulling out the wires. Remove the screws which hold the service panel in place.

TO TEST:

Make sure that all control valves are in the "OFF" position. Turn the gas supply "ON". Check all connections from the supply line, or LP cylinder up to and including the manifold. Soap bubbles will appear where a leak is present. If a leak is present, immediately turn off gas supply, tighten any leaking connections, turn gas on, and recheck. Check all the gas connections at the base of the control valves where they screw into the manifold pipe.

To check rotisserie burner and safety valve, the burner must be lit, then leak test the connections located behind the service panel. If you cannot stop a gas leak, turn off the gas supply and call your local company, or the dealer from whom you purchased the grill. Only those parts recommended by the manufacturer should be used on the Grill. Substitution can void the warranty.

Do not use the grill until all connections have been checked and do not leak.

Check all gas supply fittings for leaks before each use. It is handy to keep a spray bottle of soapy water near the shut-off valve of the gas supply valve. Spray all the fitting. Bubbles indicate leaks. (See Fig 3 and 4)

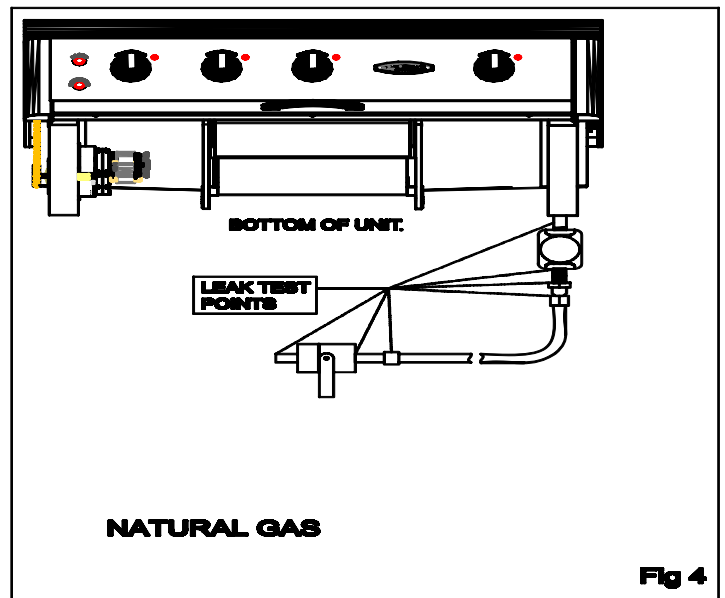
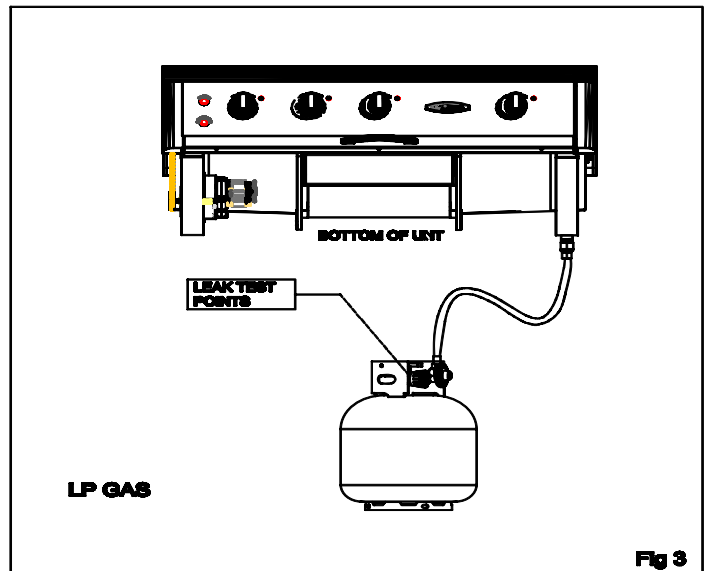

LOCATING GRILL/ BUILT IN CLEARANCES

GENERAL:

The grill is designed for easy placement into non-combustible masonry enclosures. For non-combustible applications the grill drops into the opening shown in (Fig 5) and hangs from its side flanges. A deck is not required to support it from the bottom.

LOCATION:

When determining a suitable location, take into account concerns such as exposure to wind, proximity to traffic paths and keeping any gas or electrical supply lines as short as possible. Locate the grill only in a well-ventilated area. Never locate the grill inside a building garage, breezeway, shed or other such enclosure area without an approved ventilation system. During heavy use, the grill will produce a lot of smoke. Ensure there is adequate area for the smoke to dissipate.

IMPORTANT:

A minimum of 12" clearance from the side and a minimum of 12" from the back must be maintained from the grill above and below the cooking surface to adjacent vertical combustible construction. See (Fig 6) on the next page.

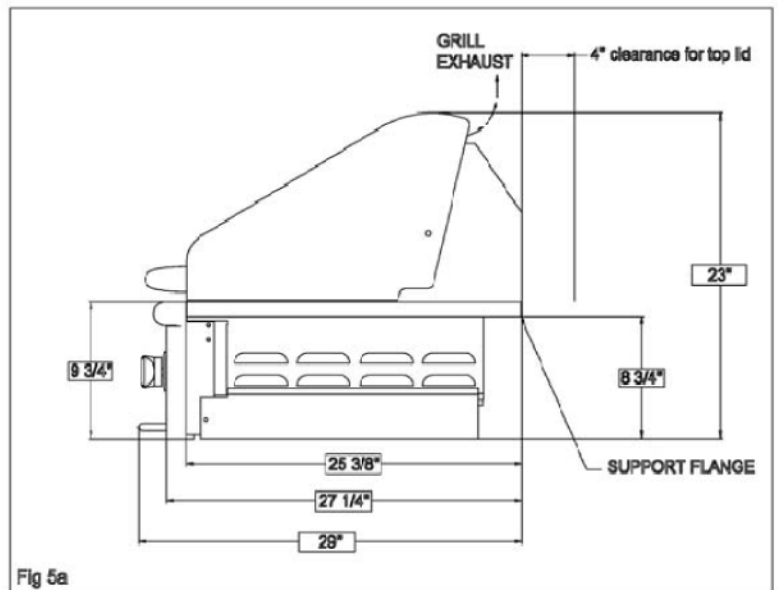
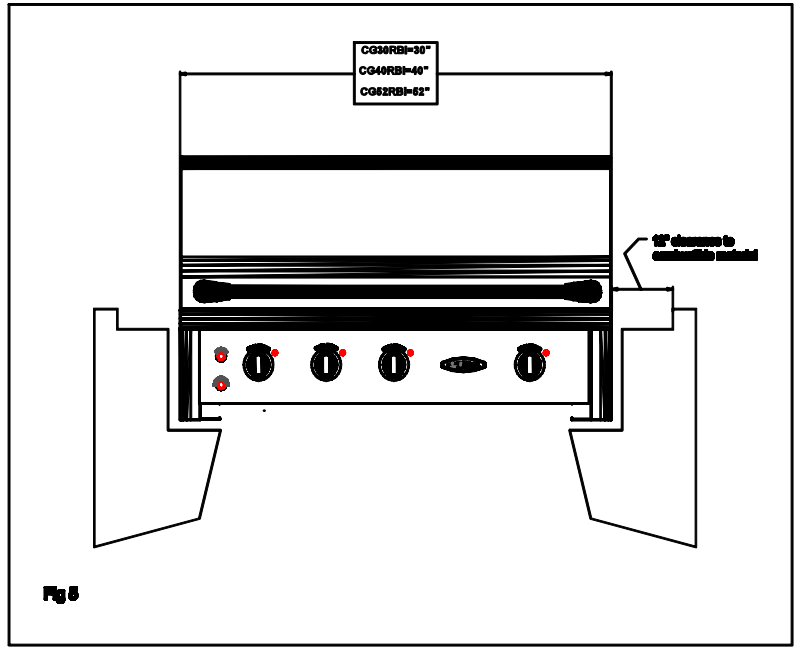

BUILT IN CLEARANCES

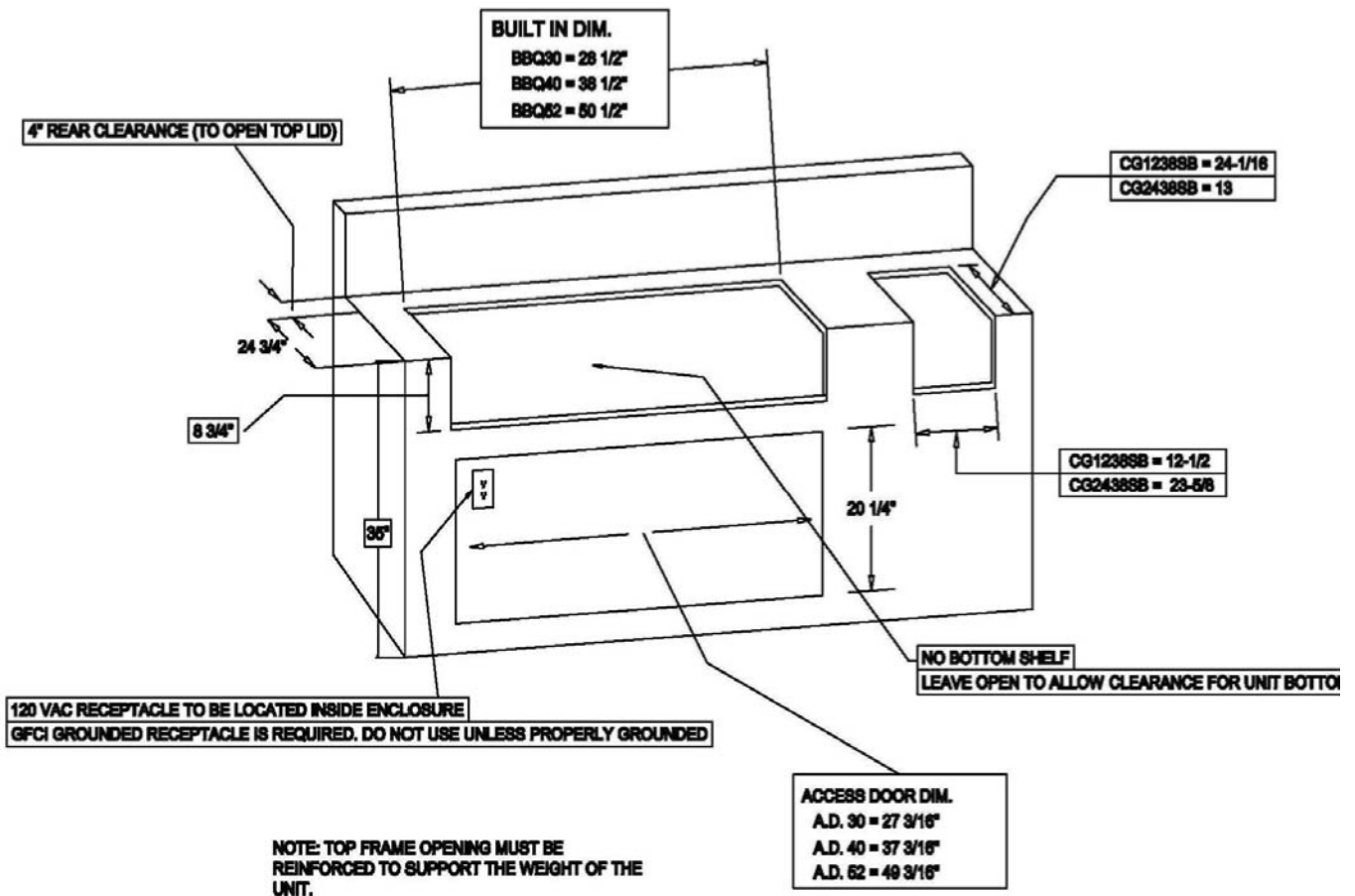

ELECTRICAL CONNECTION INSTRUCTIONS

ELECTRICAL CONNECTION

Use an approved extension cord, rated for 120 VAC, 15 Amps, to connect power to the transformer box. Make sure there are no cuts in the insulation to prevent electric shock. A certified GFCI receptacle must be installed and used for safety. The receptacle must be properly grounded.

This appliance is equipped with a three-prong (grounding) receptacle for your protection against shock hazard and should be plugged directly into a properly grounded GFCI receptacle using an appropriate extension cord. Do not cut or remove the grounding prong from the extension cord.

NOTE: The use of a qualified technician/electrician is recommended for all electric connection.

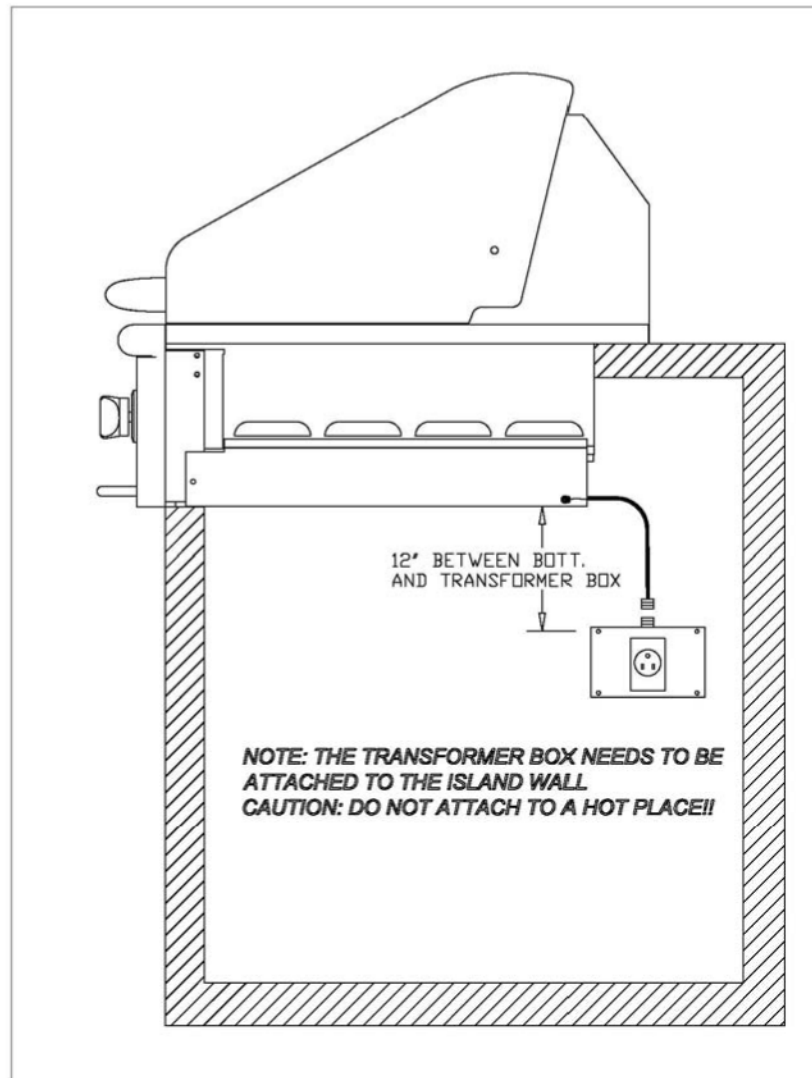

FLAME HEIGHT

GRILL BURNER FLAME HEIGHT:

To access the grill burner air shutters, first remove the grill racks and radiant trays, Lift the burner out as described in the section BURNER CLEANING. With a screw driver, loosen the set-screw on the air shutter. Light the burner and adjust according to the directions below. Access for the side burner air shutters is through the top after removing the top burner grate and aeration pan assembly (see Fig 7).

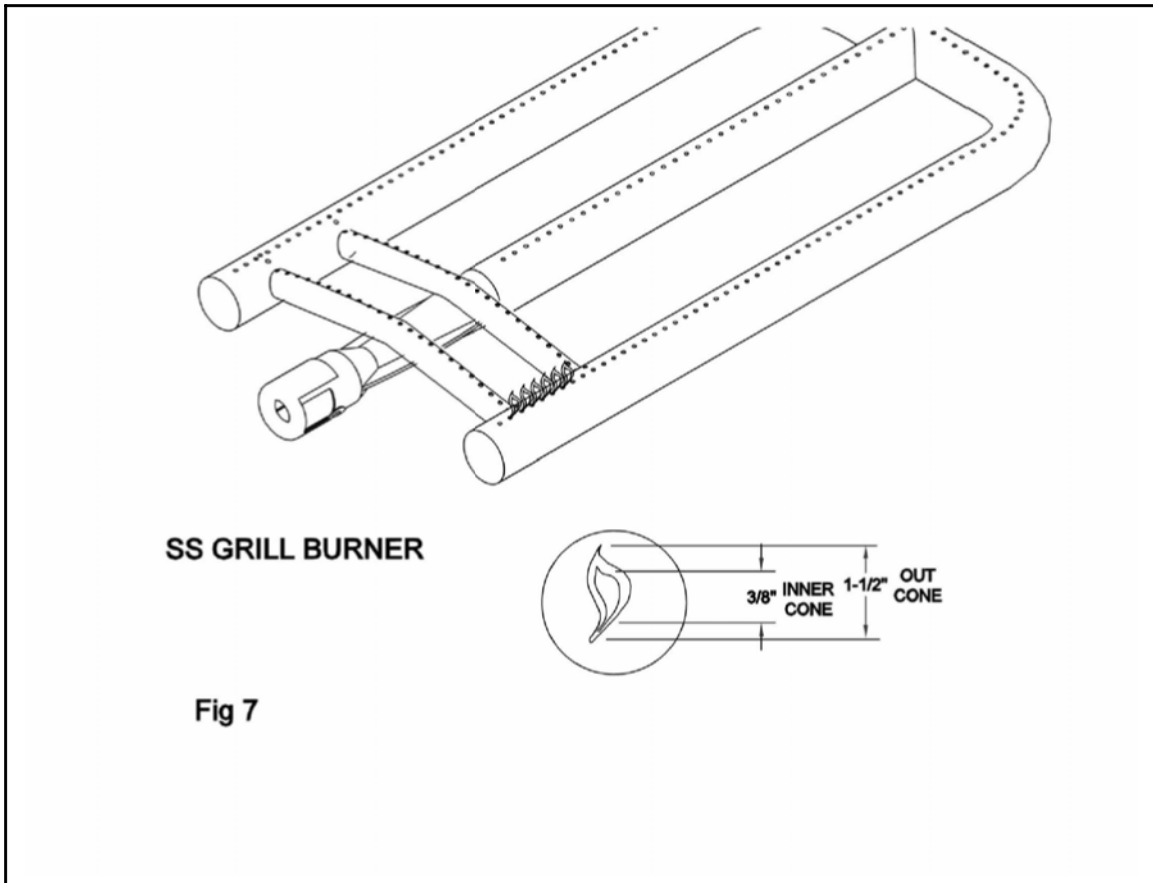

BURNER ADJUSTMENTS

BURNER AIR ADJUSTMENT:

To Adjust Tube Burner Flames:

1. Be careful as the burner may be very hot!
2. If the flame is yellow, indicating insufficient air, adjust the air shutter counter clockwise to allow more air to the burner.
3. If the flame is noisy and tends to lift away from the burner, indicating too much air, turn the air shutter clockwise
4. Once adjusted, turn the burner off, lock the air shutter in position and reverse steps to reassemble.

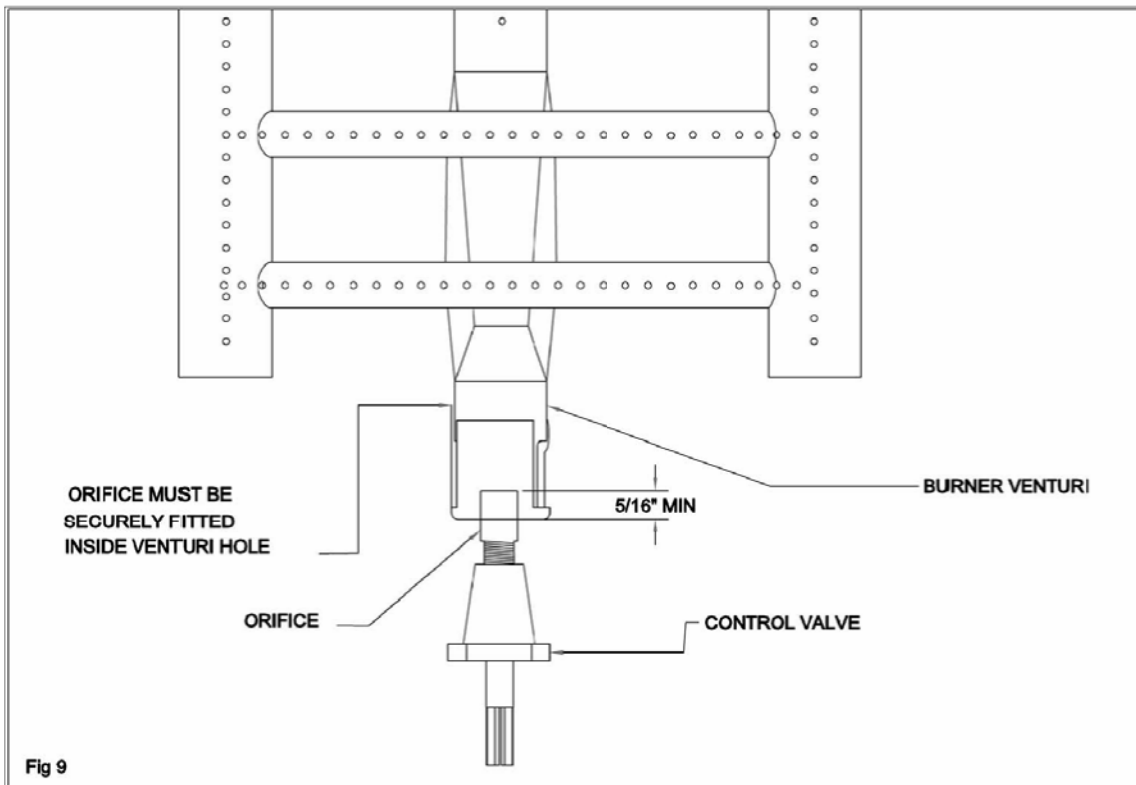

BURNER ADJUSTMENTS (continued)

To Adjust:

(Tools Required: Pliers, Flat Head Screwdriver)

1. Light the burner.
2. Turn the control knob to the lowest setting (all the way counter clockwise).
3. Remove the knob.
4. While holding the valve shaft with the pliers, insert a thin flat-Head screwdriver into the shaft and while viewing the burner adjust to a minimum stable flame. (Fig 10)

WARNING: IMPORTANT!

Before lighting, inspect the gas supply piping or hose prior to turning the gas "ON". If there is evidence of damage or excessive wear, it must be replaced prior to use.

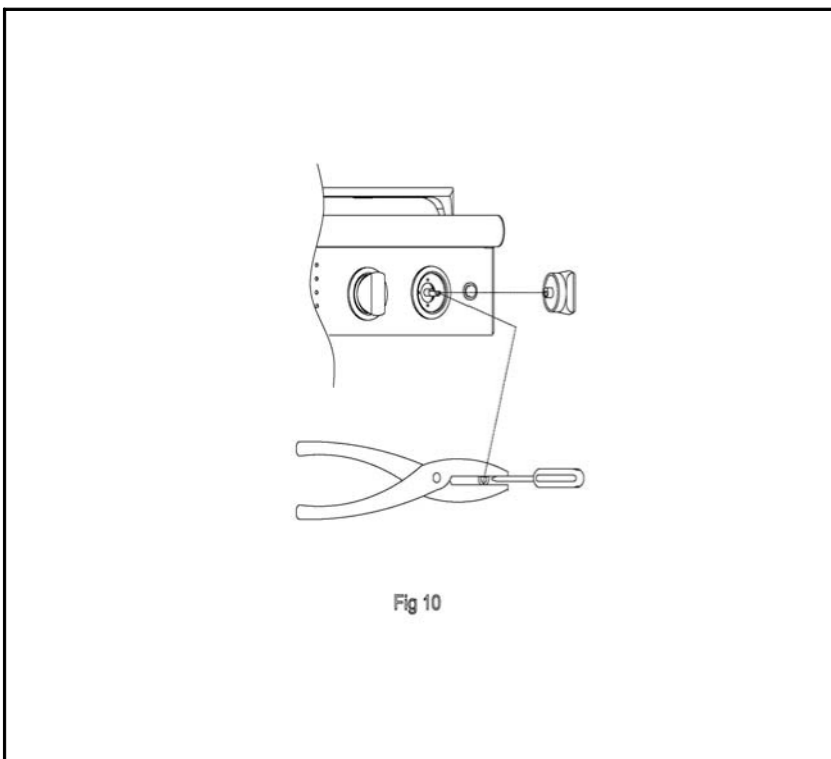

Fig 10

USING THE GRILL/FEATURES

USING THE GRILL:

Each grill section consists of a large stainless steel “W” shaped burner or a Sear-Perfect Zone infrared grill burner, stainless heat baffles a series of hybrid stainless steel and ceramic radiants. Each “W” shaped burner is rated at 25,000 BTU/Hr. Above the burners are hybrid stainless/ceramic radiants which provide even heat, reduce flare-ups and protect the burner ports from blockage due to spills.

PRECISION “W” BURNER:

The Precision Series™ gas grills feature the Capital exclusive “W” shaped burners. These are constructed from heavy gauge 304 stainless steel. They are rated at 25,000 BTU/HR. Due to their large size they offer greater coverage across entire grill surface, which means no more cold spots! Our 30 inch 40 inch, and 52 inch models also feature an infrared Burner/s

A TRUE RADIANT SYSTEM:

Capital’s new Precision Series grills utilize a revolutionary “hybrid” radiant system that takes the best features of a stainless steel radiant and combines them with the characteristics of a ceramic radiant, while eliminating the weaknesses of each. These radiants prevent flames from directly contacting cooking food and prevent uneven temperatures. They suppress flare-ups considerably. This radiant system also enhances flavors by burning drippings from the cooking food and basting the food in the smoke of the drippings.

The unique design of the stainless steel encased ceramic radiant elements allows the burner flames to directly heat the ceramics for a near instantaneous heat transfer over the entire cooking area. The ceramics absorb and then evenly distribute heat which eliminates hot spots and reduces flare ups. By retaining heat, the ceramics also reduce the amount of gas required to maintain a hot grill.

The stainless steel protects the ceramic elements from breakage, common with ceramic materials, while containing them for ease of handling and use. Each radiant module is removable and reversible to allow self cleaning after heavy soiling.

The new Capital hybrid radiant combines the durability and design flexibility of a stainless steel radiant with all the benefits modern ceramic materials can provide.

BBQ’ING or GRILLING ? YOUR CHOICE!

Did you know there is difference between BBQ’ing and Grilling? BBQ’ing requires slow cooking foods with low to moderate heat, and grilling requires intense searing heat to lock in the juices. The Precision Series™ is the most versatile grill on the market, because it allows you to do both simultaneously. Our main “w” burners allow for controlled heat, slow cooking vegetables, fish and poultry over a long period of time to ensure maximum results while the Sear-Perfect Zone™ allows rapid, intense cooking that locks in juices. But turn down the heat and you can slow cook your food to perfection. Cooked either way, the wonderful results will speak for themselves.

WHAT’S YOUR FAVORITE CHANNEL?

Our 40 and 52 inch grills feature a superior grill rack system that channels grease and allows it to flow into special seep holes and down to the drip tray for easy clean-up. Our channel grate are constructed of a heavy gauge stainless steel; which are electro-polished for a brilliant finish. We recommend that you clean the grill racks after each use to maintain their superior grease channeling design. Discoloration after first use is normal. Our 30” Grills utilize traditional rod grates but Channel Grates are available as an accessory. Please ask your dealer for details.

USING THE GRILL/FEATURES

HIT THE LIGHTS!

Each model in the Precision Series™ line features night-lights. There are located on the rotisserie panel and point downward to illuminate the entire grilling surface. Each light is rated at 20 W and is operated by a switch located on the front panel. Say goodbye to clunky night-lights and cumbersome extension cords. Now you can grill all night till the break of dawn and beyond.

Go on, “Hit the Lights!”

REPLACEMENT OF REGULATOR AND HOSE:

The pressure regulator and hose assembly supplied with the unit must be used. The replacement pressure regulators and hose assembly must be the type specified by the manufacturer. Do not use the grill if the odor of gas is present. If the unit is LP, screw the regulator into the tank and leak check the hose and regulator connections with a soap and water solution before operating the grill. Turn all knobs to “OFF” then turn on the gas supply. If LP, is there gas in the tank? Always keep your face and body as far away as possible from the grill when lighting.

--DO NOT leave the grill unattended while cooking.

--KEEP a spray bottle of soapy water near the gas supply valve and check the connections before each use.

--DO NOT attempt to “Light” the grill if odor of gas is detected.

--WAIT five minutes before relighting a hot grill.

IMPORTANT: Using the Grill

Grilling requires high heat for searing and proper browning. Most foods are cooked at the ‘MEDIUM’ heat setting for the entire cooking time. However, when grilling large pieces of meat or poultry, it may be necessary to turn the heat to a lower setting after the initial browning. This cooks the food through without burning the outside. Foods cooked for a long time or basted with a sugary marinade may need a lower setting near the end of the cooking time.

- ❖ Check to be certain the drip pan and grease tray are in place.
- ❖ Light the grill burners using the instructions provided in this Use and Care Guide. Lighting Instructions are found on the inside of the drip pan tray sleeve.
- ❖ With the grill lid open, turn the control knob to “HI” to light. Preheat the grill for 5 to 10 minutes.
- ❖ Place the food on the grill racks and cook to the desired doneness. Adjust heat setting, if necessary. The control knob maybe set to any position between “HIGH” and “LOW”. Note that most BBQ’ing is performed using a medium to low flame. Adjust the flame to suit your food requirements.
- ❖ Allow the grill to cool and clean the grates, drip pan and grease tray after each use.

Note: If using LP gas, your preheat time may be shorter than recommended. To prevent overcooking or burning, you may want to lower heat settings.

HELPFUL HINTS

A FEW WORDS ON MEAT:

The doneness of the meat, whether rare, medium or well done, is affected to a large degree by the thickness of the cut. Expert chefs say that it is impossible to have a rare doneness with a thin cut of meat. The cooking time is affected by the kind of meat, the size and shape of the cut, the temperature of the meat when cooking begins, and the degree of doneness desired. When defrosting meats it is recommended that it be done overnight in the refrigerator as opposed to a microwave. This in general yields a juicier cut of meat. Use a spatula instead of tongs or a fork to turn the meat. A spatula will not puncture the meat and let the juices run out. To get the juiciest meats, and seasoning or salt after the cooking is finished and turn the meat only once (juices are lost when the meat is turned several times.) Turn the meat just after the juices begin to bubble to the surface. Trim any excess fat from the meat before cooking. To prevent steaks or chops from curling during cooking, slit the fat around the edges at 2-inch intervals.

A FEW WORDS ABOUT FLARE-UPS

Flare ups are unavoidable and usually relate directly to the type of meat being cooked and its fat content. Our Precision Series Barbecues utilizes hybrid stainless steel/ceramic wave shaped radiants that reduce flare ups considerably as compared to all stainless or all ceramic Radiants used by other manufacturers. Always trim excessive fat and use marinades sparingly.

REPLACING THE LIGHTS



FIG A



FIG B



FIG C

1. Carefully wedge a flat tipped screwdriver between the back glass of the light cover and the rotisserie back panel as shown in Fig A.
2. Using extreme care, push screwdriver back and catch the light cover with opposing hand as shown in Fig B.
3. Access the bulb and carefully pull to remove. Fig C.
4. Replace bulb with a new one as shown in Fig D.



FIG D

LIGHTING INSTRUCTIONS

Lighting The Grill Burner:

Note: Open the grill lid before lighting. Turn all knobs to “OFF”. Turn the main gas supply on. If you smell gas, shut-off gas-supply and call for service.

Turn the selected burner knob to “HIGH.” A glow will be visible from the burner igniter during ignition and will remain ON while the burner is in use. This is normal and will re-light the burner if the flame goes out and there is gas available. If the burner does not light within 4 to 5 seconds, turn knob “OFF” and wait 5 minutes before trying again to allow any accumulated gas to dissipate.

Match or Butane Lighting Method:

CAUTION: Keep your face and hands as far away from the grill as possible when manually lighting burners.

In the event of a power failure or if a burner igniter is damaged, the unit can still be used. If an attempt has just been made to ignite a burner, wait 5 minutes and follow the procedure listed below:

1. Prior to lighting, locate the “ignition areas” which are the igniter shields for the burner to be lit. The shields are small stainless steel boxes below the grates.
2. Separate two grates above the desired burner as shown in Fig. 12 to allow access to the ignition area
3. Using the match holder provided (shown below), located inside the drip tray drawer area, securely place a match in the clip side of the holder.
4. Ignite the match and insert it between the separated grates. Place the flame as close as possible to the igniter shield of the desired burner.
5. Push and turn the control knob for the associated burner to “HIGH”. If the burner does not light in 4 seconds, turn the knob “OFF”, wait 5 minutes to allow gas to dissipate and try again (Fig. 11 and Fig. 12).
6. Monitor manually lit burners. If the flame is extinguished they will not automatically reignite. If a flame is extinguished while in use, turn the burner OFF and wait 5 minutes before relighting to allow gas to dissipate.



**MATCH HOLDER
LOCATION**



FIG 11



FIG 12

USING THE ROTISSERIE

Lighting the Rotisserie Burner:

NOTE: The safety valve on all Precision Series™ rotisserie sections is included in the main burner valve. No separate safety button is necessary to operate the rotisserie safety feature.

NEVER USE ROTISSERIE BURNER WHEN GRILLING SURFACE IS USED.

The location of the rotisserie burner makes it more susceptible to strong wind conditions than the protected grill burners. For this reason you should avoid operating the rotisserie during windy conditions. As an added safety feature we've equipped the burner with an automatic safety valve that will not allow gas to flow to the rotisserie burner unless the following conditions are present with the knob on.

- ❖ The safety valve button is pressed and held down.
- ❖ The safety valve thermocouple has been sufficiently heated to keep safety valve open.

Open the lid. Push and turn the control valve to "HI" and wait 5 seconds. The igniter will glow brightly to ignite the burner. Hold the knob pressed in until the rotisserie burner lights. Once lit keep knob pushed in and held in position for 10 seconds. **DO NOT** let go of the control knob once burner is lit. The burner will not stay lit unless it is hot. After 10 seconds, release the knob and set the knob to the desired setting. If the burner does not light within 4 to 5 seconds, release the safety valve button and turn the control knob "OFF" and wait 5 minutes before trying again.

- ❖ If relighting a hot burner, wait 5 minutes.
- ❖ Never leave the control knob ON if rotisserie is not in use.
- ❖ Never light the bottom burners while the rotisserie burner is lit.



FIG.A

Manual Lighting:

To manually light the rotisserie, place a lighter flame near the tip of the thermocouple as shown in Fig. 13 Turn the control knob to "HI". Hold the safety valve button in for 10 seconds or until the burner remains lit. Once lit, turn control knob to desired setting. If the burner does not light within 4 to 5 seconds, release the safety valve button and turn the control knob to "OFF" and wait 5 minutes before trying again.

USING THE ROTISSERIE (continued):



NOTE: The grill rotisserie system is designed to cook items from the back using infrared heat. The location of the burner allow the placement of the rotisserie basting pan (included) beneath the food to collect juices and drippings for basting and gravy. To flavor the contents of the basting pan you can add herbs, onion, garlic, or spices. Hams are especially good with the addition of pineapple slices and brown sugar to basting pan. The rotisserie burner is an infrared type that provides intense, searing radiant heat. Preferred by chefs over other methods, this intense heat is magnificent for searing in the natural juices and nutrients found in quality cuts of meats.

Once lit, the rotisserie burner will reach cooking temperatures in about 1 minute. the orange/red glow will even out in about 5 minutes. The rotisserie is equipped with metal gears and is capable of turning up to a 50 lb cut of meat or poultry.

PREPARATION

Recommended Equipment:

Butcher string, scissors, broiler pan (bottom only), pliers, instant read thermometer, foil, and hot pads.

Work Area:

Allow enough space to accommodate food and rotisserie rod assembly in a clean environment.

Meat Preparation:

Tie meat with butcher string or dental floss in three areas. Buy a roast that is equally balanced from top to bottom in size. The meat will cook more evenly while on the rotisserie. For poultry, tie wings and legs to the body using dental floss or butcher string to prevent flopping around.

- ❖ Determine the center placement for the food, put 1st prong on Rod, turn "L" shaped screw to tighten.
- ❖ Center tied meat/poultry on rod and place second prong. Turn "L" shaped screw to tighten.
- ❖ Pick up rod, rotate it to check for balance, If not balanced, adjust prongs and food to balance it. Take pliers and tighten the "L" shaped screw on both sides of the prong.
- ❖ Remove grates and warming rack on the grill. Place bottom portion of broiler pan on radiant trays to catch meat drippings.
- ❖ Place prepared rod into motor socket, lay across to other side in groove/ball bearings and begin.

USING THE ROTISSERIE (continued:)



WARNING! Never have the grill burners (bottom burners) ON during rotisserie cooking. It will burn your meat and make it extremely dry. Use either grill or rotisserie at a time.

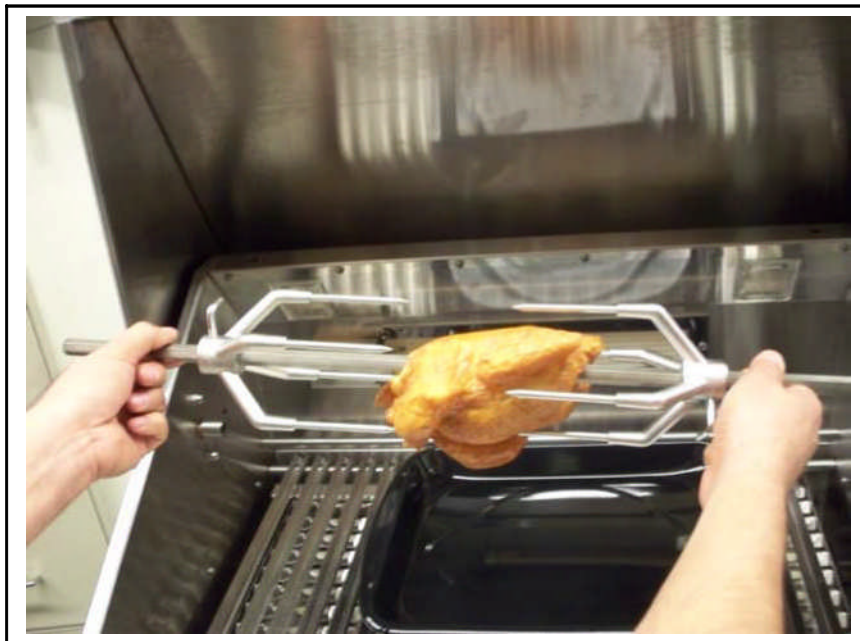

USING THE ROTISSERIE (continued):

WARNING:

Keep hands and face away from front of burner! STAND TO THE SIDE WHEN LIGHTING. ONCE LIT MOVE HAND AWAY QUICKLY!

WARNING:

Electrical Grounding Instructions:

This appliance is equipped with a three-prong (grounding) receptacle for your protection against shock hazard and should be plugged directly into a properly grounded GFCI receptacle using an appropriate extension cord. Do not cut or remove the grounding prong from the extension cord.

The appliance must be electrically grounded in accordance with local codes or, in the absence of local codes, with the National Electrical Code, ANSI/NFPA 70-1990.

THE SMOKER BOX (Accessory)

WARNING! ALWAYS use safety mittens when handling a smoker tray in use.

1. When cool, lift the smoker box lid and add just enough water so that it lines the bottom of the internal tray.
2. Load a generous amount of flavored or unflavored smoker chips in tray.
3. Place smoker tray in any desired position on grill. For best results place directly above main grill burner.
4. Light burner beneath smoker tray.
5. Close lid and wait 5 minutes.
6. Check periodically to see if smoker tray is achieving the desired results.
7. Add more smoker chips if necessary, but exercise EXTREME CAUTION when opening and closing the smoker lid when grill burners are in use.

BIRCH WOOD CHOPPING BOARD (Accessory)

WARNING! Moisture may expand the chopping board so that it becomes warped and unable to fit comfortably in the side tray shelves. NEVER leave a chopping board out overnight or in the presence of excessive moisture or humidity. ALWAYS store the chopping blocks in a cool dry place after each use.

CARE AND CLEANING

IMPORTANT!

Stainless steel tends to rust in presence of chlorides and sulfides, especially in coastal areas. To improve rust prevention, wash all stainless steel surfaces every 3-4 weeks with fresh water and stainless steel cleaner

Grill Grates:

(Recommended Equipment: Brass Bristle BBQ Brush, Mitts, Bowl of Tap Water)

The easiest way to clean the grill grates is immediately after cooking is completed and after turning off the flame. Wear a BBQ mitt to protect your hand from the heat and steam. Dip a fine brass brush in tap water and scrub the hot grill. Dip the brush frequently in the bowl of water. The steam created from the contact with the hot grill assists the cleaning process by softening any food particles. The food particles will fall onto the radiant tray and burn off or fall into the drip pan.

Drip Pan Grease Tray:

The grease trays will collect grease from the grill section. The internal trays are dishwasher safe and we recommend that you first clean off the excess residue and debris before washing.

Allow the pan and its contents to cool before attempting to clean.

Clean grease from the pan often to avoid the possibility of a grease fire.

Radiant Trays :

---Warning! Allow the grill to sufficiently cool before handling the hybrid radiant trays as these are designed to absorb heat and at maximum temperatures glow red hot!

IMPORTANT!

Stainless steel tends to rust in presence of chlorides and sulfides especially in coastal area. To improve rust prevention, wash all stainless steel surfaces every 3-4 weeks with fresh water and stainless steel cleaner. Capital will not warrantee for rust due to failure to follow recommendations set forth in this section.

The grill is constructed out of non-rusting and non-magnetic stainless steel. After initial usage, areas of the grill may discolor from the intense heat given off by the burners: this condition is normal. To touch up noticeable scratches in the stainless steel, sand very lightly with dry 100 grit emery paper in the direction of the grain. Specks of grease can gather on the surfaces of the steel and bake on the surface giving a "rust-like" appearance. For removal, use an abrasive pad in conjunction with a stainless steel cleaner. Always rub in the direction of the grain.

BURNER REMOVAL AND CLEANING

GRILL BURNER:

WARNING! To prevent burns, make sure the burner is cool before removing for cleaning.

Remove the grill grates. Then lift out the radiant trays. Grasp the burner and pull it up carefully and slightly towards the rear wall of the unit so the burner head comes off the brass orifice at the front. Angle the burner sideways and remove.

(Fig 14 AND FIG 15)



FIG 14

GRILL BURNER CLEANING:

Clean the burner exterior with a wire brush. Clear stubborn scale with a metal scraper. Clear any clogged ports with a straightened paper clip. Never use a wooden toothpick as it may break off and clog the port. Shake out any debris through the air shutter. Use a flashlight to inspect the burner inlet to ensure it is not blocked. If obstructions is seen, use a straightened metal wire coat hanger to remove debris.



FIG 15

ORIFICE CLEANING:

With the burner removed, remove the orifice and shine a flashlight through the opening to ensure there is no blockage. Use a needle to clear any debris. Be extremely careful not to enlarge the hole or break off the needle.

WARNING! It is extremely important to engage the burner on the orifice properly to prevent a fire hazard or explosion.

Be careful not to upset the air shutter's original position (unless readjusting). Lower the rear of the burner into the cut outs on the support channel at the rear of the burner box. Make sure it is level and does not rock. Light all the burners and check for proper flame characteristics. If adjustments are necessary, refer to section on Flame Adjustment in this guide. Do this prior to cooking on the grill.

TROUBLE SHOOTING

Before Calling For Service:

If the grill does not function properly, use the following checklist before contacting your dealer for service. You may save the cost of a service call. Troubleshooting is for general purposes only. If the problem persists and requires a service call, contact your dealer or the nearest authorized service agency to perform service. Only authorized service agencies can perform warranty service. Call Capital Precision Series Specialist at 1.866.402.4600

Grill won't light when knob is turned:

- ❖ Remove the grill top grates and the radiant trays, watch the ignition tip. You should see the igniter rod glow brightly.
- ❖ If there is no glow when the knob is in an ON position, check the electrical connections and breakers.

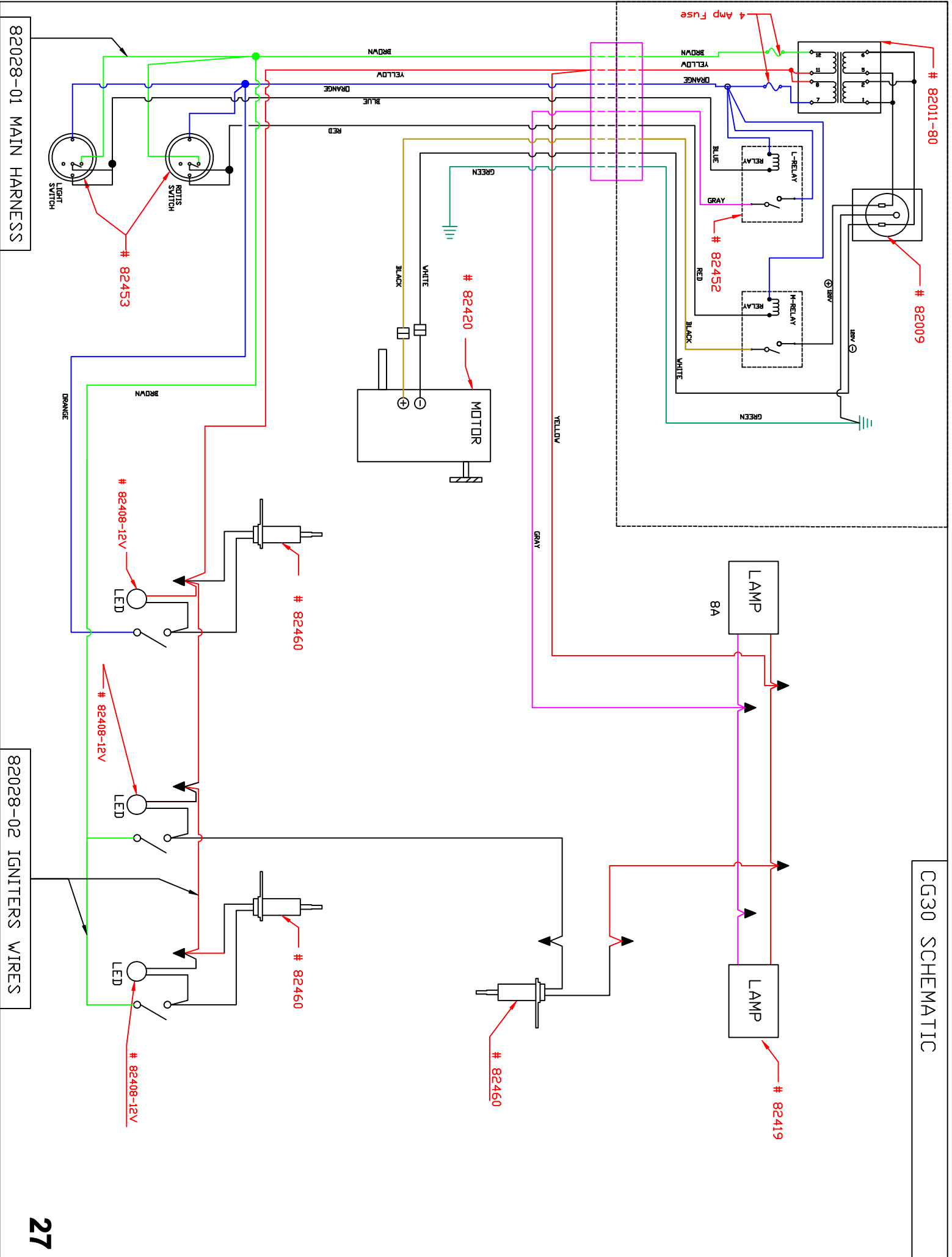

82028-01 MAIN HARNESS

82028-02 IGNITERS WIRES

CG40 SCHEMATIC

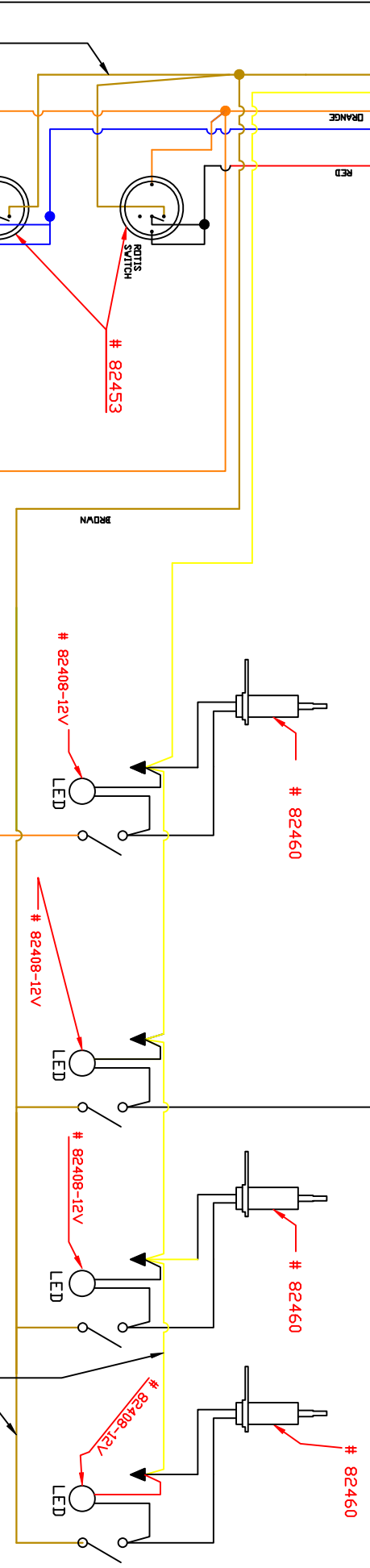
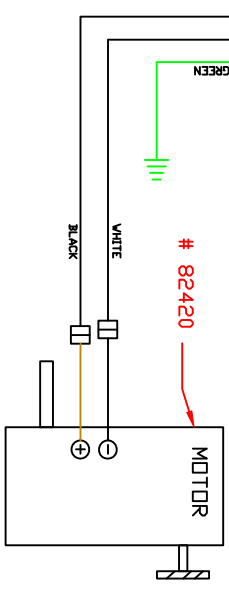
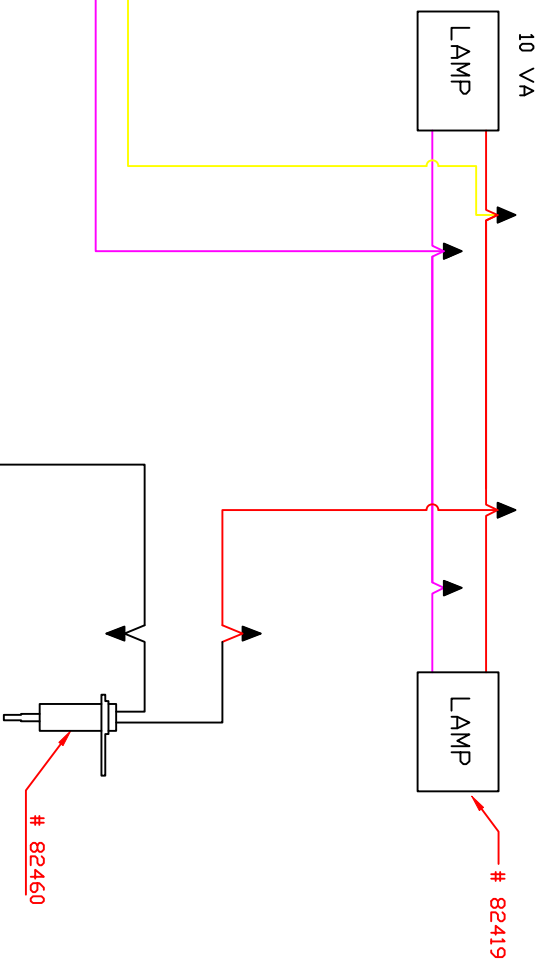
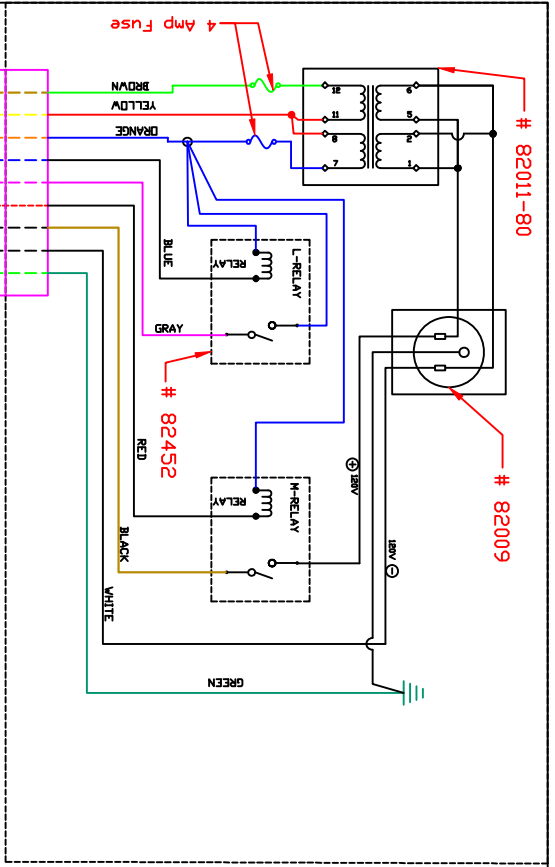

82028-01 MAIN HARNESS

82028-02 IGNITERS WIRES

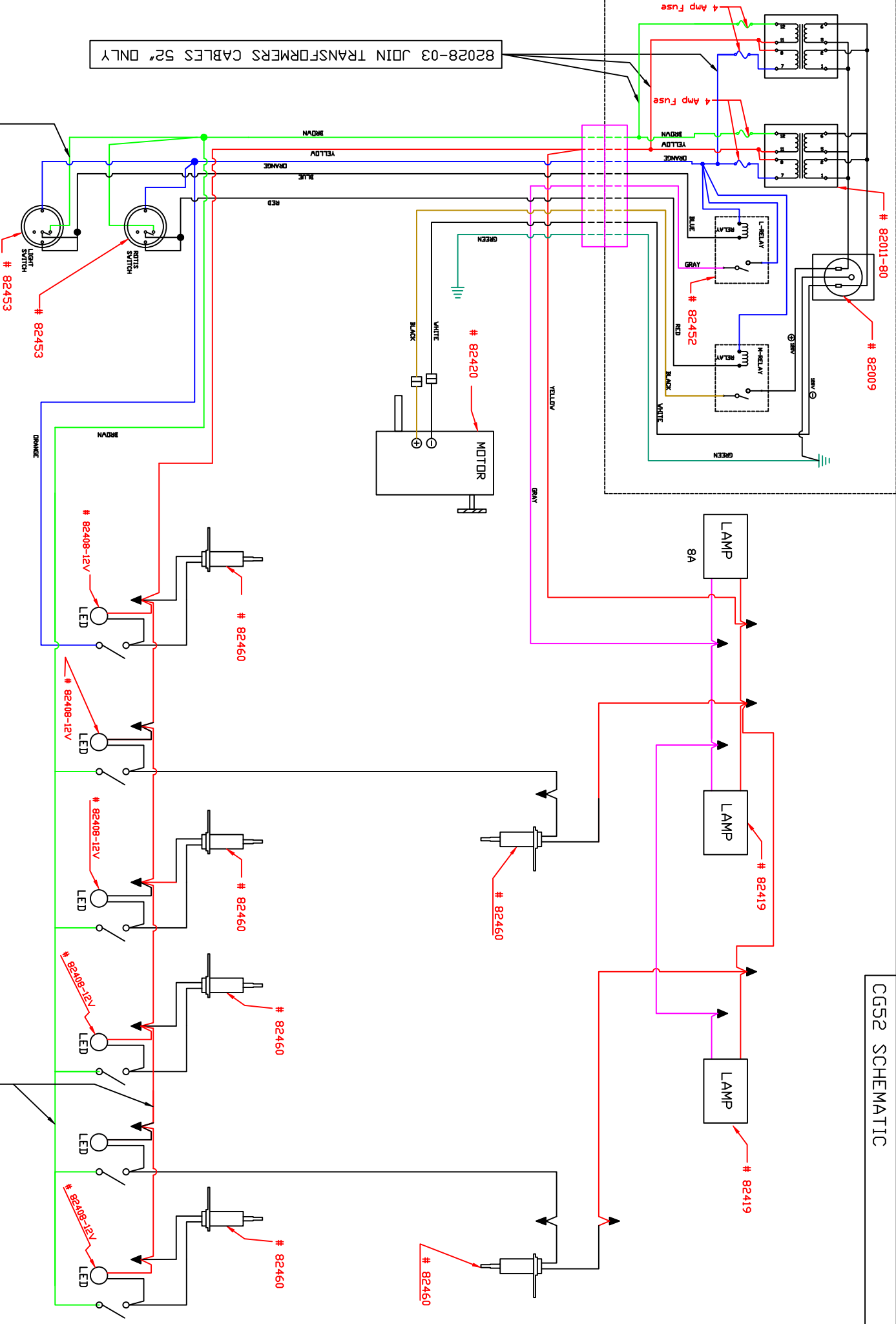

82028-03 JOIN TRANSFORMERS CABLES 52" ONLY

82028-01 MAIN HARNESS

82028-02 IGNITERS WIRES

A. 82419 Light Bulb
 B. 82419-02 Light Cover

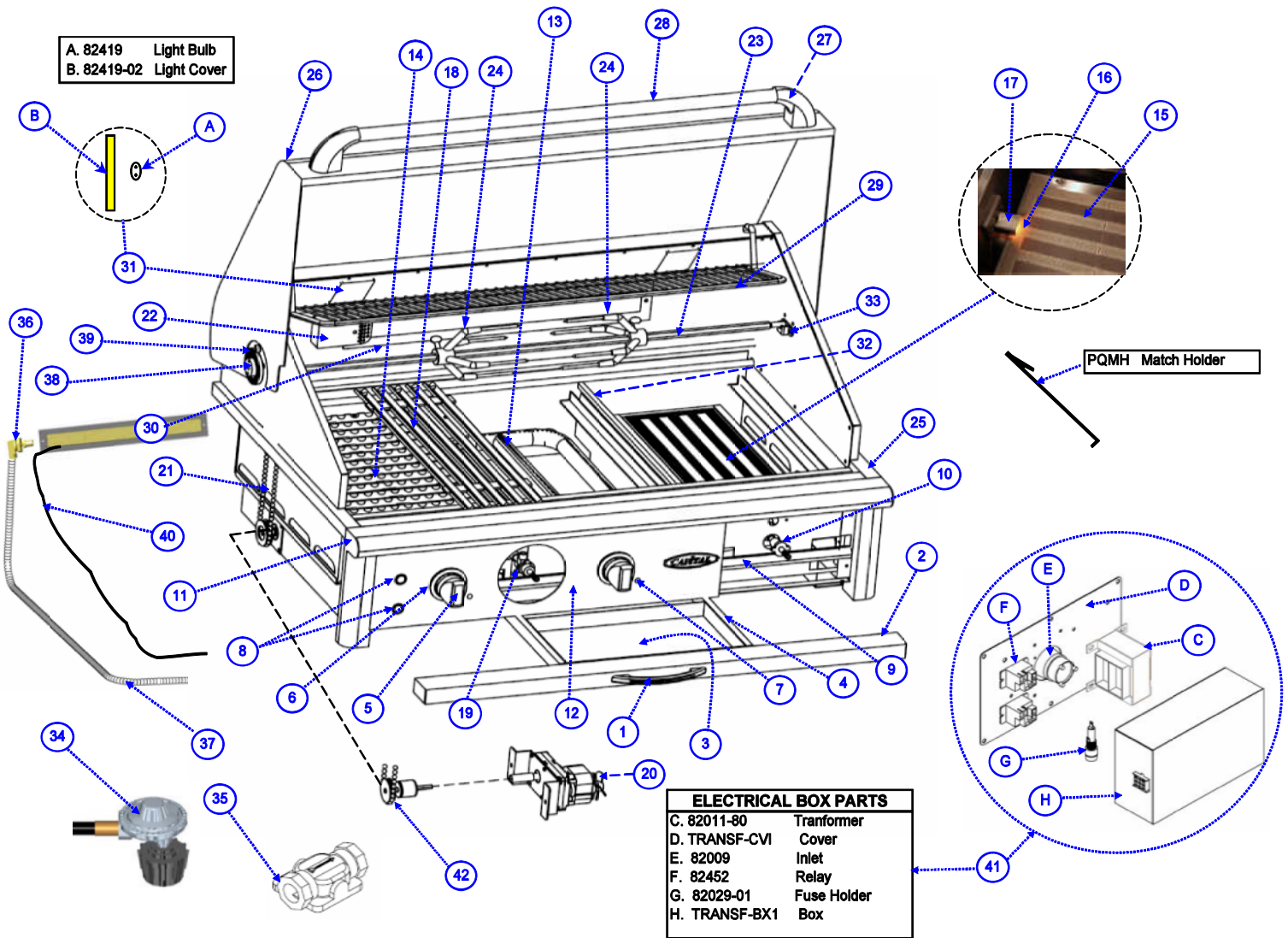

ELECTRICAL BOX PARTS

C. 82011-80	Transformer
D. TRANSF-CVI	Cover
E. 82009	Inlet
F. 82452	Relay
G. 82029-01	Fuse Holder
H. TRANSF-BX1	Box

GRILL SIZE 30"	
PART NUMBER	DESCRIPTION
1. 81013	Drawer Handle
2. P10533-30-PA	Drip Pan Handle
3. 10743-04	Drip Pan Tray
4. 81011-02	Slide Tray
5. 83014-04	Knob
6. 81304-02	Bezel
7. 82408-12V	Indicator Light
8. 82453	Rotisserie and Light Switch
9. 86003-30	Manifold For 40" BBQ
10. 82350	Gas Valve
11. P-10505-30	Landing Ladge
12. PQ-VPP-30	Valve Panel
13. 82321-02	Precision Burner
14. 10750-01	Ceramic Radiant
15. 82322-01	Grill Infra-Red Burner
16. 82460	Glow Igniter
17. 10768-03	Gas Collector
18. 80012-01	Grill Rack 11.475"
18. 80012-02	Grill Rack 4.075"
19. 82360	Safety Valve
20. 82420	Rotisserie Motor
21. 81209-01	Chain
22. 10508	Electrode Cover
23. P-10561-30	Rotisserie Rod 40"
24. 80006-03	Meat Holder Cast S/S
25. P-10509-30	Fire Box 40"
26. P-10507-30	Top Lid 40"
27. 81000-02	Tube End Cap
28. 10018-30	Handle Tube
29. 80011-30	Warming Rack
30. 82320-02	Rotisserie Infra-Red Burner
31. 82419	Grill Light
32. 10563-01	BBQ Heat Divider
33. 20595-BQ	Rod Support Bracket
34. 82205	LP Gas Regulator
35. 82148	NT Gas Regulator
36. 855555	Elbow
37. 86010-01	S/S flex Tube
38. 84100-01	Spring Holder & Spacer
39. 81208	Spring
40. 82414-01	Thermocouple
41. CGM40TB	Electrical Box for 30" & 40"
42. 81209-02	Rotisserie Mechanism

GRILL SIZE 40"	
PART NUMBER	DESCRIPTION
1. 81013	Drawer Handle
2. P10533-40-PA	Drip Pan Handle
3. 10743-04	Drip Pan Tray
4. 81011-02	Slide Tray
5. 83014-04	Knob
6. 81304-02	Bezel
7. 82408-12V	Indicator Light
8. 82453	Rotisserie and Light Switch
9. 86003-40	Manifold For 40" BBQ
10. 82350	Gas Valve
11. P-10505-40	Landing Ladge
12. PQ-VPP-40	Valve Panel
13. 82321-02	Precision Burner
14. 10750-01	Ceramic Radiant
15. 82322-01	Grill Infra-Red Burner
16. 82460	Glow Igniter
17. 10768-03	Gas Collector
18. 82323-01	Channel Grates Only 40" & 52"
19. 82360	Safety Valve
20. 82420	Rotisserie Motor
21. 81209-01	Chain
22. 10508	Electrode Cover
23. P-10561-40	Rotisserie Rod 40"
24. 80006-03	Meat Holder Cast S/S
25. P-10509-40	Fire Box 40"
26. P-10507-40	Top Lid 40"
27. 81000-02	Tube End Cap
28. 10018-40	Handle Tube
29. 80011-40	Warming Rack
30. 82320-01	Rotisserie Infra-Red Burner
31. 82419	Grill Light
32. 10563-01	BBQ Heat Divider
33. 20595-BQ	Rod Support Bracket
34. 82205	LP Gas Regulator
35. 82148	NT Gas Regulator
36. 855555	Elbow
37. 86010-01	S/S flex Tube
38. 84100-01	Spring Holder & Spacer
39. 81208	Spring
40. 82414-01	Thermocouple
41. CGM40TB	Electrical Box for 30" & 40"
42. 81209-02	Rotisserie Mechanism

GRILL SIZE 52"	
PART NUMBER	DESCRIPTION
1. 81013	Drawer Handle
2. P10533-52-PA	Drip Pan Handle
3. 10743-04	Drip Pan Tray
4. 81011-02	Slide Tray
5. 83014-04	Knob
6. 81304-02	Bezel
7. 82408-12V	Indicator Light
8. 82453	Rotisserie and Light Switch
9. 86003-52	Manifold For 40" BBQ
10. 82350	Gas Valve
11. P-10505-52	Landing Ladge
12. PQ-VPP-52	Valve Panel
13. 82321-02	Precision Burner
14. 10750-01	Ceramic Radiant
15. 82322-01	Grill Infra-Red Burner
16. 82460	Glow Igniter
17. 10768-03	Gas Collector
18. 82323-01	Channel Grates Only 40" & 52"
19. 82360	Safety Valve
20. 82420	Rotisserie Motor
21. 81209-01	Chain
22. 10508	Electrode Cover
23. P-10561-52	Rotisserie Rod 40"
24. 80006-03	Meat Holder Cast S/S
25. P-10509-52	Fire Box 40"
26. P-10507-52	Top Lid 40"
27. 81000-02	Tube End Cap
28. 10018-40	Handle Tube
29. 80011-52	Warming Rack
30. 82320-02	Rotisserie Infra-Red Burner
31. 82419	Grill Light
32. 10563-01	BBQ Heat Divider
33. 20595-BQ	Rod Support Bracket
34. 82205	LP Gas Regulator
35. 82148	NT Gas Regulator
36. 855555	Elbow
37. 86010-01	S/S flex Tube
38. 84100-01	Spring Holder & Spacer
39. 81208	Spring
40. 82414-01	Thermocouple
41. CGM52TB	Electrical Box for 52"
42. 81209-02	Rotisserie Mechanism

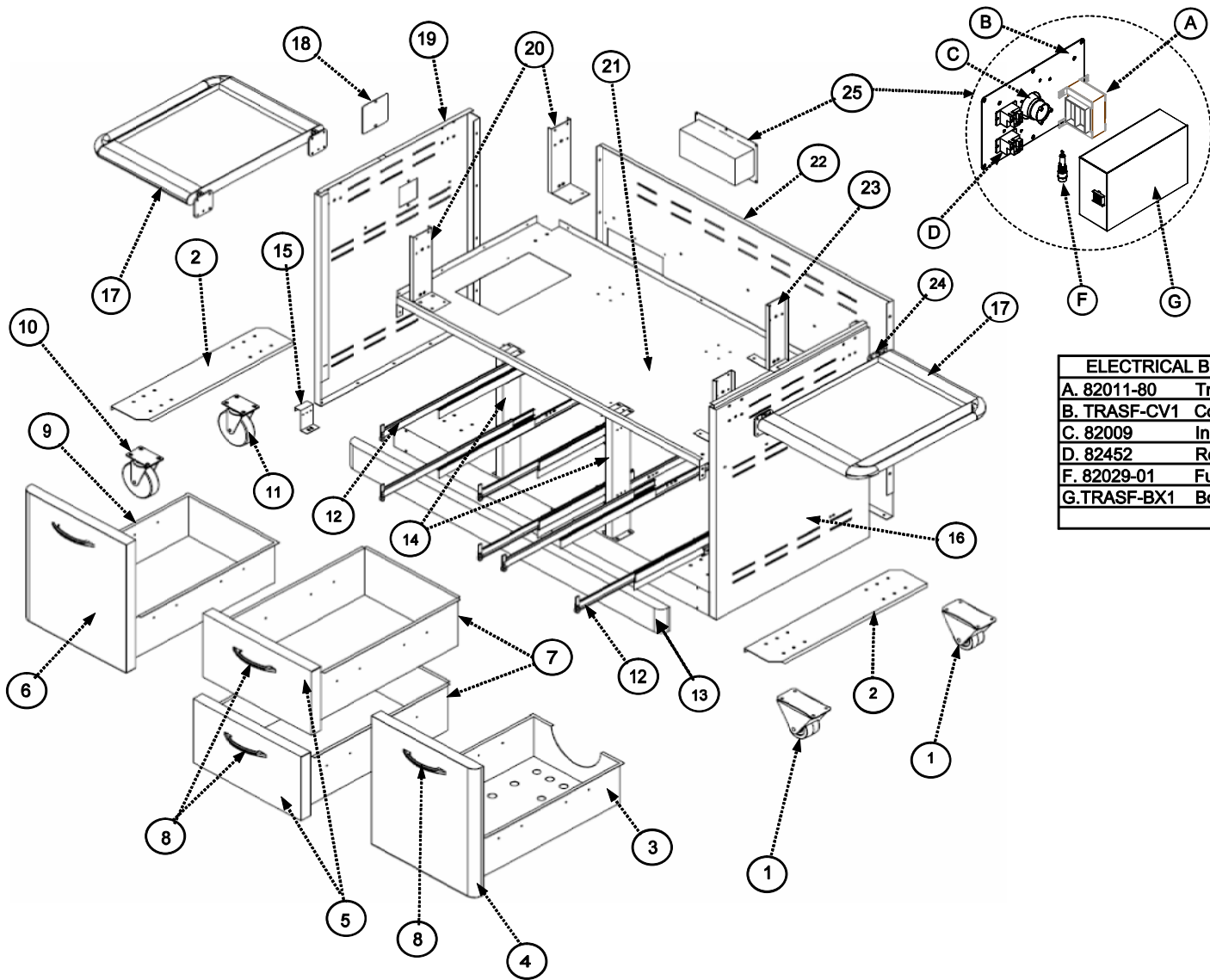

ELECTRICAL BOX PARTS	
A. 82011-80	Transformer
B. TRASF-CV1	Cover
C. 82009	Inlet
D. 82452	Relay
F. 82029-01	Fuse Holder
G. TRASF-BX1	Box

MODEL SIZE 52"	
PART NUMBER	DESCRIPTION
1. 81203	Caster 5" Rigid
2. 10577	Caster
3.P10573-40	Drawer For Horizontal Tank
4. 10576-40	40" & 52" Right Drawer Door
5. 10571-52	Door Middle Drwawer
6. 10575-52	Left Door For 52"
7. 10574-52	Drawer Middle Box For 52"
8. 81013	8. Drawer Handle
9. 10572-52	Drawer Trash Box For 52"
10. 81204	Caster 5" Swivel W/Brackt
11. 81204-01	Caster 5" Swivel W/Out Brackt
12. 81011	Slide Drawer
13. 10598-52	Kick Plate 52"
14. 10745	Drawer Slide Support
15. 10582	Back Slide Supprt
16. 10741-RH	Right Side
17. 10590-07	Side Shelf Assy
18. 10741-CC	Pulley Cover
19. P10741-LH	Left Side
20. 10747	Shelf Reinforce W/A
21. P10742-52	Top Panel 52"
22. 10740-52	Back Cart 52"
23. 10747-01	Shelf Reinforce W/A
24. 10590-03	Shelf Support
25. CGM52TB	Electrical Box for 52

MODEL SIZE 40"	
PART NUMBER	DESCRIPTION
1. 81203	Caster 5" Rigid
2. 10577	Caster
3.P10573-40	Drawer For Horizontal Tank
4. 10576-40	40" & 52" Right Drawer Door
5. 10571-40	Door Middle Drwawer
6	
7. 10574-40	Drawer Middle Box For 40"
8. 81013	8. Drawer Handle
9	
10. 81204	Caster 5" Swivel W/Brackt
11. 81204-01	Caster 5" Swivel W/Out Brackt
12. 81011	Slide Drawer
13. 10598-40	Kick Plate 40"
14. 10745	Drawer Slide Support
15. 10582	Back Slide Supprt
16. 10741-RH	Right Side
17. 10590-07	Side Shelf Assy
18. 10741-CC	Pulley Cover
19. P10741-LH	Left Side
20. 10747	Shelf Reinforce W/A
21. P10742-40	Top Panel 40"
22. 10740-40	Back Cart 40"
23. 10747-01	Shelf Reinforce W/A
24. 10590-03	Shelf Support
25. CGM40TB	Electrical Box for 30" & 40"

MODEL SIZE 30"	
PART NUMBER	DESCRIPTION
1. 81203	Caster 5" Rigid
2. 10577	Caster
3.10573-30	Drawer For Horizontal Tank
4. 10576-30	40" & 52" Right Drawer Door
5	
6. 10575-30	Left Door For 30"
7	
8. 81013	8. Drawer Handle
9. 10572-30	Drawer Trash Box For 30"
10. 81204	Caster 5" Swivel W/Brackt
11. 81204-01	Caster 5" Swivel W/Out Brackt
12. 81011	Slide Drawer
13. 10598-30	Kick Plate 30"
14. 10745-01	Drawer Slide Support
15	
16. 10741-RH	Right Side
17. 10590-07	Side Shelf Assy
18. 10741-CC	Pulley Cover
19. P10741-LH	Left Side
20. 10747-01	Shelf Reinforce W/A
21. P10742-30	Top Panel 30"
22. 10740-30	Back Cart 30"
23. 10747-01	Shelf Reinforce W/A
24. 10590-03	Shelf Support
25. CGM40TB	Electrical Box for 30" & 40"

WARRANTY

Capital Cooking Equipment, Inc. - Precision Series Grill Warranty

One (1) Year Full Warranty: Capital Cooking Equipment warrants the outdoor gas grill and all of their component parts, to be free from defects in materials and workmanship under normal residential use for a period of one (1) year from the original date of purchase. Capital Cooking Equipment will repair or replace, at its option, any part, which fails or is found to be defective during the warranty period, at no cost to the original purchaser. Warranty service must be performed by a Capital Cooking Equipment authorized representative during normal business hours.

Five (5) Year Limited Warranty: Capital Cooking Equipment warrants the gas valves, sear zone burners, rotisserie burners, drip pans and the stainless steel encasements for the ceramic rods to be free from defects in materials and workmanship, under normal residential use, for a period of five (5) years from the original date of purchase. This warranty excludes surface corrosion and heat discoloration which may occur from normal use. Capital Cooking Equipment will repair or replace, at its option, the actual part found to be defective, with the owner paying for all other costs including labor and freight.

Limited Lifetime Warranty: Capital Cooking Equipment warrants the stainless steel main burners, stainless steel cooking grates and the stainless steel body housings to be free from defects in material and workmanship under normal residential use and service for the lifetime of the original purchaser. This warranty excludes surface corrosion, scratches and discoloration which may occur during regular use. This warranty is limited to the replacement of the defective parts, with the owner paying all other costs including labor and freight.

Warranty Limitations and Exclusions:

- Warranty applies only to the original purchaser and may not be transferred.
- Warranty coverage begins on the original date of purchase and proof of date of purchase is required. In order to activate the warranty, customer must send in warranty registration card.
- Warranty applies only to the products purchased and located in the continental United States and Canada.
- This warranty does not apply to damages resulting from negligence, alteration or tampering with the appliance, misuse, abuse, accident, natural disaster, hostile environment, flare-up fires, improper installation, and installation which is not in accordance with instructions in the product manual or the local codes.
- This warranty does not apply to dings, dents, scratches or damage due to the use of harsh cleaning chemicals.
- This warranty does not cover installation or start-up damages or problems caused by improper installation or use.
- This warranty does not cover service by an unauthorized service provider, or the use of unauthorized parts.
- This warranty does not apply to commercial use, or to products with altered or removed serial numbers.
- No one has the authority to add to, or vary the Capital Cooking Equipment Grill Warranty, or to create for Capital any other obligation or liability in connection with the sale or use of its products.
- Capital Cooking Equipment shall not be liable for incidental, consequential, special or contingent damages resulting from its breach of this written warranty or any implied warranty.

WE RESERVE THE RIGHT TO CHANGE THESE SPECIFICATIONS OR DESIGN WITHOUT NOTICE.



THE ART OF PRECISION™

**13211 E. FLORENCE AVE. SANTA FE SPRINGS, CA 90670.
PHONE 866-402-4600
WWW.CAPITAL-COOKING.COM**

PART NO 87093-01