

This Owner's Manual is provided and hosted by [Appliance Factory Parts](#).

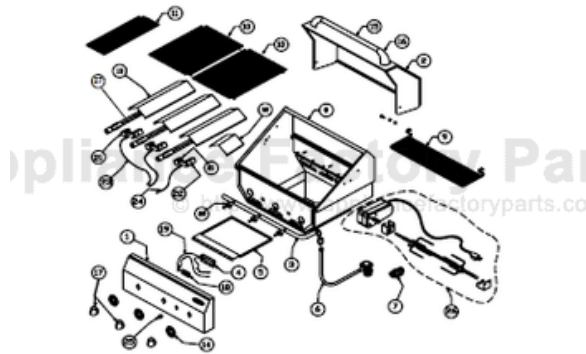

# Capital Cooking PRO-4N Owner's Manual

[Shop genuine replacement parts for Capital Cooking  
PRO-4N](#)



[Find Your Capital Cooking Grill Parts - Select From 20 Models](#)

----- Manual continues below -----



## USE AND CARE MANUAL



# PRO SERIES

## MODELS

<b>PRO-3L</b>	<b>3 BURNER "PRO SERIES" BUILT IN BBQ LP</b>
<b>PRO-3N</b>	<b>3 BURNER "PRO SERIES" BUILT IN BBQ NG</b>
<b>PRO-4L</b>	<b>4 BURNER "PRO SERIES" BUILT IN BBQ LP</b>
<b>PRO-4N</b>	<b>4 BURNER "PRO SERIES" BUILT IN BBQ NG</b>

**FOR OUTDOOR USE ONLY!**

# TABLE OF CONTENTS

	DESCRIPTION	PAGE
	TABLE OF CONTENTS	1
✱	SAFETY PRECAUTIONS	1
✱	GRILL PLACEMENT	3
✱	FEATURES	4
✱	GAS HOOK UP	5
✱	LEAK TESTING	6
✱	AIR SHUTTER ADJUSTMENTS	7
✱	INSTALLER'S FINAL CHECK LIST	8
✱	BUILT IN SPECIFICATIONS	9
✱	PARTS LIST	10
✱	LIGHTING INSTRUCTIONS	11
✱	USING THE GRILL	11
✱	ROTISSERIE KIT INSTALLATION (OPTIONAL ACCS)	12
✱	WARRANTY INFORMATION	13
✱	NOTES	14

## SAFETY PRECAUTIONS

### FOR YOUR SAFETY

If you smell gas:

- a). Shut off gas to the **GRILL**
- b). Extinguish any open flames
- c). Open **GRILL LID**
- d). If odor continues, immediately call your gas supplier

### WARNING

Do not attempt to light the grill without reading **LIGHTING INSTRUCTIONS** section of this manual on page 11

### FOR YOUR SAFETY

Do not store or use gasoline or other flammable vapors and liquids in the vicinity of this or any other appliance

TESTED IN ACCORDANCE WITH ANSI 221.58b-2000  
CGA 1.6b-M02 For LP and Natural Gas  
STANDARD FOR OUTDOOR USE ONLY.

Check your local building codes for the proper method of installation.  
In the absence of local codes, this unit should be installed in accordance with the National Fuel Gas Code No. Z223.1-1988 and the National Electrical Code ANSI/NFPA No. 70-1990.

# SAFETY PRECAUTIONS

## CALIFORNIA PROPOSITION 65 - WARNING

The burning of gas cooking fuel generates some by products which are on the list of substances which are known by the State of California to cause cancer or reproductive harm. California Law requires Businesses to warn customers of potential exposure to such substances.

To minimize exposure to these substances, always operate this unit according to the USE AND CARE MANUAL, ensuring you provide good ventilation when cooking with gas.

**CHILDREN & PETS SHOULD NOT BE LEFT ALONE OR UNATTENDED  
IN AN AREA WHERE THE GRILL IS BEING USED!**

## **SAFETY PRACTICES TO AVOID PERSONAL INJURY**

When properly cared for, your Grill will give safe reliable service for many years. However, extreme care must be used since the grill produces intense heat and can increase accident potential. When using your grill, basic safety practices must be followed, including but not restricted to the following.

Read this CARE and USE MANUAL carefully and completely before using your grill to reduce the risk of fire hazard or other injury.

Do not repair or replace any part of your Grill unless specifically recommended in this manual. All other service should be referred to a qualified technician. Do not store items of interest to children around or below the Grill. Never allow children or pets to crawl inside of the island. Never let clothing, pot holders or other flammable materials come into contact with or close to any hot surface of the grill until it has cooled. Fabric may ignite and result in personal injury.

For personal safety, **NEVER lean over the Grill while in use.** Wear proper apparel. loose fitting garments or sleeves should never be worn while using this Grill. Some synthetic fabrics are highly flammable and should not be worn while cooking.

Only certain types of glass, heat-proof glass, ceramic earthenware, or other glazed utensils are suitable for Grill use. Use of these types of materials may break with sudden temperature changes. Use only on low or medium heat settings according to the manufacturer's instructions.

Do not heat unopened food containers as a build-up of pressure may cause the container to burst. Protect hands with oven mitts when opening and closing the Grill lid.

***When lighting a burner, always pay close attention to lighting instructions on page 11.***

When using the Grill, NEVER touch the Grill rack, flame spreader or immediate surrounding area as these areas become extremely hot and could cause burns.

Use only dry potholders: moist or damp potholders on hot surfaces may cause burns from steam. do not use a towel or bulky cloth in place of potholders. Do not let potholders touch hot portions of the Grill rack.

Grease is flammable. Let hot grease cool before attempting to handle it. Avoid letting grease deposits collect at the bottom of the grill. **Clean often.**

## **SAFETY PRECAUTIONS**

For proper lighting and performance of the burners keep the burner ports clean. It is necessary to clean them periodically for optimum performance. The burners will only operate in one position and must be mounted correctly for safe operation.

Clean the Grill with caution. Avoid steam burns; do not use a wet sponge or cloth to clean the Grill while it is hot. Some cleaners produce noxious fumes or can ignite if applied to a hot surface.

Be sure all Grill controls are turned off and the Grill is cool before using any type of aerosol cleaner on or around the grill. The chemical that produces the spraying action could, in the presence of heat, ignite or cause metal parts to corrode.

**Do not use the Grill for cooking excessively fatty meats or products which promote flare-ups.**

Do not operate the Grill under unprotected combustible construction. Use only in well ventilated areas. Do not use on boats, recreation vehicles, or in buildings, garages, sheds etc.

**NOTE: THIS GRILL IS FOR OUTDOOR USE ONLY**

Keep all electrical supply cords and fuel supply hoses away from the heated areas of the Grill.

**Never** use the Grill in windy conditions. If located in a consistently windy area (oceanfront, mountaintop etc.) a wind breaker will be required.

Always adhere to the specified clearances. **Combustible locations, rear 18" , sides 20"**

**NEVER USE A DENTED OR RUSTY L.P. OR BUTANE TANK.**

The pressure regulator and hose assembly supplied by this unit must be used. Contact manufacturer on back of this Manual for replacement parts.

## **GRILL PLACEMENT**

### **CLEARANCE TO NON-COMBUSTIBLE CONSTRUCTION**

A minimum of 3" clearance from the back of the Grill to non-combustible construction is required for the lid to open fully

**DO NOT INSTALL THE GRILL IN  
COMBUSTIBLE ENCLOSURES!!**

### **LOCATION**

When determining a suitable location take into account concerns such as exposure to wind, proximity to traffic paths and keeping gas supply lines as short as possible.

Locate the Grill only in a well ventilated area. Never locate the Grill in a building, garage, breezeway, shed or other such enclosed areas without an approved ventilation system.

During heavy use the Grill will produce considerable smoke.

## FEATURES

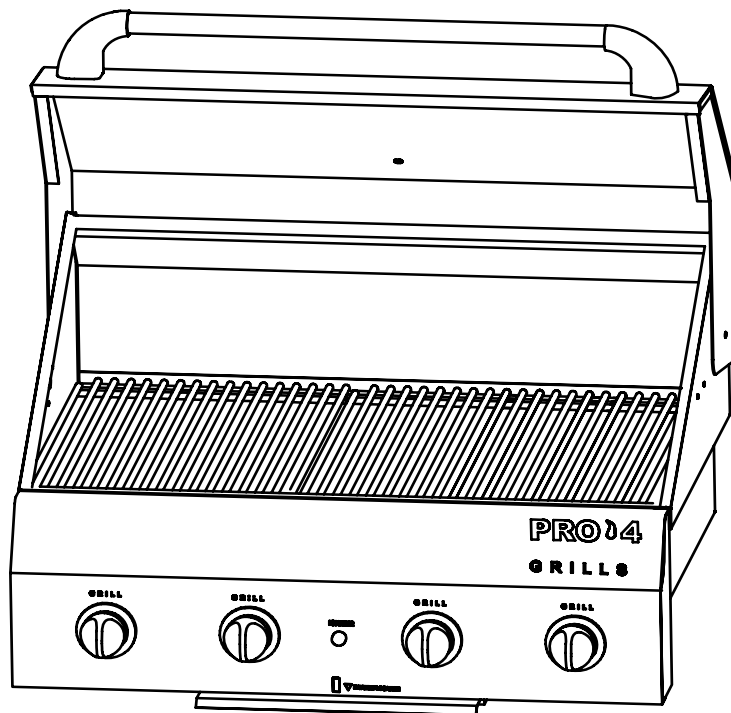

- Commercial grade stainless steel
- 4 Stainless steel tube burners  
burners at 12,500 BTU's each
- Electronic ignition (batteries required)
- Stainless steel grill grates
- Warming rack
- stainless steel radiant system
- Double lined hood
- Thermometer
- Chrome plated knobs
- Chrome plated end caps
- Chrome plated bezels
- Optional Rotisserie System
- Width: 26 AND 30 inches
- Our 3 burner grill Fits standard 3 burner turbo  
cut-outs by Barbeques Galore

# **GAS HOOK UP**

**IF OPERATING THIS UNIT OUTSIDE THE USA,  
PLEASE CONSULT YOUR LOCAL CODES!**

Never connect an unregulated gas line to the Grill  
Total gas consumption (BTU per hour) of the Grill with all burners on "HI"

( 37,500 BTU/HR PRO-3) AND ( 50,000K BTU/HR PRO -4 )  
PRO-3L ORIFICES SIZE= 59    POR-3N ORIFICES SIZE= 51  
PRO-4L ORIFICES SIZE= 59    POR-4N ORIFICES SIZE= 51

The installation of this Grill must conform with local codes or, in the absence of local codes, with the national fuel gas code

## **L. P. TANK REQUIREMENTS**

A dented or rusty L. P. tank may be hazardous and should be checked by your gas supplier  
Never use a cylinder with a damaged valve.

### **FOR BUTANE GAS TANKS CHECK THE LOCAL SPECIFICATIONS**

The L. P. gas cylinder must be constructed and marked in accordance with the specifications for L. P. Gas cylinders of the U. S. Department of Transportation (DOT). The cylinder must be provided with a shut off valve terminating in an L. P. Gas supply cylinder valve outlet specified, as applicable, for connection type Qcc1 in the standard for compressed gas cylinder valve outlet and inlet connection ANSI/CGA-V-1.                      Manifold pressure: (operating): 10" W.C.

## **CONNECTION**

All Grills using L. P. gas come equipped with a high capacity hose/regulator assembly for connection to a standard 20 lb. L. P. cylinder (18 1/4" high, 12 1/4" diameter).

## **THE L. P. TANK IS NOT INCLUDED**

Hose and regulator assembly is shipped ready for connection to L.P. Tank.

### **NATURAL GAS CONNECTION**

Natural Gas: Manifold connection: 1/2 NPT male with 1/2 coupling

**OPERATING PRESSURE:** 4.0 W.C. Supply pressure 5" to 14" water column.

If in excess of 14" W.C. a step down regulator is required. Check with your local gas utility or with local codes for instructions or installing gas supply lines.**TO HOOK UP THE FITTINGS SUPPLIED WITH THE GRILL** Use threading compound on male threads only.

Do not use threading compound on the male end of the 1/2 NPT to 3/8-flare adapter. Use a second pipe wrench to hold the grill inlet pipe to avoid shifting any internal gas lines of the grill. Ensure that the regulator arrow points in the direction of gas flow towards the unit, away from the supply. Do not forget to place the installer supplied gas shut-off valve in an accesible location.

### **PARTS SUPPLIED WITH THE UNIT:**

(1) NAT GAS REGULATOR, (2) 1/2 NPT NIPPLE,

# LEAK TEST

## TO TEST

Make sure all control valves are in the "OFF" position. Turn the gas supply on. Check all connections from the supply line, or L.P. cylinder up to and including the manifold pipe assembly.

Make a soap solution of one part liquid detergent and one part water. Apply the solution around the connection, valve, and tubing. Soap bubbles will appear where a leak is present. If a leak is detected, immediately turn off the gas supply, and tighten any leaking fittings, turn gas on, and recheck. If a gas leak is present, and you can not stop the leak, immediately turn off the gas supply and call your local gas supplier or the dealer where you purchased your Grill.

Only authorized factory parts, or parts recommended by the manufacturer should be used on the Grill.

## **Substitution WILL VOID THE WARRANTY**

**DO NOT USE THE GRILL UNTIL ALL CONNECTIONS HAVE BEEN CHECKED AND DO NOT LEAK**

**ALWAYS CHECK FOR LEAKS AFTER EVERY L. P. TANK CHANGE.**

Check all gas supply fittings for leaks before each use. It is handy to keep a spray bottle of soapy water near the shut-off valve of the gas supply line. Spray all the fittings. Bubbles will indicate where leaks are located.

The disconnected L. P. cylinders must have threaded valve plugs tightly installed, and must not be stored in a building, garage or any other enclosed area. The gas must be turned off at the supply cylinder when the unit is not in use.

If the Grill is stored indoors the cylinder must be disconnected and removed from the Grill. Cylinders must be stored outdoors in a well ventilated area out of the reach of children.

## **GENERAL**

Although all gas connections on the Grill are leak tested at the factory prior to shipment, a complete gas tightness check must be performed at the installation Site. due to possible mishandling in shipment, or excessive pressure unknowingly applied to the unit.

Periodically check the whole system for leaks, or immediately check if the smell of gas is detected.

### **BEFORE TESTING:**

**Make sure all packaging has been removed.**

**Do not smoke while testing**

**Never leak test with an open flame**

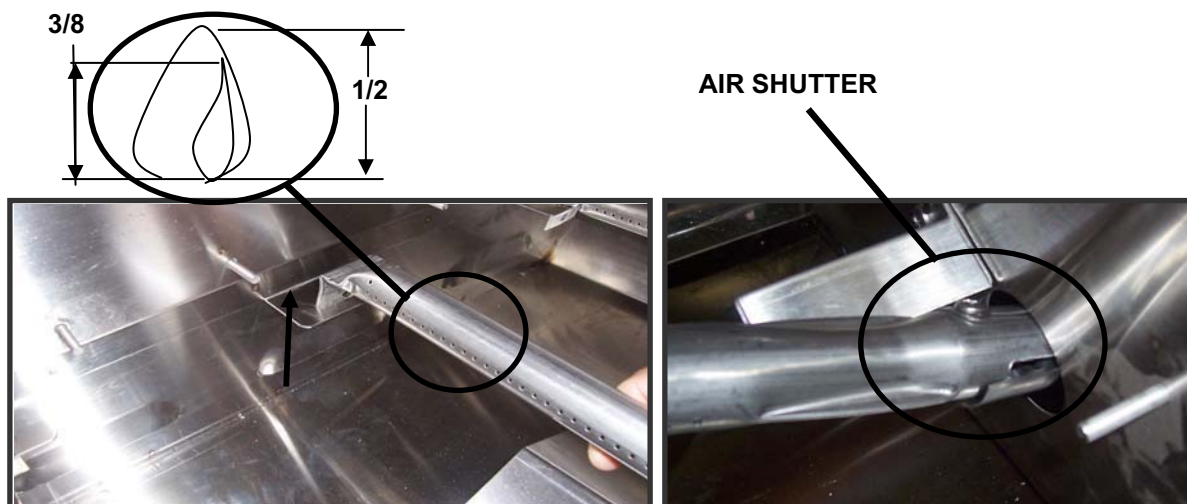

**FIGURE 1**

**Leak check the regulator to tank connections with a soap and water solution before operating**

## AIR SHUTTER ADJUSTMENTS

be visually checked and compared with the next figure.



Flames should be blue and stable with no yellow tips, excessive noise or lifting. If any of these conditions exist, check if the air shutter or burner ports are blocked by dirt, debris, spider webs, etc. and proceed with air shutter adjustment. The amount of air which is pulled through a burner is governed by a sheetmetal cup called the air shutter located at the inlet of the burner. It is locked in place by a set screw which must be loosened prior to lighting the burner for adjustment. The air shutter adjustment screws are accessible with a screwdriver. Remove the burner by pulling up as shown in previous figure. Loosen the lock screw of the air shutter. Make certain that the burners are sitting properly on the orifices and light the burners. To adjust grill burner flame, be advised to adjust according to the following directions, also be careful as the burner may be very hot. If the flame is yellow indicating insufficient air, turn the air shutter counter-clockwise to allow more air to the burner. If the flame is noisy and tends to lift away from the burner, indicating too much air, turn the air shutter clockwise, until stable blue flame is obtained.

# INSTALLERS'S FINAL CHECK LIST

## CHECK WHEN COMPLETE

- Specified clearances maintained to combustibles
- All internal packaging has been removed
- All PVC protective coating has been removed
- Knobs turn freely
- Burners are sitting properly
- Each burner lights satisfactorily, individually or with adjacent burner
- Air shutter adjusted and locked in position
- Pressure regulator connected and set for 10" W.C. L. P. gas
- Unit tested and free of leaks
- User informed of gas supply shut off valve location

## INSTALLING THE BATTERY

The battery is located behind the valve panel. It is attached by a magnetic strip. Reach behind the panel and remove the battery unplug old battery and replace with new one. Reinstall battery behind control panel.

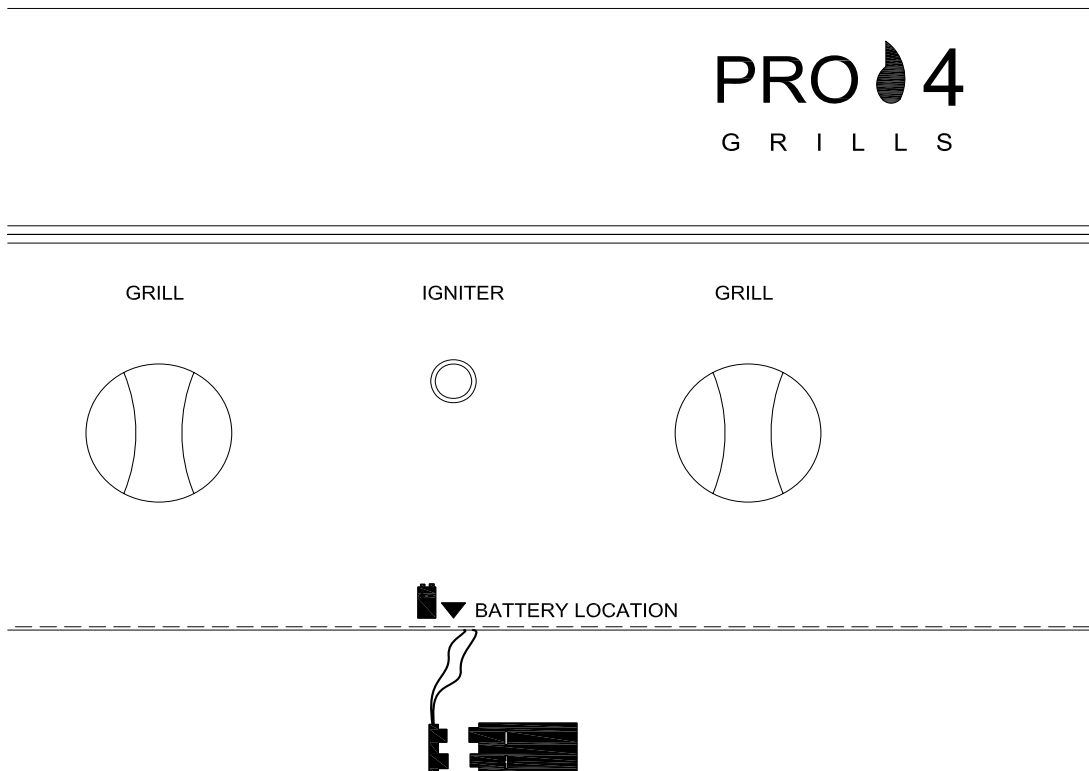

## BUILT-IN SPECIFICATIONS

### BUILT-IN SPECIFICATIONS FOR PRO-3 AND PRO-4 SERIES BBQ's

#### CAUTION: USE ONLY IN NON-COMBUSTIBLE ENCLOSURES

The appliance and its individual shut off valve must be disconnected from the gas supply piping system during any pressure testing of that system at test pressures in excess of 1/2"

PSIG(3.5 kPa.) .

The appliance must be isolated from the gas supply piping system by closing its individual manual shut-off valve during any pressure testing of the gas supply piping system at test pressures equal to or less than 1/2" PSIG(3.5 kPa.). The installation of this appliance must conform with local codes or, in the absence of local codes, to the national fuel gas code, ANSI Z223.1a-1998.

Installation in Canada must be in accordance with the Standard Can1-b149.1 and/or.2 (installation code for gas burning appliance and equipment) and local codes.

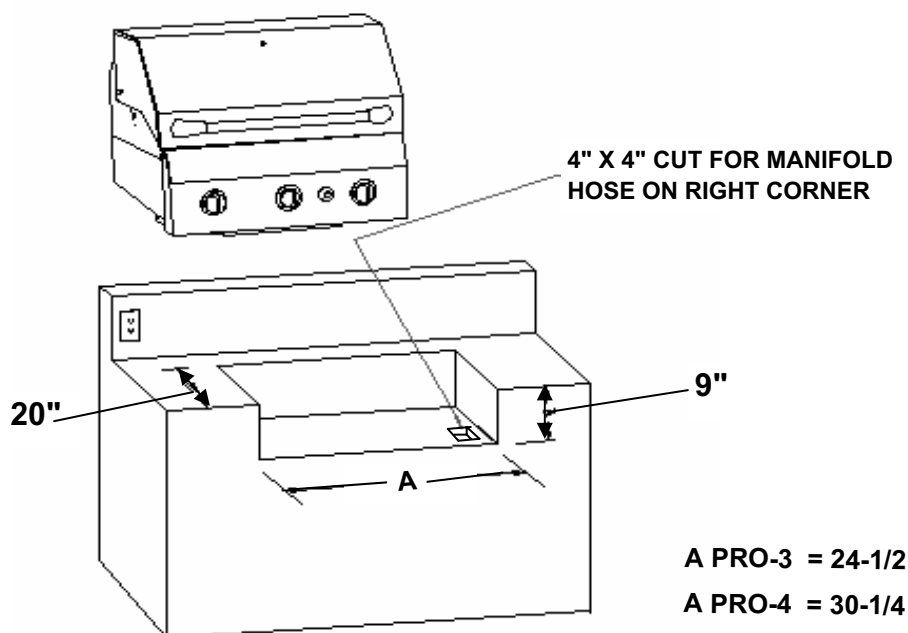

#### NOTE:

If the island has a backsplash, then the MINIMUM clearance between the bbq back and the backsplash must be 3" for lid to open freely completely.

**DO NOT INSTALL THE GRILL IN  
COMBUSTIBLE ENCLOSURES!!**

# PARTS LIST

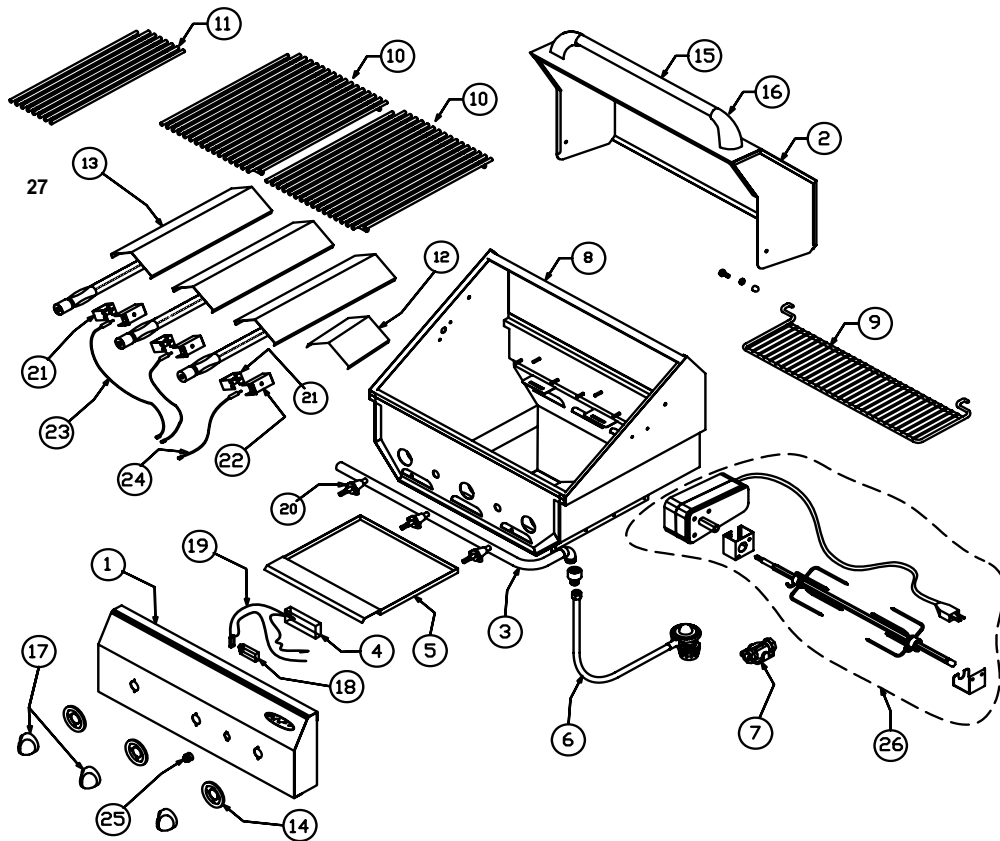

PRO-3			PRO-4		
ITEM	P/NUMBER	NAME	ITEM	P/NUMBER	NAME
1	10826-PA	FRONT PANEL W/A PRO-3	1	10826-P4-PA	FRONT PANEL W/A PRO-3
2	10822-02	TOP LID W/A PRO-3	2	10822-P4	TOP LID W/A PRO-4
3	86009	MANIFOLD FOR PRO-3	3	86003-P4	MANIFOLD FOR PRO-4
4	82417	4 IGNITER	4	82417	4 IGNITER
5	10873	DRIP TRAY	5	10873	DRIP TRAY
6	82200	LP GAS REGULATOR	6	82200	LP GAS REGULATOR
7	82203	NATURAL GAS REGULATOR	7	82203	NATURAL GAS REGULATOR
8	10852-02	FIRE BOX W/A PRO-3	8	10852-P4	FIRE BOX W/A PRO-4
9	80010	WARMING RACK	9	80010	WARMING RACK
10	80000-02	S/S GRILL RACKS	10	80000-02	S/S GRILL RACKS
11	XXXXX	XXXXXXXXXX	11	80000-04	CENTER GRILL RACK
12	10875	HEAT SHIELD	12	10875	HEAT SHIELD
13	10830	RADIANT	13	10830	RADIANT
14	81304-02	BEZEL	14	81304-02	BEZEL
15	1001 8-09	HANDLE TUBE	15	1001 8-12	HANDLE TUBE PRO-4
16	81000	HANDLE END CAP	16	81000	HANDLE END CAP
17	83002	KNOB	17	83002	KNOB
18	87040-01	BATTERY	18	87040-01	BATTERY
19	82417-02	BATTERY WIRES	19	82417-02	BATTERY WIRES
20	82100	VALVE	20	82100	VALVE
21	10842	ELECTRODE HOLDER	21	10842	ELECTRODE HOLDER
22	10841	GAS COLLECTOR	22	10841	GAS COLLECTOR
23	82000	ELECTRODE BURNER 12"	23	82000	ELECTRODE BURNER 12"
24	82012-12	ELECTRODE BURNER 36"	24	82012-12	ELECTRODE BURNER 36"
25	82418	H.E. BBQ IGNITION SWITCH	25	82418	H.E. BBQ IGNITION SWITCH
27	82327-01	TUBE BUNER	27	82327-01	TUBE BUNER

ROTISSERIE KITS SOLD SEPARATE

26	G3-RTSKT	FOR ROTISSERIE KIT PRO-3
26	PRO-4-RTSKT	FOR ROTISSERIE KIT PRO-4

## **LIGHTING INSTRUCTIONS**

Turn all knobs to " OFF " position. Turn on the gas supply. Always keep your face and body away from the grill when lighting. Open the lid, push and turn the control knob to the "HI" position and immediately press the igniter button. You will hear a clicking sound. At the same time, the electrode will spark at the burner. It may be necessary to hold down the igniter button until the burner is lit. If it does not light in 4 seconds, turn the knobs to the " OFF " position and wait 5 minutes to allow any accumulated gas to dissipate.

## **USING THE GRILL**

Each burner is rated at 12,500 BTU. The Grill burners encompass the entire cooking area and are side ported to minimize blockage from falling grease and debris. Above the burners are stainless steel radiants. All Grill burners of these series have the same electronic igniter.

### **PRIOR TO USING THE GRILL**

1. Make sure all packaging material has been removed.
2. Make sure the grill has been leak tested and is properly located.
3. Check the radiants and grill racks are properly seated.
4. Light the Grill burners using the instructions on the top of this page.
5. Turn the burner knob to "HI" and preheat the Grill for 5 minutes.
6. The Grill lid is to be kept closed during the preheat period.
7. Place the food on the Grill and cook to the desired taste.
8. Adjust heat setting if necessary. The control knob may be set to any position after "HI"

### **USING THE GRILL**

Grilling requires high heat for searing and proper browning. Most foods are cooked at the "HI" heat setting for the entire cooking time. However, when grilling large pieces of meat or poultry, it may be necessary to turn the heat to a lower setting after the initial browning. This cooks the food thoroughly without burning the outside. Foods cooked for a long time or basted with a sugary marinade may need a lower heat setting near the end of the cooking time.

**DO NOT ALLOW THE CHILDREN TO COME  
NEAR WHILE COOKING.**

# ROTISSERIE KIT INSTALLATION (OPTIONAL ACCS)

## MODELS: G3-RTSKIT PRO-RTSKIT

INSTALL THE BRACKET SUPPORT AT THE RIGHT OF THE BODY WITH THE SCREWS AND NUTS PROVIDED

TAKE THE MOTOR AND ALIGN THE 2 HOLES AND THEN INSERT 2 SCREWS AND SECURE WITH 2 WING NUTS.

TO USE THE ROTISSERIE SYSTEM IT IS NECESSARY TO REMOVE THE GRILL RACKS .

PUSH THE ROTISSERIE ROD THROUGH THE MEAT AND SECURE WITH THE FORKS

AFTER THAT TO INSERT THE END OF THE ROTISSERIE ROD IN THE ROTIS MOTOR AND THE OTHER END TO HANG ON THE BRACKET LOCATED ON THE RIGHT SIDE.

CONNECT THE ROTIS MOTOR TO AN ELECTRICAL OUTLET AND TURN ON THE MOTOR.

TURN THE BURNER KNOB TO HI AND PUSH THE IGNITER UNTIL THE BURNERS LIGHT

ONCE THE BURNERS ARE LIT CLOSE THE LID AND WAIT SEVERAL MINUTES. CHECK THE MEAT AND THEN IF NOT COOKER CLOSE THE LID AGAIN UNTIL THE MEAT IS READY .

FOR BETTER RESULTS DO NOT USE THE MIDDLE BURNER (SEE DRAWING)

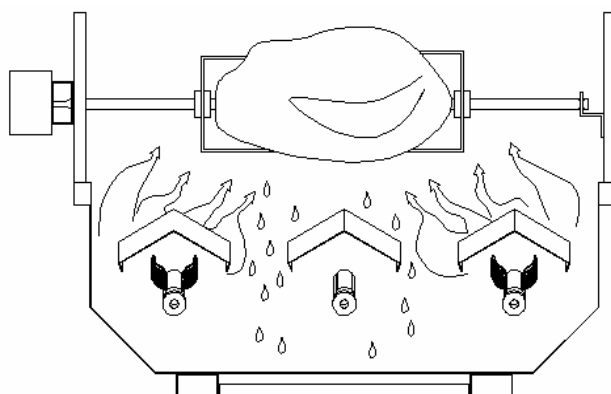

**PRO-3**

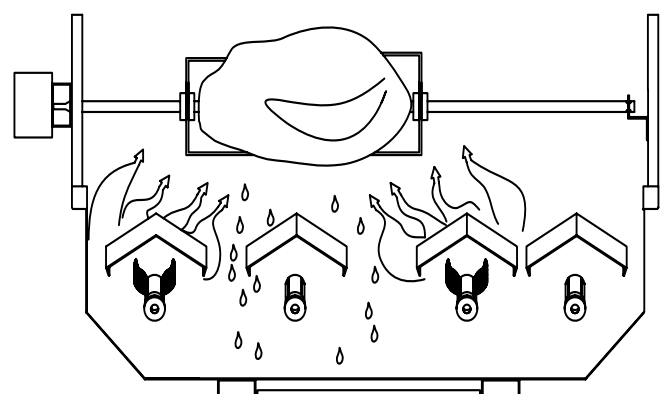

**PRO-4**

# WARRANTY

## G-SERIES

ONE (1) year full parts and labor warranty covers entire product against manufacturing defects.

TWO (2) years Limited warranty covers Radiant System and Infra-Red Burners.

FIVE (5) years Limited warranty covers all stainless steel parts and stainless steel Grill Burner provided the has been used under normal circumstances.

### **CAPITAL WILL Pay for the following:**

**All repair labor found to be defective due to materials or workmanship for one full year "IN HOME"** warranty during the first year of ownership. This does not apply if the unit was subjected to other than normal household use. Service must be performed by a factory authorized service agent during normal business hours. no charges will be made for repair or replacement at the location of initial installation or factory for parts returned pre-paid through the dealer and claimed within the warranty period, and found by Capital to be defective.

Replacement will be FOB Capital, and Capital will not be liable for any transportation costs, labor costs, or export duties. This warranty shall not apply, nor can we assume responsibility for damage that might result from a failure to follow manufacturer's instructions or local codes, where the appliance has been tampered with or altered in any way or which, in our judgment, has been subjected to misuse, negligence, or accident. Implied warranty shall not extend beyond the duration of this written warranty. This warranty is in lieu of all warranties expressed or implied and all other obligations or liability in connection with the sale of this appliance.

### **CAPITAL WILL NOT Pay For The Following:**

- Installation or start up
- Shipping damage.
- Service by an unauthorized agency.
- Damage or repairs due to service performed by an unauthorized service agency or the use of unauthorized parts.
- Service during other than normal business hours.
- Improper installation, such as improper hook-up
- Service visits to teach consumers how to use the appliance, correct the installation, and reset circuit breakers or replace home fuses.
- Repairs due to other than normal household use.
- Damage caused from accident, abuse, misuse, incorrect installation not in accordance with local codes.
- Units installed in non-residential application such as day care centers, bed and breakfast centers, churches, nursing homes, hotels, motels, schools, etc.
- Isolated geographic locations of 50 miles of travel distance or two hours of travel time both ways, for example, such places that require plane, train, boat or ferry trips, etc.

**This warranty applies to appliances used in residential application only. It does not cover** their use in commercial situations (commercial situations include but not limited to restaurants, public parks and recreation areas, any area where units are exposed to multiple users, public cooking areas etc.). This warranty is for products purchased and retained in the 50 States of the USA, the district of Columbia and Canada. This warranty applies even if you should move during the warranty period. Should the original purchaser sell the appliance during the warranty period, the new owner continues to be protected until the expiration date of the original purchaser's warranty period.

This warranty gives you the specific legal rights. You may also have other rights, which vary from State to State.





**Please Contact Us:**

**CAPITAL COOKING EQUIPMENT, INC.**

13211 E. Florence Ave.

Santa Fe Springs, CA 90670

Phone: 562-903-1168

Fax: 562-903-1167

[www.capital-cooking.com](http://www.capital-cooking.com)

[customerservice@capital-cooking.com](mailto:customerservice@capital-cooking.com)

Customer Service: 1-866-402-4600

**MADE IN USA**

As product improvement is an ongoing process, we reserve the right to change specifications or design without notice.

Litho in USA

Part No. 87000-10 **REV-01**