

This Owner's Manual is provided and hosted by [Appliance Factory Parts](http://ApplianceFactoryParts.com).

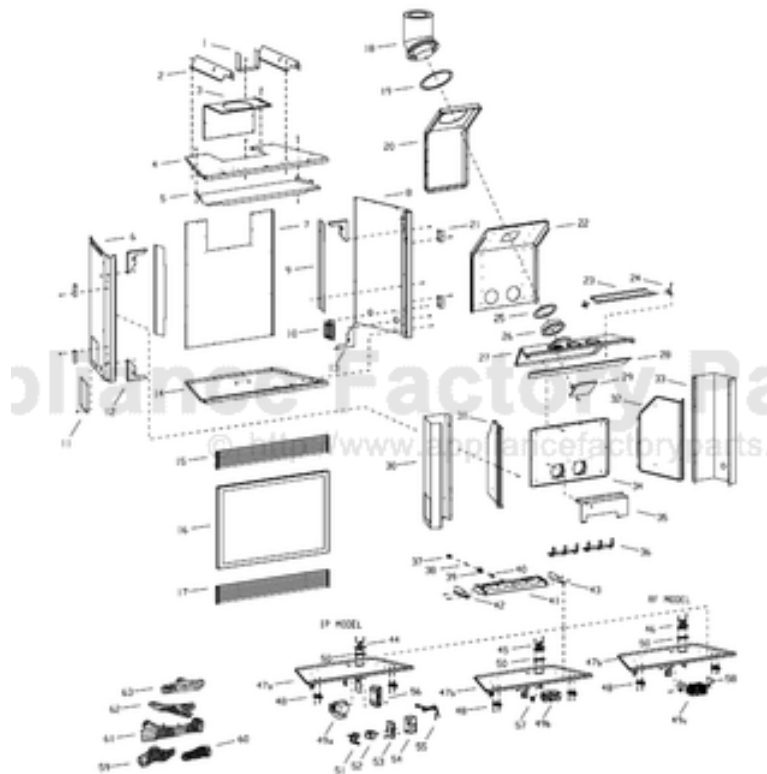

White Mountain Hearth DVS-42-2 Owner's Manual

[Shop genuine replacement parts for White Mountain
Hearth DVS-42-2](#)



[Find Your White Mountain Hearth Fireplace Parts - Select From 539 Models](#)

----- Manual continues below -----



INSTALLATION INSTRUCTIONS AND OWNER'S MANUAL

The *Tahoe* Direct Vent Gas Fireplaces

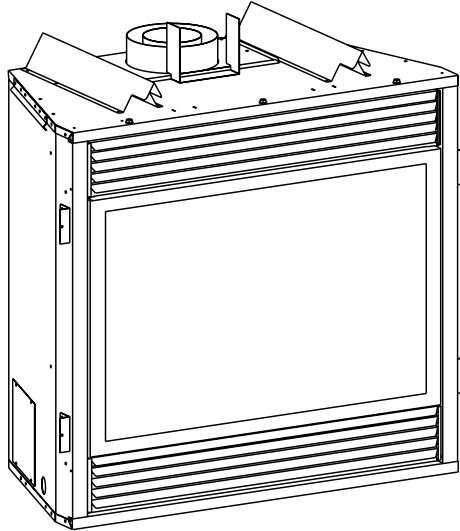

WARNING: If the information in this manual is not followed exactly, a fire or explosion may result causing property damage, personal injury or loss of life.

- Do not store or use gasoline or other flammable vapors and liquids in the vicinity of this or any other appliance.
- **WHAT TO DO IF YOU SMELL GAS**
 - Do not try to light any appliance.
 - Do not touch any electrical switch; do not use any phone in your building.
 - Immediately call your gas supplier from a neighbor's phone. Follow the gas supplier's instructions.
 - If you cannot reach your gas supplier, call the fire department.
- Installation and service must be performed by a qualified installer, service agency or the gas supplier.

DIRECT VENT GAS FIREPLACE

MODELS

DVS-30-2		DVS-30RF-2
DVS-36-2	DVS-36IP-2	DVS-36RF-2
DVS-42-2	DVS-42IP-2	DVS-42RF-2



EFFECTIVE DATE
FEBRUARY, 2003

This appliance may be installed in an aftermarket, permanently located, manufactured home (USA only) or mobile home, where not prohibited by state or local codes.

This appliance is only for use with the type of gas indicated on the rating plate. This appliance is not convertible for use with other gases, unless a certified kit is used.

WARNING: If not installed, operated and maintained in accordance with the manufacturer's instructions, this product could expose you to substances in fuel or from fuel combustion which can cause death or serious illness.

TABLE OF CONTENTS

Section	Page
Important Safety Information	3
Safety Information for Users of LP Gas	4
Introduction	5
Specifications	6
Fireplace Dimensions	6
Fireplace Component Installation	7
Clearances	8
Locating Fireplace	8
Gas Supply	9
Venting Fireplace	10
Installation	10-15
Termination Clearances	16
Vent Clearances	17
Vent System Identification	18
DVS-30 Framing and Finishing	19-20
DVS-36 & DVS-42 Framing and Finishing	21-22
Horizontal Termination (for all models)	22
Vertical Termination (for all models)	23-24
Log Placement	24-26
Standing Pilot Operating Instructions	26-28
Standing Pilot Wiring Diagram	28
Standing Pilot Lighting Instructions	29
Standing Pilot Troubleshooting	30
DVS-36 & DVS-42 Intermittent Pilot Operating Instructions	31
DVS-36 & DVS-42 Intermittent Pilot Wiring Diagram	31
DVS-36 & DVS-42 Intermittent Pilot Lighting Instructions	32
DVS-36 & DVS-42 Intermittent Pilot Troubleshooting	33-36
RF Standing Pilot Operating Instructions	37
RF Wiring Diagram with Optional Blower	38
RF Standing Pilot Lighting Instructions	39
Maintenance and Service	40
How to Order Repair Parts	41
DVS-30 Parts List	41
DVS-36 Parts List	42
DVS-42 Parts List	43
Parts View	44
Accessory Parts	45
Optional Variable Speed Blower Installation Instructions	46-47
Optional Single Speed Blower Installation Instructions	48-49
Optional Fresh Air Intake Installation Instructions	50-51
Optional Brick Liner Installation Instructions	52

IMPORTANT SAFETY INFORMATION

**Before enclosing the Simpson Dura-Vent vent pipe assembly
operate the appliance to ensure it is venting properly.**

DVS-36 OR DVS-42 IS A HEATING APPLIANCE WHEN HEATER BAFFLE IS INSTALLED, SEE PAGE 7

Do Not Operate This Appliance Without Glass Front Panel Installed.

- If this appliance is installed directly on carpeting, tile or other combustible material other than wood flooring the appliance shall be installed on a metal or wood panel extending the full width and depth of the appliance.

The base referred to above does not mean the fireproof base as used on wood stoves. The protection is for rugs that are extremely thick and light colored tile.
- Children and adults should be alerted to the hazards of high surface temperatures and should stay away to avoid burns or clothing ignition.
- Young children should be carefully supervised when they are in the same room as the appliance.
- Clothing or other flammable material should not be placed on or near the appliance.
- Adequate accessibility clearances for servicing and proper operation.
- This appliance must not share or be connected to a flue serving a separate solid-fuel burning appliance.
- Keep the area around your appliance clear of combustible materials, gasoline and other flammable vapor and liquids.
- Under no circumstances should any solid fuels (wood, coal, paper or cardboard etc.) be used in this appliance.
- The flow of combustion and ventilation air must not be obstructed in any way.

- Due to high temperatures the appliance should be located out of traffic and away from furniture and draperies.
- The glass front or any part removed for servicing the appliance must be replaced prior to operating the appliance. Work should be done by a qualified service person.
- Keep burner and control compartment clean.
- Vent cap is hot while fireplace is in operation.
- Installation and repair should be done by a **QUALIFIED SERVICE PERSON**. The appliance should be inspected before use and at least annually by a qualified service person. More frequent cleaning may be required due to excessive lint from carpeting, bedding materials, etc. It is imperative that control compartments, burners and circulating air passageways of the appliance be kept clean.
- **DO NOT** put anything around the fireplace that will obstruct the flow of ventilation air.
- **DO** keep the appliance area clear and free from combustible material, gasoline and other flammable vapors and liquids.
- **DO** examine venting system periodically and replace damaged parts.
- **DO** make a periodic visual check of pilot and burners. Clean and replace damaged parts.
- **CAUTION:** The glass used in your fireplace is tempered glass. If the glass is cracked or damaged in any way, it should be replaced only with a complete glass frame assembly from Empire. See parts list on Page 40-42 for ordering.
- **DO NOT** use this fireplace if any part has been under water. Immediately call a qualified service technician to inspect the heater and to replace any part of the control system and any gas control which has been under water.
- Any safety screen or guard removed for servicing an appliance must be replaced prior to operating the appliance.

SAFETY INFORMATION FOR USERS OF LP-GAS

Propane (LP-Gas) is a flammable gas which can cause fires and explosions. In its natural state, propane is odorless and colorless. You may not know all the following safety precautions which can protect both you and your family from an accident. Read them carefully now, then review them point

by point with the members of your household. Someday when there may not be a minute to lose, everyone's safety will depend on knowing exactly what to do. If, after reading the following information, you feel you still need more information, please contact your gas supplier.

LP-GAS WARNING ODOR

If a gas leak happens, you should be able to smell the gas because of the odorant put in the LP-Gas.

That's your signal to go into immediate action!

- Do not operate electric switches, light matches, use your phone. Do not do anything that could ignite the gas.
- Get everyone out of the building, vehicle, trailer, or area. Do that IMMEDIATELY.
- Close all gas tank or cylinder supply valves.
- LP-Gas is heavier than air and may settle in low areas such as basements. When you have reason to suspect a gas leak, keep out of basements and other low areas. Stay out until firefighters declare them to be safe.
- Use your neighbor's phone and call a trained LP-Gas service person and the fire department. Even though you may not continue to smell gas, do not turn on the gas again. Do not re-enter the building, vehicle, trailer, or area.
- **Finally**, let the service man and firefighters check for escaped gas. Have them air out the area before you return. Properly trained LP-Gas service people should repair the leak, then check and relight the gas appliance for you.

NO ODOR DETECTED - ODOR FADE

Some people cannot smell well. Some people cannot smell the odor of the chemical put into the gas. You must find out if you can smell the odorant in propane. Smoking can decrease your ability to smell. Being around an odor for a time can affect your sensitivity or ability to detect that odor. Sometimes other odors in the area mask the gas odor. People may not smell the gas odor or their minds are on something else. Thinking about smelling a gas odor can make it easier to smell.

The odorant in LP-gas is colorless, and it can fade under some circumstances. For example, if there is an underground leak, the movement of the gas through soil can filter the odorant. Odorants in LP-Gas also are subject to oxidation. This fading can

occur if there is rust inside the storage tank or in iron gas pipes.

The odorant in escaped gas can adsorb or absorb onto or into walls, masonry and other materials and fabrics in a room. That will take some of the odorant out of the gas, reducing its odor intensity.

LP-Gas may stratify in a closed area, and the odor intensity could vary at different levels. Since it is heavier than air, there may be more odor at lower levels. Always be sensitive to the slightest gas odor. If you detect any odor, treat it as a serious leak. Immediately go into action as instructed earlier.

SOME POINTS TO REMEMBER

- **Learn to recognize the odor of LP-gas.** Your local LP-Gas Dealer can give you a "Scratch and Sniff" pamphlet. Use it to find out what the propane odor smells like. If you suspect that your LP-Gas has a weak or abnormal odor, call your LP-Gas Dealer.
- If you are not qualified, do not light pilot lights, perform service, or make adjustments to appliances on the LP-Gas system. If you are qualified, consciously think about the odor of LP-Gas prior to and while lighting pilot lights or performing service or making adjustments.
- Sometimes a basement or a closed-up house has a musty smell that can cover up the LP-Gas odor. Do not try to light pilot lights, perform service, or make adjustments in an area where the conditions are such that you may not detect the odor if there has been a leak of LP-Gas.
- Odor fade, due to oxidation by rust or adsorption on walls of new cylinders and tanks, is possible. Therefore, people should be particularly alert and careful when new tanks or cylinders are placed in service. Odor fade can occur in new tanks, or reinstalled old tanks, if they are filled and allowed to set too long before refilling. Cylinders and tanks which have been out of service for a time may develop internal rust which will cause odor fade. If such conditions are suspected to exist, a periodic sniff test of the gas is advisable. **If you have any question about the gas odor, call your LP-gas dealer. A periodic sniff test of the LP-gas is a good safety measure under any condition.**
- If, at any time, you do not smell the LP-Gas odorant and you think you should, assume you have a leak. Then take the same immediate action recommended above for the occasion when you do detect the odorized LP-Gas.
- If you experience a complete "gas out," (the container is under no vapor pressure), turn the tank valve off immediately. If the container valve is left on, the container may draw in some air through openings such as pilot light orifices. If this occurs, some new internal rusting could occur. If the valve is left open, then treat the container as a new tank. Always be sure your container is under vapor pressure by turning it off at the container before it goes completely empty or having it refilled before it is completely empty.

INTRODUCTION

Instructions to Installer

1. Installer must leave instruction manual with owner after installation.
2. Installer must have owner fill out and mail warranty card supplied with the fireplace.
3. Installer should show owner how to start and operate the fireplace.

This direct vent gas fireplace is designed to operate with all combustion air being siphoned from the outside of the building and all exhaust gases expelled to the outside of the building. The information contained in this manual pertains to all models and gas control systems unless otherwise noted.

Warning: This unit is not for use with solid fuel.

Approval Listings and Codes

Appliance Certification

This fireplace is design certified in accordance with American National Standard/CSA Standard Z.21.88b-2001/CSA 2.33b-2001 and Z21.50b-2002/CSA 2.2b-2002 by UL/CUL Laboratories as a Direct Vent Gas Fireplace Heater/Direct Vent Gas Fireplace and should be installed according to these instructions.

Consult your local building code agency, prior to installation, to ensure compliance with local codes-including permits and inspections.

The fireplace, when installed, must be electrically grounded in accordance with local codes or, in absence of local codes, with the *National Electric Code ANSI/NFPA 70* or Canadian Electric code, CSA C22.1, if an external electrical source is utilized.

These models may be installed in a bedroom or bed-sitting room in the U.S.A. and Canada.

Qualified Installing Agency

Installation and replacement of gas piping, gas utilization equipment or accessories and repair and servicing of equipment shall be performed only by a qualified agency. The term "qualified agency" means any individual, firm, corporation or company which either in person or through a representative is engaged in and is responsible for (a) the installation or replacement of gas piping or (b) the connection, installation, repair or servicing of equipment, who is experienced in such work, familiar with all precautions required and has complied with all the requirements of the authority having jurisdiction.

State of Massachusetts: The installation must be made by a licensed plumber or gas fitter in the Commonwealth of Massachusetts.

The installation must conform with local codes or, in the absence of local codes, with the *National Fuel Gas Code ANSI Z223.1/NFPA 54* Natural Gas and Propane Installation Code, CSA B149.1.*

*Available from the American National Standards Institute, Inc. 11 West 42nd St., New York, N.Y. 10036.

WARNING: ANY CHANGE TO THIS FIREPLACE OR ITS CONTROLS CAN BE DANGEROUS.

Improper installation or use of the heater can cause serious injury or death from fire, burns, explosion or carbon monoxide poisoning.

Any alteration of the original design, installed other than as shown in these instructions or use with a type of gas not shown on the rating plate is the responsibility of the person and company making the change.

Important

All correspondence should refer to complete Model Number, Serial Number and type of gas.

Installation in Residential Garages

Gas utilization equipment in residential garages shall be installed so that all burners and burner ignition devices are located not less than 18" (457mm) above the floor.

Such equipment shall be located, or protected, so it is not subject to physical damage by a moving vehicle.

High Altitude

When installing this unit at an elevation above 2000 feet (in the United States) it may be necessary to decrease the input rating by changing the existing burner orifice to a smaller size. Generally, input should be reduced 4 percent for each 1000 feet above sea level. However, if the heating value of the gas has been reduced, this general rule may not apply. Check with local gas utility for proper orifice size identification.

Canadian High Altitude

Altitude: 0-4500 feet (0-1370 m)

APPLIES TO CANADIAN MODELS ONLY

When installing this unit at an elevation above 4500 feet (in Canada), check with local authorities.

Consult your local gas utility for assistance in determining the proper orifice for location.

Preparation

This direct vent gas fireplace and its components are tested and safe when installed in accordance with this Installation Manual. Report to your dealer any parts damaged in shipment, specifically check glass condition. Do not install unit with damaged, incomplete, or substitute parts. The vent system components and trim doors are shipped in separate packages. Read all instructions before starting installation and follow these instructions carefully during installation to insure maximum benefit and safety. Failure to follow them will void your warranty and may present a fire hazard.

The warranty will be voided by, and the warranter disclaims any responsibility for the following actions:

- Installation of any damaged fireplace or vent system component.
- Modification of the fireplace or direct vent system.
- Installation other than as instructed by Empire Comfort System, Inc.
- Improper positioning of the gas logs, glass door or lava rock.
- Installation and/or use of any component part not manufactured or approved by manufacturer.

SPECIFICATIONS

Model	DVS-30(RF)	DVS-36(RF)	DVS-36IP	DVS-42(RF)	DVS-42IP
Input BTU/HR (KW/H) Maximum	20,000 (5.9)	25,000 (7.3)	25,000 (7.3)	28,000 (8.2)	28,000 (8.2)
BTU/HR (KW/H) Minimum	14,000 (4.1)	17,500 (5.1)	—	20,000 (5.9)	—
Height without standoff	34 1/4"	36 1/4"	36 1/4"	38 1/4"	38 1/4"
Width	33"	39"	39"	45"	45"
Depth	16 1/4"	21"	21"	24"	24"
Gas Inlet (Pipe)	3/8"	3/8"	1/2"	3/8"	1/2"

Control Options & Accessories for All DVS-30, DVS-36 & DVS-42	
GWSG-T	750 Millivolt Wall Thermostat (Only used when DVS-36 or DVS-42 fireplace is converted into a heater.)
FRBC-1	Battery Operated Remote Control
FRBTC-1	Battery Operated Remote Control with Thermostat (Only used when DVS-36 or DVS-42 fireplace is converted into a heater)
FREC-1	Electric Remote Control
FWS-1	Wall Switch
EK-1	Embers Kit
FB-BK-2	Variable Speed Automatic Blower
FBB1A	Single Speed Automatic Blower
FBJB-1	Junction Box (for non-IP models only)

Venting Options for All DVS-30	
DVVK-4T-1	Direct Vent Fireplace Vent Kit (Top Vent) (standard through the wall venting) (Includes SD-990B SD-911B, SD-985, SD-947)
DVVK-4R-1	Direct Vent Fireplace Vent Kit (Rear Vent) (standard through the wall venting) (Includes SD-908, SD-947, SD-985)
Venting Options for All DVS-36 & DVS-42	
DVVK-5T-1	Direct Vent Fireplace Vent Kit (Top Vent) (standard through the wall venting) (Includes SD-1208, SD-1284, SD-1290 and Firestop)
DVVK-5R-1	Direct Vent Fireplace Vent Kit (Rear Vent) (standard through the wall venting) (Includes SD-1208, SD-1284 and Firestop)

DVS-30 Accessories Only	
DVFB-AK-30	Kit for Fresh Air Plus
DVS-BL-30-2	Brick Liner
DVPIA-30-1	Ceramic Aged Brick Liner
FBF-30BL-2	Black Frame
DVFBF-30BR-1	Polished Brass Frame
FBF-30BP-2	Black Porcelain Frame
FBL-30BR-2	Polished Brass Louvers
FBL-30BP-2	Black Porcelain Louvers
DVWT-30BR	Brass Window Trim

DVS-36 Accessories Only	
FB-AK-2	Kit for Fresh Air Plus
DVS-BL-36-2	Brick Liner
DVPIA-36-1	Ceramic Aged Brick Liner
FBF-36BL-2	Black Frame
DVFBF-36BR-1	Polished Brass Frame
FBF-36BP-2	Black Porcelain Frame
FBL-36BR-2	Polished Brass Louvers
FBL-36BP-2	Black Porcelain Louvers
DVWT-36BR	Brass Window Trim

DVS-42 Accessories Only	
FB-AK-2	Kit for Fresh Air Plus
DVS-BL-42-2	Brick Liner
DVPIA-42-1	Ceramic Aged Brick Liner
FBF-42BL-2	Black Frame
DVFBF-42BR-1	Polished Brass Frame
FBF-42BP-2	Black Porcelain Frame
FBL-42BR-2	Polished Brass Louvers
FBL-42BP-2	Black Porcelain Louvers
DVWT-42BR	Brass Window Trim

FIREPLACE DIMENSIONS MODEL DVS-30/DVS-36/DVS-42

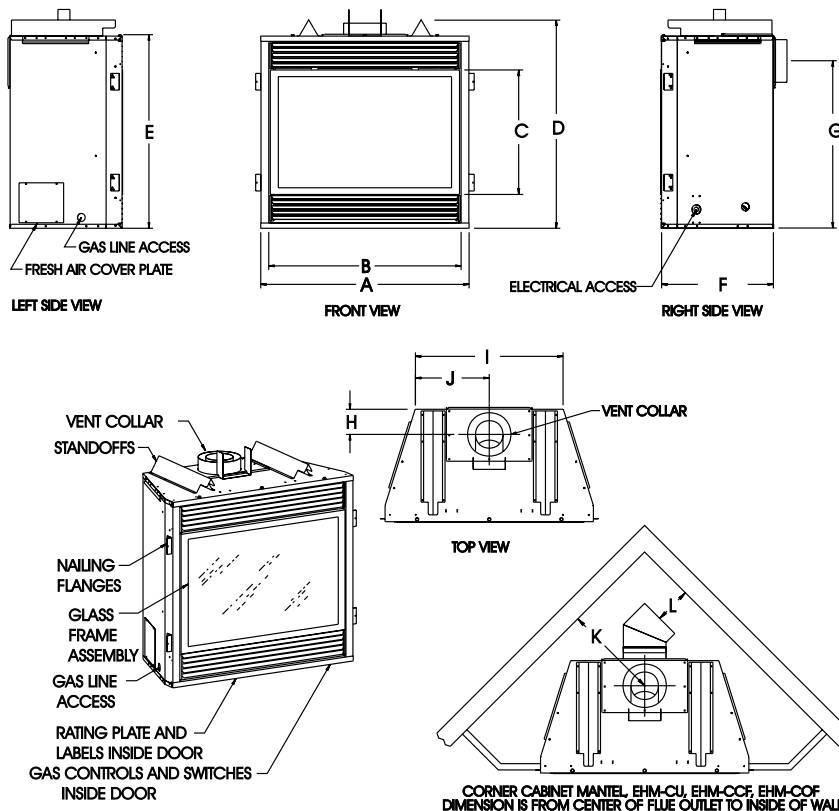

DIM	DVS-30	DVS-36	DVS-42
A	33" 84cm	39" 99cm	45" 114cm
B	30" 76cm	36" 91cm	42" 107cm
C	20" 508mm	22" 559mm	24" 610mm
D	37 1/4" 95cm	39" 99cm	41" 104cm
E	34 1/2" 88cm	36 1/4" 92cm	38 1/4" 97cm
F	16 1/4" 413mm	21" 533mm	24" 610mm
G	29 5/8" 753mm	31 1/2" 800mm	33 1/2" 851mm
H	4 3/4" 121mm	4 3/4" 121mm	4 3/4" 121mm
I	25 3/8" 645mm	27 3/4" 705mm	32" 813mm
J	12 11/16" 322mm	13 7/8" 352mm	16" 406mm
K	15 1/2" 394mm	15 1/2" 394mm	N/A
L	4 1/2" 114mm	3 11/16" 94mm	N/A

Figure 1

FIREPLACE COMPONENT INSTALLATION

Installation of Upper Clearance Spacer for Vertical Vent (Figure 2)

Included with every fireplace is the upper clearance spacer. The upper clearance spacer must be attached to the top of the firebox before installation of fireplace in a vertical vent configuration.

1. Remove screw in firebox top that is behind 1/4" flange on vent cover plate and directly in front of adapter pipe.
2. Place the notched portion of upper clearance spacer facing the 1/4" flange on vent cover plate.
3. Flex firebox top and slide upper clearance spacer beneath vent cover plate.
4. Attach upper clearance spacer to firebox top with screw from Step 1.
5. Installation of upper clearance spacer is completed.

The upper clearance spacer will prevent combustible material from contacting adapter pipe.

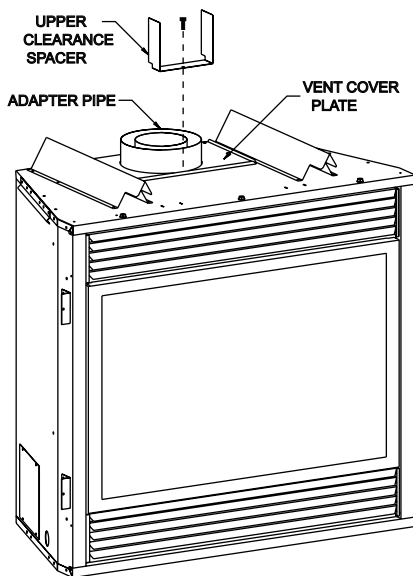

Figure 2

Installation of Heater Baffle for DVS-36 or DVS-42 (Figure 3)

Your DVS-36 or DVS-42 fireplace is a direct vent gas fireplace. To convert your direct vent gas fireplace into a direct vent gas fireplace heater you will install the heater baffle into the fireplace.

The heater baffle, part number 10993 is included with every DVS-36 or DVS-42.

Attention: For DVS-36/42 only, Propane (LP) gas, on horizontal, straight out rear installation, the heater baffle shall not be used. The DVS-36/42 must remain a decorative appliance.

Installation of heater baffle:

1. Push up and outward to remove top louver.
2. Lower door assembly.
3. Release two door latches at bottom of firebox.
4. Grasp bottom of glass frame, lift glass frame upward in order to release glass frame from lip on top of firebox.
5. Insert heater baffle into interior, top of fireplace. The heater baffle will be installed in front of 5" diameter vent outlet. Align two (2) clearance holes on heater baffle with two (2) screws within interior, top of fireplace. Remove two (2) screws from fireplace.
6. Attach heater baffle to interior, top of fireplace with two (2) screws from Step 5.
7. Align and place top of glass frame over lip on top of firebox.
8. Grasp bottom of glass frame, push inward and place glass frame onto firebox.
9. Attach two door latches onto bottom of glass frame.
10. Align and insert (4) mounting tabs on top louver with (4) slots on casing top. Push downward to lock the top louver into position.
11. Installation of heater baffle is completed.

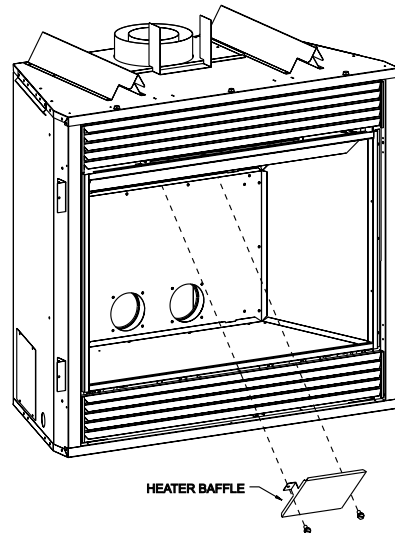

HEATER BAFFLE IS USED ON DVS-36 & DVS-42 ONLY

Figure 3

Reversible Vertical or Horizontal Adapter Pipe (Figure 4)

This fireplace has a reversible adapter pipe. The adapter pipe is installed in the vertical position at the factory. Use the following steps to change the adapter pipe from the vertical position to the horizontal position.

1. Remove screws from vent cover.
2. Lift upward to remove vent cover from adapter pipe.
3. Grasp adapter pipe and rotate adapter pipe clockwise to the horizontal position.
4. Replace vent cover over adapter pipe. Attach vent cover with screws from Step 1.
5. Repositioning of the adapter pipe is completed.

Adapter Pipe Vertical Outlet

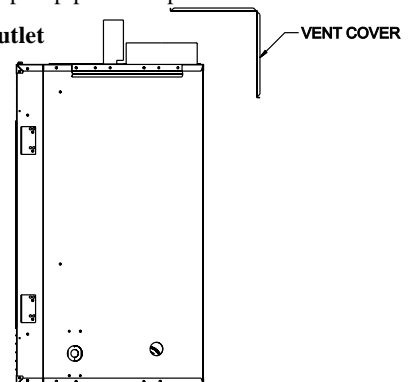

Adapter Pipe Horizontal Outlet

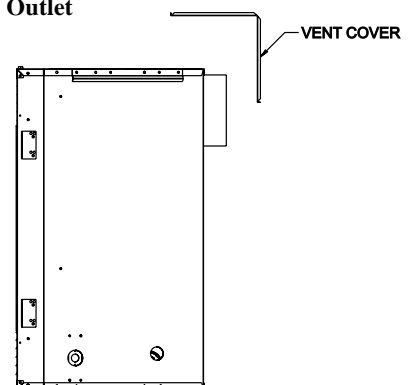

Figure 4 TOP STANDOFFS REMOVED FOR CLARITY

CLEARANCES

CLEARANCES TO COMBUSTIBLES	
BACK SPACER	0" (0MM)
SIDE SPACER	0" (0MM)
FLOOR	0" (0MM)
TOP STAND OFF	0" (0MM)
TOP FRAMING LEDGE	0" (0MM)

Mantel Chart (Figure 6)

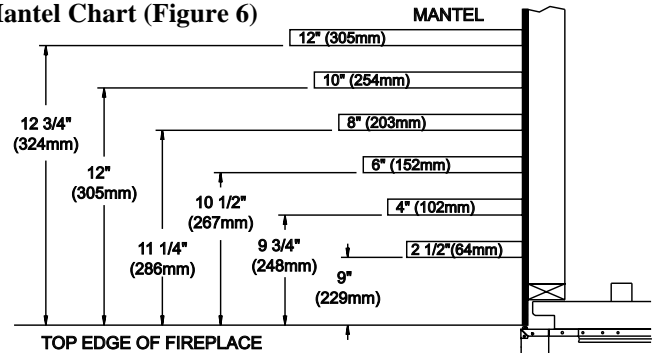

Figure 6

Clearances (Figure 7)

Clearance from top of fireplace to ceiling is 36"
Clearance from side of fireplace to adjacent sidewall is 6".

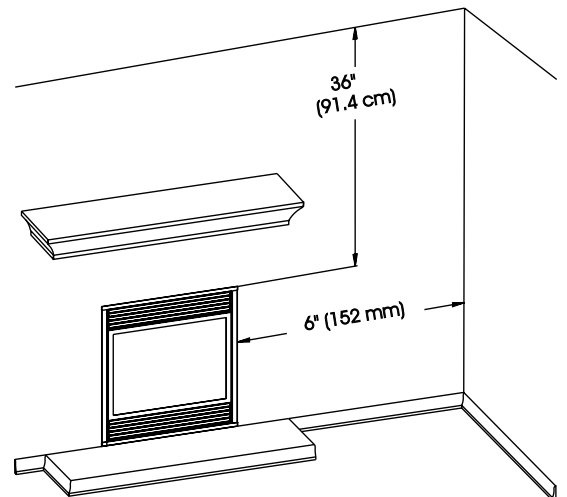

Figure 7

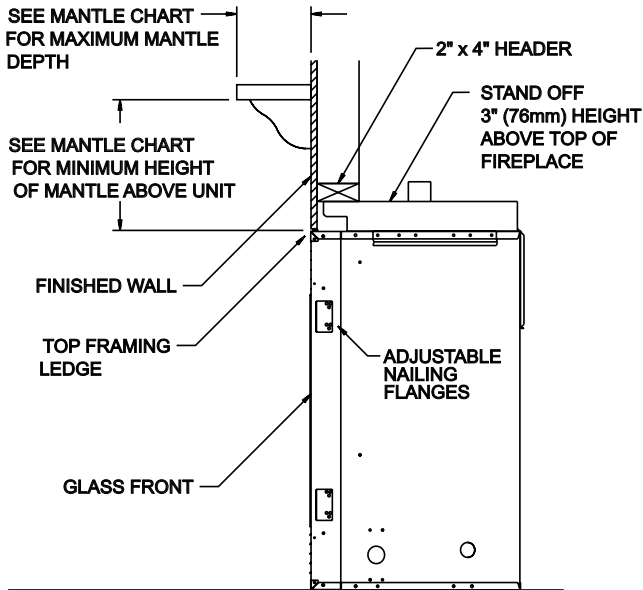

Figure 5

Combustible Material

No greeting cards, stockings or ornamentation of any type should be placed on or attached to the fireplace. The flow of heat can ignite combustibles.

LOCATING FIREPLACE

Note:** Island (C) and Room Divider (D) installation is possible as long as the horizontal portion of the vent system (H) does not exceed 20 feet with a minimum vertical run of 8 feet. See details in Venting Section.

*When you install your Direct Vent Fireplace in (D) Room divider or (E) Flat on wall corner positions, a minimum of 6 inches clearance must be maintained from the perpendicular wall and the front edge of the appliance.

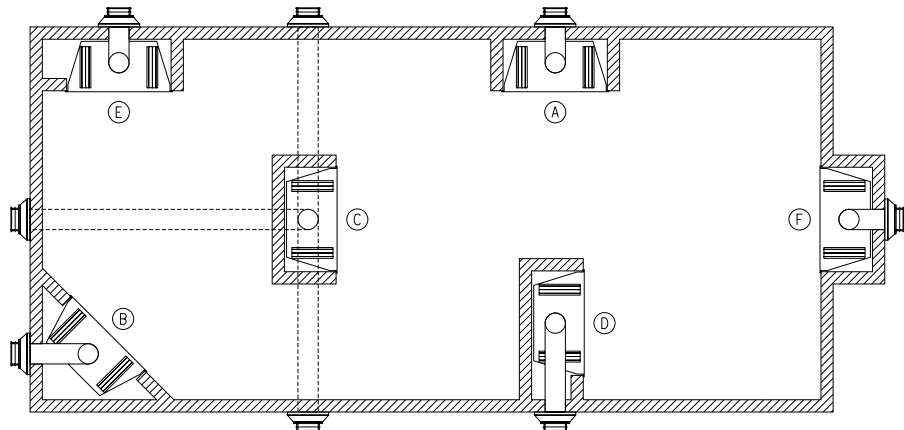

Figure 8

GAS SUPPLY

The gas pipeline can be brought in through the right or left side of the appliance. Consult the current National Fuel Gas Code, ANSI Z223.1 CAN/CGA-B149 (.1 or .2) installation code.

Recommended Gas Pipe Diameter

Pipe Length (Feet)	Schedule 40 Pipe Inside Diameter		Tubing, Type L Outside Diameter	
	Nat.	L.P.	Nat.	L.P.
0-10	1/2" 1.3 cm	3/8" 1.0 cm	1/2" 1.3 cm	3/8" 1.0 cm
10-40	1/2" 1.3 cm	1/2" 1.3 cm	5/8" 1.6 cm	1/2" 1.3 cm
40-100	1/2" 1.3 cm	1/2" 1.3 cm	3/4" 1.9 cm	1/2" 1.3 cm
100-150	3/4" 1.9 cm	1/2" 1.3 cm	7/8" 2.2 cm	3/4" 1.9 cm

Note: Never use plastic pipe. Check to confirm whether your local codes allow copper tubing or galvanized.

Note: Since some municipalities have additional local codes, it is always best to consult your local authority and installation code.

The use of the following gas connectors is recommended:

- ANS Z21.24 Appliance Connectors of Corrugated Metal Tubing and Fittings
- ANS Z21.45 Assembled Flexible Appliance Connectors of Other Than All-Metal Construction

The above connectors may be used if acceptable by the authority having jurisdiction. The state of Massachusetts requires that a flexible appliance connector cannot exceed three feet in length.

Consult the current National Fuel Gas Code, ANSI Z223.1 CAN/CGA-B149 (.1 or .2) installation code.

Installing a New Main Gas Cock

Each appliance should have its own manual gas cock.

In the state of Massachusetts the gas cock must be a T handle type.

A manual main gas cock should be located in the vicinity of the unit. Where none exists, or where its size or location is not adequate, contact your local authorized installer for installation or relocation.

Compounds used on threaded joints of gas piping shall be resistant to the action of liquefied petroleum gases. The gas lines must be checked for leaks by the installer. This should be done with a soap solution watching for bubbles on all exposed connections, and if unexposed, a pressure test should be made.

Never use an exposed flame to check for leaks. Appliance must be disconnected from piping at inlet of control valve and pipe capped or plugged for pressure test. Never pressure test with appliance connected; control valve will sustain damage!

NOTE: The gas control is equipped with a captured screw type pressure test point, therefore it is not necessary to provide a 1/8" test point up stream of the control.

A gas valve and ground joint union should be installed in the gas line upstream of the gas control to aid in servicing. It is required by the National Fuel Gas Code that a drip line be installed near the gas inlet. This should consist of a vertical length of pipe tee connected into the gas line that is capped on the bottom in which condensation and foreign particles may collect.

When using copper or flex connector use only approved fittings. **Always provide a union** so that gas line can be easily disconnected for burner or fan servicing. See gas specification for pressure details and ratings.

The appliance and it's individual shut off valve must be disconnected from supply piping system during any pressure testing of that system at test pressures in excess of 1/2 psig (3.5kPa).

The appliance must be isolated from the gas supply piping system by closing its individual manual shut off valve during any pressure testing of the gas supply piping system at test pressures equal to or less than 1/2 psig (3.5kPa).

Attention! If one of the procedures results in pressures in excess of 1/2 psig (14" w.c.) (3.5 kPa) on the fireplace gas valve, it will result in a hazardous condition.

Checking Manifold Pressures

Both Propane and Natural gas valves have a built-in pressure regulator in the gas valve. Natural gas models will have a manifold pressure of approximately 3.5" w.c. (.871kPa) at the valve outlet with the inlet pressure to the valve from a minimum of 4.5" w.c. (1.120kPa) for the purpose of input adjustment to a maximum of 10.5" w.c. (2.615kPa). Propane gas models will have a manifold pressure approximately 10.0" w.c. (2.49kPa) at the valve outlet with the inlet pressure to the valve from a minimum of 11.0" w.c. (2.739kPa) for the purpose of input adjustment to a maximum of 13.0" w.c. (3.237kPa).

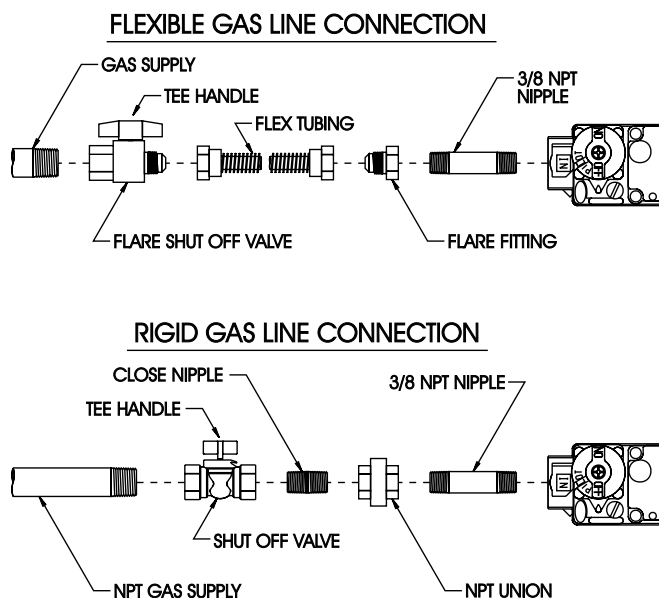

Figure 9

VENTING FIREPLACE

To Use the Vent Graph (Figure 10)

1. Determine the height of the center of the horizontal vent pipe. Using this dimension on the Sidewall Vent Graph, locate the point it intersects with the slanted graph line.
2. From the point of this intersection, draw a vertical line to the bottom of the graph.
3. Select the indicated dimension, and position the unit in accordance with same.

EXAMPLE A:

If the vertical dimension from the floor of the unit is 22.5 feet, the horizontal run to the outer wall flange must not exceed 6.5 feet.

EXAMPLE B:

If the vertical dimension from the floor of the unit is 6.5 feet, the horizontal run to the outer wall flange must not exceed 14.5 feet.

SPECIAL NOTE: For each 45 degree elbow installed in the horizontal run, the length of the horizontal run **MUST** be reduced by 18" (45cm). This does not apply if the 45 degree elbows are installed on the vertical part of the vent system.

Example: According to the chart the maximum horizontal vent length is 20' and if two 45 degree elbows are required in the horizontal vent it must be reduced to 17'.

The maximum number of 45 degree elbows permitted per side wall installation is two (2). These elbows can be installed in either the vertical or horizontal run.

Venting Graph (Dimensions in Feet)

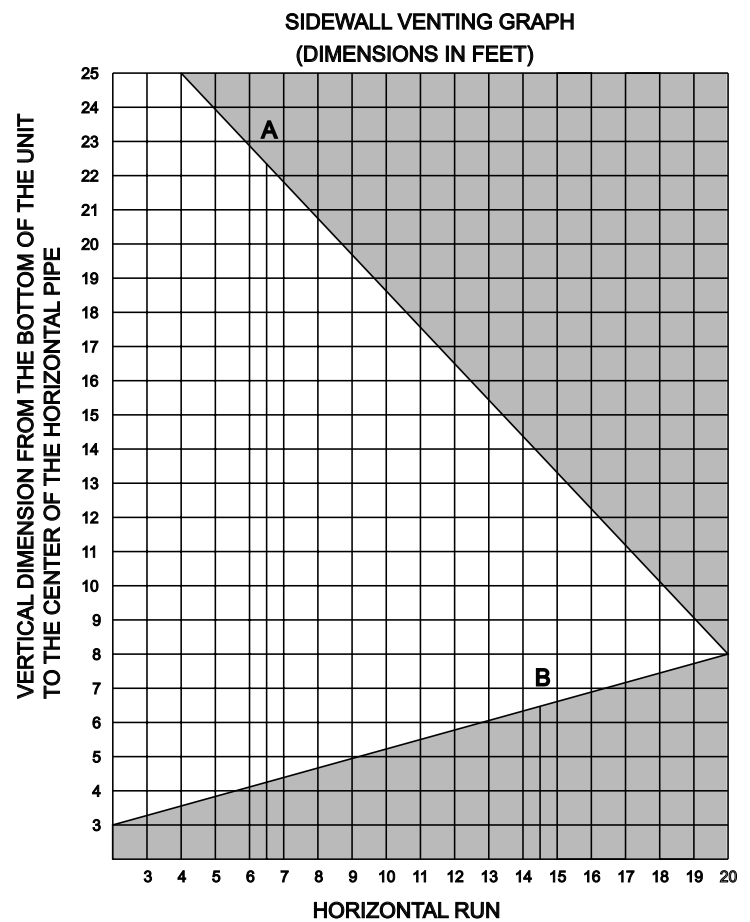

Figure 10

- Acceptable vertical and horizontal vent run.
- Unacceptable vertical and horizontal vent run.

INSTALLATION

Framing and Finishing

1. Choose unit location.
2. Frame in fireplace with a header across the top. It is important to allow for finished face when setting the depth of the frame.
3. Attach fireplace to frame using adjustable frame. Preset depth to suit facing material (adjustable to 1/2", 5/8" or 3/4" depths).
4. Use (8) 1/2" hex-head screws supplied in hardware package, to screw through slotted holes in drywall strip and then screw into pre-drilled holes on fireplace side. Measure from face of fireplace to face of drywall strip to determine final depth.

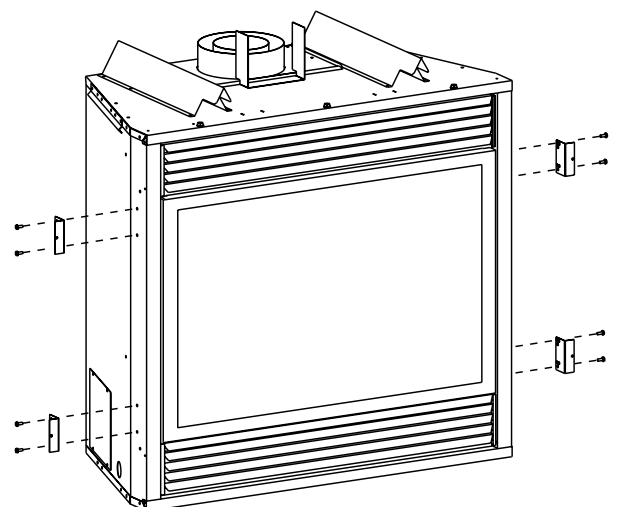

DVS-36/42 Shown

Figure 11

Attention: When fireplace is installed in optional full cabinet mantel or corner mantel the (4) four nailing flanges shown in Figure 11 will not be installed on the side of outer casing. The DVS will be attached to the full cabinet mantel or corner mantel with the (2) two nailing flanges located on the top of the outer casing assembly.

Framing (Figure 12)

Fireplace framing can be built before or after the fireplace is set in place. Framing should be positioned to accommodate wall covering and fireplace facing material. The fireplace framing should be constructed of 2 x 4 lumber or heavier. The framing headers may rest on the fireplace standoffs. Refer to Figure 12 for framing reference dimensions.

CAUTION: MEASURE FIREPLACE DIMENSIONS AND VERIFY FRAMING METHODS, AND WALL COVERING DETAILS BEFORE FRAMING CONSTRUCTION BEGINS.

Framing dimension A includes a three inch clearance for standoffs on firebox. After installing firebox into framing, the finished wall surface must cover the three inch opening above the firebox.

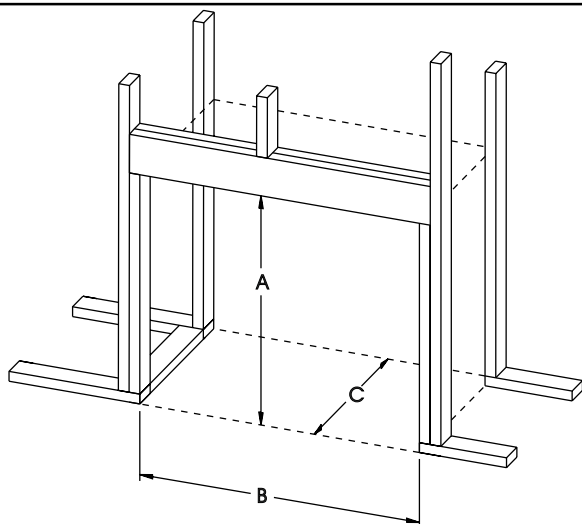

	30	36	42
"A"	37 1/2"	39 1/4"	41 1/4"
"B"	33 3/4"	39 1/4"	45 1/4"
"C"	16 1/2"	21 1/4"	24 1/4"

Figure 12

Attention: If a base or mantel is not used and the appliance is installed directly on carpeting, tile or other combustible material other than wood flooring, it shall be installed on a metal or wood panel extending the full width and depth of the appliance. The vertical dimension in Figure 12 must be adjusted when a metal or wood panel is placed beneath the appliance.

Finishing (Figure 13)

Finish the walls with the material of your choice. Figure 6 shows the minimum vertical and corresponding maximum horizontal dimensions of mantels or other combustible projections above the top front edge of the fireplace.

Only non-combustible materials may be used to cover the black fireplace front.

WARNING: When finishing the fireplace never obstruct or modify the air inlet/outlet louvers in any manner. Provide adequate clearances around air openings into the combustion chamber.

Caution: If the joints between the finished wall and the fireplace surround (top and sides) are sealed, a 300°F minimum sealant material must be used. These joints are not required to be sealed. Only non-combustible material (using 300°F minimum adhesive if needed), can be applied as facing to the fireplace surround.

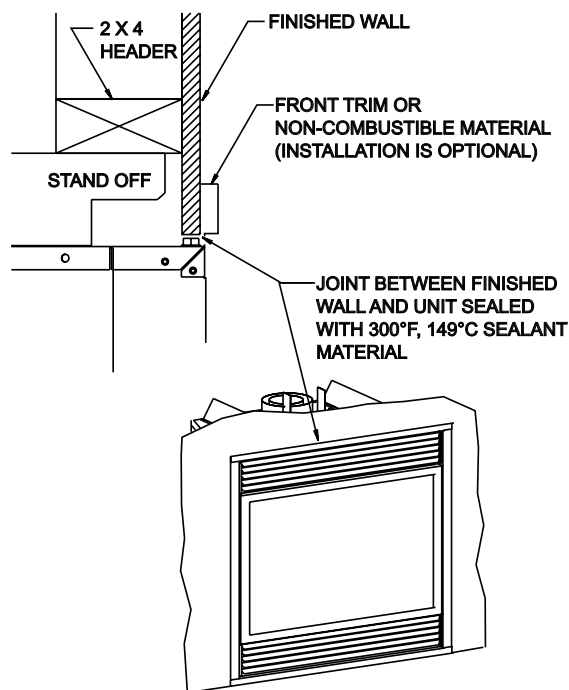

Figure 13

Attention: Cold climate installation recommendation: When installing this unit against a non-insulated exterior wall, it is mandatory that the outer walls be insulated to conform to applicable insulation codes.

Vent Runs (Figures 14, 15, 16, 17 and 18)

In planning the installation for the fireplace, it is necessary to install certain components before the appliance is completely positioned and installed. These include the direct vent system, gas piping for the appliance and the electrical wiring. (If the fan option is used.)

The appliance can be mounted on any of the following surfaces:

1. A flat, hard combustible (burnable) surface.
2. A raised wooden platform.
3. Four (4) corner supports. (Example: Four (4) concrete masonry blocks.) These supports must be positioned so they contact all four (4) perimeter edges on the bottom of the unit.

Three (3) basic types of installations

1. Straight out (4" - 8" wall thickness).
2. Extended straight out (8" - 36" wall thickness).
3. Vertical installations.

INSTALLATION (continued)

VERTICAL, 90° ELBOW WITH HORIZONTAL TERMINATION

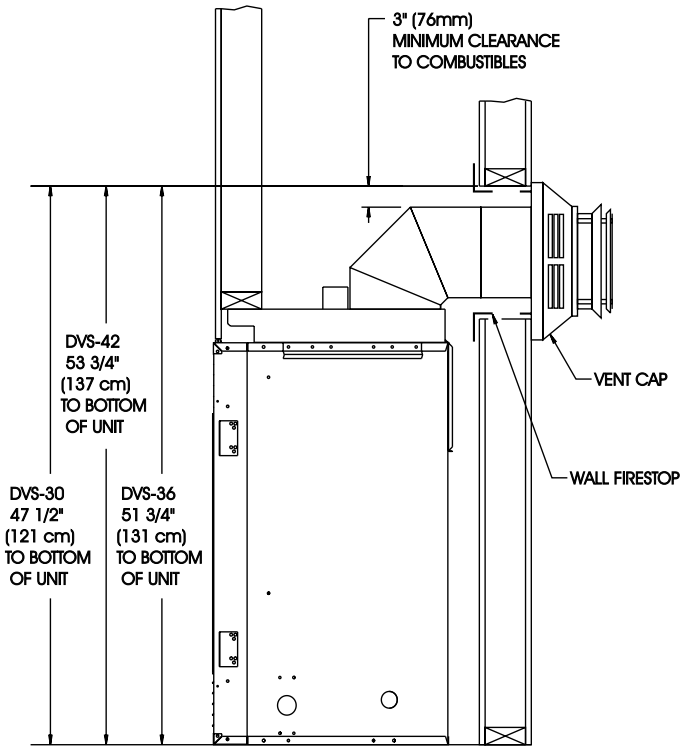
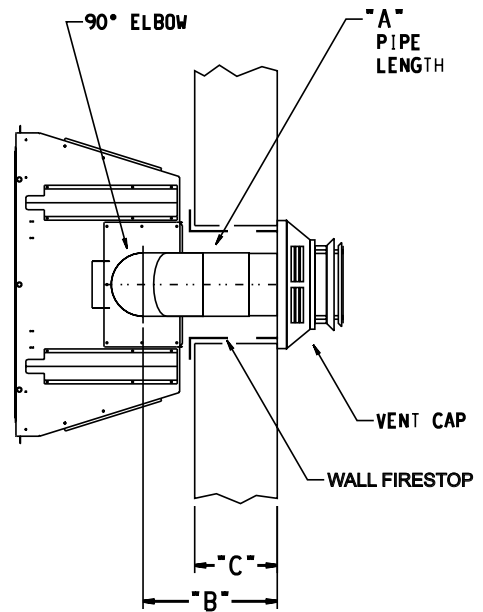

Figure 14

VERTICAL, 90° ELBOW TO HORIZONTAL OUT THE WALL



"A"	"B"	"C"
6" 152mm	9 7/16" TO 10 9/16" 240mm TO 268mm	4" TO 5 1/8" 102mm TO 130mm
9" 229mm	10 13/16" TO 13 9/16" 275mm TO 344mm	5 5/8" TO 8 1/8" 143mm TO 206mm
12" 305mm	14" TO 16 9/16" 356mm TO 421mm	8 5/8" TO 11 1/8" 219mm TO 283mm

Figure 16

HORIZONTAL ONLY, STRAIGHT OUT THE BACK

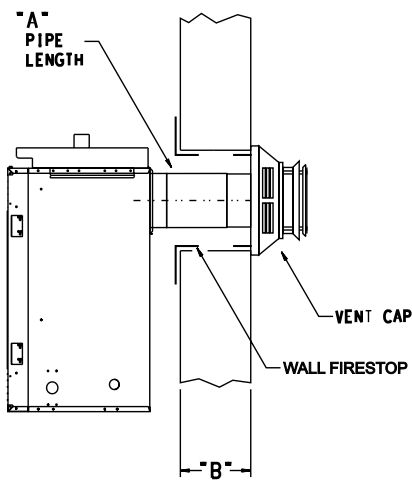

"A"	"B"
NO PIPE	4" TO 5 5/8" 102mm TO 143mm
6" 152mm	5 5/8" TO 11 5/8" 143mm TO 295mm
9" 229mm	11 1/8" TO 14 5/8" 283mm TO 371mm
12" 305mm	14 1/8" TO 17 5/8" 359mm TO 448mm

Figure 15

CORNER INSTALLATION VERTICAL, 90° ELBOW TO HORIZONTAL OUT THE WALL

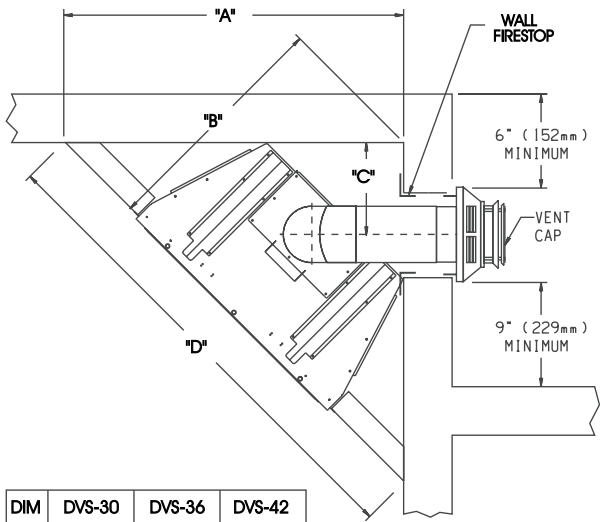

DIM	DVS-30	DVS-36	DVS-42
"A"	39 3/4" 101cm	48 5/8" 124cm	55 7/8" 142cm
"B"	28 1/8" 71cm	34 1/2" 88cm	39 5/8" 101cm
"C"	12 1/8" 308mm	13 1/4" 337mm	14 3/4" 375mm
"D"	56 1/4" 143cm	69 1/8" 176cm	79 1/4" 201cm

Figure 17

CORNER INSTALLATION HORIZONTAL, 45° ELBOW TO HORIZONTAL OUT THE WALL

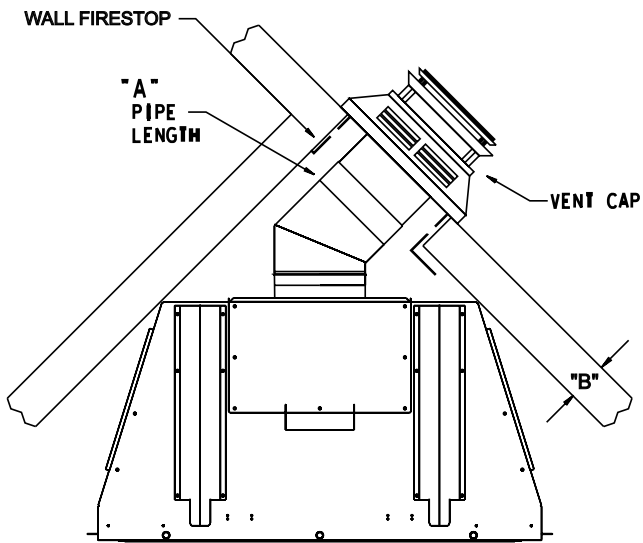

"A"	"B"
6" 152mm	4" TO 7 1/2" 102mm TO 191mm
9" 229mm	7 5/8" TO 10 5/8" 194mm TO 270mm

Figure 18

Vertical Sidewall Application

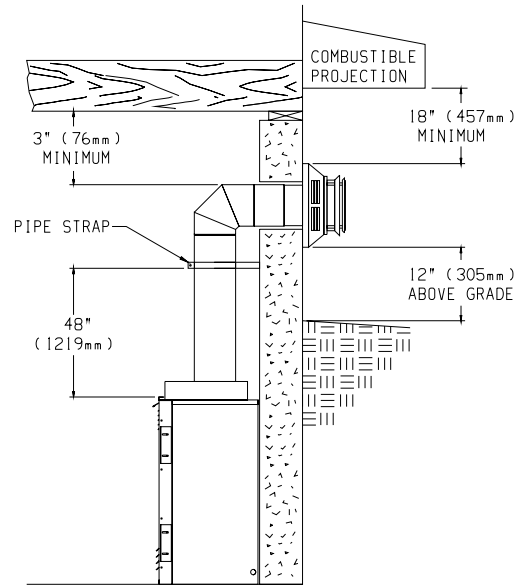

TYPICAL BASEMENT INSTALLATION

Figure 19

Figure 20 and Chart 1 lists examples of possible venting systems using one (1) 90° elbow. Eight (8) feet is listed as maximum vertical vent run with 20 feet of maximum horizontal vent run. Vertical dimensions are based on centerline to centerline of pipe. Horizontal dimensions are based on centerline of pipe to end of termination.

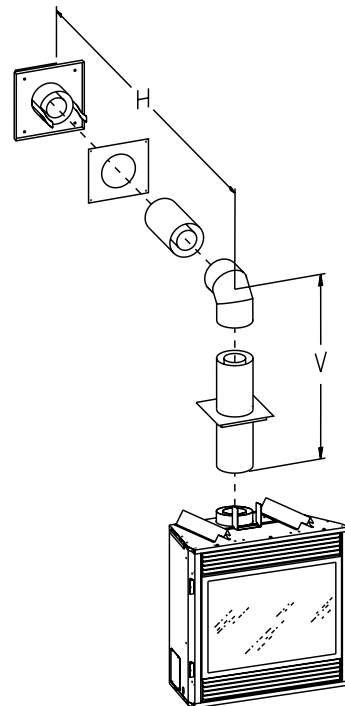

SEE CHART FOR PERMISSIBLE "H" AND "V" DIMENSIONS

Figure 20

INSTALLATION (continued)

CHART 1 (Figures 20 and 21)

Venting with One (1) 90° Elbow or Two (2) 90° Elbows

Total Vertical (With Fire Box) V	Total Horizontal H ¹ or H ¹ + H ²
4.5' minimum	3' maximum
4.5' minimum	4' maximum
5' minimum	8' maximum
6' minimum	12' maximum
7' minimum	15' maximum
8' minimum	20' maximum
25' maximum vertical	
20' maximum horizontal run	

Figure 21 and Chart 1 list examples of possible venting systems using two (2) 90° elbows. V is listed as minimum vertical dimensions and H¹ + H² is listed as total of maximum horizontal dimensions. The maximum vertical and horizontal distances for two (2) 90° elbows as shown in Figure 21 are 20 feet.

Attention: Refer to Figure 10 for additional venting requirements.

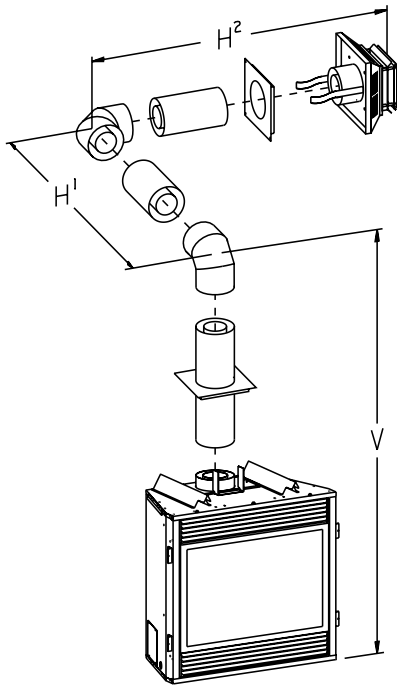

SEE CHART FOR PERMISSIBLE "H" AND "V" DIMENSIONS
NOTE: H1 AND H2 MUST BE ADDED TOGETHER TO USE CHART

Figure 21

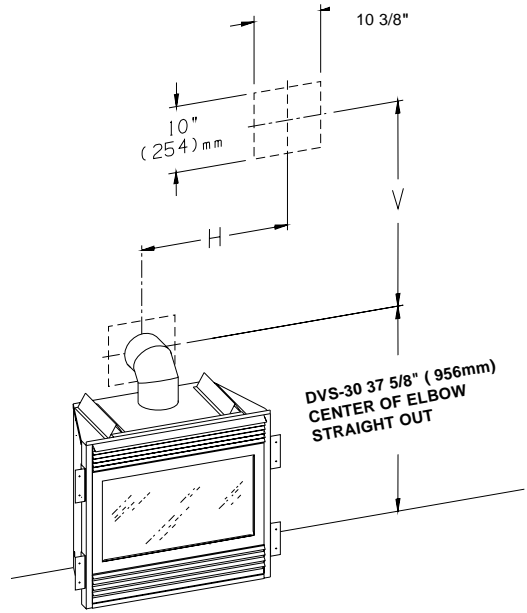

SEE CHART FOR PERMISSIBLE "H" AND "V" DIMENSIONS

Figure 22

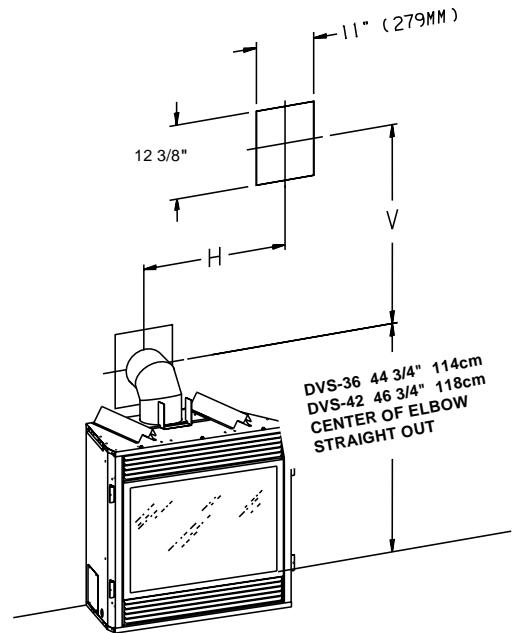

SEE CHART FOR PERMISSIBLE "H" AND "V" DIMENSIONS

Figure 23

Positioning the Fireplace

Determine the exact position of the appliance so the direct vent termination will be centered (if possible) between two (2) studs. This will avoid any extra framing. All vent kit pipes should be assembled on the unit after the unit is moved into the final position.

Cutting the Hole (Figures 22 and 23)

After the fireplace has been positioned in its permanent location, the hole through the exterior wall of the house can be cut. This hole must be 10" high x 10" wide for DVS-30 or 12 3/8" high x 10 3/8" wide for DVS-36/42 with its center line determined by the amount of vertical arise and horizontal run of the termination. (See Figures 22 and 23) When locating the hole it must be noted that the bottom of the cap must be 12" above the ground level, and top of the cap must be no less than 18" below a combustibile projection, and no closer than 9" to any wall running parallel to vent termination. (See Figure 24)

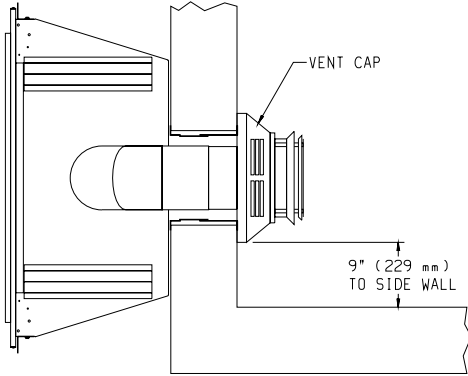

Figure 24

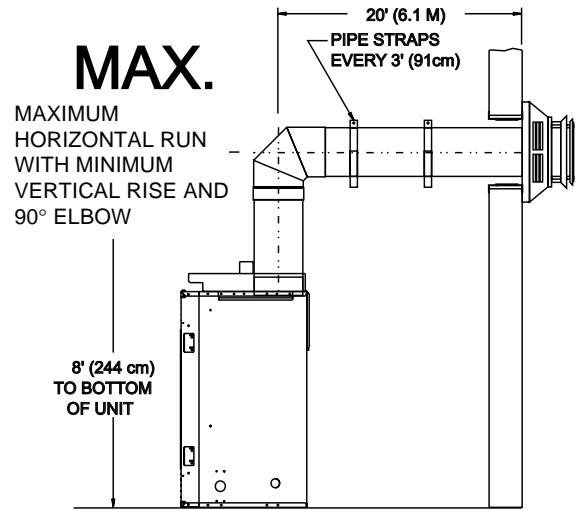
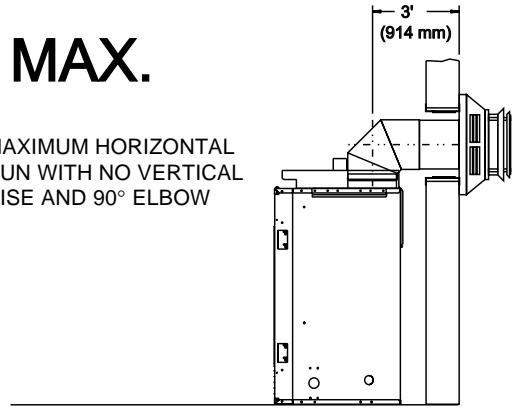

Figure 25

TERMINATION CLEARANCES

Termination clearance for buildings with combustible and noncombustible exteriors.

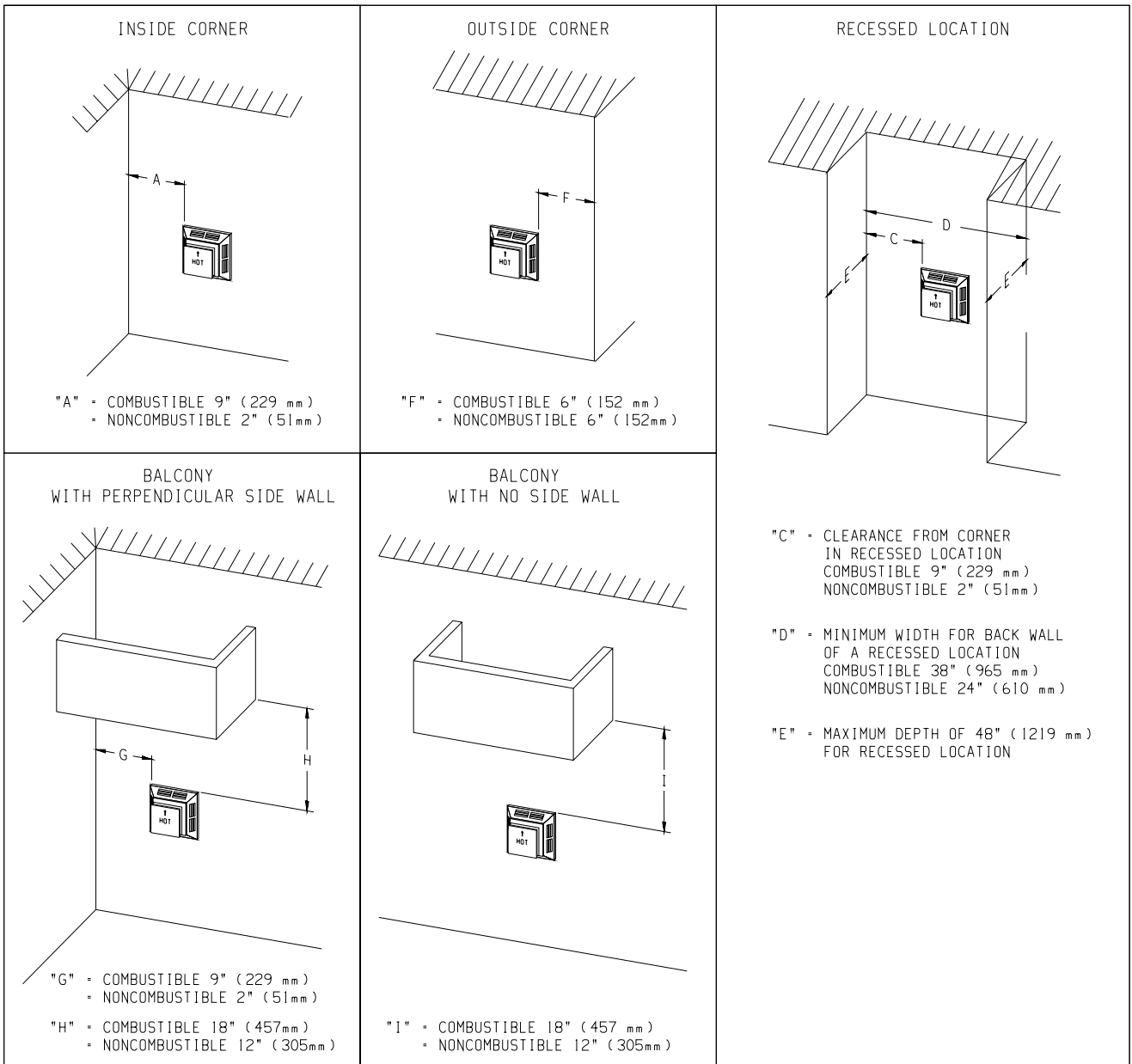

Figure 26

Vertical Sidewall Installations

Important! Minimum clearance between vent pipes and combustible materials is three (3") (76mm) on top, and (1") (25mm) on bottom and sides.

Important! When vent termination exits through foundation less than 20" below siding outcrop, the vent pipe must flush up with the siding. SD-985 for DVS-30 or SD-1284 for DVS-36/42 termination cap must be used.

Information on Various Venting Routes and Components

Important: It is always best to locate the fireplace in such a way that minimizes the number of offsets and horizontal vent length.

Since it is very important that the venting system maintain its balance between the combustion air intake and the flue gas exhaust, certain limitations as to vent configurations apply and must be strictly adhered to.

The graph showing the relationship between vertical and horizontal side wall venting will help to determine the various vent lengths allowable.

The horizontal vent run refers to the total length of vent pipe from the flue collar of the fireplace to the face of the outer wall.

The maximum horizontal vent run is 20 feet (457 cm) when the vertical vent rise is 8 feet (244 cm) (See Figure 25)

Venting terminals shall not be recessed into wall or siding.

VENT CLEARANCES

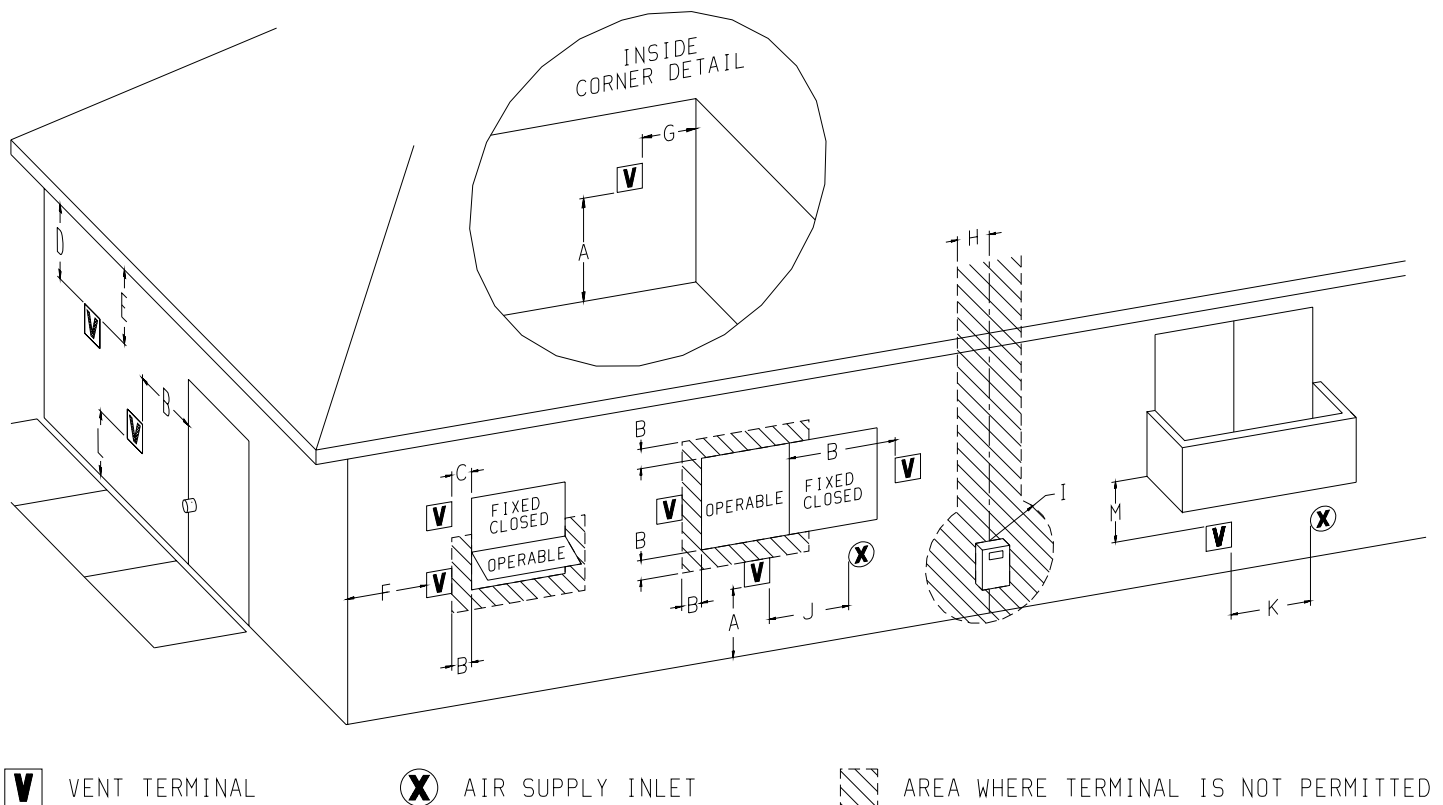

Figure 27

- A = *Clearance above grade, veranda, porch, deck or balcony [*12 inches (30cm) minimum]
- B = clearance to window or door that may be opened [*12 inches (30cm) minimum for appliances < 100,000 Btuh (30kW)
36 inches (90cm) minimum for appliances > 100,000 Btuh (30kW)]
- C = clearance to permanently closed window [minimum 12 inches (30cm) recommended to prevent condensation on window]
- D = vertical clearance to ventilated soffit located above the terminal within a horizontal distance of 18 inches (46 cm) from the top of the terminal
- E = clearance to unventilated soffit [12 inches (30cm) minimum]
- F = clearance to outside corner [12 inches (30cm) minimum]
- G = clearance to inside corner [9 inches (22.5cm) minimum]
- H = *not to be installed above a meter/regulator assembly within 3 feet (90cm) horizontally from the center-line of the regulator
- I = clearance to service regulator vent outlet [*6 feet (1.8m) minimum]

- J = clearance to non-mechanical air supply inlet to building or the combustion air inlet to any other appliance [*12 inches (30cm) minimum for appliances ≤ 100,000 Btuh (30 kW)
36 inches (90cm) minimum for appliances > 100,000 Btuh (30kW)]
- K = clearance to a mechanical air supply inlet [* 6 feet (1.8m) minimum]
- L = †clearance above paved sidewalk or a paved driveway located on public property [*7 feet (2.1m) minimum]
- M = clearance under veranda, porch, deck, or balcony [*12 inches (30cm) minimum ‡]
- † a vent shall not terminate directly above a sidewalk or paved driveway which is located between two single family dwellings and serves both dwellings*
- ‡ only permitted if veranda, porch, deck, or balcony, is fully open on a minimum of 2 sides beneath the floor*
- * as specified in CGA B149 Installations Codes or ANSI Z223.1. Note: Local Codes or Regulations may require different clearances.

VENT SYSTEM IDENTIFICATION

Installing Vent Components (Figure 28)

Begin the vent system installation by installing the first component, 90° elbow to the starting collars or straight pipe on the top of the appliance, then the straight pipe length and then horizontal or vertical termination kit.

NOTE: All outer connection joints must be sealed with aluminum tape or silicone sealant rated above 300°F/149°C. The inner flue joints do not require any sealant.

All vent system components lock into place by sliding the concentric pipe section with four (4) equally spaced interior beads onto the appliance collar or previously installed component end with four (4) equally spaced indented sections. When the internal beads of each starting outer pipe line up, rotate pipe section clockwise 90° (approximately 3 inches). The vent pipe is now locked together.

Continue adding components per the pre-planned vent system configuration. Be certain that each succeeding vent component is securely fitted and locked into the preceding component in the vent system.

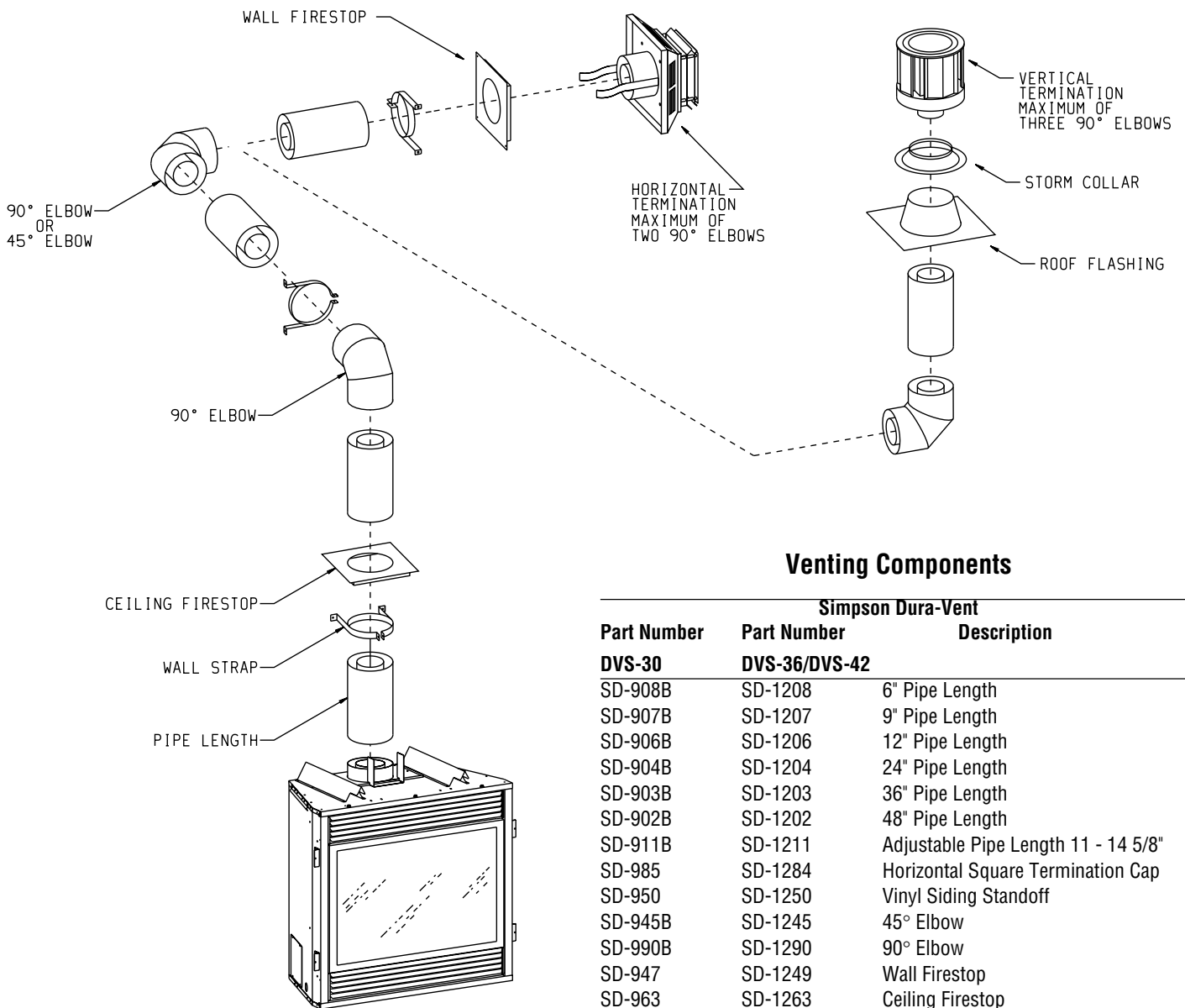

Figure 28

Venting Components

Simpson Dura-Vent		
Part Number	Part Number	Description
DVS-30		
SD-908B	SD-1208	6" Pipe Length
SD-907B	SD-1207	9" Pipe Length
SD-906B	SD-1206	12" Pipe Length
SD-904B	SD-1204	24" Pipe Length
SD-903B	SD-1203	36" Pipe Length
SD-902B	SD-1202	48" Pipe Length
SD-911B	SD-1211	Adjustable Pipe Length 11 - 14 5/8"
SD-985	SD-1284	Horizontal Square Termination Cap
SD-950	SD-1250	Vinyl Siding Standoff
SD-945B	SD-1245	45° Elbow
SD-990B	SD-1290	90° Elbow
SD-947	SD-1249	Wall Firestop
SD-963	SD-1263	Ceiling Firestop
SD-943	SD-1243	Roof Flashing - 0/12 to 6/12 Roof Pitch
SD-953	SD-1253	Storm Collar
SD-991	SD-1291	High Wind Vertical Top
SD-981	SD-1281	36" Snorkel
SD-982	SD-1282	14" Firestop Snorkel
SD-988	SD-1288	Wall Strap

DVS-30 FRAMING AND FINISHING

Installing Support Brackets (Figure 29)

A horizontal pipe support **MUST BE** used for each 3 feet of horizontal run. The pipe supports should be placed around 8 inch diameter pipe and nailed in place to framing members. There **MUST BE** a 3 inch clearance to combustibles above 6 5/8 inch diameter pipe and elbows and 1 inch clearance on both sides and bottom of 6 5/8 inch pipe to combustibles on all horizontal pipe sections and elbows.

Vertical runs of this vent systems must be supported every 4 feet above the appliance flue outlet by wall brackets attached to the 6 5/8 inch vent pipe and secured with nails or screws to structural framing members.

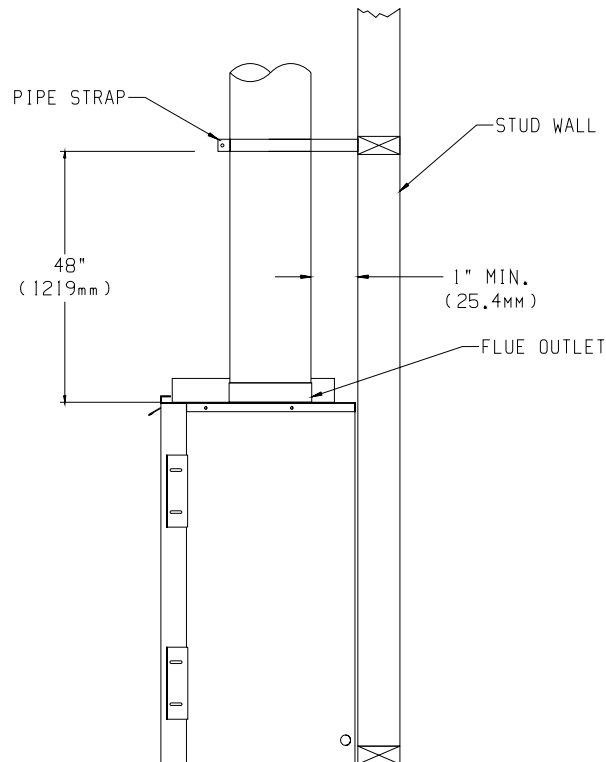

Figure 29

Installing Firestops (Figures 30, 31, 32 and 33)

Firestops are required for safety whenever the vent system passes through an interior wall, an exterior wall, or a ceiling. These firestops act as a firebreak heat shield and as a means to insure that minimum clearances are maintained to the vent system.

Horizontal runs in the vent system which pass through either interior or exterior walls, require the use of wall firestops on both sides of the wall through which the vent passes.

Position the firestops on both sides of the 10 inch x 10 inch hole, previously cut. Secure with nails or screws. The heat shields of the firestops **MUST BE** placed towards the top of the hole. Continue the vent run through the firestops. (Figure 30)

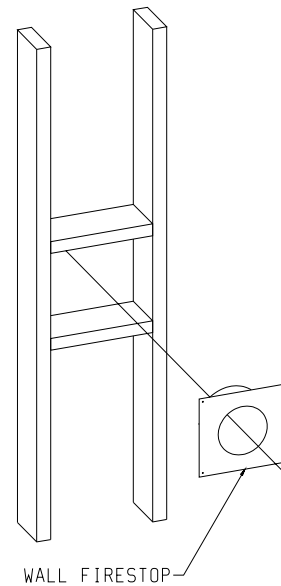

Figure 30

Vertical runs of this system which pass through ceilings require the use of **ONE (1)** ceiling firestop at the hole in each ceiling through which the vent passes.

Position a plumb bob directly over the center of the vertical vent component and mark the ceiling to establish the center point of the vent. Drill a hole or drive a nail through this center point and check the floor above for any obstructions such as wiring or plumbing runs. Reposition the appliance and vent system, if necessary, to accommodate ceiling joists and/or obstructions.

Cut a 10 inch x 10 inch hole through the ceiling, using the center point previously marked. Frame the hole with framing lumber the same size as the ceiling joists. (See Figure 31) If the area above the ceiling is **NOT** an attic, position and secure the ceiling firestop (SD-963) on the ceiling side of the previously cut and framed hole. (See Figure 32) If the area above the ceiling **IS** an attic, position and secure the firestop on top of the previously framed hole. (See Figure 33)

NOTE: Remove insulation from the framed area in the attic before installing the firestop and/or vent pipes.

DVS-30 FRAMING AND FINISHING (continued)

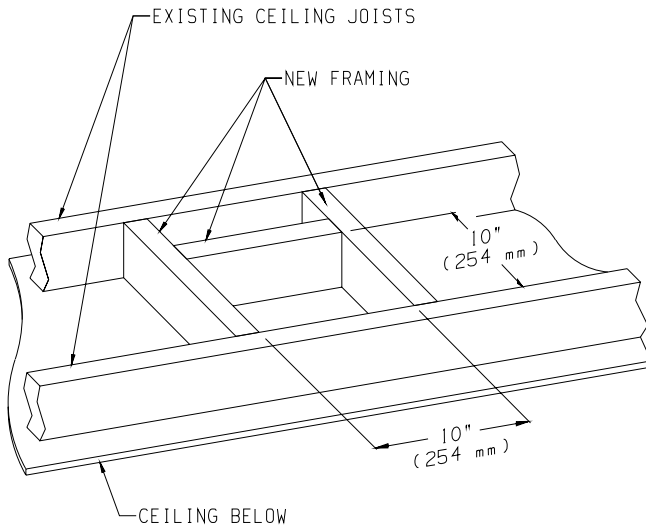

Figure 31

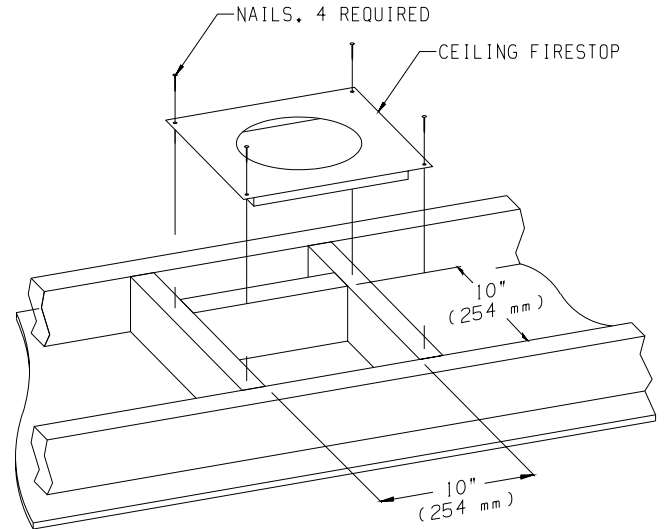

Figure 33

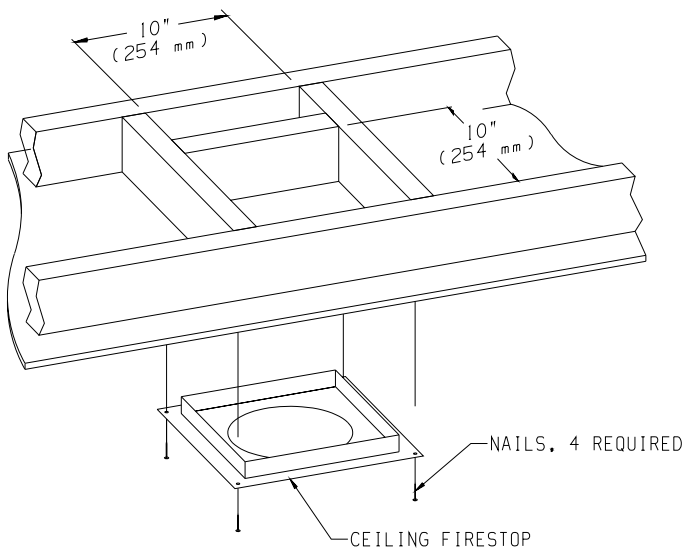

Figure 32

See "**Horizontal Termination (for all Models)**" Page 22 and "**Vertical Termination (for all Models)**" Page 23-24.

DVS-36 & DVS-42 FRAMING AND FINISHING

Installing Support Brackets (Figure 34)

A horizontal pipe support **MUST BE** used for each 3 feet of horizontal run. The pipe supports should be placed around 8 inch diameter pipe and nailed in place to framing members. There **MUST BE** a 3 inch clearance to combustibles above 8 inch diameter pipe and elbows and 1 inch clearance on both sides and bottom of 8 inch pipe to combustibles on all horizontal pipe sections and elbows.

Vertical runs of this vent systems must be supported every 4 feet above the appliance flue outlet by wall brackets attached to the 8 inch vent pipe and secured with nails or screws to structural framing members.

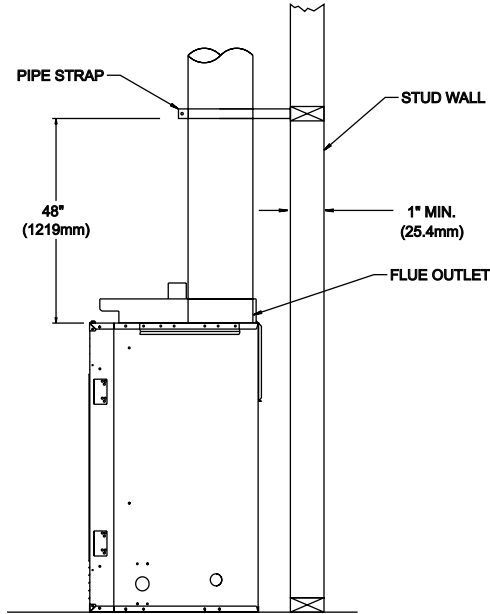

Figure 34

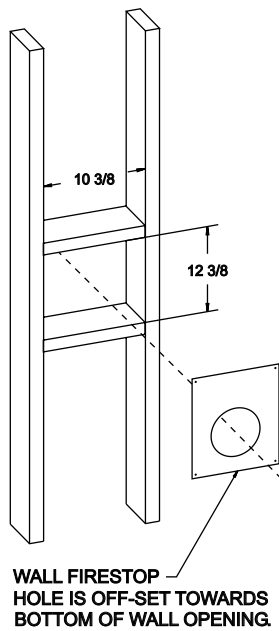

Figure 35

Installing Firestops (Figures 35, 36, 37 and 38)

Firestops are required for safety whenever the vent system passes through an interior wall, an exterior wall, or a ceiling. These firestops act as a firebreak heat shield and as a means to insure that minimum clearances are maintained to the vent system.

Cut a 10-3/8 inch x 12-3/8 inch hole in wall. Position firestop (SD-1249) on **interior** side of wall for 10-3/8 inch x 12-3/8 inch hole.

Attention: Wall firestop hole is off-set towards bottom of wall opening. Secure with nails or screws. Continue the vent run through the firestop. (See Figure 35)

Vertical runs of this system which pass through ceilings require the use of ONE (1) ceiling firestop at the hole in each ceiling through which the vent passes.

Position a plumb bob directly over the center of the vertical vent component and mark the ceiling to establish the center point of the vent. Drill a hole or drive a nail through this center point and check the floor above for any obstructions such as wiring or plumbing runs. Reposition the fireplace and vent system, if necessary, to accommodate ceiling joists and/or obstructions.

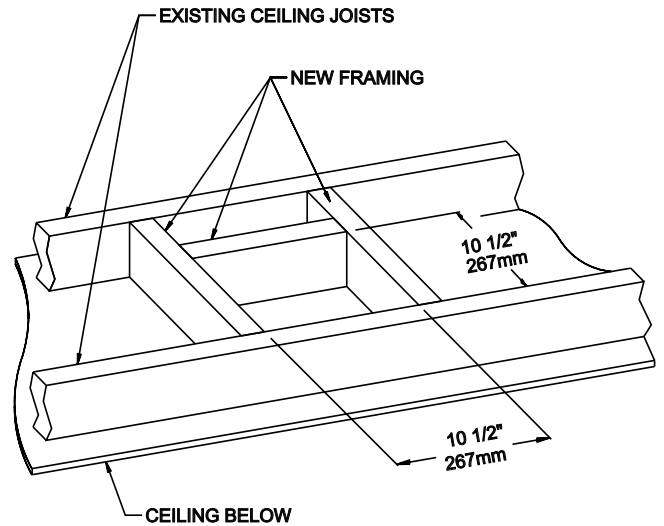

Figure 36

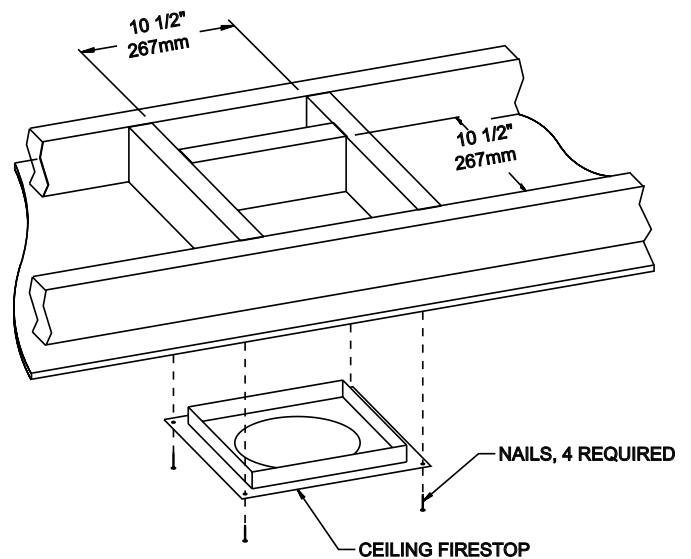

Figure 37

DVS-36 & DVS-42 FRAMING AND FINISHING (continued)

Cut a 10-1/2 inch x 10-1/2 inch hole through the ceiling, using the center point previously marked. Frame the hole with framing lumber the same size as the ceiling joists. (See Figure 36) If the area above the ceiling is NOT an attic, position and secure the ceiling firestop (SD-1263) on the ceiling side of the previously cut and framed hole. (See Figure 37) If the area above the ceiling is an attic, position and secure the firestop on top of the previously framed hole. (See Figure 38)

NOTE: Remove insulation from the framed area in the attic before installing the firestop and/or vent pipe.

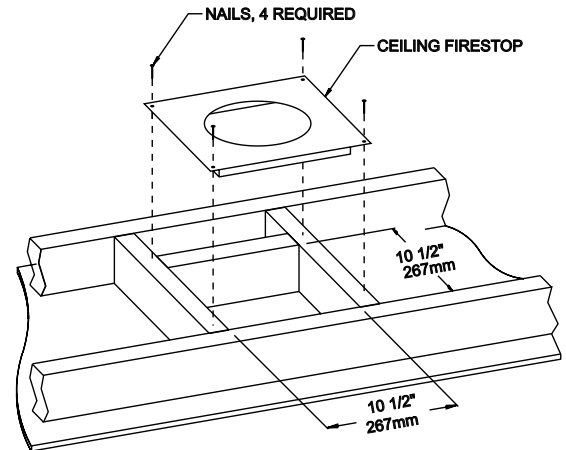

Figure 38

HORIZONTAL TERMINATION (For All Models)

NOTE: Termination cap should pass through the wall firestop from the exterior of the building. Adjust the termination cap to its final exterior position on the building.

WARNING: Termination cap must be positioned so that arrow is pointing up.

Attach the termination cap with the four wood screws provided. Before attachment of the termination, run a bead of silicone sealant rated above 250°F on its outside edge too, so as to make a seal to the exterior wall.

NOTE: Wood screws can and should be replaced with appropriate fasteners for use on stucco, brick, concrete or other types of siding.

CAUTION: If exterior walls are finished with vinyl siding, it is necessary to install the vinyl siding standoff SD-950 for DVS-30 or SD-1250 for DVS-36/42.

Vinyl siding standoff SD-950 for DVS-30 or SD-1250 for DVS-36/42 will be installed between the vent termination and the exterior wall. (See Figure 39) This horizontal vent termination bolts onto the flat portion of the vinyl siding standoff, so an air space will exist between the wall and the termination cap.

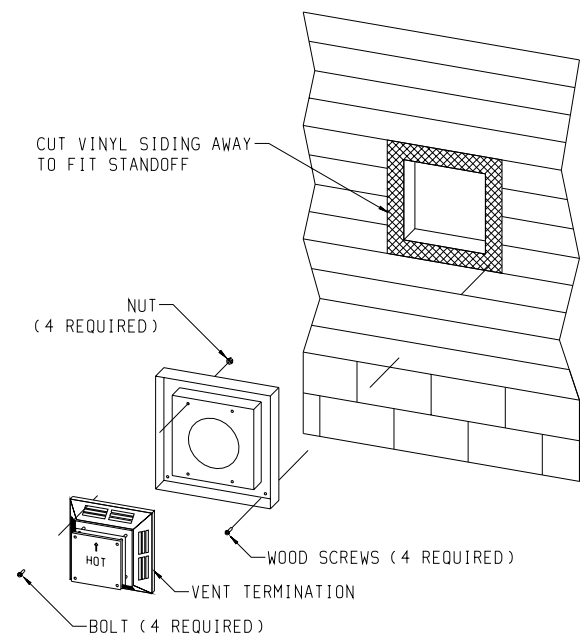

Figure 39

VERTICAL TERMINATION (For All Models)

Locate and mark the center point of the venting pipe. Using a nail on the underside of the roof and drive this nail through this center point. Make the outline of the roof hole around this center point.

NOTE: Size of the roof hole dimensions depend on the pitch of the roof. There must be a 1 inch clearance (25mm) to the vertical pipe sections. This clearance is to all combustible material.

Cover the opening of the vent pipe and cut and frame the roof hole. Use framing lumber the same size as the roof rafters and install the frame securely. Flashing anchored to frame must withstand high winds. The storm collar is placed over this joint to make a water-tight seal. Non-hardening sealant should be used to completely seal this flashing installation.

Determining Minimum Vent Height Above the Roof.

WARNING: Major U.S. building codes specify minimum chimney and/or vent height above the roof top. These minimum heights are necessary in the interest of safety. These specifications are summarized in Figure 40.

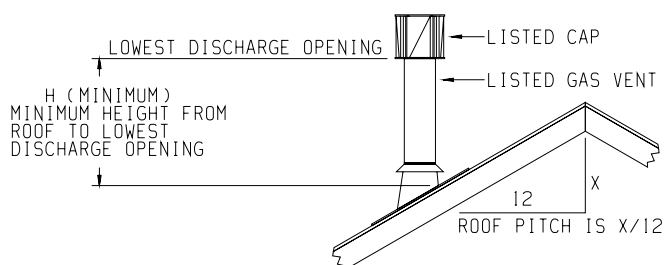

ROOF PITCH	H (MINIMUM)	
	FEET	METER
FLAT TO 6/12	1.0	0.30
6/12 TO 7/12	1.25	0.38
OVER 7/12 TO 8/12	1.5	0.46
OVER 8/12 TO 9/12	2.0	0.61
OVER 9/12 TO 10/12	2.5	0.76
OVER 10/12 TO 11/12	3.25	0.99
OVER 11/12 TO 12/12	4.0	1.22
OVER 12/12 TO 14/12	5.0	1.52
OVER 14/12 TO 16/12	6.0	1.83
OVER 16/12 TO 18/12	7.0	2.13
OVER 18/12 TO 20/12	7.5	2.27
OVER 20/12 TO 21/12	8.0	2.44

Figure 40

Note that for steep roof pitches, the vent height must be increased. In high wind conditions, nearby trees, adjoining roof lines, steep pitched roofs, and other similar factors can result in poor draft, or down-drafting. In these cases, increasing the vent height may solve this problem.

General Maintenance

Conduct an inspection of the venting system semi-annually. Recommended areas to inspect are as follows:

1. Check areas of the venting system which are exposed to the elements for corrosion. These will appear as rust spots or streaks and, in extreme cases, holes. These components should immediately be replaced.
2. Remove the cap and shine a flashlight down the vent. Remove any bird nests or other foreign material.
3. Check for evidence of excessive condensate, such as water

droplets forming in the inner liner and subsequently dripping out at joints. Continue condensate can cause corrosion of caps, pipe and fittings. It may be caused by having excessive lateral runs, too many elbows and exterior portions of the system being exposed to cold weather.

4. Inspect joints to verify that no pipe sections or fittings have been disturbed and, consequently, loosened. Also, check mechanical supports, such as wall straps or plumbers' tape for rigidity.

Venting terminal shall not be recessed into a wall or siding.

A removable panel or other means must be provided in the enclosure for visual inspection of the flue connection.

NOTE: This also pertains to vertical vent systems installed on the outside of the building.

Slide the vertical top SD-991 for DVS-30 or SD-1291 for DVS-36/42 over the ends of the vent pipe and secure. (See Figure 41)

Installing the Vent System in a Chase

A chase is a vertical box like structure built to enclose the gas appliance and/or its vent system. Vertical vent runs on the outside of a building may be, but are not required to be installed inside a chase.

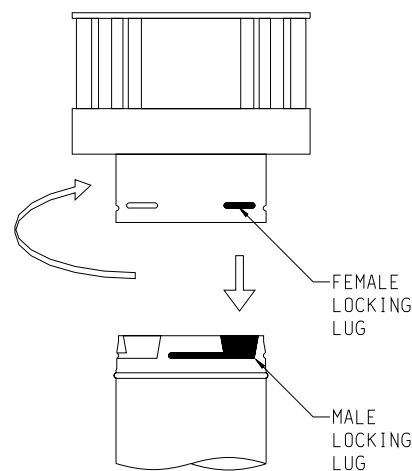

SLIDE FEMALE LOCKING LUG DOWN INTO MALE LOCKING LUG AND TWIST CLOCKWISE TO LOCK

Figure 41

CAUTION: Treatment of firestop spacers and construction of the chase may vary with the type of building. These instructions are not substitutes for the requirements of local building codes. Therefore, your local building codes must be checked to determine the requirements for these steps.

NOTE: When installing this vent system in a chase, it is always good building practice to insulate the chase as you would the outside walls of your home. This is especially important for cold climate installations. Upon completion of building your chase framing, install the vent system by following the instructions in this manual. Remember to build the chase large enough so that minimum clearance of combustible materials (including insulation) to the vent system are maintained.

VERTICAL TERMINATION (For All Models) (continued)

Reassembly and Resealing Vent Pipe System

Attach adapter pipe to vent cover in either the vertical or horizontal position, replace horizontal and vertical pipe lengths, elbows and horizontal or vertical termination kit.

All vent system components lock into place by sliding the concentric pipe section with four (4) equally spaced interior beads onto the appliance collar or previously installed component end with four (4) equally spaced indented sections. When the internal beads of each starting outer pipe line up, rotate pipe section clockwise 90° (approximately 3 inches). The vent pipe is now locked together.

Continue replacing components per the vent system configuration. Be certain that each succeeding vent component is securely fitted and locked into the preceding component in the vent system.

Reassembly and Resealing Gas Accumulation Relief System (Relief Doors) and Combustion Chamber

Whenever the relief door is pivoted open by a delayed ignition in the main burner, the relief door gaskets and combustion chamber must be examined by a qualified service person for damage. All damaged gaskets on the relief door and combustion chamber must be replaced by a qualified service person. If damage occurs to the combustion chamber, it must be replaced by a qualified service person. Contact Empire Comfort Systems, Inc. for replacement parts.

Vertical Through the Roof Applications (Figure 42)

Your Gas Fireplace has been approved for:

- a) Vertical installations up to 25 feet in height.

- b) Two sets of 45 degree elbow offsets within these vertical installations. From 0 to a maximum of 8 ft. a vent pipe can be used between elbows.
- c) Wall straps must be used to support offset pipe every 4'.

This applications will require that you first determine the roof pitch and use the appropriate venting components.

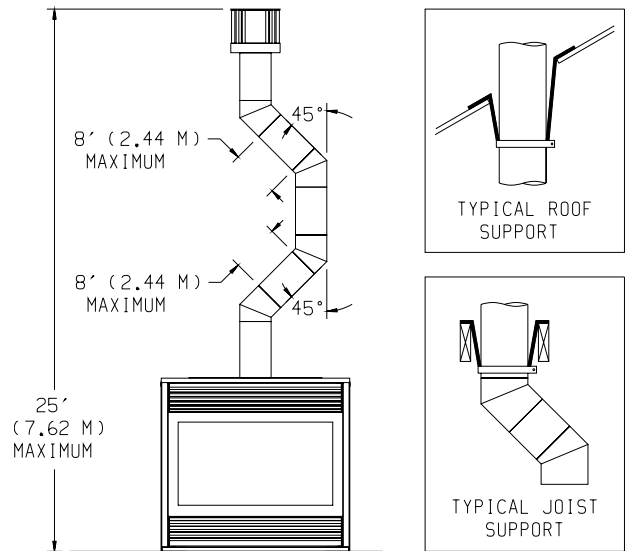

Figure 42

LOG PLACEMENT

Before you begin: This unit is supplied with a set of five ceramic fiber logs. Do not handle these logs with your bare hands! Always wear gloves to prevent skin irritation from ceramic fibers. After handling logs, wash your hands gently with soap and water to remove any traces of fibers.

Every burner is shipped with a shipping plate. This shipping plate must be removed before log placement.

The positioning of the logs is critical to the safe and clean operation of this fireplace. Sooting and other problems may result if the logs are not properly and firmly positioned in the fireplace.

Glass Removal

1. Push up and outward to remove top louver.
2. Lower door assembly.
3. Release two door latches at bottom of firebox.
4. Grasp bottom of glass frame, lift glass frame upward in order to release glass frame from lip on top of firebox.
5. Remove shipping plate from burner pan.
6. Place two (2) log grates onto two (2) left, front pins and two (2) right, front pins on burner pan. Secure grates with two (2) Tinnerman clips.

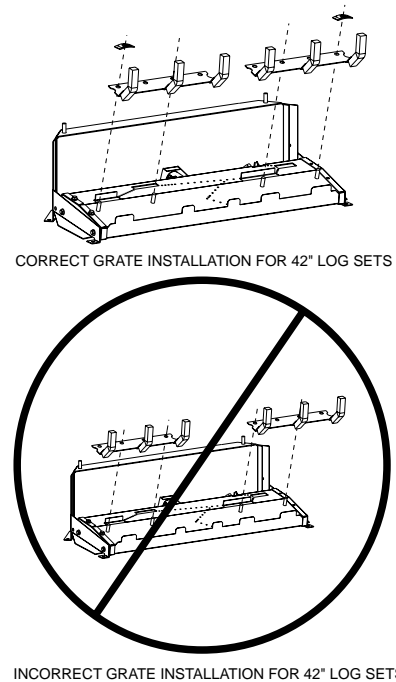

Figure 43

7. Place rear (#1) log onto right, rear pin on rear log support.
 8. Place middle (#2) log between rear log support and burner pan.
 9. Place left, front (#3) log onto two (2) left, front pins on burner pan.
 10. Place right, front (#4) log onto two (2) right, front pins on burner pan.
 11. Place branch (#5) log onto two (2) pins on middle (#2) log.
- Attention:** See placement of glowing embers and lava rock before proceeding to glass replacement.

Glass Replacement

12. Align and place top of glass frame over lip on top of firebox.
13. Grasp bottom of glass frame, push inward and place glass frame onto firebox.
14. Attach two door latches onto bottom of glass frame.
15. Align and insert (4) mounting tabs on top louver with (4) slots casing top. Push downward to lock the top louver into position.

Refer to Figures 43, 44 and 45 for the following warning.

Warning: Failure to position the parts in accordance with this diagram or failure to use only parts specifically approved with this appliance may result in property damage or personal injury.

Attention: Do not use Figure 44 or Figure 45 to order logs. Refer to Pages 41, 42 and 43 Parts List and Page 44, Parts View to order logs for your appropriate model number.

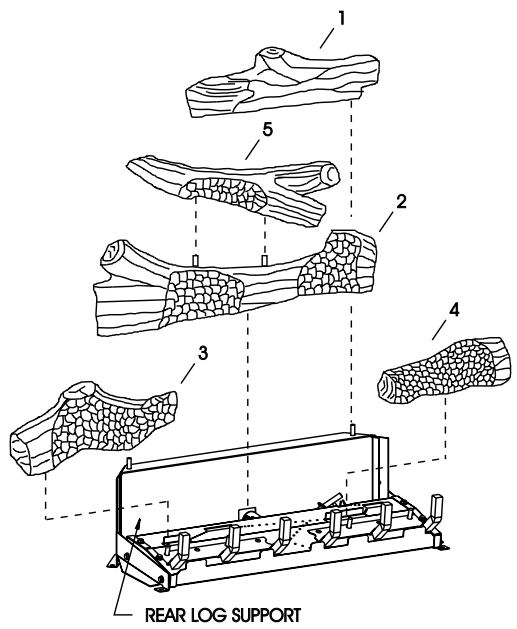

DVS-36 and DVS-42 Log Placement

Figure 45

Placement of Glowing Embers (Rock Wool) (Figure 46)

Provided with the log set is a small bag of glowing embers (rock wool) to be placed between logs on the flat metal surface of the burner.

**TOP VIEW OF LOG SET
REAR LOG**

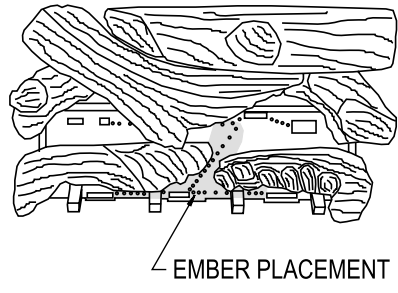

DVS-30 Placement of glowing embers.

Figure 46

**TOP VIEW OF LOG SET
REAR LOG**

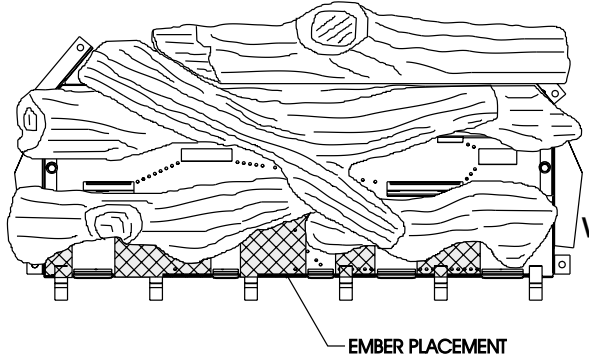

DVS-36 and DVS-42 Placement of glowing embers.

Figure 47

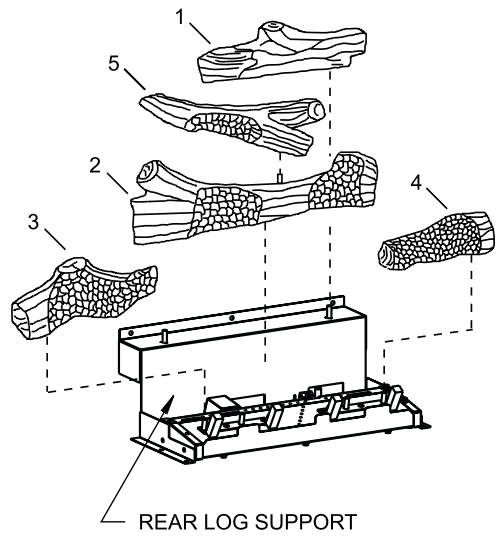

DVS-30 Log Placement

Figure 44

Placement of the glowing embers (rock wool) is very individual and light coverage of the areas indicated will provide your best effects. We recommend separation of the rock wool by hand and make your coverage as light and fluffy as possible.

Place just enough rock wool on the burner to obtain the glow and a gold yellow flame.

Do not place rock wool over large ports in rear portion of burner.

A thin layer of glowing embers (rock wool) should be placed under open space between the right and left middle logs.

Rock wool should **not** be placed in the area of the pilot assembly.

Placing Lava (Decorative) Rock in Front of Grate and Burner Pan on Fireplace Floor

Spread lava rocks on fireplace floor in front of grate. The rocks are for decorative effect and are not required for fireplace operation.

ATTENTION: DO NOT PLACE LAVA ROCKS ON LOGS, BRANCHES OR ROCK WOOL. THE LAVA ROCKS SHOULD ONLY BE PLACED ON THE FIREPLACE FLOOR.

FLAME APPEARANCE

Flames from the pilot (rear right back side of the pan burner) as well as the main flame should be visually checked as the log set is installed.

In normal operation at full rate after 10 to 15 minutes, the flame appearance should be sets of yellow flames.

NOTE: Flames will be random by design, flame height will go up and down.

Glowing embers (rock wool) can cover the pan burner in between the front and middle logs, but very little is necessary to cover this area. Excess rock wool material causes the yellow flame to become orange and stringy. Apply just enough to obtain slow glow and a bright yellow flame.

During manufacturing, fabricating and shipping, various components of this appliance are treated with certain oils, films or bonding agents. These chemicals are not harmful, but may produce annoying smoke and smells as they are burned off during the initial operation of the appliance, possibly causing headaches or eye or lung irritation. This is a normal and temporary occurrence.

The initial break-in operation should last 2-3 hours with the burner at the highest setting. Provide maximum ventilation by opening windows or doors to allow odors to dissipate. Any odors remaining after this initial break-in will be slight and will disappear with continued use.

STANDING PILOT OPERATING INSTRUCTIONS

The standing pilot (750 millivolt system) is a continuous burning pilot. The pilot remains ON even when the main burner is OFF.

750 Millivolt System (Figures 48 and 49)

When you ignite the pilot, the thermocouple produces millivolts (electrical current) which energizes the magnet in the gas valve. After 30 seconds to 1 minute time period you can release the gas control knob and the pilot will stay ON. Allow your pilot flame to operate an additional one (1) to two (2) minutes before you turn the gas control knob from the PILOT position to the ON position. This time period allows the millivolts (electrical current) to build-up to a sufficient level allowing the gas control to operate properly.

1. Follow the SAFETY and LIGHTING INSTRUCTIONS for standing pilot controls found in this manual and on labels found in control compartment behind the door assembly.

CAUTION: During the initial purging and subsequent lightings, never allow the gas valve control knob to remain depressed in the "pilot" position without pushing the red ignitor button at least once every second.

2. During the heating season, leave the control valve knob in the "ON" position. This will allow the pilot flame to remain lit. Turn the burner flame on or off with the fireplace ON/OFF rocker switch, wall switch, remote control kit or 750 millivolt wall thermostat.

NOTE: The gas control valve allows you to increase or decrease the height of the main burner flame. The control valve has a pressure regulator with a knob as shown in Figure 48. Rotate the knob clockwise to "HI" to increase the flame height and counterclockwise to "LO" to decrease the flame height.

3. When the heating season is over, turn the on/off switch to "OFF" and the control valve to "OFF". The system, including the pilot light, will be shut down.

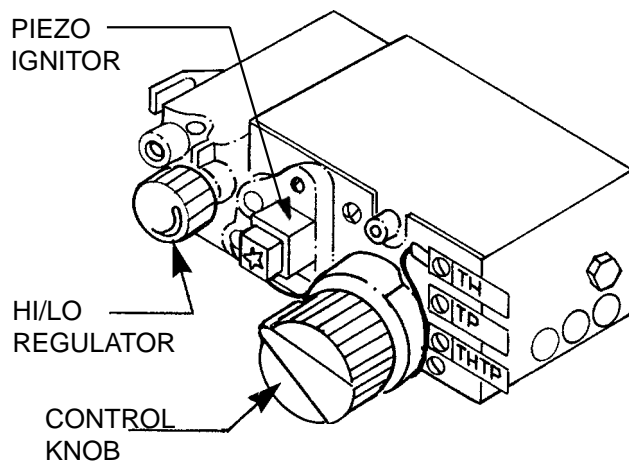

Figure 48

The OWNER should carefully read and follow these operating instructions at all times. Lower the door assembly to view the gas controls for the fireplace. Your model has a push button piezo ignitor, the fireplace has a STANDING PILOT IGNITION SYSTEM. Follow the Lighting Instructions applicable to your fireplace.

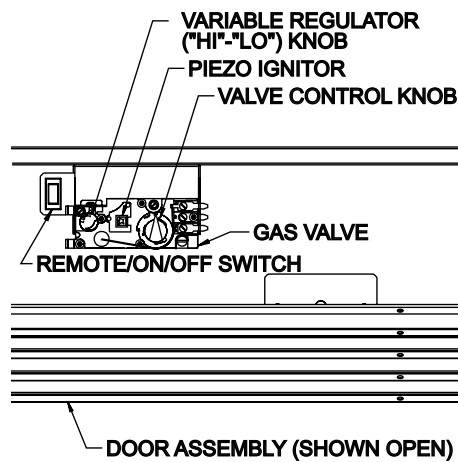

Figure 49

Initial Lighting

Upon completing the gas line or turning the gas valve on after it has been in the "OFF" position, a small amount of air will be in the lines. When first lighting the fireplace, it will take a few minutes for the lines to purge themselves of this air. Once the purging is complete, the fireplace will light and operate satisfactorily.

Subsequent lightings of the appliance will not require such purging if the gas valve is not turned to "OFF."

Pilot Flame (Figure 50)

The thermopile/thermocouple (standing pilot) tips should be covered with flame.

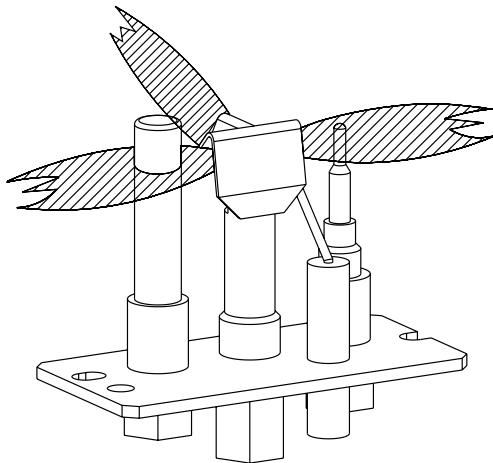

Figure 50

STANDING PILOT OPERATING INSTRUCTIONS ON/OFF/REMOTE Switch

DVS is equipped with an ON/OFF/REMOTE switch. A wire harness is attached to the ON/OFF/REMOTE switch. The red, black and green (wires) female push-ons attach to the ON/OFF/REMOTE switch. At the opposite end of the wire harness, the black and green (wires) female push-ons attach to the gas valve. An additional green wire and the red wire, which are stripped and bare, will attach to the 750 millivolt wall thermostat accessory, or, to one of the other accessories that can be purchased for use with your log set.

Operation of ON/OFF/REMOTE Switch with no Accessories

To ignite main burner, turn the control knob on the gas valve from the PILOT position to the ON position. Turn the ON/OFF/

REMOTE switch from the OFF position to the ON position. The additional green wire and red wire, which are stripped and bare are not used.

Operation of ON/OFF/REMOTE Switch with Accessories 750 Millivolt Wall Thermostat, GWSG-T

Connect the green and red, stripped and bare, wires on the ON/OFF/REMOTE switch wire harness to the wall thermostat. Turn the ON/OFF/REMOTE switch to the REMOTE position. Set the wall thermostat to the desired temperature.

It is important to use wire of a gauge proper for the length of the wire:

RECOMMENDED WIRE GAUGES

Maximum Length	Wire Gauge
1' to 10'	18
10' to 25'	16
25' to 35'	14

Wall Switch, FWS-1

Connect the green and red, stripped and bare, wires on the ON/OFF/REMOTE switch wire harness to the wall switch. Turn the ON/OFF/REMOTE switch to the REMOTE position. Pivot the rocker switch on the FWS-1 to the ON position.

Battery Operated Remote Control, FRBC-1 and FRBTC-1

Connect the green and red, stripped and bare, wires on the ON/OFF/REMOTE switch wire harness to the remote receiver that is a component in the FRBC-1 and FRBTC-1. Turn the ON/OFF/REMOTE switch to the REMOTE position. Follow instructions in the FRBC-1 and FRBTC-1 to complete installation.

Note: If batteries fail in FRBC-1 or FRBTC-1, and immediate heat is desired, turn the ON/OFF/REMOTE switch from the REMOTE position to the ON position.

Electric (120 volt) Operated Remote Control, FREC-1

Connect the green and red, stripped and bare, wires on the ON/OFF/REMOTE switch wire harness to the wires on remote receiver that is a component in the FREC-1. Turn the ON/OFF/REMOTE switch to the REMOTE position. Follow instructions in the FREC-1 to complete installation.

Note: If electric (120 volt) fails in FREC-1, and immediate heat is desired, turn the ON/OFF/REMOTE switch from the REMOTE position to the ON position.

Wiring of ON/OFF/REMOTE Switch with 750 Millivolt Wall Thermostat Accessory and Another Accessory

Connect the green and red, stripped and bare, wires on the ON/OFF/REMOTE switch wire harness to the 750 millivolt wall thermostat AND to the remote receiver that is a component in the FRBC-1, FREC-1 OR to the FWS-1, wall switch.

1. Connect (1) wire from the 750 millivolt wall thermostat and (1) wire from appropriate accessory to the GREEN, stripped and bare wire from the ON/OFF/REMOTE wire harness.
2. Connect (1) wire from the 750 millivolt wall thermostat and (1) wire from appropriate accessory to the RED, stripped and bare wire from the ON/OFF/REMOTE wire harness.

Note: When the appliance is in the MANUAL mode and the batteries fail in the FRBC-1 or if the electric (120 volt) fails in the FREC-1, and immediate heat is desired, turn the ON/OFF/REMOTE switch from the REMOTE position to the ON position.

STANDING PILOT OPERATING INSTRUCTIONS (continued)

Manual Operation

1. Turn ON/OFF/REMOTE switch to REMOTE position.
2. Turn wall thermostat OFF.
3. Turn accessory, FRBC-1, FRBTC-1, FREC-1 or FWS-1, ON.
Appliance is now in the manual mode. You must turn the appliance ON or OFF with appropriate accessory.

Wall Thermostat Operation

1. Turn the ON/OFF/REMOTE switch to REMOTE position.
2. Turn accessory, FRBC-1, FRBTC-1, FREC-1 or FWS-1, OFF.
3. Turn wall thermostat ON and set appropriate temperature.
Wall thermostat will cycle the appliance ON and OFF.

Installation of Remote Receiver

Place remote receiver on the floor of fireplace behind the louver as far forward as possible.

Attention: The velcro loop and hook are not necessary in this installation but can be used to secure remote receiver.

Refer to remote control installation and operating instructions for more details on remote control.

Millivolt Control

The valve regulator controls the burner pressure which should be checked at the pressure test point. Turn captured screw counter clockwise 2 or 3 turns and then place tubing to pressure gauge over test point (Use test point "A" closest to control knob). After taking pressure reading, be sure and turn captured screw clockwise firmly to re-seal. Do not over torque. Check for gas leaks.

Millivolt thermopile is self powered gas valve and does not require 110 volts.

Check System Operation

Millivolt system and all individual components may be checked with a millivolt meter 0-1000 MV range.

STANDING PILOT WIRING DIAGRAM

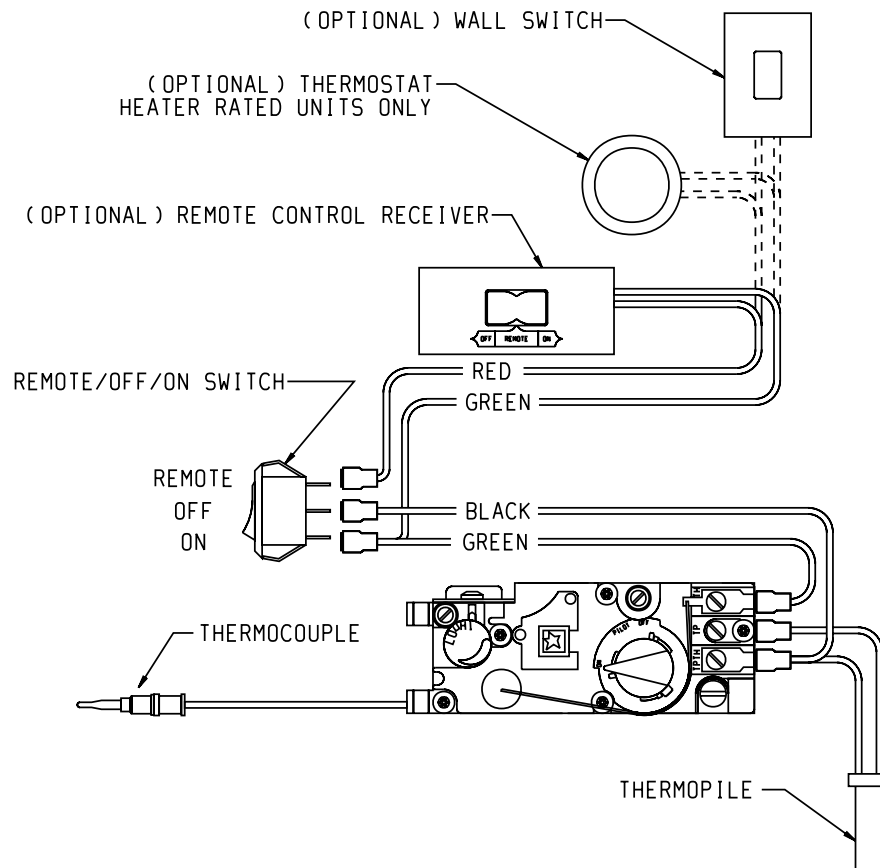

Figure 51

STANDING PILOT LIGHTING INSTRUCTIONS

FOR YOUR SAFETY READ BEFORE LIGHTING

WARNING: If you do not follow these instructions exactly, a fire or explosion may result causing property damage, personal injury or loss of life.

- A. This fireplace has a pilot which must be lighted by hand. When lighting the pilot, follow these instructions exactly.
- B. **BEFORE LIGHTING** smell all around the appliance area for gas. Be sure to smell next to the floor because some gas is heavier than air and will settle on the floor.
- WHAT TO DO IF YOU SMELL GAS**
- Do not try to light any appliance.
 - Do not touch any electrical switch; do not use any phone in your building.
 - Immediately call your gas supplier from a neighbor's phone. Follow the gas supplier's instructions.
- If you cannot reach your gas supplier, call the fire department.
- C. Use only your hand to push in or turn the gas control knob. Never use tools. If the knob will not push in or turn by hand, don't try to repair it; call a qualified service technician. Force or attempted repair may result in a fire or explosion.
- D. Do not use this appliance if any part has been under water. Immediately call a qualified service technician to inspect the appliance and to replace any part of the control system and any gas control which has been under water.

LIGHTING INSTRUCTIONS

1. **STOP!** Read the safety information above.
2. Set **REMOTE/OFF/ON** switch to **OFF**.
3. Turn off all electric power to the fireplace (if applicable).
4. Lower louver front assembly.
5. Push in gas control knob slightly and turn clockwise  to "**OFF**."

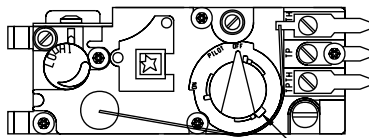



GAS CONTROL KNOB SHOWN IN "OFF" POSITION.

NOTE: Knob cannot be turned from "**PILOT**" to "**OFF**" unless knob is pushed in slightly. Do not force.

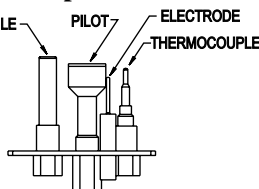
6. Wait ten (10) minutes to clear out any gas. Then smell for gas, including near the floor. If you then smell gas, **STOP!** Follow "**B**" in the safety information above. If you do not smell gas, go to the next step.
7. Find pilot — Follow metal tube from gas control. The pilot is behind the second log on the left side.



8. Turn gas control knob counterclockwise  to "**PILOT**."
9. Push in control knob all the way and hold in. Immediately light the pilot with the Piezo Pilot Ignitor or use a match. Continue to hold the control knob in the for about one (1) minute after the pilot is lit. Release knob, and it will pop back up. Pilot should remain lit. If it goes out, repeat steps 5 through 9.
 - If the control knob does not pop up when released, **STOP** and **IMMEDIATELY** call a qualified service technician or gas supplier.
 - If the pilot will not stay lit after several tries, turn the gas control knob to "**OFF**" and call your service technician or gas supplier.
10. Turn gas control knob counterclockwise  to the "**ON**."
11. Close louver front assembly.
12. Turn on all electric power to the appliance (if applicable).
13. Set **ON/OFF/REMOTE** switch to desired setting.

TO TURN OFF GAS TO FIREPLACE

1. Set **REMOTE/OFF/ON** switch to **OFF**.
2. Turn off all electric power to the fireplace if service is to be performed (if applicable).
3. Lower louver front assembly.
4. Push in gas control knob slightly and turn clockwise  to "**OFF**." Do not force.
5. Close louver front assembly.

STANDING PILOT TROUBLESHOOTING

With proper installation and maintenance, your new Gas Direct Vent Fireplace should provide years of trouble-free service. If you do experience a problem, refer to the Trouble Shooting Guide below. This guide will assist a qualified service person in the diagnosis of problems and the corrective action to be taken.

1. Spark ignitor will not light pilot after repeated triggering of piezo ignitor button.

- a. Defective ignitor (no spark electrode)
 - Check for spark at electrode and pilot; if no spark and electrode wire is properly connected, replace ignitor.
- b. No gas or low gas pressure.
 - Check remote shut off valves from fireplace. Usually there is a valve near the main. There can be more than one (1) valve between the fireplace and main.
 - Low pressure can be caused by a variety of situations such as a bent line, too narrow diameter of pipe, or low line pressure. Consult with plumber or gas supplier.
- c. No LP in tank.
 - Check LP (propane) tank. Refill tank.

2. Pilot will not stay lit after carefully following lighting instructions.

- a. Defective thermocouple.
 - Check that pilot flame impinges on thermocouple. Clean and/or adjust pilot for maximum flame impingement.
 - Ensure the thermocouple connection at the gas valve is fully inserted and tight (hand tight plus 1/4 turn). Faulty thermocouple if reading is below specified minimum of 15 millivolts.
 - Disconnect the thermocouple from the valve, place one millivolt meter lead wire on the end of the thermocouple and the other millivolt meter lead wire on the thermocouple copper wire. Start the pilot and hold the valve knob in. If the millivolt reading is less than 15 millivolt, replace the thermocouple.
- b. Defective valve.
 - If thermocouple is producing more than 15 millivolts, replace faulty valve.

3. Pilot burning, no gas to burner, valve knob "ON", on/off switch "ON."

- a. "On/Off" switch, wall switch, remote control or wires defective.
 - Check "on/off" switch and wires for proper connections. Place jumper wires across terminal at switch - if burner comes on, replace defective switch. If OK, place jumper wires across switch wires at gas valve-if burner comes on, wires are faulty or connections are bad.
- b. Thermopile may not be generating sufficient millivolts.
 - If the pilot flame is not close enough physically to the thermopile, adjust the pilot flame.
 - Be sure the wire connections from the thermopile at the gas valve terminals are tight and the thermopile is fully inserted into the pilot bracket.
 - Check the thermopile with a millivolt meter. Take the reading at TH-TP & TP terminals of the gas valve. The meter should read 350 millivolts minimum, while holding the valve knob depressed in the PILOT position, with the pilot lit, and the ON/OFF switch in the OFF position. Replace the faulty thermopile if the reading is below the specified minimum.

—With the pilot in the ON position, disconnect the thermopile leads from the valve. Take a reading at the thermopile leads. The reading should be 350 millivolts minimum. Replace the thermopile if the reading is below the minimum.

- c. Defective valve.
 - Turn valve knob to "ON." Place ON/OFF switch to "ON." Check with millivolt meter at thermopile terminals. Millivolt meter should read greater than 200 millivolts. If the reading is okay and the main burner does not ignite, replace the gas valve.
- d. Plugged main burner orifice.
 - Check main burner orifice for blockage and remove.

4. Frequent pilot outage problem.

- a. Pilot flame may be too high or too low, or blowing (high), causing pilot safety to drop out.
 - Clean and adjust flame for maximum flame impingement on the thermocouple. Follow lighting instructions carefully.

5. The pilot and main burner extinguish while in operation.

- a. No LP (Propane) in tank.
 - Check LP (Propane) tank. Refill fuel tank.
- b. Inner vent pipe leaking exhaust gases back into system
 - Check for leaks.
- c. Glass too loose, gasket leaks in corners after usage.
 - Be certain glass assembly is installed correctly and tighten screws.
- d. Horizontal vent improperly pitched.
 - The horizontal vent cap should slope down only enough to prevent any water from entering the unit. The maximum downwards slope is 1/4 inch.
- e. Bad thermopile or thermocouple.
 - Replace if necessary.
- f. Improper vent cap installation.
 - Check for proper installation and freedom from debris or blockage.

6. Glass soots.

- a. Flame impingement on logs.
 - Contact Empire Comfort Systems, Inc.
- b. Debris around throat of main burner.
 - Inspect the opening at the base of the main burner. It is imperative that **NO** material be placed in this opening.

7. Flame burns blue and lifts off main burner.



- a. Insufficient oxygen being supplied.
 - Check to make sure vent cap is installed properly and free of debris. Make sure that vent system joints are tight and have no leaks.
 - Check to make sure that no material has been placed at the main burner base.
 - Be sure glass is tightened properly on unit, particularly on top corners.

DVS-36 & DVS-42 INTERMITTENT PILOT OPERATING INSTRUCTIONS

The intermittent pilot (120/24 volt system) is ON when the main burner is ON. When the main burner is OFF the intermittent pilot is OFF.

The pilot flame should envelop 3/8 to 1/2 inch (10 to 13mm) of the tip of the flame rod.

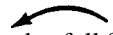
To adjust:

1. Remove the pilot adjustment cover screw.
2. Turn the inner adjustment screw clockwise  to decrease or counterclockwise  to increase pilot flame. Pilot adjustment is shipped at full flow rate. Turn the inner adjustment screw clockwise  if the inlet pressure is too high.
3. Replace the cover screw after the adjustment to prevent gas leakage.

Label all wires prior to disconnection when servicing controls. Wiring errors can cause improper and dangerous operation. Verify proper operation after servicing.

Provided on the intermittent pilot wiring harness are two (2) stripped and bare wires that are labeled THERMOSTAT. The wires will be used for attachment of 24 volt thermostat, optional FWS-1 wall switch or will attach into the receiver on an optional FRBC-1, FRBTC-1 or FREC-1 remote control.

Installation of Remote Receiver

Place remote receiver on the floor of fireplace behind the louver as far forward as possible.

Attention: The velcro loop and hook are not necessary in this installation but can be used to secure remote receiver.

DVS-36 & DVS-42 INTERMITTENT PILOT WIRING DIAGRAM

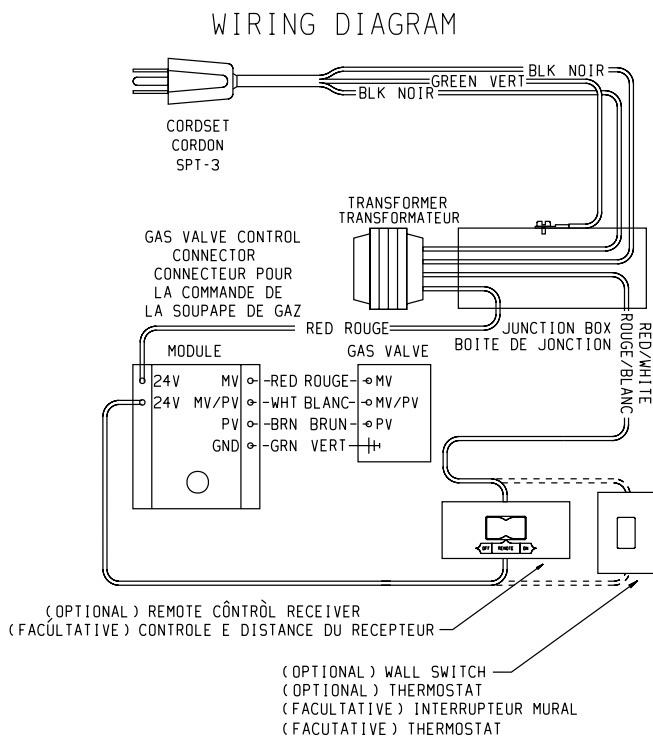

Figure 52

ELECTRICAL CONNECTION (Figure 53)

The DVS36/42IP with optional fan requires 120 VAC electrical hookup to the electrical box (installed).

The appliance, when installed, must be electrically grounded in accordance with local codes or, in the absence of local codes, with the *National Electrical Code, ANSI/NFPA 70*, if an external electrical source is utilized.

CAUTION: ALL WIRING SHOULD BE DONE BY A QUALIFIED ELECTRICIAN AND SHALL BE IN COMPLIANCE WITH ALL LOCAL, CITY AND STATE BUILDING CODES. BEFORE MAKING THE ELECTRICAL CONNECTION, MAKE SURE THAT MAIN POWER SUPPLY IS DISCONNECTED. THE APPLIANCE, WHEN INSTALLED, MUST BE ELECTRICALLY GROUNDED IN ACCORDANCE WITH LOCAL CODES OR, IN THE ABSENCE OF LOCAL CODES, WITH THE NATIONAL ELECTRICAL CODE ANSI/NFPA 70 (LATEST EDITION).

A factory installed electrical box is located on the lower right hand side of the fireplace. Wiring must be fed to the electrical box and attached to the receptacle that is provided. Remove the knockout in the installed junction box to accept wiring into the junction box. Install a UL listed cable clamp (not supplied) in the knockout hole. Leave approximately 6" of wire in the junction box for connection.

Attach black wire to one side of the receptacle and white wire to opposite side of receptacle. The ground wire should be attached to the green (neutral) screw.

Install the receptacle into the metal box with. Attach cover plate.

Plug cord set from transformer into receptacle.

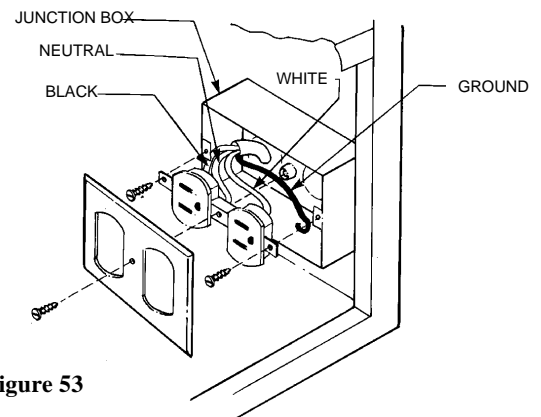

Figure 53



DVS-36 & DVS-42 INTERMITTENT PILOT LIGHTING INSTRUCTIONS

FOR YOUR SAFETY READ BEFORE LIGHTING

WARNING: If you do not follow these instructions exactly, a fire or explosion may result causing property damage, personal injury or loss of life.

- A. This appliance is equipped with an ignition device which automatically lights the pilot. Do not try to light the pilot by hand.
- B. **BEFORE LIGHTING** smell all around the appliance area for gas. Be sure to smell next to the floor because some gas is heavier than air and will settle on the floor.
- WHAT TO DO IF YOU SMELL GAS**
- Do not try to light any appliance.
 - Do not touch any electrical switch; do not use any phone in your building.
 - Immediately call your gas supplier from a neighbor's phone. Follow the gas supplier's instructions.
- If you cannot reach your gas supplier, call the fire department.
- C. Use only your hand to push in or turn the gas control knob. Never use tools. If the knob will not push in or turn by hand, don't try to repair it; call a qualified service technician. Force or attempted repair may result in a fire or explosion.
- D. Do not use this appliance if any part has been under water. Immediately call a qualified service technician to inspect the appliance and to replace any part of the control system and any gas control which has been under water.

LIGHTING INSTRUCTIONS

1. **STOP!** Read the safety information above.
2. Set the thermostat to lowest setting.
3. Turn off all electric power to the appliance.
4. This appliance is equipped with an ignition device which automatically lights the pilot. Do not try to light the pilot by hand.
5. Lower louver front assembly.
6. Turn gas control knob clockwise  to "OFF."
7. Wait ten (10) minutes to clear out any gas. Then smell for gas, including near the floor. If you smell gas, **STOP!** Follow "B" in the safety information above. If you don't smell gas, go to the next step.
8. Turn gas control knob counterclockwise  to "ON".
9. Close louver front assembly.
10. Turn on all electric power to the appliance.
11. Set thermostat to desired setting.
12. If the appliance will not operate, follow the instructions "TO TURN OFF GAS TO APPLIANCE" and call your service technician or gas supplier.

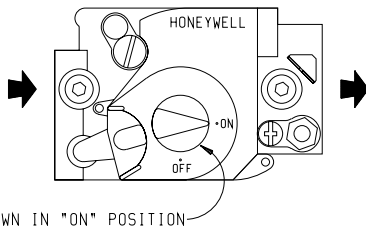

GAS CONTROL KNOB SHOWN IN "ON" POSITION

TO TURN OFF GAS TO APPLIANCE

1. Turn off all electric power to the appliance if service is to be performed.
2. Lower louver front assembly.
3. Push in gas control knob slightly and turn clockwise  to "OFF". Do not force.
4. Close louver front assembly.

DVS-36 & DVS-42 INTERMITTENT PILOT TROUBLESHOOTING

CALL SERVICEMAN

GENERAL: All furnaces have been fire-tested to check for proper operation. This includes, main burner flame, pilot flame, fan operation, fan control, limit control and automatic valve operation. If the furnace fails to function on initial installation, it is advisable to re-check the following:

1. 115 volts to the junction box.
2. Inlet gas pressure.
3. The 24 volt system.
4. Type of gas being used and that shown on the rating label.

The Service Department at Empire Comfort Systems, Inc. may be contacted to assist in servicing furnace.

Servicing the Pilot and Main Burners, Pilot Orifice, and Main Burner Orifices: Disconnect the gas supply at the inlet to the control valve. Then remove the burner door to which the above components are attached.

Servicing The Fan Motor: The upper front panel, the shroud surrounding the fan blade and fan blade must be removed. See "Oiling the Motor" paragraph on page 8.

S8600H INTERMITTENT IGNITION MODULE SPECIFICATIONS

Lockout timing is 90 seconds. Ignition timing is until pilot lights or lockout occurs.

Module shuts down and cuts power to gas control on flame failure. Gas control closes to provide 100 percent lockout on flame failure. Manual reset required.

ELECTRICAL RATINGS:

Voltage and frequency: 20.5 to 28.5V (24V nom.) 60 Hz.

Current rating: 0.2 A.

Valve contact ratings (at 24 Vac):

	Run	Inrush
Pilot	1.0 A	10.0 A
Main	1.0 A	10.0 A

SPARK GENERATOR OUTPUT: 13kV peak at 25 pf load.

THERMOSTAT ANTICIPATOR SETTING: 0.2 A plus pilot valve rating plus main valve rating.

THERMOSTAT COMPATIBILITY: Standard models compatible with all open-close switch type 24 Vac thermostats capable of supplying rated voltage and current to the module.

AMBIENT TEMPERATURE RATING: Minus 40 F to plus 175 F (minus 40 C to plus 79 C).

RELATIVE HUMIDITY RATING: 5 to 90 percent RH at 95 F.

FLAME FAILURE RESPONSE TIME: 0.8 seconds at 1.0 uA flame current.

FLAME CURRENT: 1 uA, min.

CHECKOUT

Check out the gas control system:

1. At initial installation of the appliance.
2. As part of regular maintenance procedures.
3. As the first step in troubleshooting.
4. Any time work is done on the system.

STEP 1: Perform Visual Inspection.

- A. With power off, make sure all wiring connections are clean and tight.
- B. Turn on power to appliance and ignition module.
- C. Open manual shutoff valves in the gas line to the appliance.
- D. Do gas leak test ahead of gas control if piping has been disturbed.

GAS LEAK TEST: Paint pipe joints with rich soap and water solution. Bubbles indicate gas leak. Tighten joints to stop leak.

STEP 2: Review Normal Operating Sequence and Module Specifications.

STEP 3: Reset the Module.

- A. Turn the thermostat to its lowest setting.
- B. Wait one minute.

As you do Steps 4 and 5, watch for points where operation deviates from normal. Refer to Troubleshooting Chart to correct problem.

STEP 4: Check Safety Lockout Operation.

- A. Turn gas supply off.
- B. Set thermostat above room temperature to call for heat.
- C. Watch for spark at pilot burner.
- D. Time length of spark operation. Maximum spark time is 90 seconds.
- E. Open manual gas cock and make sure no gas is flowing to pilot or main burner.
- F. Set thermostat below room temperature and wait one minute before continuing.

STEP 5: Check Normal Operation.

- A. Set thermostat above room temperature to call for heat.
- B. Make sure pilot lights smoothly when gas reaches the pilot burner.
- C. Make sure main burner lights smoothly without flashback. Make sure burner operates smoothly without floating or lifting.
- D. If gas line has been disturbed, complete gas leak test.

GAS LEAK TEST: Paint gas control gasket edges and all pipe connections downstream of gas control, including pilot tubing connections, with rich soap and water solution. Bubbles indicate gas leaks. Tighten joints and screws or replace component to stop gas leak.

- E. Turn thermostat below room temperature. Make sure main burner and pilot flames go out.

OPERATION

Module operation can be conveniently divided into two phases for S8600H. The phases are trial for ignition and main burner operation.

TRIAL FOR IGNITION

Pilot Ignition

Following call for heat (system start on S8600H), the module energizes the first main valve operator. The first main valve opens, which allows gas to flow to the pilot burner. At the same time, the electronic spark generator in the module produces a 13,000 volt spark pulse output (at 25 pf load). The voltage generates a spark at the igniter-sensor that lights the pilot.

DVS-36 & DVS-42 INTERMITTENT PILOT TROUBLESHOOTING

If the pilot does not light, or the pilot flame current is not at least 1.0 uA and steady, the module will not energize the second main valve and the main burner will not light.

Safety Lockout

S8600H provides 100 percent shutoff, or safety lockout. A timer starts timing the moment the trial for ignition starts. Ignition spark continues only until the timed trial for ignition period ends. Then the module goes into safety lockout. Lockout de-energizes the first main valve operator and closes the first main valve in the gas control, stopping pilot gas flow. The control system must be reset by setting the thermostat below room temperature for one minute or by turning off power to the module for one minute.

Main Burner Operation

When the pilot flame is established, a flame rectification circuit is completed between the sensor and burner ground. The flame sensing circuit in the module detects the flame current, shuts off the spark generator and energizes the second main valve operator. The second main valve opens and gas flows to the main burner, where it is ignited by the pilot burner. The flame current also holds the safety lockout timer in the reset (normal) operating condition.

When the call for heat ends, both main valve operators are de-energized, and both main valves in the gas control close.

CAUTION: Label all wires prior to disconnection when servicing controls. Wiring errors can cause improper and dangerous operation. Verify proper operation after servicing.

S8600H NORMAL OPERATING SEQUENCE

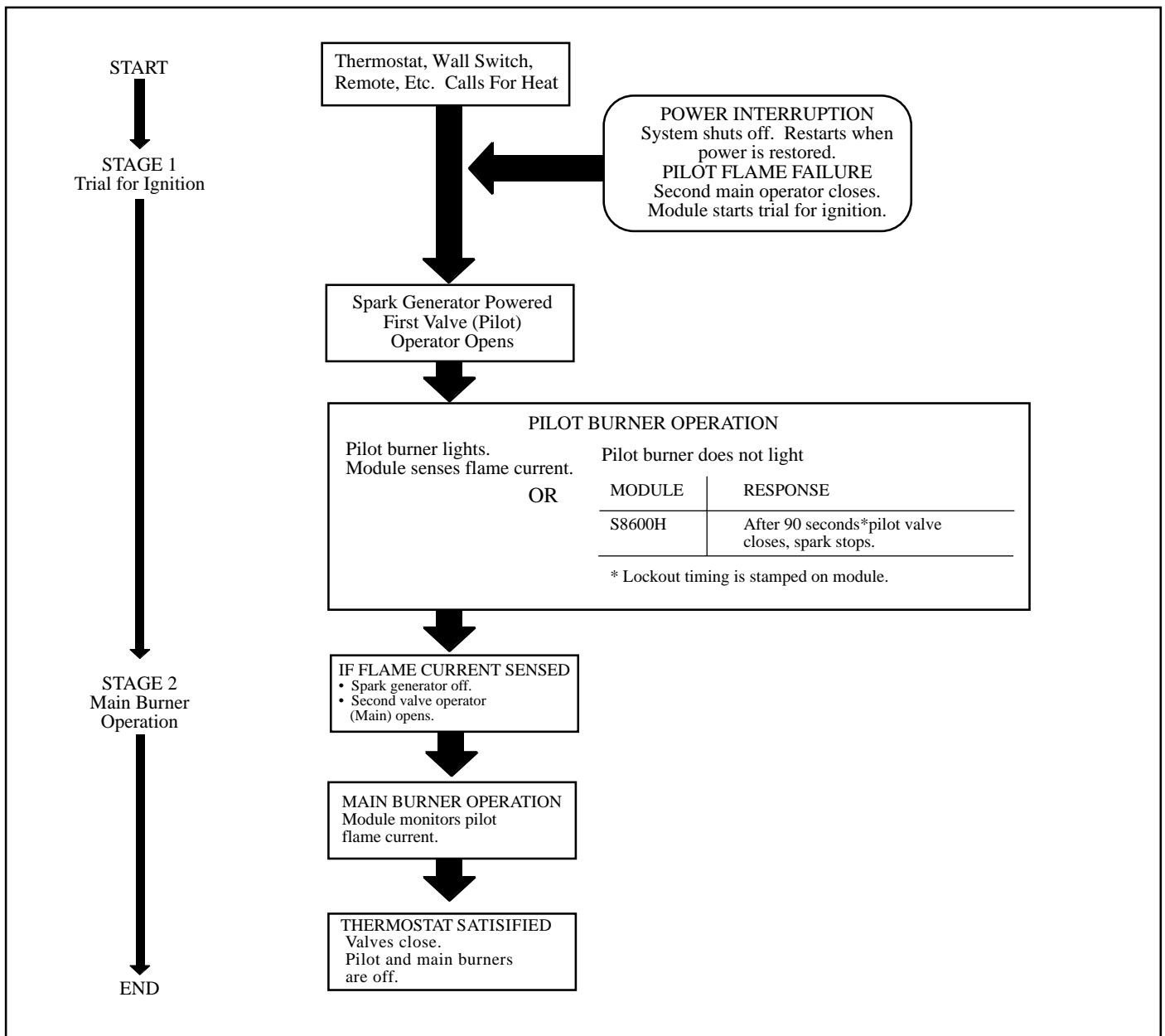

Important

1. The following service procedures are provided as a general guide.
2. Meter readings between gas control and ignition module must be taken within the trial for ignition period. Once the ignition module locks out, the system must be reset by setting the thermostat down for at least one minute before continuing.
3. If any component does not function properly, make sure it is correctly installed and wired before replacing it.
4. The ignition module cannot be repaired. If it malfunctions, it must be replaced.
5. Only trained, experienced service technicians should service intermittent pilot systems.

Perform the **CHECKOUT** steps on page 10 as the first step in troubleshooting. Then check **TROUBLESHOOTING GUIDE** to pinpoint the cause of the problem. If troubleshooting indicates an ignition problem, see **Ignition System Checks** below to isolate and correct the problem.

Following troubleshooting, perform the **CHECKOUT** procedure (page 10) again to be sure system is operating normally.

Ignition System Checks

Step 1: Check ignition cable.

Make sure:

- A. Ignition cable does not touch any metal surfaces.
- B. Ignition cable is no more than 36 inches long.
- C. Connections to the ignition module and to the igniter-sensor are clean and tight.
- D. Ignition cable provides good electrical continuity.

Step 2: Check ignition system grounding.

Nuisance shutdowns are often caused by a poor or erratic ground.

- A. A common ground, usually supplied by the pilot burner bracket, is required for the module and the pilot burner/igniter sensor.
 - Check for good metal-to-metal contact between the pilot burner bracket and the main burner.
 - Check the ground lead from GND (BURNER) terminal on the module to the pilot burner. Make sure connections are clean and tight. If the wire is damaged or deteriorated, replace it with No. 14-18 gauge, moisture-resistant, thermoplastic insulated wire with 105 C (221 F) minimum rating.
 - If flame rod or bracket are bent out of position, restore to correct position.
 - Replace pilot burner/igniter sensor if insulator is cracked.

Step 3: Check spark ignition circuit. *You will need a short jumper wire made from ignition cable or other heavily insulated wire.*

- A. Close the manual gas valve.
- B. Disconnect the ignition cable at the SPARK terminal on the module.

WARNING

When performing the following steps, do not touch stripped end of jumper or SPARK terminal. The ignition circuit generates 13,000 volts at 25 pf load and electrical shock can result.

- C. Energize the module and immediately touch one end of the jumper firmly to the GND terminal on the module. Move the free end of the jumper slowly toward the SPARK terminal until a spark is established.
- D. Pull the jumper slowly away from the terminal and note the length of the gap when sparking stops. Check table below.

ARC LENGTH	ACTION
No arc or arc less than 1/8 inch.	Check external fuse, if provided. Verify power at module input terminal. Replace module if fuse and power okay.
Arc 1/8 inch or longer.	Voltage output is okay.

Step 4: Check pilot flame current.

- A. Turn off furnace at thermostat.
- B. Disconnect main valve wire from the TH or MV terminal on the gas control.
- C. Disconnect ground wire from GND (BURNER) terminal at module.
- D. Connect a meter (dc microamp scale) in series with the ground lead.
 - Disconnect ground lead from GND terminal on ignition module.
 - Connect the black (negative) meter lead to the ignition module GND (BURNER) terminal.
 - Connect the red (positive) meter lead to the free end of the ground lead.
- E. Set thermostat to call for heat. The spark will light the pilot but the main burner will not light because the main valve actuator is disconnected.
- F. Read the meter. The flame sensor current must be steady and at least 1.0 uA.
- G. If the reading is less than the minimum or unsteady,
 - Make sure pilot flame envelopes 3/8 to 1/2 inch of the flame rod.
 - If necessary, adjust pilot flame by turning the pilot adjustment screw on the gas control clockwise to decrease or counterclockwise to increase pilot flame. Following adjustment, always replace pilot adjustment cover screw and tighten firmly to assure proper gas control operation.
 - Check for cracked ceramic insulator, which can cause short to ground, and replace igniter-sensor if necessary.
 - Make sure electrical connections are clean and tight. Replace damaged wire with moisture-resistant No. 18 wire rated for continuous duty up to 105 C (221 F).
- H. Remove meter and reconnect all wires. Return system to normal operation before leaving job.

S8600H TROUBLESHOOTING GUIDE

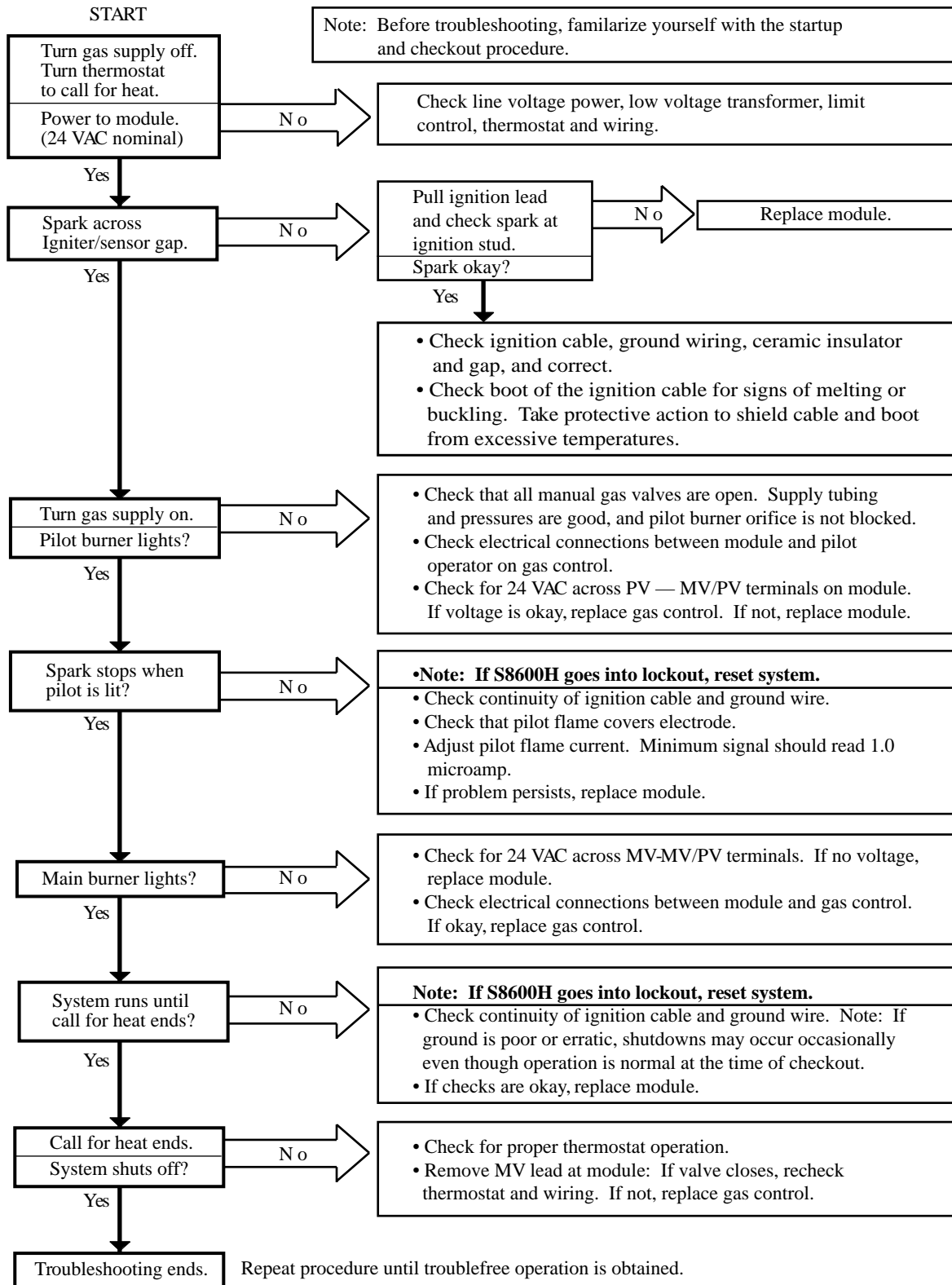

RF STANDING PILOT OPERATING INSTRUCTIONS

Features	Benefits
• Self powered millivolt receiver/valve	• No external power or batteries required to operate valve and flame modulation
• Thermostat performance	• Flame cycles and modulates such that heat output equals heat loss from the room
• Auto mode	• Flame & fan are controlled automatically
• Self powered millivolt control	• No external power required to control gas valve and flame modulation
• Integrated Valve Electronics	• No electronics, rheostat, or limit installation required
• Failure analysis	• Troubleshooting with information from LED
• Pilotstat interlock	• When valve is turned off, power unit must drop out before pilot can be relit
• F or C temperature units	• Display local temperature units

Functions

- Flame powered system
- Flame powered flame modulation
- Electronics integrated into valve to provide thermostat, flame, and fan functions with RF commands
- Temperature compensated RF receiver
- Main burner goes to "high" when manual switch is set on "local"
- Fan powered by 120 vac

Transmitter Signal

- When the transmitter is in the Auto mode, a signal is sent every 10 minutes if there is a change in the room temperature
- When the transmitter is in the On or Off modes, a signal is also sent every 10 minutes with the status of On or Off condition
- The transmitter will work at a minimum of 25 feet from the receiver
- Make sure antennae is not touching metal and is horizontal. Refer to Figure 54.

Receiver Shutdown of Burner

- In the remote, auto mode the valve shuts off if it does not receive a signal within 3 hours from the transmitter
- In the local mode the valve does not shut off
- In the remote, manual mode the valve shuts off if it does not receive a signal within 6 hours from the transmitter

Thermopiles

- The negative leads (white) must be connected to the terminals with the one white dot marked next to them
- Each thermopile must provide at least 500 mV open circuit voltage
- If output is erratic, check thermopile for intermittent shorts

LED Troubleshooting

Note: In normal operation, LED blinks once every two seconds; also, LED will be on for one second after every valid command received by the RV8310D; these are not error codes.

Failure codes (see Table) can occur anytime after the pilot burner is lit. Failure code timing is 1/4 second on, 1/2 second off.

Sequence is failure code followed by LED not blinking for four seconds.

In the event of multiple failure codes, the next failure code follows the previous failure code by approximately three seconds.

Code	Service Action
8	Replace valve
7	Confirm stepper motor connection exists
4	Fuel conversion plug missing or has poor connection (RV8310E only)
3	Replace thermopile with Q313
2	Device too hot. Check application
1	None required. This is normal operation and indicates the control is powered.

For additional Standing Pilot Troubleshooting refer to Page 30.

RF WIRING DIAGRAM

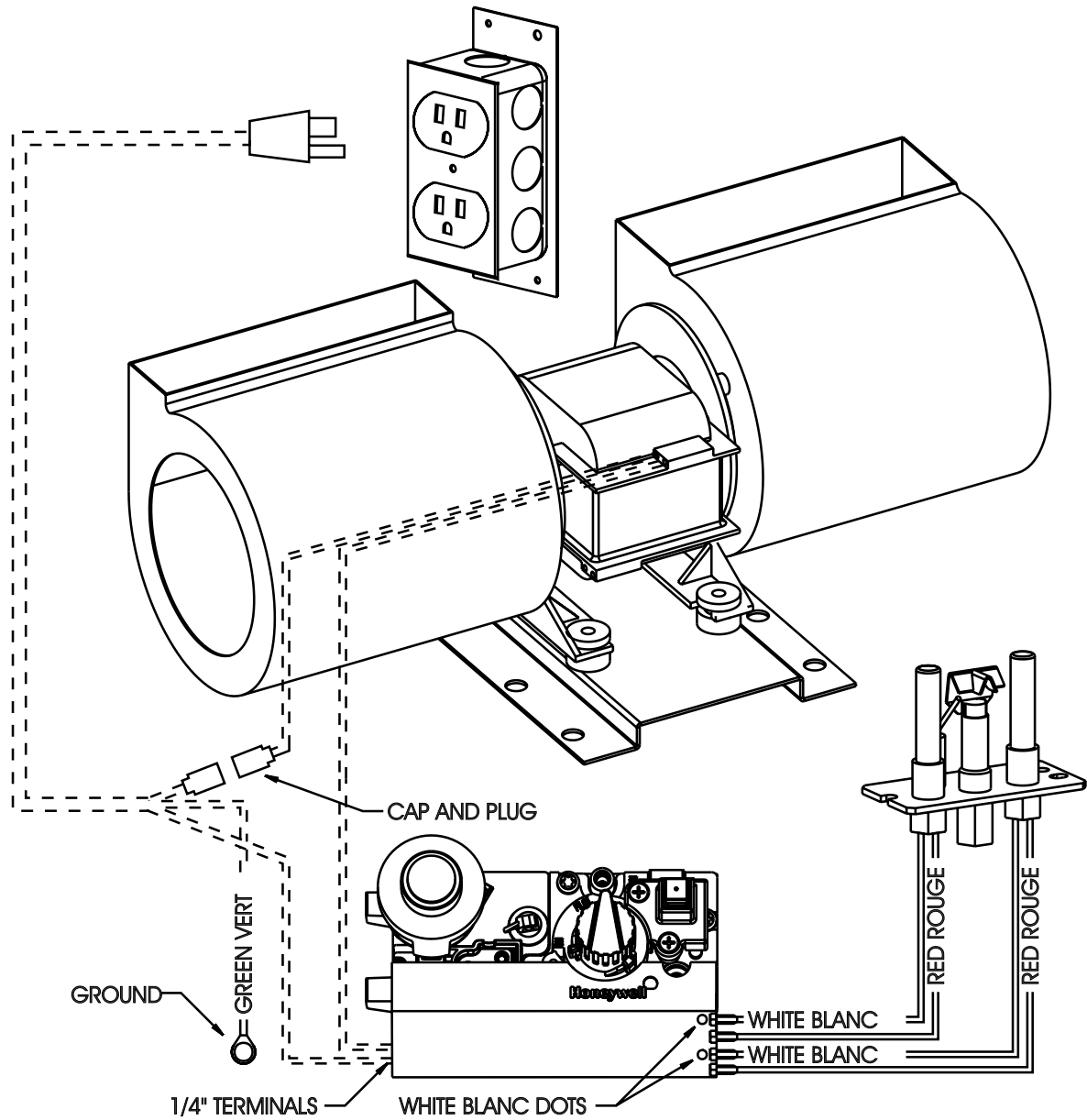

Figure 54

RF STANDING PILOT LIGHTING INSTRUCTIONS

FOR YOUR SAFETY READ BEFORE LIGHTING

WARNING: IF YOU DO NOT FOLLOW THESE INSTRUCTIONS EXACTLY, A FIRE OR EXPLOSION MAY RESULT CAUSING PROPERTY DAMAGE, PERSONAL INJURY, OR LOSS OF LIFE.

A. This appliance has a pilot which must be lighted by hand. When lighting the pilot, follow these instructions exactly.

B. BEFORE LIGHTING smell all around the appliance area for gas. Be sure to smell next to the floor because some gas is heavier than air and will settle on the floor.

WHAT TO DO IF YOU SMELL GAS

Do not try to light any appliance.

Do not touch any electrical switch;

Do not use any phone in your building.

Immediately call your gas supplier from a neighbor's phone. Follow the gas supplier's instructions.

If you can not reach your gas supplier, call the fire department.

C. Use only your hand to push in or turn the gas control knob. Never use tools. If the knob will not push in or turn by hand, don't try to repair it, call a qualified service technician. Force or attempted repair may result in a fire or explosion.

D. Do not use this appliance if any part has been under water. Immediately call a qualified service technician to inspect the appliance and to replace any part of the control system and any gas control which has been under water.

LIGHTING INSTRUCTIONS

1. STOP! Read the safety information above.

2. Turn off all electric power to the appliance. (If applicable).

3. Lower louver front assembly.

4. Push in gas control knob slightly and turn clockwise  to "OFF".

NOTE: Knob cannot be turned from "PILOT" to "OFF" unless knob is pushed in slightly. Do not force.

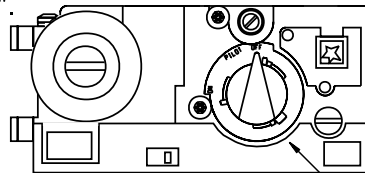



5. Wait ten (10) minutes to clear out any gas.

Then smell for gas, including near the floor.

If you smell gas, STOP! Follow "B" in the safety information above on this label. If you do not smell gas, go to the next step.

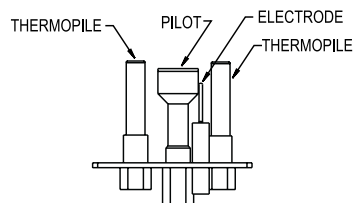
6. Find pilot - follow metal tube from gas control. The pilot is behind the middle log on the right side.



7. Turn gas control knob counterclockwise  to "PILOT".

8. Push in control knob all the way and hold in. Immediately light the pilot with the Piezo Pilot ignitor or use a match. Continue to hold the control knob in until LED blinks (one brief blink every two seconds). Holding time is about one (1) minute after the pilot is lit. Release knob, and it will pop back up. Pilot should remain lit. If it goes out, repeat steps 4 through 8.

If knob does not pop up when released, stop and immediately call a qualified service technician or gas supplier.

If the pilot will not stay lit after several tries, turn the gas control knob to "OFF" and call your service technician or gas supplier.

9. Turn gas control knob counterclockwise  to "ON".

10. Close louver front assembly.

11. Turn on all electric power to the appliance. (If applicable).

TO TURN OFF GAS TO APPLIANCE

1. Turn off all electric power to the appliance if service is to be performed (if applicable).

2. Lower louver front assembly.

3. Push in gas control knob slightly and turn clockwise  to "OFF". Do not force.

4. Close louver front assembly.

MAINTENANCE AND SERVICE

PLEASE NOTE

It is normal for appliances fabricated of steel to give off some expansion and/or contraction noised during the start up or cool down cycle. Similar noises are found with your furnace heat exchanger or car engine.

It is not unusual for your Empire gas fireplace to give off some odor the first time it is burned. This is due to the curing of the paint and any undetected oil from the manufacturing process.

Please ensure that your room is well ventilated - open all windows.

It is recommended that you burn your Empire unit for at least six (6) hours the first time you use it. If optional fan kit has been installed, place fan in the "OFF" position during this time.

IMPORTANT: Turn off gas before servicing appliance. It is recommended that a competent service technician perform these check-ups at the beginning of each heating season.

• Clean Burner and Control Compartment

Keep the control compartment, logs, and burner areas surrounding the logs clean by vacuuming or brushing at least twice a year.

Cleaning Procedure

1. Turn off pilot light at gas valve.
2. Remove glass front. (See Glass Removal)
3. Vacuum burner compartment.
4. Reinstall glass front.
5. Ignite pilot. (See Appropriate Pilot Lighting Instructions)
6. Operate the pilot burner. If it appears abnormal call a service person.

• Check Vent System

The appliance and venting system should be inspected before initial use and at least annually by a qualified field service person. Inspect the external vent cap on a regular basis to make sure that no debris is interfering with the air flow.

Glass Cleaning

It will be necessary to clean the glass periodically. During start-up condensation, which is normal, forms on the inside of the glass and causes lint, dust and other airborne particles to cling to the glass surface. Also initial paint curing may deposit a slight film on the glass. It is therefore recommended that the glass be cleaned two or three times with a non-abrasive household cleaner and warm water (we recommend gas fireplace glass cleaner). After that the glass should be cleaned two or three times during each heating season depending on the circumstances present.

General Glass Information

WARNING: Do not operate appliance with the glass front removed, cracked or broken. Replacement of the glass should be done by a licensed or qualified service person.

Only glass approved for use by the manufacturer in fireplace may be used for replacement. The glass replacement should be done by a licensed or qualified service person.

WARNING:

1. The use of substitute glass will void all product warranties.
2. Care must be taken to avoid breakage of the glass.
3. Under no circumstances should this appliance be operated without the glass front or with a broken glass front. Replacement of the glass (with gasket) as supplied by the manufacturer should be done by a qualified service person.
4. Do not abuse the glass by striking or hitting the glass.

WARNING: Do not use abrasive cleaners on glass. Do not attempt to clean glass when glass is hot.

Glass Removal and Replacement (Figure 55)

1. Push up and outward to remove top louver.
2. Lower door assembly.
3. Release two door latches at bottom of firebox.
4. Grasp bottom of glass frame, lift glass frame upward in order to release glass frame from lip on top of firebox.
5. Align and place top of glass frame over lip on top of firebox.
6. Grasp bottom of glass frame, push inward and place glass frame onto firebox.
7. Attach two door latches onto bottom of glass frame.
8. Align and insert (4) mounting tabs on top louver with (4) slots on casing top. Push downward to lock the top louver into position.

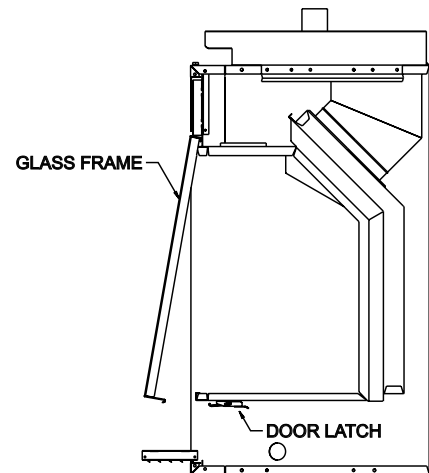
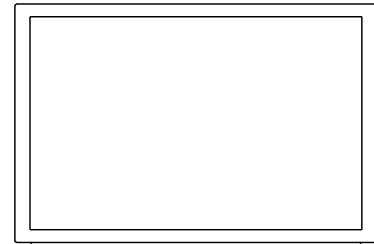

Figure 55

Installation of Louvers (Figure 56)

Attention: The top louver has (4) mounting tabs. The bottom louver has (2) clearance holes.

1. Align and insert (4) mounting tabs on top louver with (4) slots on casing top. Push downward to lock the top louver into position.
2. Align (2) clearance holes on bottom louver with (2) screw holes on casing. Attach bottom louver to casing with (2) 10 x 1/2" screws.

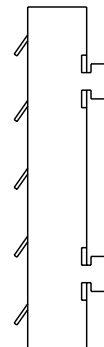

Figure 56

HOW TO ORDER REPAIR PARTS

Parts can be ordered **only** through your **service person or dealer**. For best results, the **service person or dealer** should order parts through the distributor. Parts can be shipped directly to the **service person/dealer**.

All parts listed in the Parts List have a Part Number. When ordering parts, first obtain the Model Number from the name plate on your equipment. Then determine the Part Number (**not** the Index Number) and the Description of each part from the following appropriate illustration and list. Be sure to give all this information . . .

Fireplace Number _____ Part Description _____

Fireplace Serial Number _____ Part Number _____

Type of Gas (Propane or Natural) _____

Do not order bolts, screws, washers or nuts. They are standard hardware items and can be purchased at any local hardware store.

Shipments contingent upon strikes, fires and all causes beyond our control.

Empire Comfort Systems, Inc. Nine Eighteen Freeburg Ave. Belleville, Illinois 62222-0529

DVS-30 PARTS LIST

INDEX NO.	PART NUMBER	DESCRIPTION	INDEX NO.	PART NUMBER	DESCRIPTION
1	11785	UPPER CLEARANCE SPACER	37	P-253	ORIFICE FITTING
2	10285	TOP STANDOFF (2 REQ'D)	38	P-182	#55 ORIFICE - LP
3	11265	VENT COVER PLATE ASSEMBLY	38	P-252	#44 ORIFICE - NAT
4	11264	OUTER WRAPPER TOP	39	R-5676	AIR SHUTTER
5	11263	TOP HEAT SHIELD	40	P-251	COUPLING (NAT GAS ONLY)
6	10281	OUTER WRAPPER - LEFT	41	12356	BURNER BOX ASSEMBLY
7	11240	OUTER WRAPPER BACK	42	11543	BURNER SUPPORT - LEFT
8	10282	OUTER WRAPPER - RIGHT	43	11279	BURNER SUPPORT - RIGHT
9	10779	CORNER SHIELD	45	R-5705	PILOT ASSEMBLY - NATURAL (DVS-30)
11	10018	AIR DILLUTION COVER PLATE	45	R-5706	PILOT ASSEMBLY - LP (DVS-30)
12	10574	CORNER BRACE 2	45a	R-5710	THERMOPILE (DVS-30)
13	10573	CORNER BRACE 1	45b	R-5709	THERMOCOUPLE (DVS-30)
14	12217	OUTER WRAPPER BOTTOM WELDED ASSEMBLY	46	R-6116	PILOT ASSEMBLY - NATURAL (DVS-30RF)
15	10590	LOUVER ASSEMBLY - UPPER	46	R-6117	PILOT ASSEMBLY - LP (DVS-30RF)
16	11267	GLASS FRAME ASSEMBLY	46a	R-6761	THERMOPILE (2 REQ'D) (DVS-30RF)
17	10591	LOUVER ASSEMBLY - LOWER	47b	11245	FIREBOX BOTTOM WELDED ASSEMBLY
18	R-6106	ADAPTER PIPE	48	R-4053	DOOR LATCH (2 REQ'D)
19	M-160	6 5/8" ADAPTER GASKET	49b	R-5454	GAS VALVE - NATURAL (DVS-30)
20	11261	AIR DROP BACK ASSEMBLY	49b	R-5455	GAS VALVE - LP (DVS-30)
21	10554	NAILING FLANGE (4 REQ'D)	49c	R-6114	GAS VALVE - NATURAL (DVS-30RF)
22	11259	AIR DROP FRONT ASSEMBLY	49c	R-6115	GAS VALVE - LP (DVS-30RF)
23	11250	PRESSURE DOOR RELEIF ASSEMBLY	50	M-173	PILOT GASKET
24	11252	PRESSURE RELEIF BRACKET (2 REQ'D)	57	R-3436	REMOTE/OFF/ON SWITCH (DVS-30)
25	M-163	FLUE CONNECTOR TUBE GASKET	58	11663	VALVE BRACKET (2 REQ'D) (DVS-30RF)
26	10994	DIVERTER OUTLET SUPPORT	59	R-6110	LOG - LEFT FRONT
27	11247	FIREBOX TOP ASSEMBLY	60	R-6109	LOG - RIGHT FRONT
28	11253	COMBUSTION DOME DIVERTER	61	R-6111	LOG - MIDDLE
30	11257	SUPPORT COLUMN - LEFT	62	R-6113	LOG - BRANCH
31	11254	FIREBOX SIDE - LEFT	63	R-6112	LOG - REAR
32	11255	FIREBOX SIDE - RIGHT	NOT SHOWN	11281	VENTURI TARGET (NAT ONLY)
33	11258	SUPPORT COLUMN - RIGHT	NOT SHOWN	R-3435A	WIRE ASSEMBLY (DVS-30)
34	11256	FIREBOX BACK	NOT SHOWN	13097	INLET TUBING ASSEMBLY (DVS-30))
35	11645	REAR LOG SUPPORT	NOT SHOWN	11664	INLET TUBING ASSEMBLY (DVS-30RF)
36	11646	GRATE ASSEMBLY (2 REQ'D)	NOT SHOWN	R-6118	REMOTE CONTROL (DVS-30RF)
			NOT SHOWN	11495	SHIPPING PLATE
			NOT SHOWN	11788	DECORATIVE ROCK
			NOT SHOWN	11548	ROCK WOOL (1 REQ'D)
			NOT SHOWN	R-4459	MAGNET (2 REQ'D)

USE ONLY MANUFACTURER'S REPLACEMENT PARTS. USE OF ANY OTHER PARTS COULD CAUSE INJURY OR DEATH.

DVS-36 PARTS LIST

INDEX NO.	PART NUMBER	DESCRIPTION	INDEX NO.	PART NUMBER	DESCRIPTION
1	11785	UPPER CLEARANCE SPACER	39	R-5698	AIR SHUTTER
2	11450	TOP STANDOFF (2 REQ'D)	40	P-251	COUPLING (NAT GAS ONLY)
3	10988	VENT COVER PLATE ASSEMBLY	41	12320	BURNER BOX ASSEMBLY
4	11406	OUTER WRAPPER TOP	42	11499	BURNER SUPPORT - LEFT
5	10776	TOP HEAT SHIELD	43	11377	BURNER SUPPORT - RIGHT
6	11404	OUTER WRAPPER - LEFT	44	R-5747	PILOT ASSEMBLY - NATURAL (DVS-36IP)
7	11403	OUTER WRAPPER BACK	44	R-5748	PILOT ASSEMBLY - LP (DVS-36IP)
8	11405	OUTER WRAPPER - RIGHT	45	R-5705	PILOT ASSEMBLY - NATURAL (DVS-36)
9	10779	CORNER SHIELD	45	R-5706	PILOT ASSEMBLY - LP (DVS-36)
10	10054	JUNCTION BOX WELDED ASSEMBLY (DVS-36IP)	45a	R-5710	THERMOPILE (DVS-36)
11	10018	AIR DILLUTION COVER PLATE	45b	R-5709	THERMOCOUPLE (DVS-36)
12	10574	CORNER BRACE 2	46	R-6116	PILOT ASSEMBLY - NATURAL (DVS-36RF)
13	10573	CORNER BRACE 1	46	R-6117	PILOT ASSEMBLY - LP (DVS-36RF)
14	11521	OUTER WRAPPER BOTTOM WELDED ASSEMBLY (DVS-36)	46a	R-6761	THERMOPILE (2 REQ'D) (DVS-36RF)
14	13098	OUTER WRAPPER BOTTOM WELDED ASSEMBLY (DVS-36IP)	47a	11439	FIREBOX BOTTOM WELDED ASSEMBLY (DVS-36-IP)
14	13099	OUTER WRAPPER BOTTOM WELDED ASSEMBLY (DVS-36RF)	47b	11770	FIREBOX BOTTOM WELDED ASSEMBLY (DVS-36 DVS-36RF)
15	10586	LOUVER ASSEMBLY - UPPER	48	R-4053	DOOR LATCH (2 REQ'D)
16	10898	GLASS FRAME ASSEMBLY	49a	R-5745	GAS VALVE - NATURAL (DVS-36IP)
17	10587	LOUVER ASSEMBLY - LOWER	49a	R-5746	GAS VALVE - LP (DVS-36IP)
18	R-5137	ADAPTER PIPE	49b	R-5454	GAS VALVE - NATURAL (DVS-36)
19	M-169	8" ADAPTER GASKET	49b	R-5455	GAS VALVE - LP (DVS-36)
20	10900	AIR DROP BACK ASSEMBLY	49c	R-6114	GAS VALVE - NATURAL (DVS-36RF)
21	10554	NAILING FLANGE (4 REQ'D)	49c	R-6115	GAS VALVE - LP (DVS-36RF)
22	11222	AIR DROP FRONT ASSEMBLY	50	M-173	PILOT GASKET
23	CI-364	BLOW PLATE ASSEMBLY	51	UH-810	TRANSFORMER MOUNTING BRACKET (DVS-36IP)
24	11452	BLOW PLATE BRACKET (2 REQ'D)	52	R-1995	TRANSFORMER (DVS-36IP)
25	M-170	FLUE OUTLET GASKET	53	UH-451	JUNCTION BOX COVER (DVS-36IP)
26	10976	DIVERTER OUTLET TUBE	54	UH-273	JUNCTION BOX (DVS-36IP)
27	10893	FIREBOX TOP ASSEMBLY	55	R-5160	CORD SET - 18" (DVS-36IP)
28	10798	COMBUSTION DOME DIVERTER	56	R-1616	MODULE (DVS-36IP)
29	10993	HEATER BAFFLE	57	R-3436	REMOTE/OFF/ON SWITCH (DVS-36)
30	11218	SUPPORT COLUMN - LEFT	58	11663	VALVE BRACKET (2 REQ'D) (DVS-36RF)
31	10788	FIREBOX SIDE - LEFT	59	R-6391	LOG - LEFT FRONT
32	10789	FIREBOX SIDE - RIGHT	60	R-5731	LOG - RIGHT FRONT
33	11219	SUPPORT COLUMN - RIGHT	61	R-5732	LOG - MIDDLE
34	11453	FIREBOX BACK	62	R-5734	LOG - BRANCH
35	11825	REAR LOG SUPPORT	63	R-6392	LOG - REAR
36	11371	GRATE ASSEMBLY (2 REQ'D)	NOT SHOWN	R-3435A	WIRE ASSEMBLY (DVS-36)
37	P-253	ORIFICE FITTING	NOT SHOWN	11440	INLET TUBING ASSEMBLY (DVS-36IP)
38	P-255	#53 ORIFICE - LP	NOT SHOWN	11413	INLET TUBING ASSEMBLY (DVS-36)
38	P-256	#41 ORIFICE - NAT	NOT SHOWN	11665	INLET TUBING ASSEMBLY (DVS-36RF)
			NOT SHOWN	R-6118	REMOTE CONTROL (DVS-36RF)
			NOT SHOWN	11497	SHIPPING PLATE
			NOT SHOWN	11788	DECORATIVE ROCK
			NOT SHOWN	11548	ROCK WOOL (2 REQ'D)
			NOT SHOWN	R-5751	WIRE ASSEMBLY (DVS-36IP)
			NOT SHOWN	R-721B	WIRE HARNESS (DVS-36IP)
			NOT SHOWN	R-4459	MAGNET (2 REQ'D)

USE ONLY MANUFACTURER'S REPLACEMENT PARTS. USE OF ANY OTHER PARTS COULD CAUSE INJURY OR DEATH.

DVS-42 PARTS LIST

INDEX NO.	PART NUMBER	DESCRIPTION	INDEX NO.	PART NUMBER	DESCRIPTION
1	11785	UPPER CLEARANCE SPACER	38	P-257	#40 ORIFICE - NAT
2	11451	TOP STANDOFF (2 REQ'D)	39	R-5698	AIR SHUTTER
3	10988	VENT COVER PLATE ASSEMBLY	40	P-251	COUPLING (NAT GAS ONLY)
4	11425	OUTER WRAPPER TOP	41	12338	BURNER BOX ASSEMBLY
5	10777	TOP HEAT SHIELD	42	11499	BURNER SUPPORT - LEFT
6	11423	OUTER WRAPPER - LEFT	43	11377	BURNER SUPPORT - RIGHT
7	11422	OUTER WRAPPER BACK	44	R-5747	PILOT ASSEMBLY - NATURAL (DVS-42IP)
8	11424	OUTER WRAPPER - RIGHT	44	R-5748	PILOT ASSEMBLY - LP (DVS-42IP)
9	10779	CORNER SHIELD	45	R-5705	PILOT ASSEMBLY - NATURAL (DVS-42)
10	10054	JUNCTION BOX WELDED ASSEMBLY (DVS-42IP)	45	R-5706	PILOT ASSEMBLY - LP (DVS-42)
11	10018	AIR DILLUTION COVER PLATE	45a	R-5710	THERMOPILE (DVS-42)
12	10574	CORNER BRACE 2	45b	R-5709	THERMOCOUPLE (DVS-42)
13	10573	CORNER BRACE 1	46	R-6116	PILOT ASSEMBLY - NATURAL (DVS-42RF)
14	11420	OUTER WRAPPER BOTTOM WELDED ASSEMBLY (DVS-42)	46	R-6117	PILOT ASSEMBLY - LP (DVS-42RF)
14	13100	OUTER WRAPPER BOTTOM WELDED ASSEMBLY (DVS-42IP)	46a	R-6761	THERMOPILE (2 REQ'D) (DVS-42RF)
14	13101	OUTER WRAPPER BOTTOM WELDED ASSEMBLY (DVS-42RF)	47a	11447	FIREBOX BOTTOM WELDED ASSEMBLY (DVS-42-IP)
15	10588	LOUVER ASSEMBLY - UPPER	47b	11771	FIREBOX BOTTOM WELDED ASSEMBLY (DVS-42 DVS-42RF)
16	10951	GLASS FRAME ASSEMBLY	48	R-4053	DOOR LATCH (2 REQ'D)
17	10589	LOUVER ASSEMBLY - LOWER	49a	R-5745	GAS VALVE - NATURAL (DVS-42IP)
18	R-5137	ADAPTER PIPE	49a	R-5746	GAS VALVE - LP (DVS-42IP)
19	M-169	8" ADAPTER GASKET	49b	R-5454	GAS VALVE - NATURAL (DVS-42)
20	10900	AIR DROP BACK ASSEMBLY	49b	R-5455	GAS VALVE - LP (DVS-42)
21	10554	NAILING FLANGE (4 REQ'D)	49c	R-6114	GAS VALVE - NATURAL (DVS-42RF)
22	11222	AIR DROP FRONT ASSEMBLY	49c	R-6115	GAS VALVE - LP (DVS-42RF)
23	10945	PRESSURE DOOR RELEIF ASSEMBLY (2 REQ'D)	50	M-173	PILOT GASKET
24	11452	BLOW PLATE BRACKET (4 REQ'D)	51	UH-810	TRANSFORMER MOUNTING BRACKET (DVS-42IP)
25	M-170	FLUE OUTLET GASKET	52	R-1995	TRANSFORMER (DVS-42IP)
26	10976	DIVERTER OUTLET TUBE	53	UH-451	JUNCTION BOX COVER (DVS-42IP)
27	10944	FIREBOX TOP ASSEMBLY	54	UH-273	JUNCTION BOX (DVS-42IP)
28	10799	COMBUSTION DOME DIVERTER	55	R-5160	CORD SET - 18" (DVS-42IP)
29	10993	HEATER BAFFLE	56	R-1616	MODULE (DVS-42IP)
30	11220	SUPPORT COLUMN - LEFT	57	R-3436	REMOTE/OFF/ON SWITCH (DVS-42)
31	10790	FIREBOX SIDE - LEFT	58	11663	VALVE BRACKET (2 REQ'D) (DVS-42RF)
32	10791	FIREBOX SIDE - RIGHT	59	R-5736	LOG - LEFT FRONT
33	11221	SUPPORT COLUMN - RIGHT	60	R-5737	LOG - RIGHT FRONT
34	11454	FIREBOX BACK	61	R-5738	LOG - MIDDLE
35	11379	REAR LOG SUPPORT	62	R-5740	LOG - BRANCH
36	11371	GRATE ASSEMBLY (2 REQ'D)	63	R-7139	LOG - REAR
37	P-253	ORIFICE FITTING	NOT SHOWN	11281	VENTURI TARGET (NAT ONLY)
38	P-258	#1.55mm ORIFICE - LP	NOT SHOWN	R-3435A	WIRE ASSEMBLY (DVS-42)
			NOT SHOWN	11440	INLET TUBING ASSEMBLY (DVS-42IP)
			NOT SHOWN	11413	INLET TUBING ASSEMBLY (DVS-42)
			NOT SHOWN	11666	INLET TUBING ASSEMBLY (DVS-42RF)
			NOT SHOWN	R-6118	REMOTE CONTROL (DVS-42RF)
			NOT SHOWN	11498	SHIPPING PLATE
			NOT SHOWN	11788	DECORATIVE ROCK
			NOT SHOWN	11548	ROCK WOOL (2 REQ'D)
			NOT SHOWN	R-5751	WIRE ASSEMBLY (DVS-42IP)
			NOT SHOWN	R-721B	WIRE HARNESS (DVS-42IP)
			NOT SHOWN	R-4459	MAGNET (2 REQ'D)

USE ONLY MANUFACTURER'S REPLACEMENT PARTS. USE OF ANY OTHER PARTS COULD CAUSE INJURY OR DEATH.

PARTS VIEW

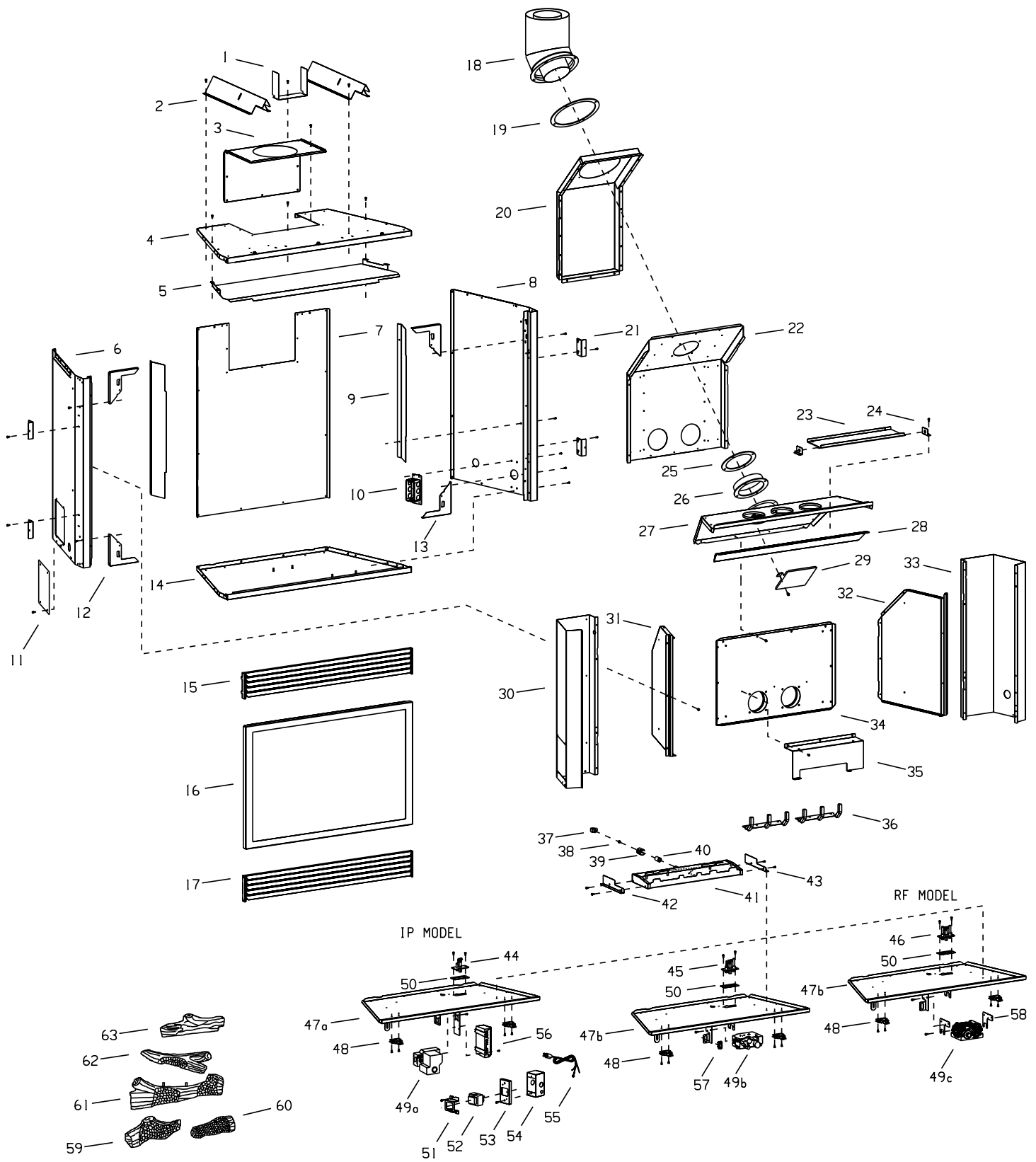

ACCESSORY PARTS

The following accessory parts can be obtained from your Empire Comfort Systems, dealer. Should you need additional information beyond what your dealer can furnish, contact Empire Comfort Systems, Inc., Nine Eighteen Freeburg Ave., Belleville, Illinois 62222-0529.

Accessory	Description	Model Number
<p>Fan Kit</p> <p>FB-BK-2 FBB1A</p>	<p>Designed to provide forced air flow.</p>	<p>Variable Speed FKA-160</p> <p>Single Speed FBB1A</p>
<p>Simulated Brick Panels</p>	<p>Designed to enhance appearance looking more like real masonry.</p>	<p>DVS-BL-30 DVS-BL-36 DVS-BL-42 DVP1A-30-1 DVP1A-36-1 DVP1A-42-1</p>
<p>Fresh Air Intake Kit</p>	<p>Designed to provide heated fresh air to the house.</p>	<p>DVFB-AK-30 FB-AK-2</p>
<p>Trim Kit</p>	<p>Frame — Brass</p> <p>Frame — High Gloss Black</p> <p>Frame — Black</p>	<p>DVSBF-36BR-1 DVSBF-42BR-1 DVSBF-42BR-1</p> <p>FBF-30BP-2 FBF-36BP-2 FBF-42BP-2</p> <p>FBF-30BL-2 FBF-36BL-2 FBF-42BL-2</p>
<p>Louvers</p> <p>UPPER LOUVER</p> <p>LOWER LOUVER</p>	<p>Brass Louvers</p> <p>High Gloss Black Louvers</p>	<p>FBL-30BR-2 FBL-36BR-2 FBL-42BR-2</p> <p>FBL-30BP-2 FBL-36BP-2 FBL-42BP-2</p>
	<p>Brass Window Trim</p>	<p>DVWT-30BR-1 DVWT-36BR-1 DVWT-42BR-1</p>
	<p>Junction Box</p>	<p>FJB-1</p>

VARIABLE SPEED BLOWER INSTALLATION INSTRUCTIONS

Optional FB-BK-2 Blower Installation and Factory Installed FB-BK-RF Blower

1. If applicable, turn OFF electric supply to fireplace.
2. Lower bottom louver.
3. With a 5/16" socket, loosen but do not remove either left screw or right screw that attaches bottom louver to fireplace side.
4. When the screw is sufficiently loosened you will be able to pull and pivot the bottom louver out of fireplace.
5. Centered in the rear are two (2) weld studs which protrude upward into the bottom of fireplace for attachment of fan.
6. Insert fan into interior, bottom of fireplace. The clearance holes on fan mounting bracket must be facing toward the front of fireplace. Do not damage gas inlet supply line when fan is inserted into fireplace.
7. Align and place rear set of clearance holes on fan mounting bracket onto two (2) weld studs for direct vent 36/42 models or front set of clearance holes on fan mounting bracket onto two (2) weld studs for other models.
8. Use two (2) wing nuts to attach blower to weld studs.
9. Depending on the appliance, you will remove the top louver(s) by one of the following methods.

First Method, Push up and outward to remove top louver.

Second Method, Remove top louvers by grasping an individual louver at each end and pivoting louver out of frame. Remove three (3) additional louvers in this same manner.

Attention: Steps 10 through 17 DO NOT apply to RF models.

10. Located in the right, front are two (2) weld studs which protrude upward into the bottom of fireplace for attachment of speed control.
11. Insert speed control into interior, bottom of fireplace. Align and place two (2) clearance holes on speed control onto two (2) weld studs.
12. Use two (2) wing nuts to attach speed control to weld studs.
13. Refer to Figure 1 for mounting hole location on right side of firebox top that applies to your appliance. Measure from front edge of firebox top to determine mounting hole location. Remove appropriate screw from firebox top.
14. Refer to Figure 2 for fan control bracket location that applies to your firebox. Align clearance hole on fan control bracket with screw hole on firebox top. Attach fan control bracket to firebox top with one (1) screw from Step 13.
15. Route fan control wires between the inner casing and outer casing.
16. Connect fan control wires to speed control wires.
17. Plug speed control electric cord into junction box on the right side of fireplace.
18. **For RF Models only,** insert one (1) 1/4" terminal wire from RF cordset and one (1) 1/4" terminal wire from blower motor into gas valve. Insert cap wire into plug wire from cordset and blower motor. Secure ground wire.
19. Depending on the appliance, you will replace the top louver(s) by one of the following methods.

First Method, Align and insert (4) mounting tabs on top louver with (4) slots on casing top. Push downward to lock the top louver into position.

Second Method, Install top louvers by grasping an individual louver at each end and pivoting louver onto end brackets on frame. Install three (3) additional louvers in this same manner.

20. Replace bottom louver.
21. Installation of blower is completed.

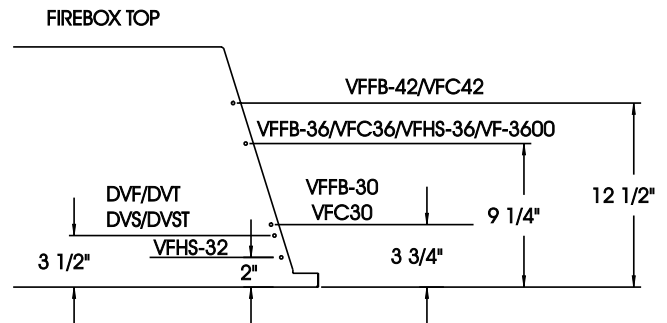

Figure 1

VFFB/VFC UNITS
VFHS-32 UNITS
VFHS-36/VF-3600 UNITS

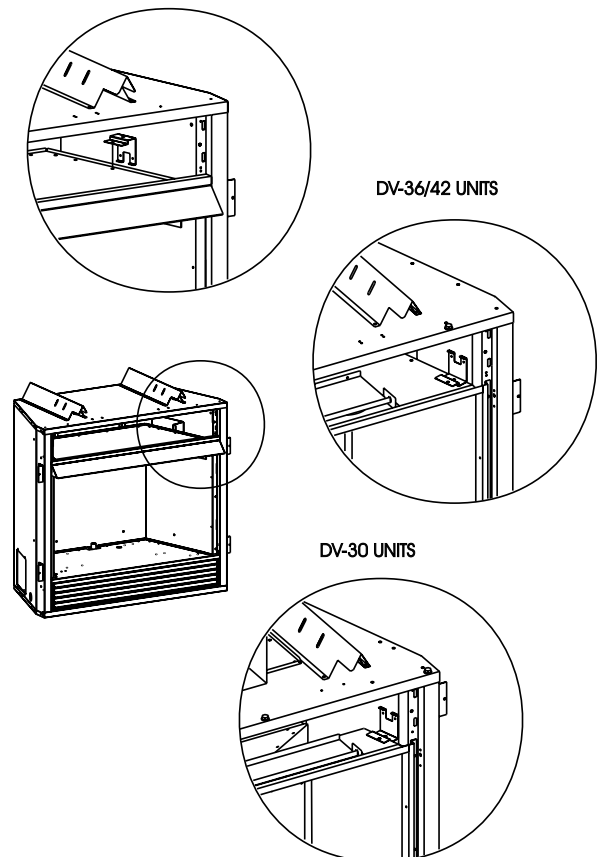
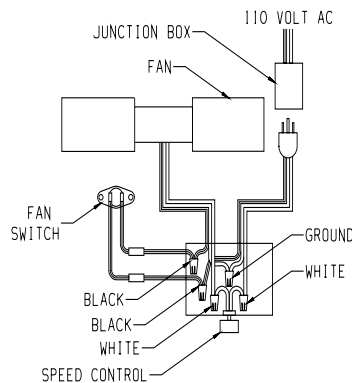
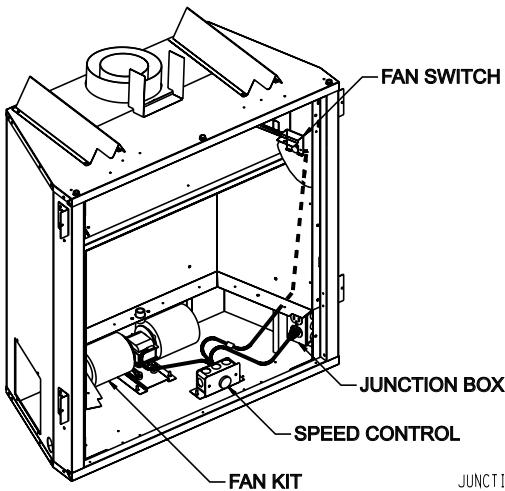

Figure 2

Wiring

The appliance, when installed, must be electrically grounded in accordance with local codes or, in the absence of local codes, with the *National Electrical Code, ANSI/NFPA 70*, if an external electrical source is utilized. **This appliance is equipped with a three-prong [grounding] plug for your protection against shock hazard and should be plugged directly into a properly grounded three-prong receptacle. Do not cut or remove the grounding prong from this plug.** For an ungrounded receptacle, an adapter, which has two prongs and a wire for grounding, can be purchased, plugged into the ungrounded receptacle and its wire connected to the receptacle mounting screw. With this wire completing the ground, the appliance cord plug can be plugged into the adapter and be electrically grounded.

CAUTION: Label all wires prior to disconnection when servicing controls. Wiring errors can cause improper and dangerous operation. Verify proper operation after servicing.



FB-BK-2 Parts List

- 1 R-4190 BLOWER ASSEMBLY
- 2 10758 FAN CONTROL BRACKET
- 3 R-2503 FAN CONTROL
- 4 R-5101 WIRE HARNESS
- 5 R-5298 WIRE ASSEMBLY
- 6 R-3490 JUNCTION BOX
- 7 10088 RHEOSTAT BOX BRACKET
- 8 R-4192 RHEOSTAT KNOB
- 9 R-4186 RHEOSTAT
- 10 R-4193 CORD SET
- 11 10849 BLOWER SUPPORT
- NS 10146 BLOWER GASKET (2 REQ'D)
- NS R-1410 STRAIN RELIEF BUSHING
- NS R-1720 CABLE CLIP

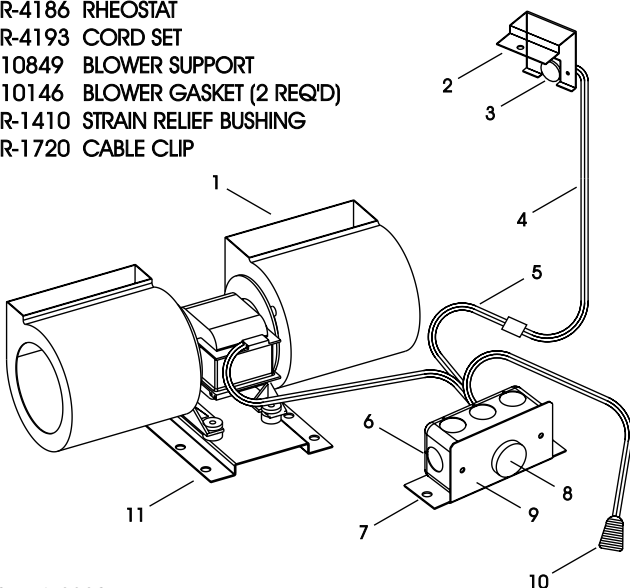

Blower Motor

The blower motor does not have oiling holes. Do not attempt to oil the blower motor.

Blower Wheels

The blower wheels will collect lint and could require periodic cleaning. If the air output decreases or the noise level increases, it indicates a dirty blower wheel. Remove fan and clean blower wheels.

WARNING:

Unplugging of blower accessory will not stop the heater from cycling. To turn off gas to the heater: Push in gas control knob slightly and turn clockwise to "OFF." Do not force.

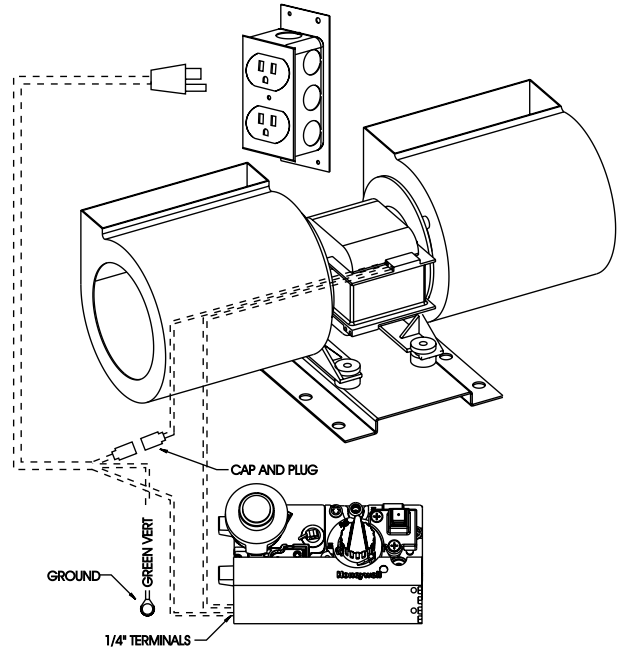

FB-BK-RF Parts List

Part Description	Part Number	Quantity Supplied
Fan Kit	R-6158	1
Cord Set	R-6159	1
Hardware Package	11676	1

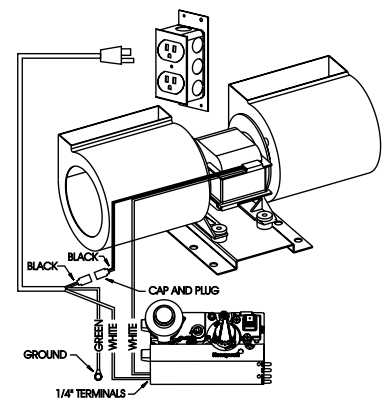

OPTIONAL SINGLE SPEED BLOWER INSTALLATION INSTRUCTIONS

FBB1A Blower Installation

1. If applicable, turn OFF electric supply to fireplace.
2. Lower bottom louver.
3. With a 5/16" socket, loosen but do not remove either left screw or right screw that attaches bottom louver to fireplace side.
4. When the screw is sufficiently loosened you will be able to pull and pivot the bottom louver out of fireplace.
5. Place blower assembly into bottom of fireplace.
6. Insert blower support into mounting tabs on fireplace bottom for 30 model. **Attention:** The 36/42 models do not have mounting tabs on fireplace bottom. Use front set of clearance holes on blower support for 30 model. The 36/42 models use rear set of clearance holes on blower support as you place blower support onto two (2) weld studs at rear of fireplace bottom. Attach two (2) wing nuts onto weld studs.
7. Place switch bracket onto two (2) weld studs located at front of the fireplace bottom. Attach two (2) wing nuts onto weld studs.
8. Push up and outward to remove top louver.
9. Refer to Figure 1 for mounting hole location on right side of firebox top that applies to your appliance. Measure from front edge of firebox top to determine mounting hole location. Remove appropriate screw from firebox top.
10. Refer to Figure 2 for fan control bracket location that applies to your firebox. Align clearance hole on fan control bracket with screw hole on firebox top.
11. Attach fan control bracket to firebox top with screw from Step 9.
12. Route fan control wire harness between inner casing and outer casing.
13. Attach one (1) cord set wire to one (1) blower assembly wire.
14. Attach one (1) cord set wire to one (1) fan control wire.
15. Attach one (1) blower assembly wire to one (1) fan control wire.
16. Align and insert (4) mounting tabs on top louver with (4) slots on casing top. Push downward to lock the top louver into position.
17. Replace bottom louver.
18. Installation of FBB1A single speed blower is completed.

Fan Control Operation

Turn switch to ON position to activate fan control. On maximum input, blower will operate after 4 to 6 minutes of main burner ignition.

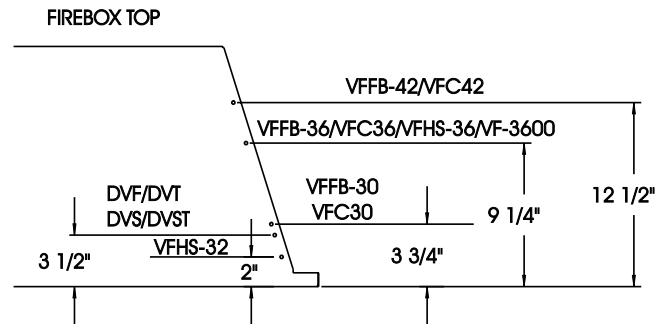

Figure 1

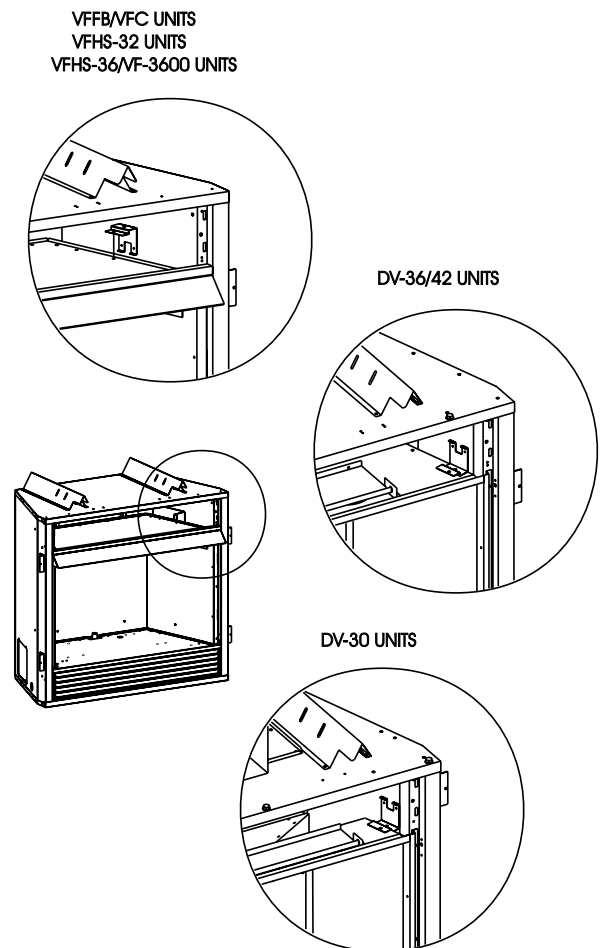

Figure 2

Wiring

The appliance, when installed, must be electrically grounded in accordance with local codes or, in the absence of local codes, with the *National Electrical Code ANSI/NFPA No. 70*, if an external electrical source is utilized. **This appliance is equipped with a three-prong [grounding] plug for your protection against shock hazard and should be plugged directly into a properly grounded three-prong receptacle. Do not cut or remove the grounding prong from this plug.** For an ungrounded receptacle, an adapter, which has two prongs and a wire for grounding, can be purchased, plugged into the ungrounded receptacle and its wire connected to the receptacle mounting screw. With this wire completing the ground, the appliance cord plug can be plugged into the adapter and be electrically grounded.

CAUTION: Label all wires prior to disconnection when servicing controls. Wiring errors can cause improper and dangerous operation. Verify proper operation after servicing.

Blower Motor

The blower motor does not have oiling holes. Do not attempt to oil the blower motor.

Blower Wheels

The blower wheels will collect lint and could require periodic cleaning. If the air output decreases or the noise level increases, it indicates a dirty blower wheel. Remove blower and clean blower wheels.

WARNING:

Unplugging of blower accessory will not stop the heater from cycling. To turn off gas to the unvented heater: Push in gas control knob slightly and turn clockwise to "OFF." Do not force.

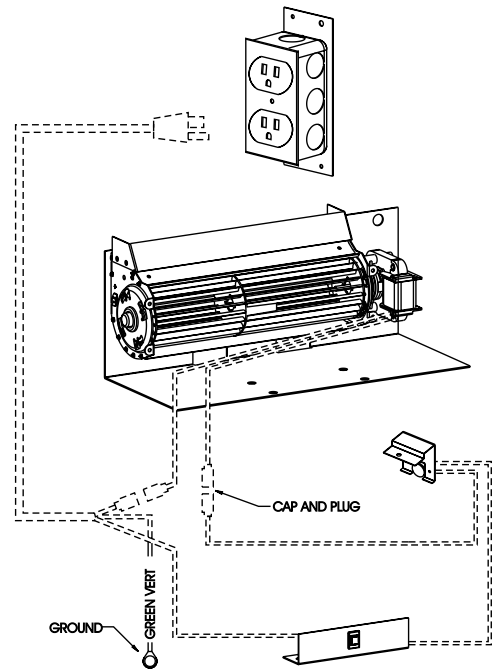
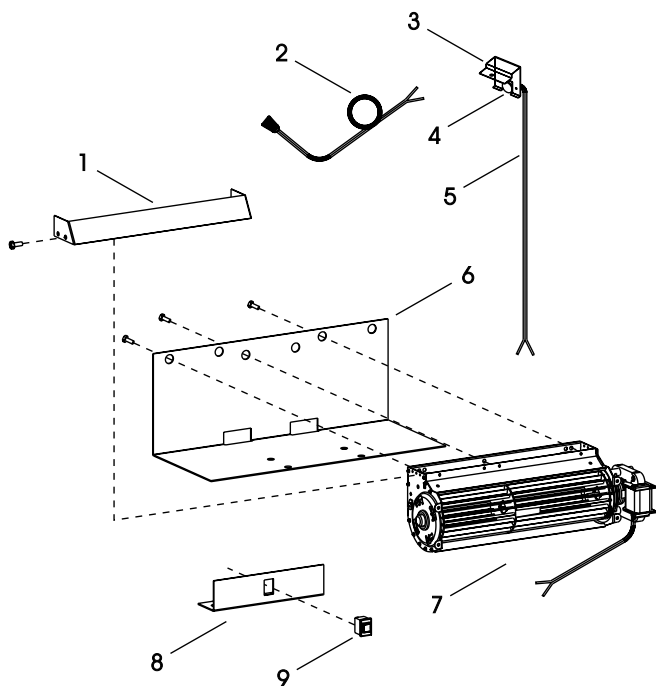

Figure 3



PARTS LIST

INDEX NUMBER	PART NUMBER	DESCRIPTION	QUANTITY SUPPLIED
1	11935	BLOWER DIVERTOR	1
2	R-6458	CORD SET	1
3	10758	FAN CONTROL BRACKET	1
4	R-2503	FAN CONTROL	1
5	R-6459	WIRE HARNESS	1
6	11932	BLOWER SUPPORT	1
7	R-6460	BLOWER ASSEMBLY	1
8	11933	SWITCH BRACKET	1
9	R-6461	SWITCH	1
NS	10146	BLOWER GASKET	2
NS	R-1720	CABLE CLIP	1
NS	R-1499	GROMMETS	3
NS	R-1454	BUSHING	3

OPTIONAL FRESH AIR INTAKE INSTALLATION INSTRUCTIONS

OPTIONAL FRESH AIR INTAKE KIT

DVFB-AK-30, FB-AK-2

Optional Fresh Air Intake Kit (Figure 1)

Installation of our 6" fresh air intake kit is simple and easy to complete. This system **MUST BE** installed before the fireplace is enclosed with finishing material. The air will be drawn into the cooling layer of the fireplace and be completely separated from the combustion casing of the direct vent fireplace. Cooler outside air will mix with room air, circulating around the firebox to reduce the heat output and bring heated, fresh air into the house to provide a more positive balance.

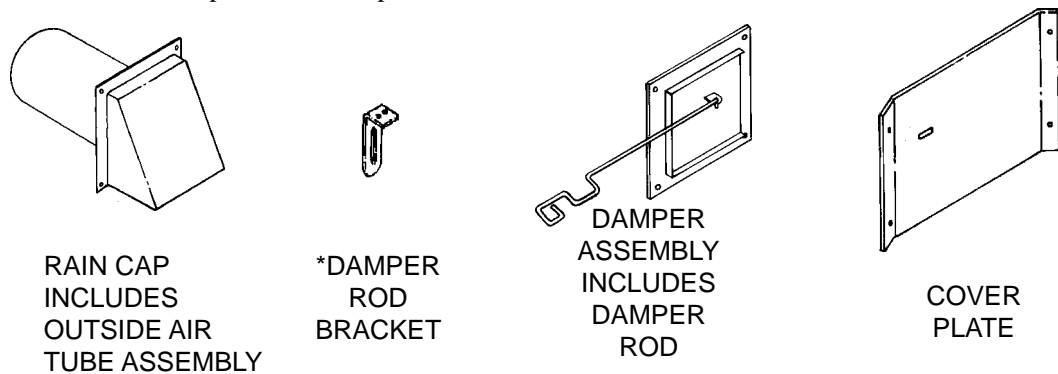

Figure 1 Fresh Air Intake Kit

Installing Fresh Air Intake Kit (Figures 2, 3, 4, 5, 6)

1. Remove air dilution cover plate from left side of outer casing by removing (4) 10 x 1/2" screws (See Figure 2).
2. Attach damper assembly onto left side of outer casing with (4) 10 x 1/2" screws from Step 1. The 3" damper door tab will be positioned to the right as the damper assembly is attached to left side of outer casing.
3. As you face the fireplace, insert damper rod bracket into left, interior bottom of fireplace for 36/42 models. The 3/4" flange on damper rod bracket must face toward the rear of fireplace. Align (2) clearance holes on damper rod bracket with (2) screw holes on left side of hearth pan. Attach damper rod bracket to the underside of hearth pan with (2) 10 x 1/2" provided screws (See Figure 3).

***Attention:** Damper rod bracket is already installed to underside of hearth pan.

4. Two cover plates are provided in kit. Use cover plate that measures 6 3/8" in height. Do not use cover plate that measures 7" in height. Discard 7" cover plate.
5. Insert and position 6 3/8" cover plate into left, interior bottom of fireplace. The 3/8" diameter hole in cover plate will be positioned upward and to the left.

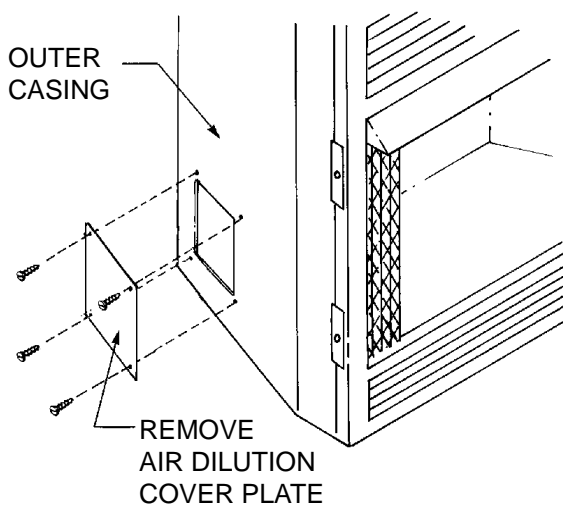

Figure 2 Damper Assembly Location

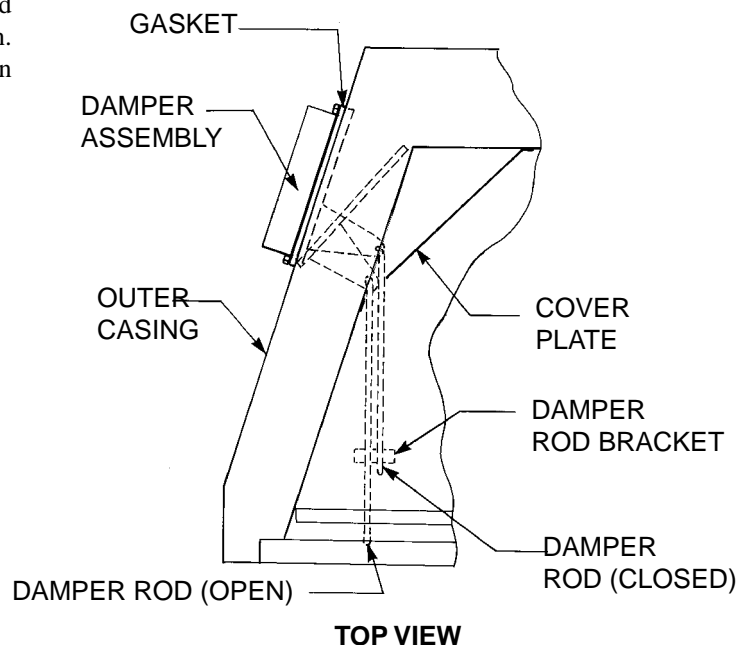

Figure 3 Top View of Air System Installation

6. Insert damper rod through damper rod bracket and 3/8" diameter hole in cover plate. Insert damper rod into 1/4" diameter hole in damper door tab. Place smooth side of 1/2" diameter pushnut over end of damper rod. Press the pushnut onto the damper rod approximately 1/8". The pushnut will prevent the damper rod from falling out of 1/4" diameter hole in damper door tab.
7. Attach cover plate to support legs with (4) 10 x 1/2" provided screws. The support legs are on the left side, to the rear, in the interior bottom of fireplace.
8. The 1 1/4" offset on damper rod is used to secure the damper door in an open or closed position.
9. Refer to Figure 4 for options available for installation of 6" diameter duct. The duct run can be a maximum length of 40 feet. Insulated duct is recommended when ducting through a heated space. Note: 6" C vent or 6" flex vent can be used.

10. Cut a 6" diameter hole in structure after determining duct termination (rain cap) location.
11. Caulk exterior of structure that will be contacted by outside air tube assembly (See Figure 5).
12. Insert outside air tube assembly into 6" diameter hole in structure. Align clearance holes on rain cap with clearance holes on outside air tube assembly. Attach rain cap and outside air tube assembly to structure with (6) 1 1/2" provided screws.
13. Attach 6" diameter duct to 1 1/2" collar on damper assembly.
14. Route 6" diameter duct to outside air tube assembly.
15. Attach 6" diameter duct to outside air tube assembly.
16. Installation of fresh air intake kit is completed.

PARTS LIST

Part Description	Part Number	Quantity Supplied
Damper Assembly	10098	1
6 3/8" Cover Plate (30")	11679	1
6 3/8" Cover Plate (36" & 42")	10083	1
Rain Cap	10124	1
Damper Rod 30"	R-6157	1
Damper Rod 36" & 42"	R-4182	1
Pushnut	R-4607	1
10 x 1/2" Screw	R-2737	6
10 x 1 1/2" Screw	R-1134	6

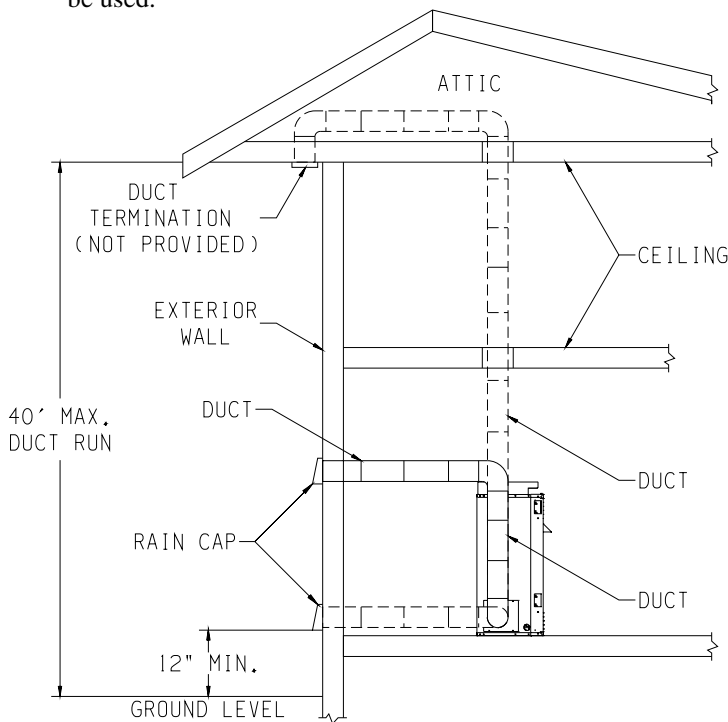

Figure 4 Example of Installation

CAULKING

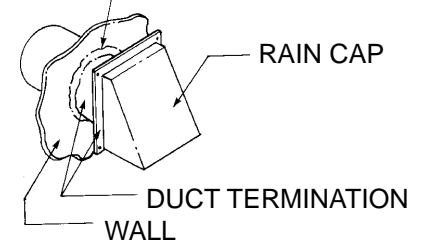

Figure 5 Caulk and Install Duct Termination

NO ELBOWS USED ON FRESH AIR KIT

WHEN 90° OR 45° ELBOWS ARE USED ON FRESH AIR KIT

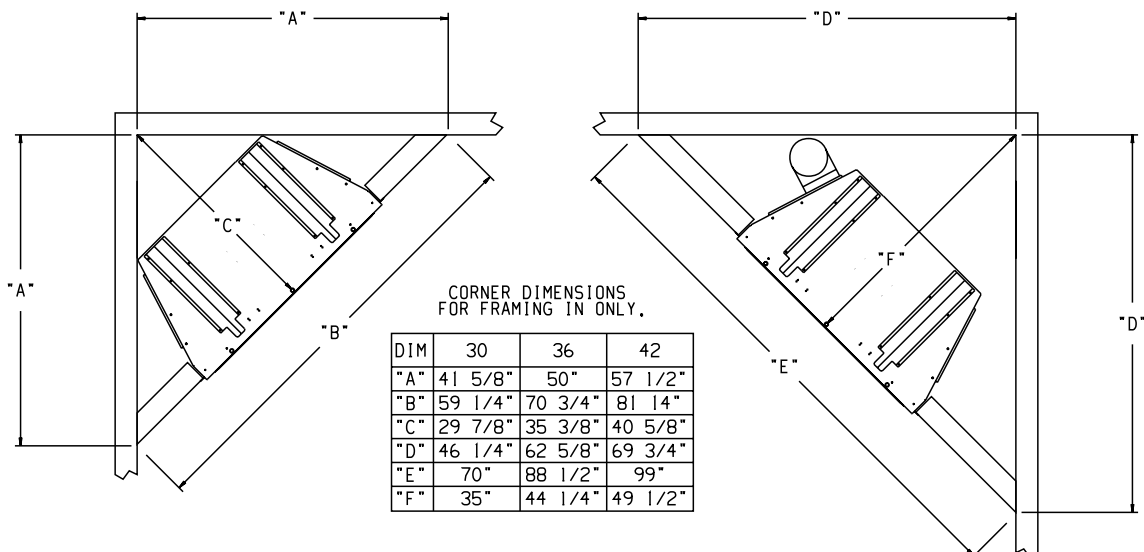

Figure 6

OPTIONAL BRICK LINER INSTALLATION INSTRUCTIONS

BRICK LINER KIT

DVS-BL-30-2, DVS- BL-36-2, DVS-BL-42-2

DVP1A-30-1, DVP1A-36-1, DVP1A-42-1

INSTALLING OPTIONAL BRICK LINER

1. If installed, turn OFF gas supply to fireplace.
2. If installed, remove logs from fireplace.
3. The back panel is to be installed before the side panels. Place back panel against the rear wall in fireplace.
4. Remove combustion dome diverter from interior, top of firebox by removing three (3) 10 x 1/2" screws.
5. Place one side panel against the side wall in fireplace. Align the brick pattern on back panel and side panel.
6. To install the brick panel (Z) bracket you must first remove the top and bottom screw on the side of the inner casing front as it attaches to the outer casing. Now, place the brick panel (Z) bracket over the front edge of the side panel. The clearance holes on the brick panel (Z) bracket will align with the top and bottom screw holes on the side of the inner casing front. Reattach the top and bottom screws through the clearance holes on the brick panel (Z) bracket and into the inner casing front.

7. Repeat Step 5 and Step 6 to attach the second side panel to fireplace.
8. Attach combustion dome diverter into interior, top of firebox with three (3) 10 x 1/2" screws from Step 4.
9. Installation of optional simulated brick panels is completed

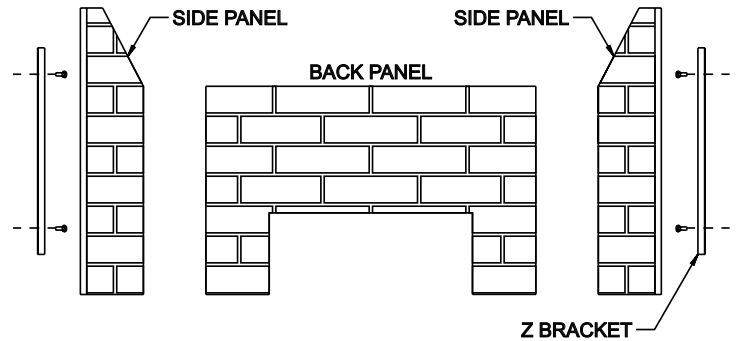

PARTS LIST

Part Description	Kit Number DVS-BL-30-2	Kit Number DVS-BL-36-2	Kit Number DVS-BL-42-2	Quantity Supplied
Brick Panel (Z) Bracket	11573	10990	10991	2
Brick Panel - Right	R-6505	R-6508	R-6511	1
Brick Panel - Left	R-6503	R-6506	R-6509	1
Brick Panel - Back	R-6504	R-6507	R-6510	1

Part Description	Kit Number DVP1A-30-1	Kit Number DVP1A-36-1	Kit Number DVP1A-42-1	Quantity Supplied
Brick Panel (Z) Bracket	11573	10990	10991	2
Brick Panel - Right	R-6546	R-6549	R-6558	1
Brick Panel - Left	R-6545	R-6548	R-6557	1
Brick Panel - Back	R-6544	R-6547	R-6556	1



Empire Comfort Systems, Inc.
 Nine Eighteen Freeburg Ave.
 Belleville, Illinois 62220-2623

PH: 1-800-851-3153
 FAX: 1-800-443-8648
 E-MAIL: info@empirecomfort.com
 WEB SITE: www.empirecomfort.com