

ASSEMBLY/ ARMADO

NOTE: DO NOT over tighten screws and washers that come into contact with porcelain coated surfaces. Over tightening may cause the porcelain coating to crack and break, resulting in exposed metal that will be prone to rust.

Nota: NO apriete demasiado los tornillos y arandelas que entren en contacto con las superficies revestidas de porcelana. Si los aprieta demasiado, se puede quebrar y romper el revestimiento de porcelana lo que dejará expuesto el metal al proceso de oxidación.

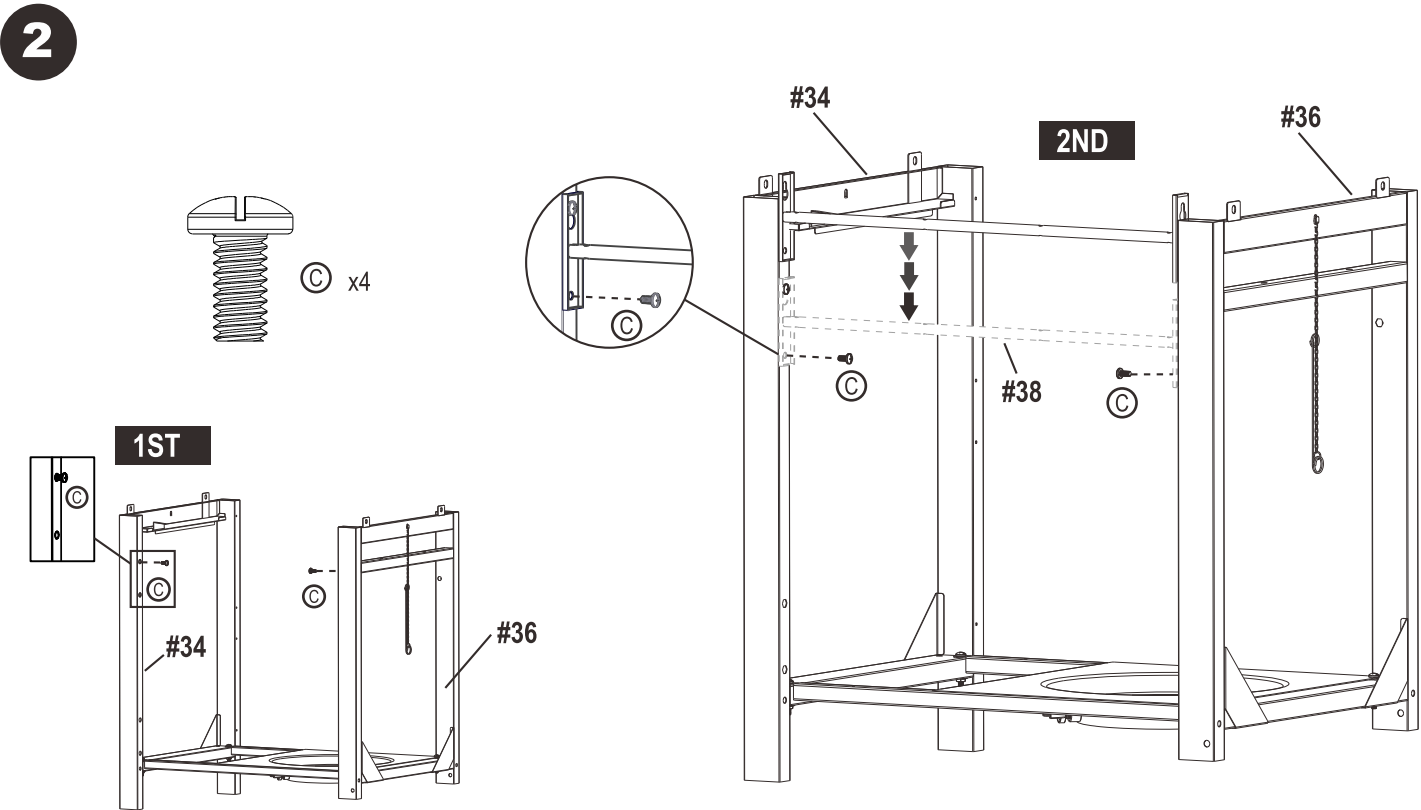
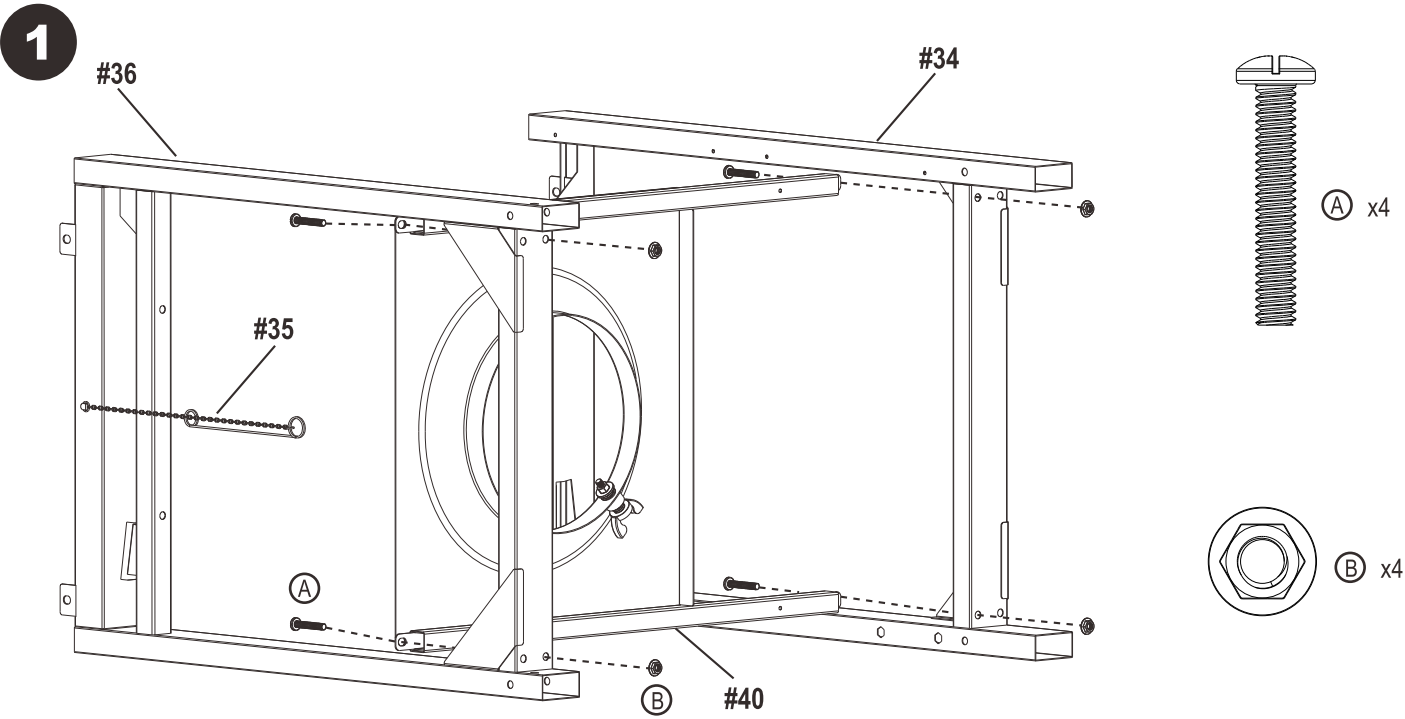

3

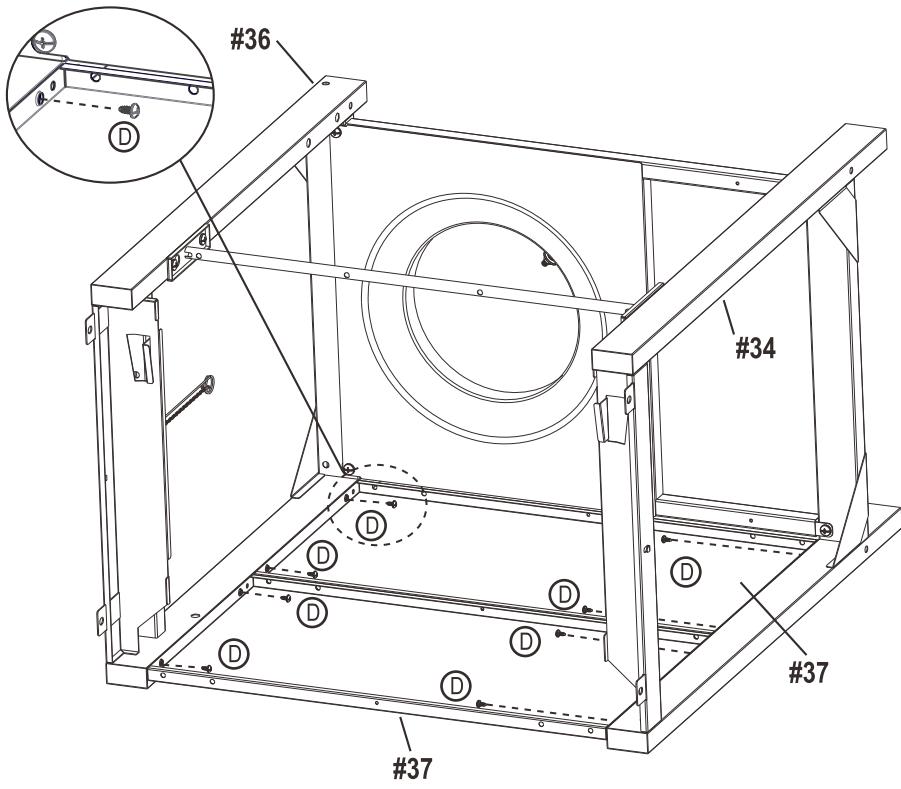

4

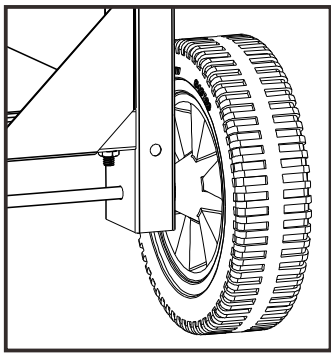
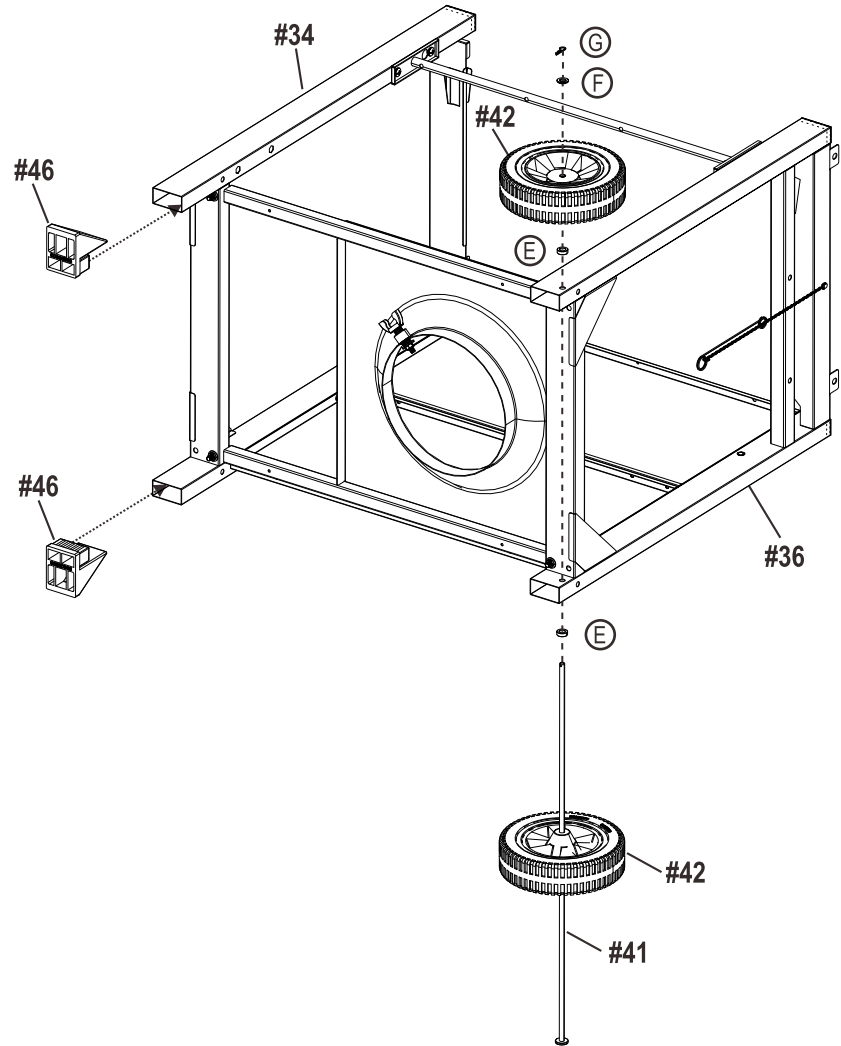
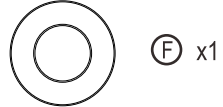

5

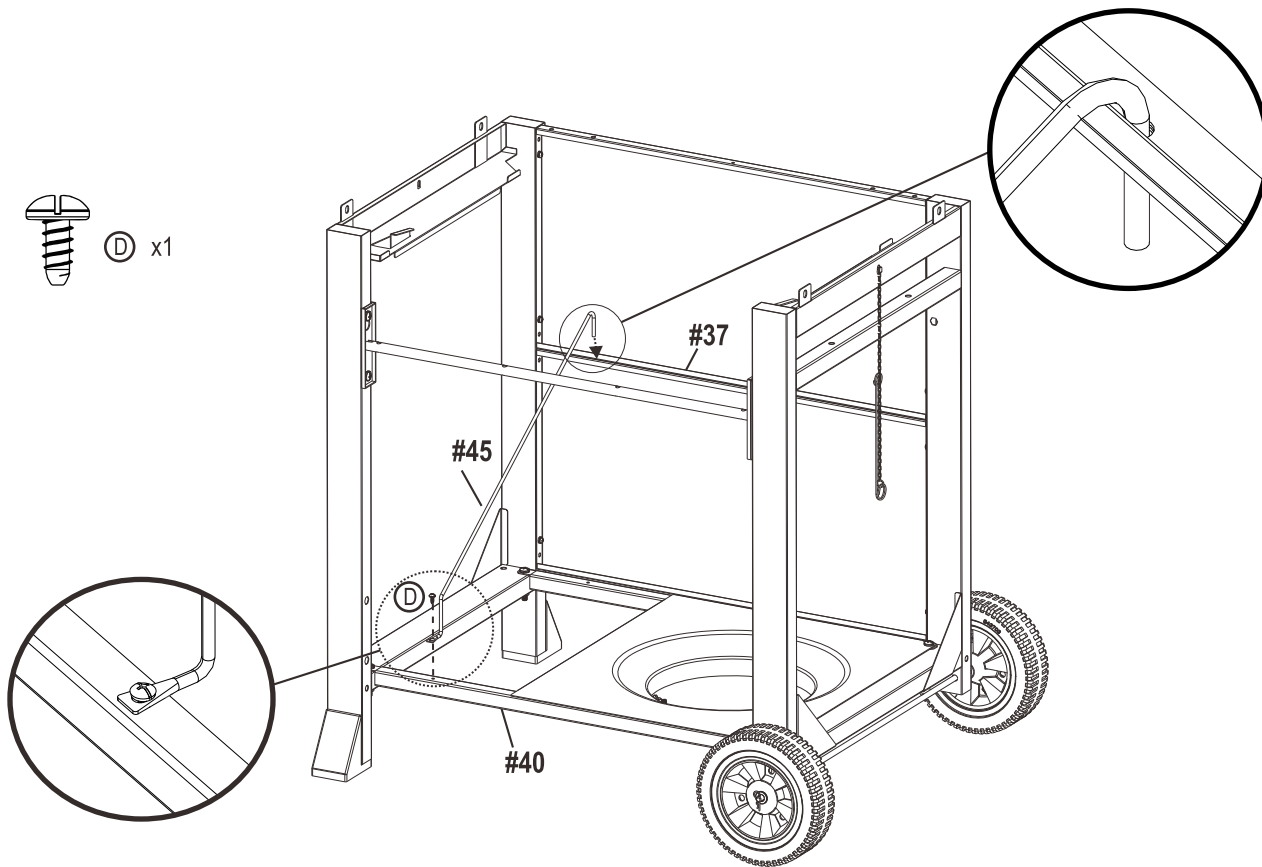

6

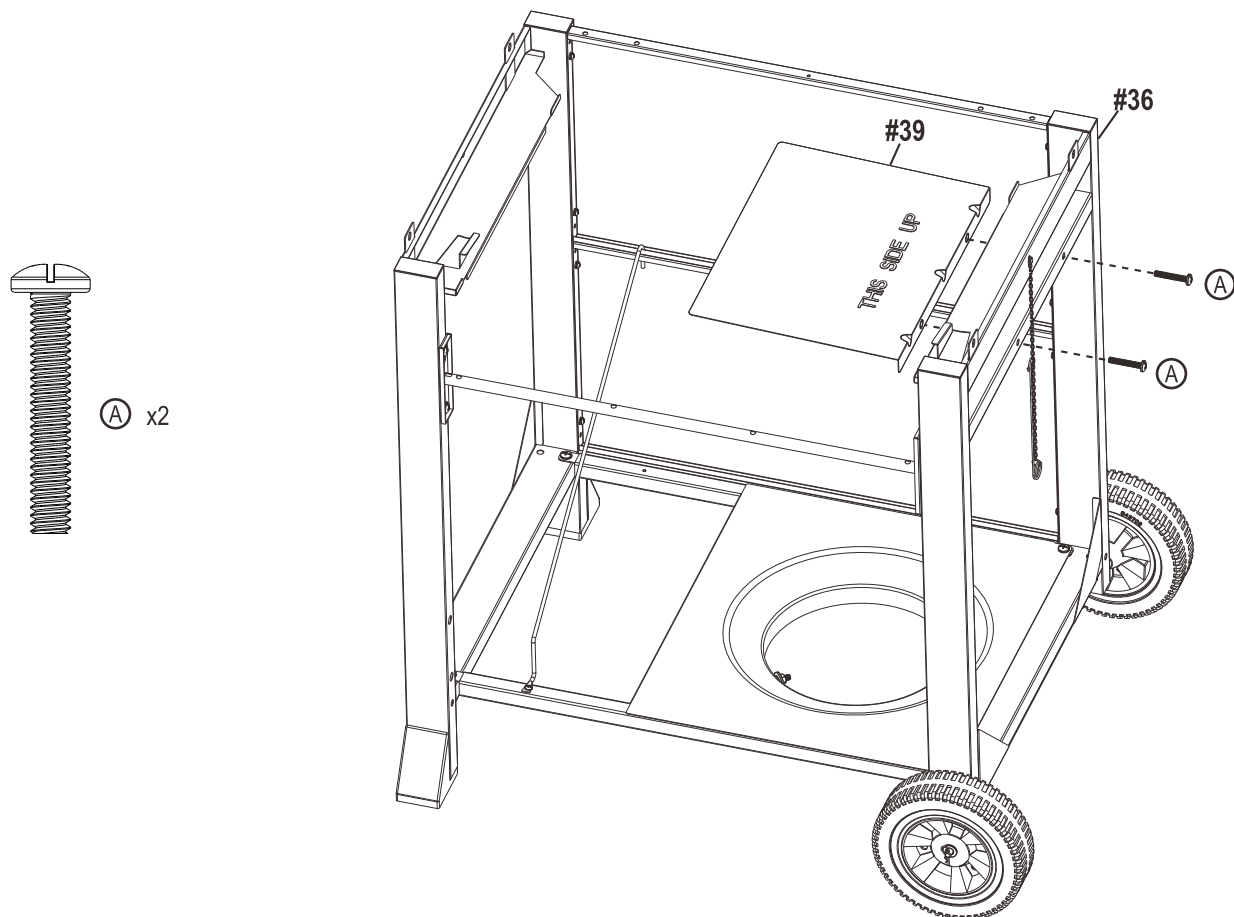

7

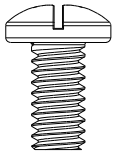
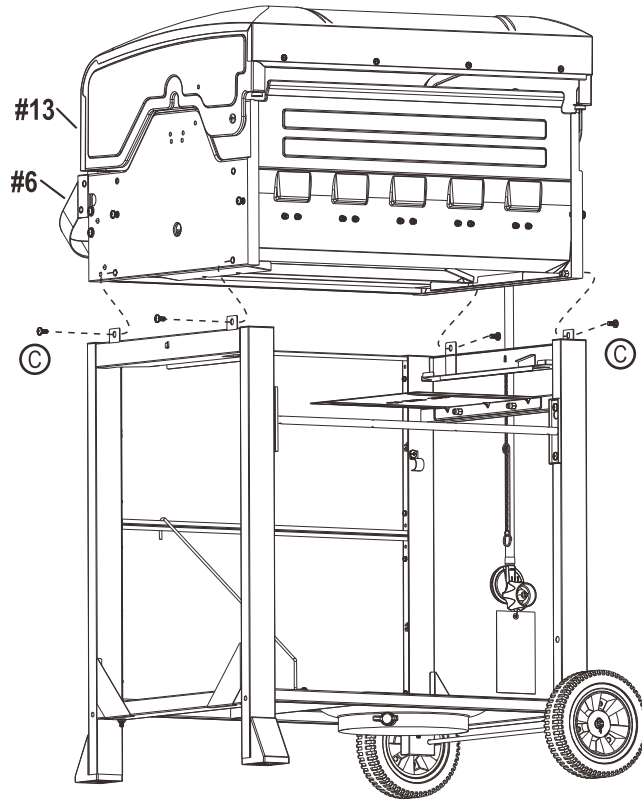
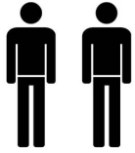

C x4

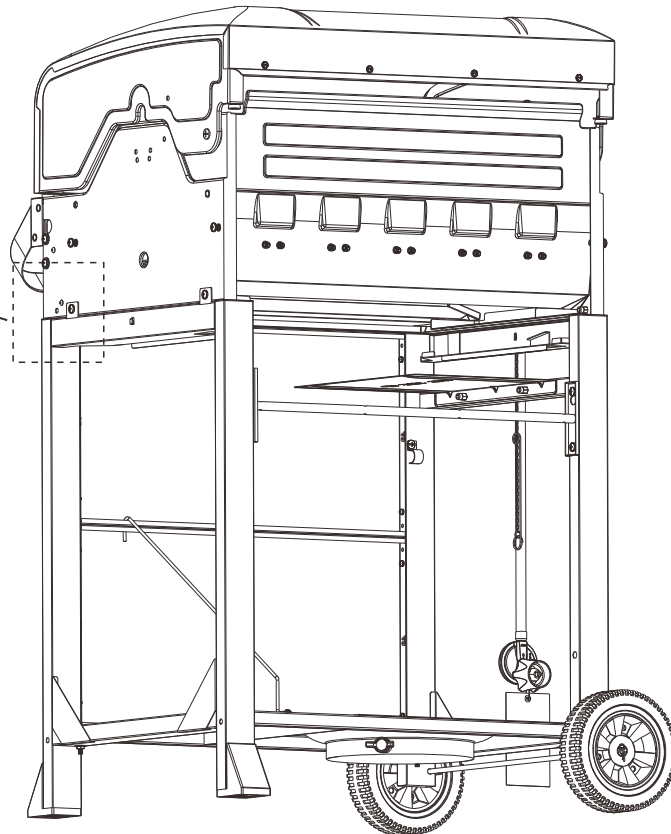
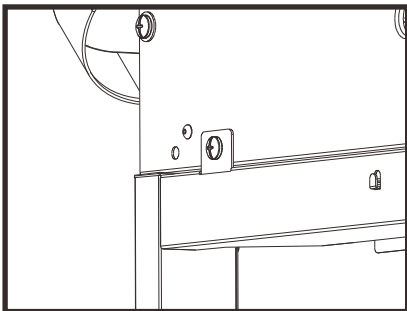

8

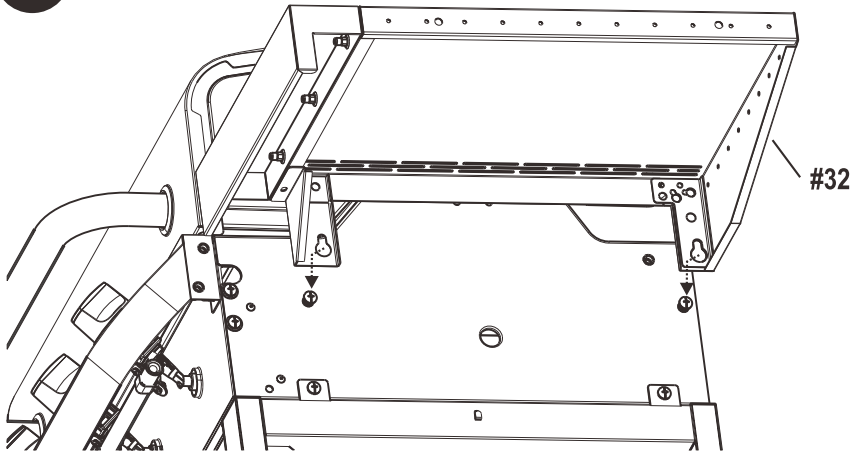

1ST

#32

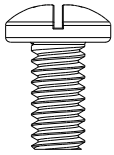

C x4

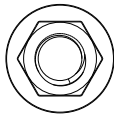

B x1

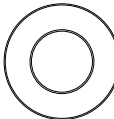

H x1

2ND

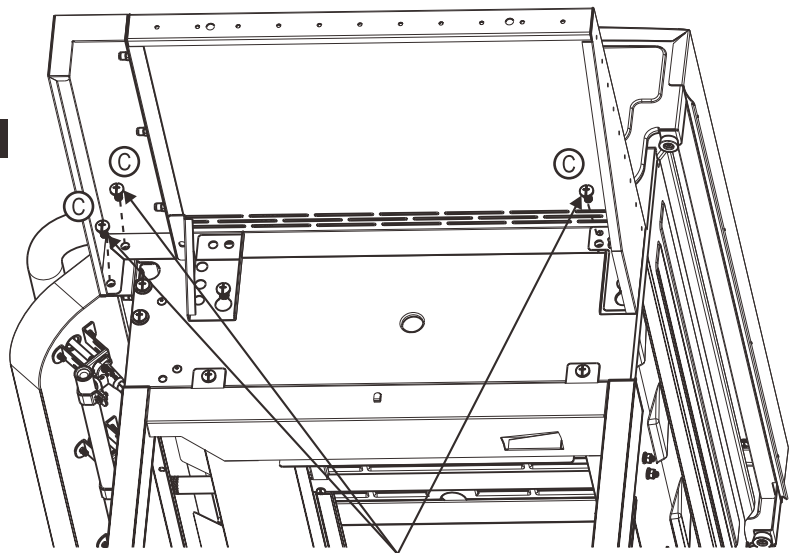

Do not tighten the screws
No apriete los tornillos

3RD

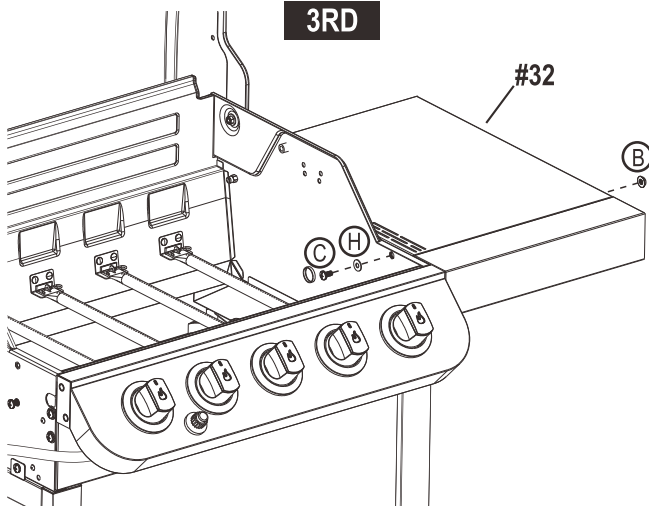

#32

B

C

H

4TH

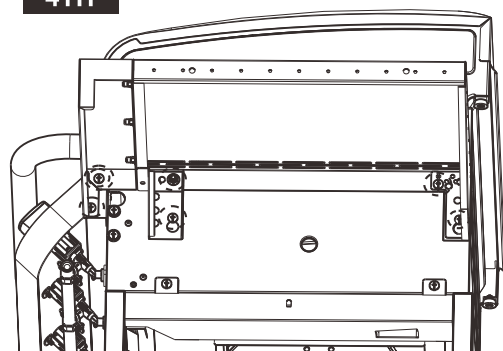

Tighten the screws
Apriete los tornillos

9

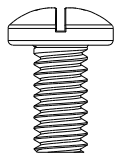
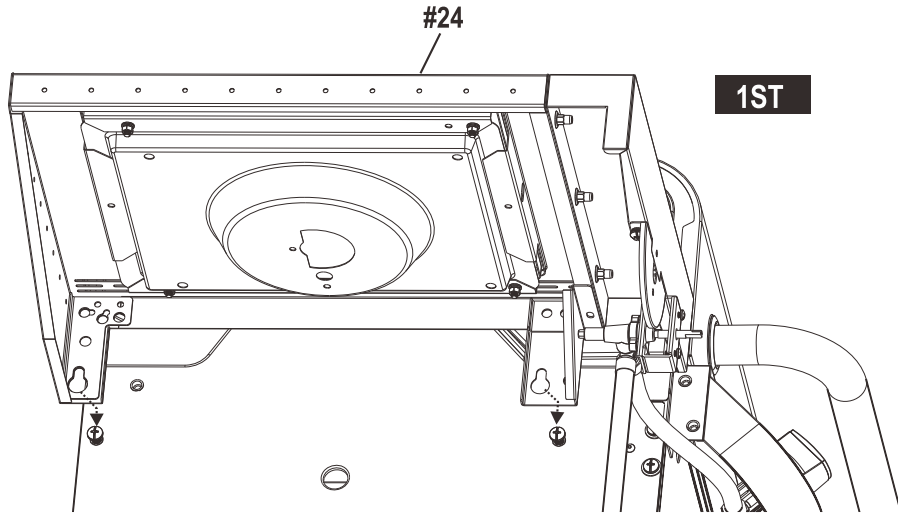

C x4

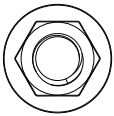

B x1

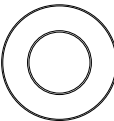

H x1

2ND

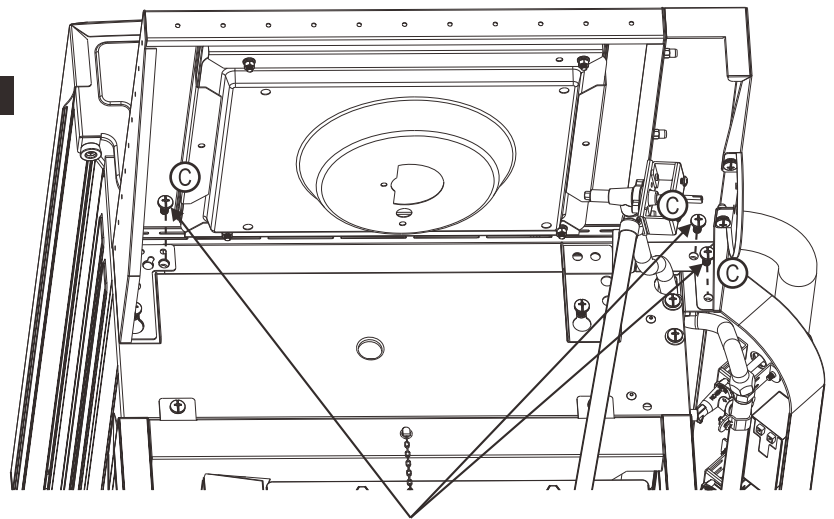

Do not tighten the screws
No apriete los tornillos

3RD

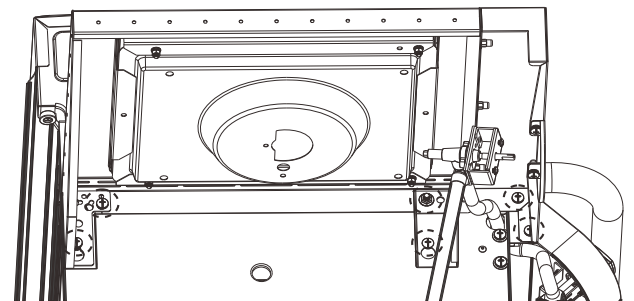
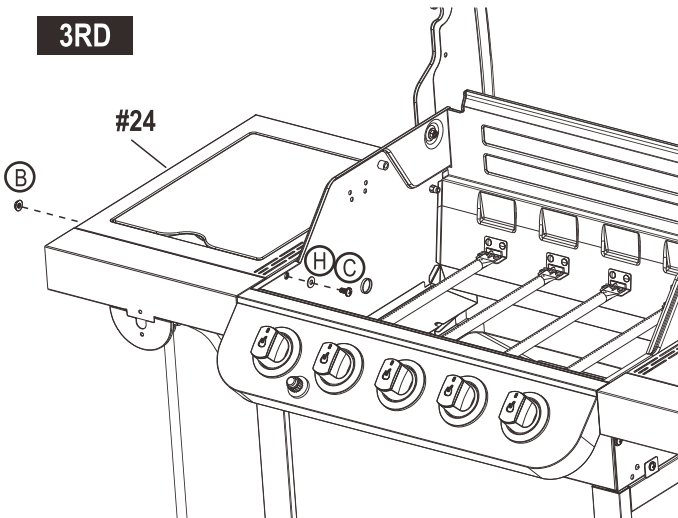

Tighten the screws
Apriete los tornillos

4TH

10

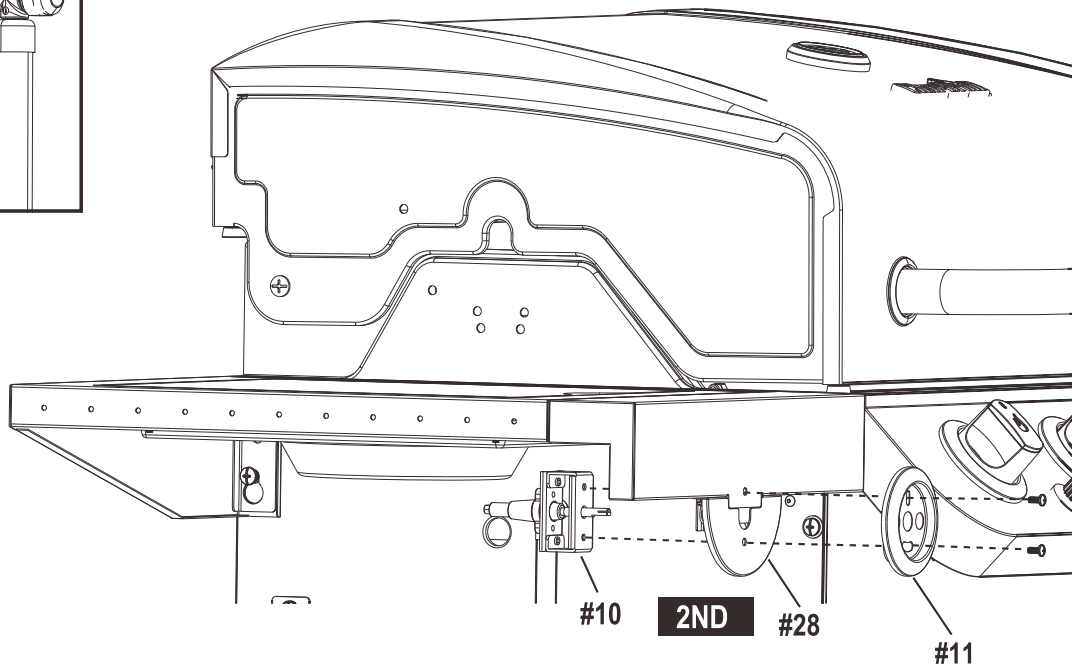
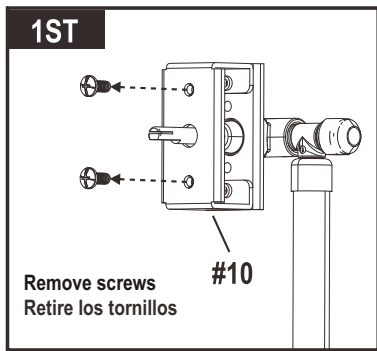

Secure using screws that were removed from sideburner valve bracket.
Fijelo con los tornillos que retiró del soporte de la válvula del quemador lateral.

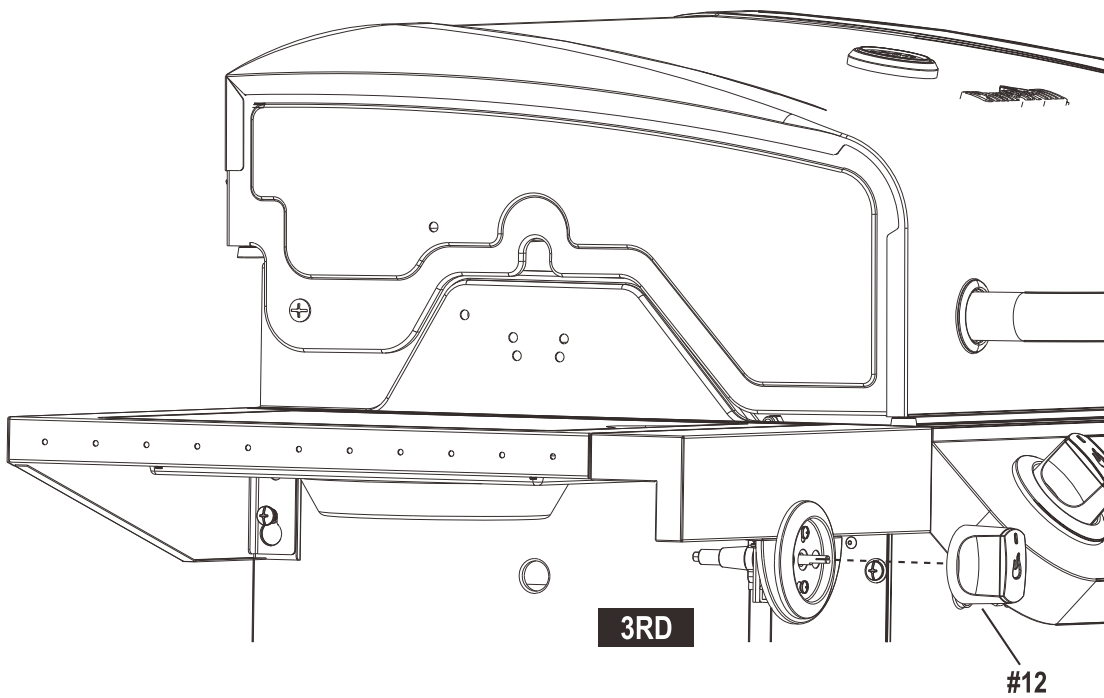

11

1ST

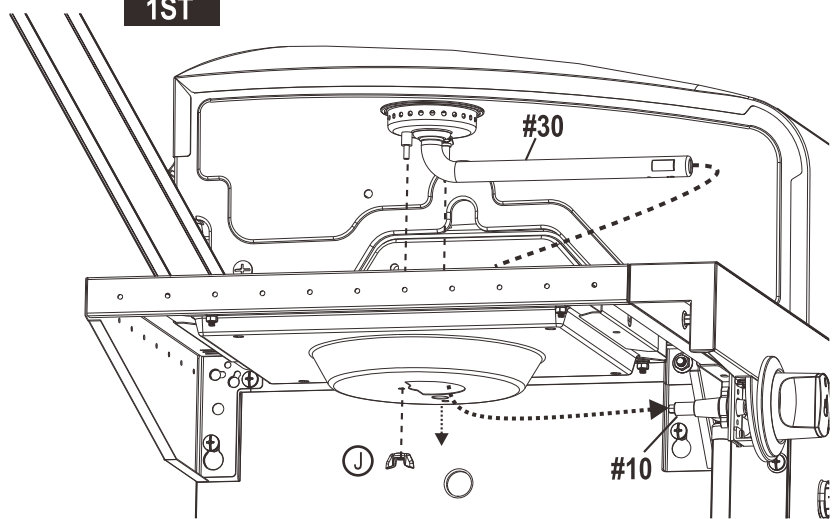

2ND

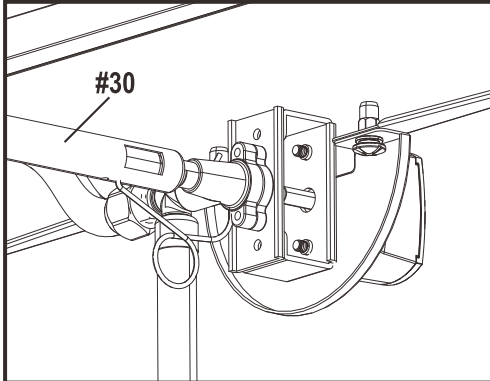
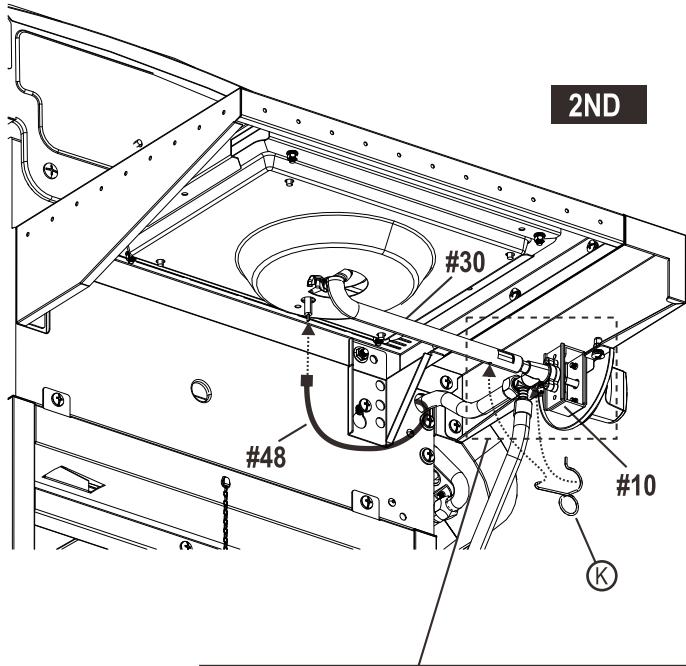

3RD

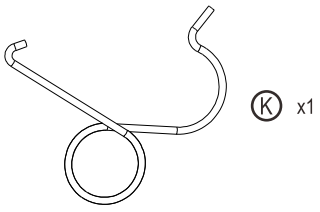
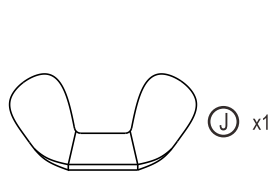
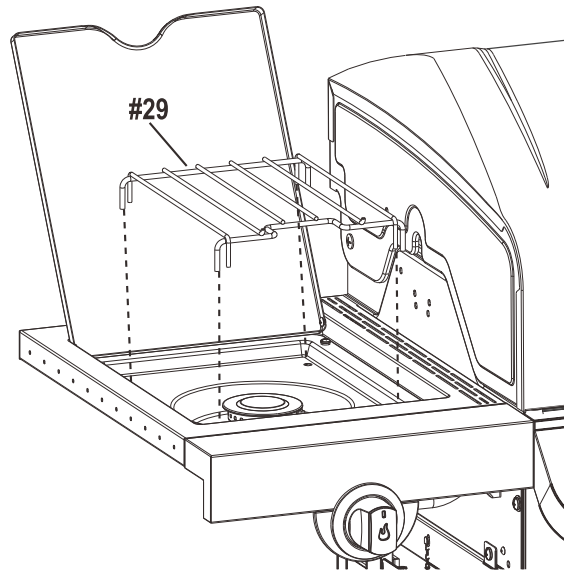

12

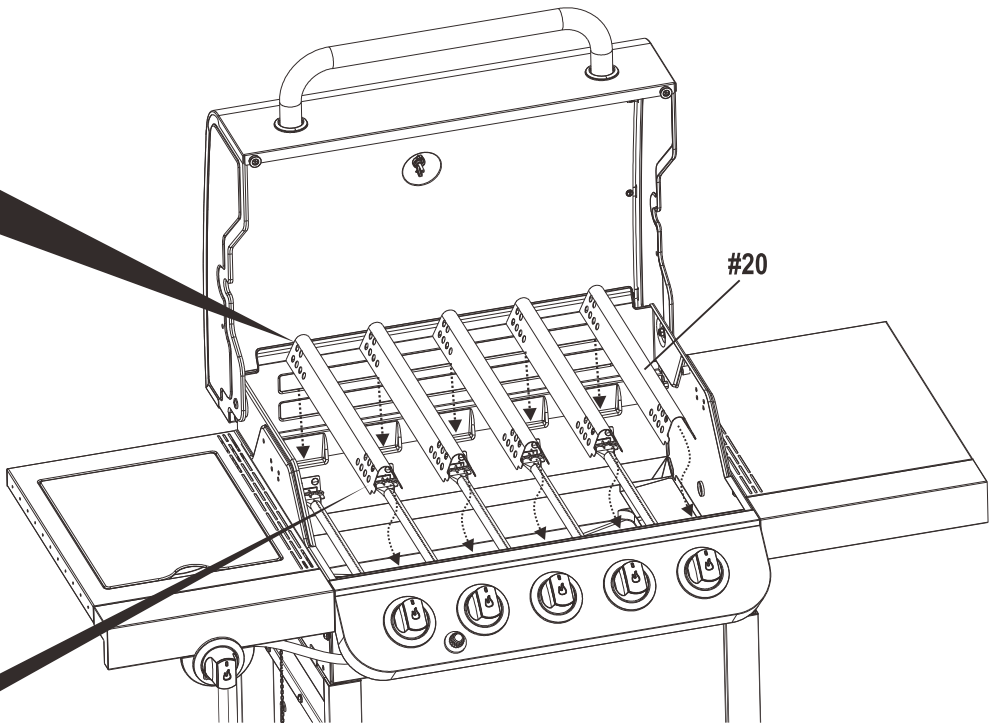
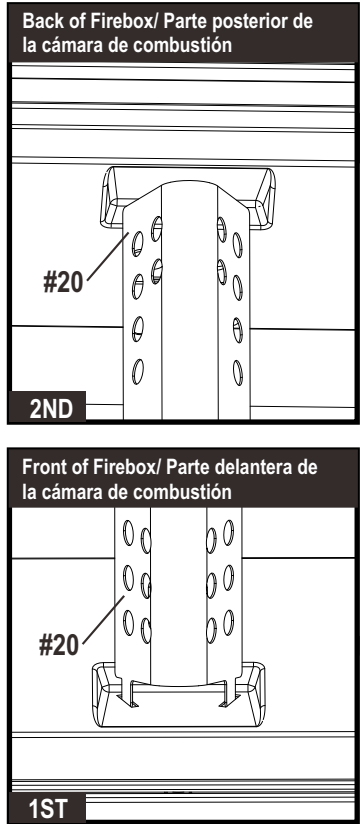

13

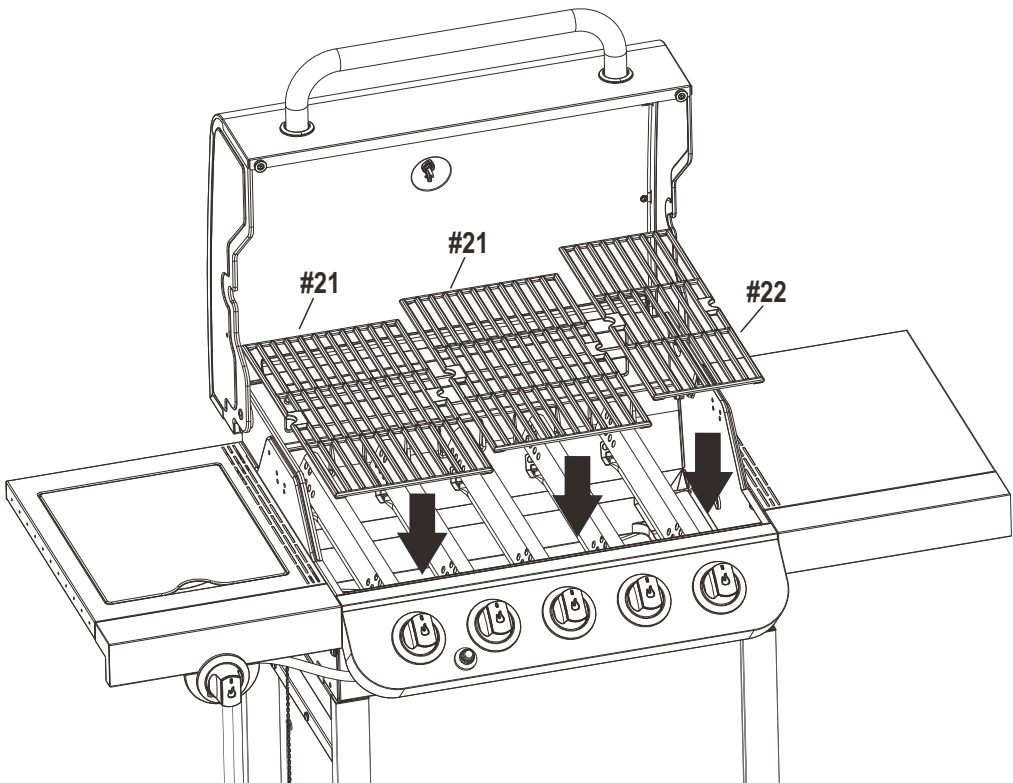

14

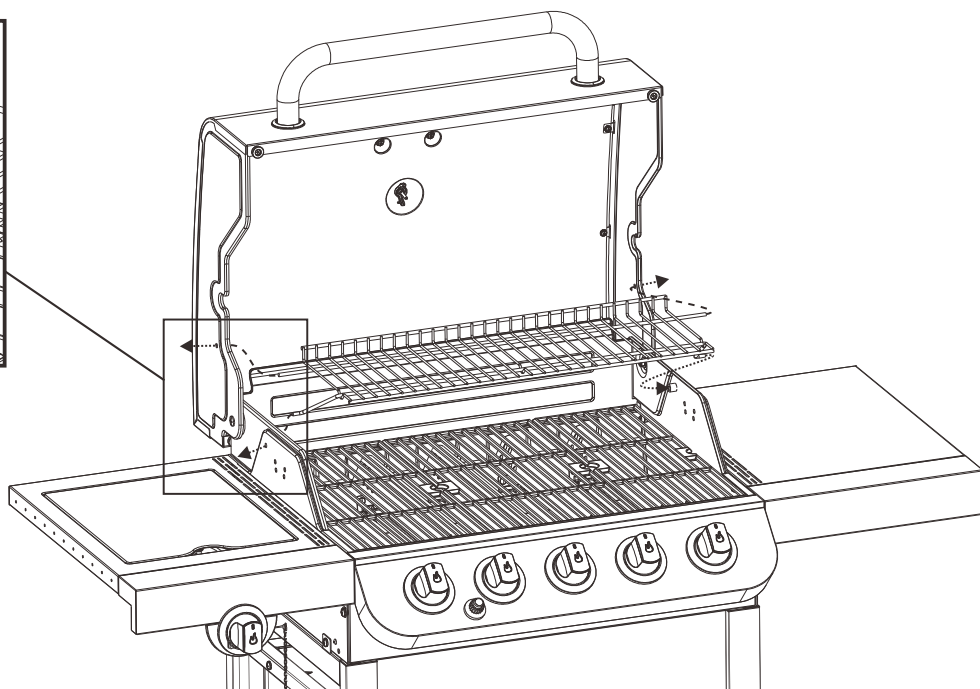
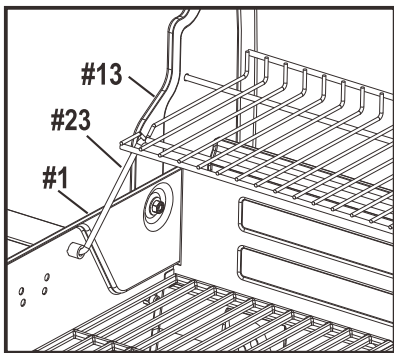

15

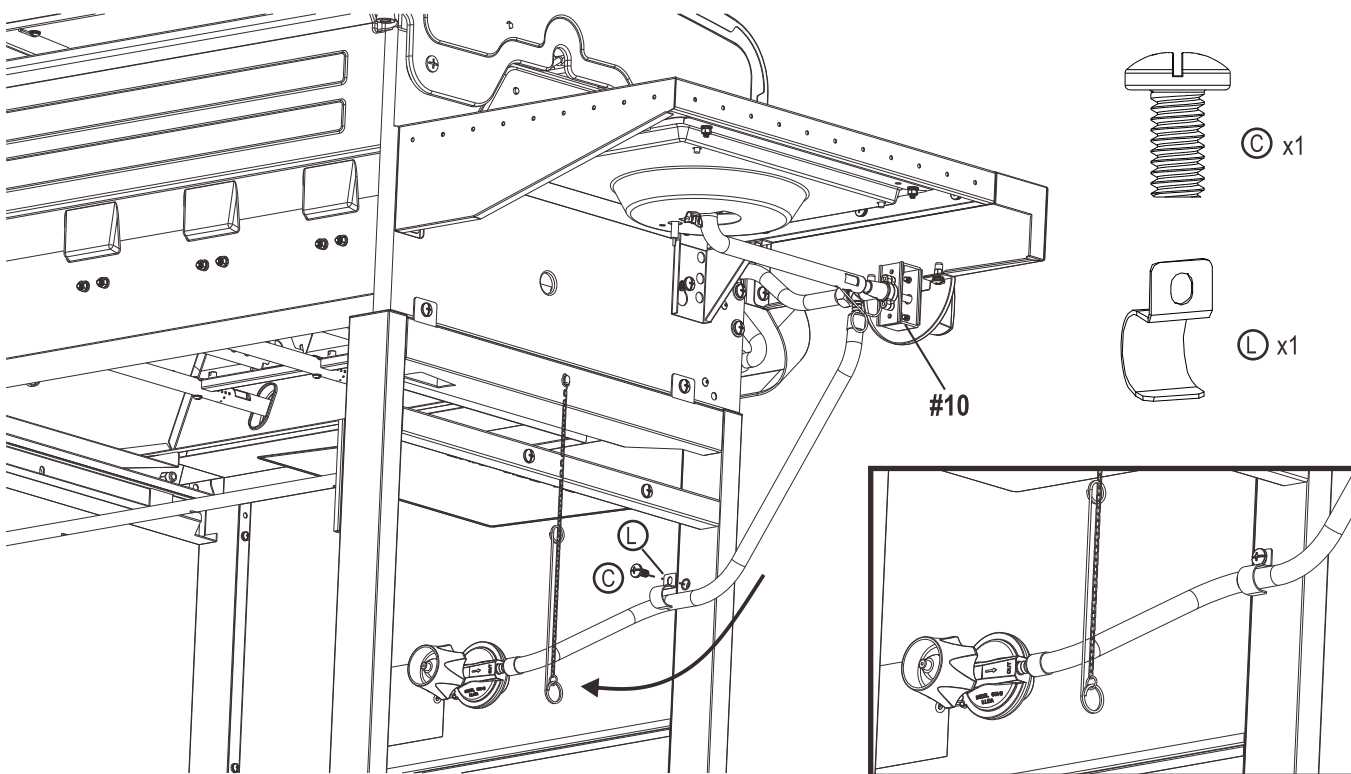

CAUTION

Failure to route the hose through the hose clip may allow the gas hose to be damaged in operation, resulting in the risk of fire.



ADVERTENCIA

No enrutar la manguera a través del sujetador podría permitir que la manguera de gas se dañe durante el funcionamiento, ocasionando un riesgo de incendio.

16

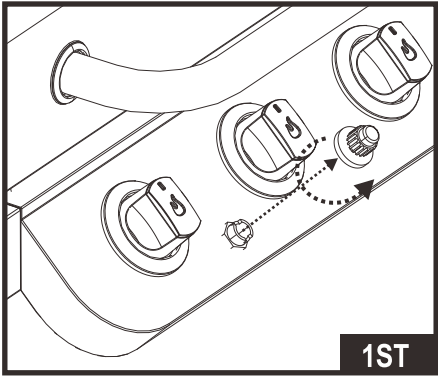

2ND

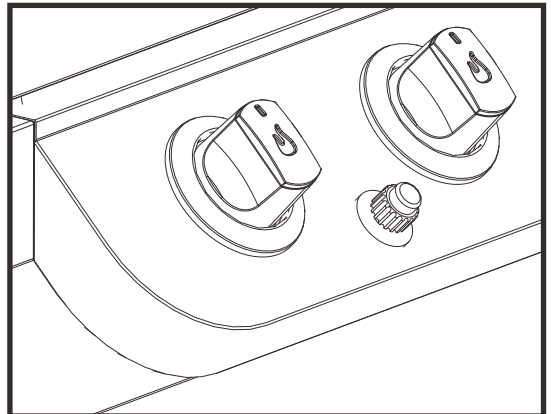
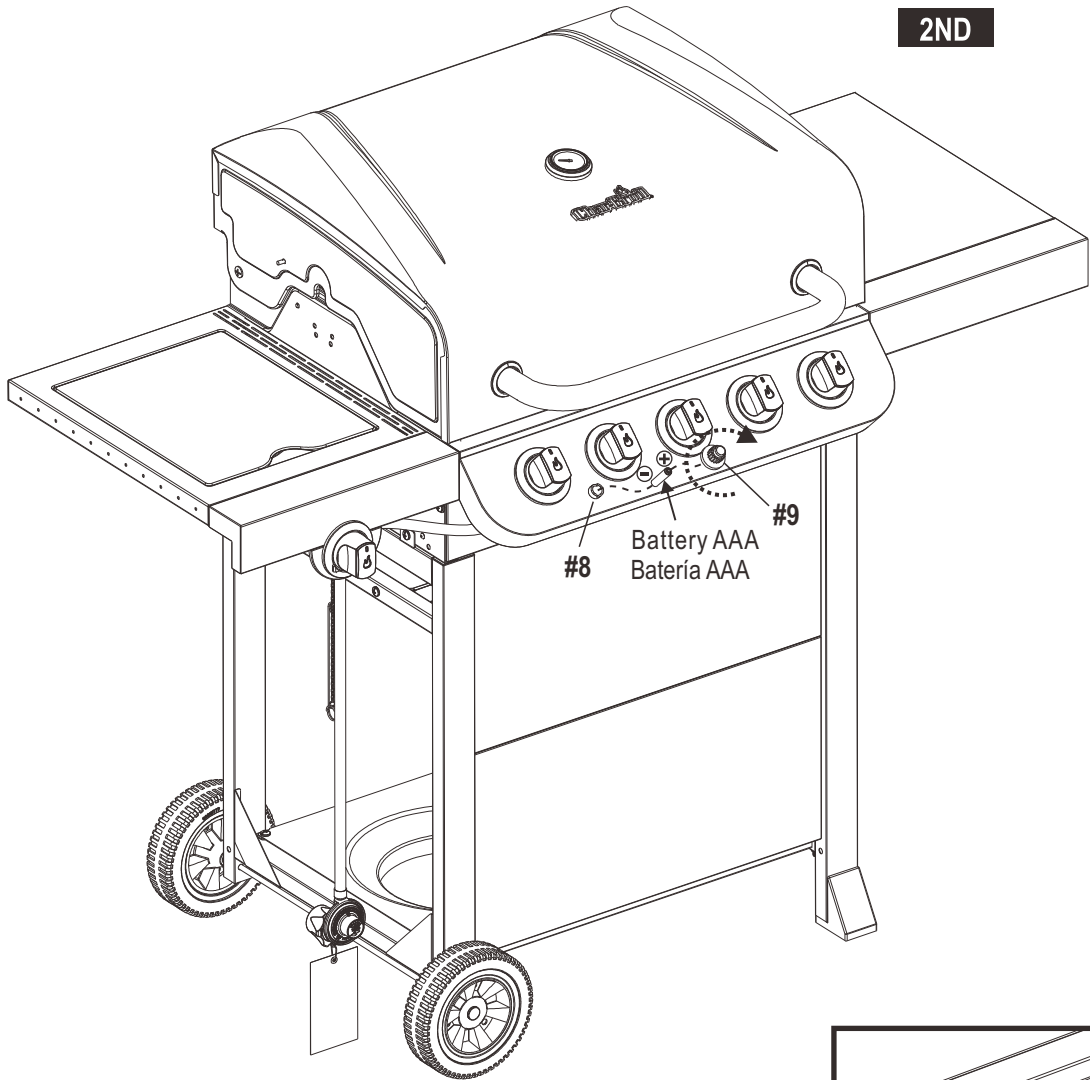

1ST

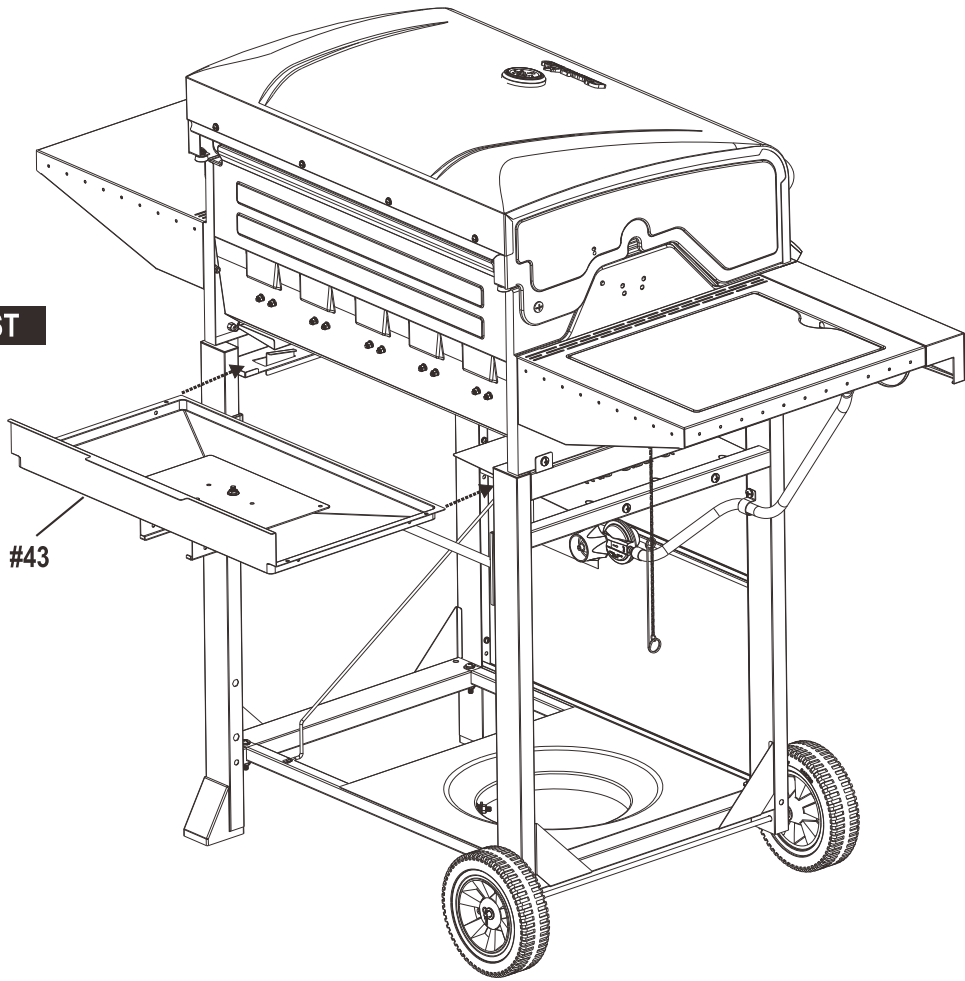

2ND

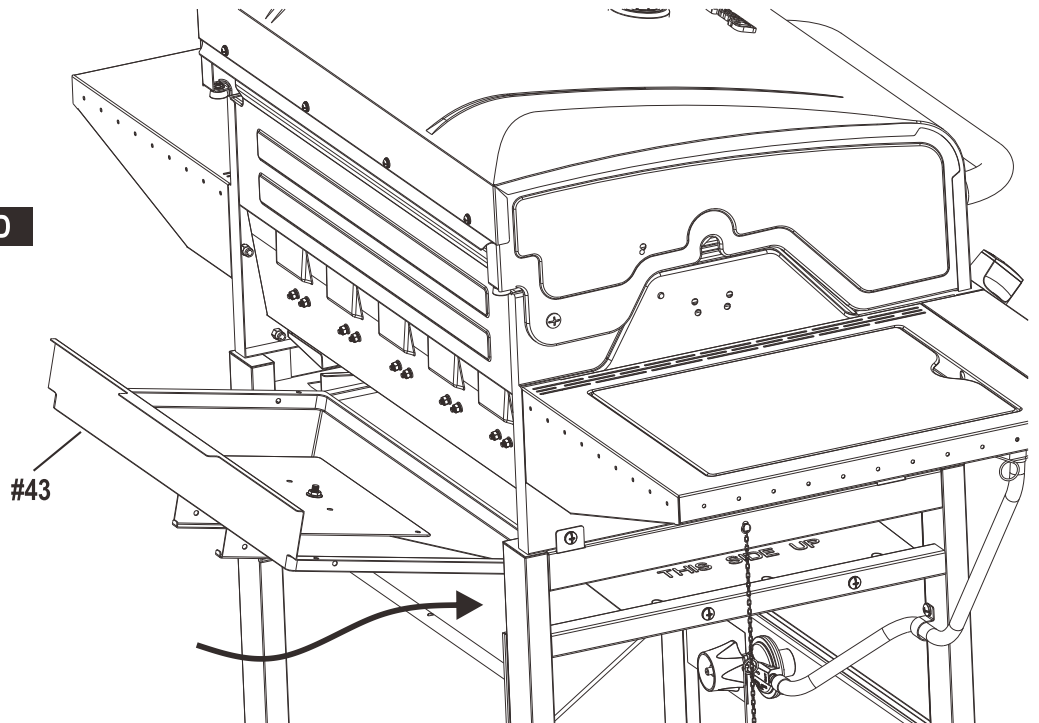

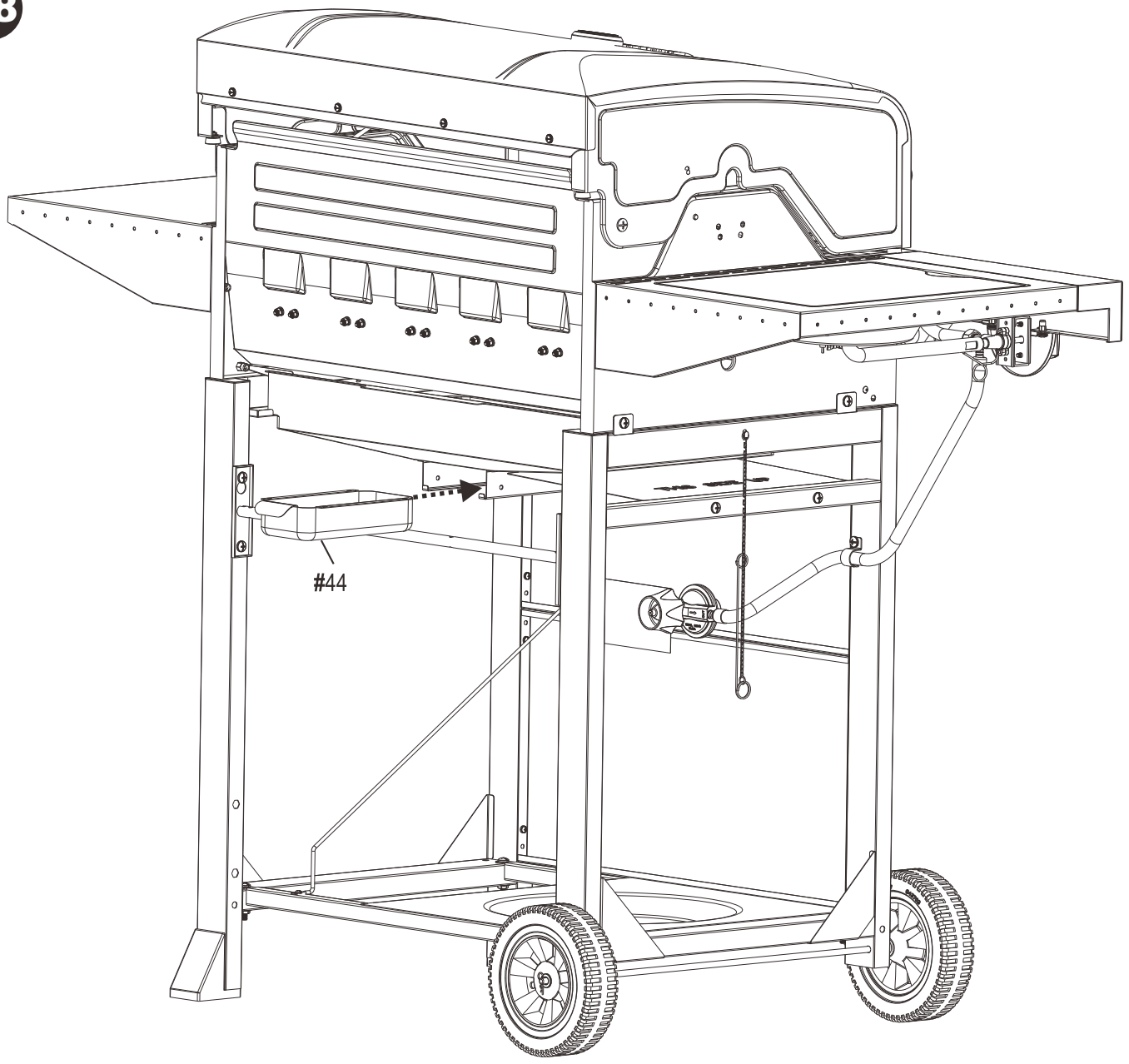

	CAUTION	
<p>Failure to install grease tray and grease pan will cause hot grease to drip from bottom of grill with risk of fire or property damage.</p>		

	ADVERTENCIA	
<p>El no instalar la bandeja y el recipiente para la grasa ocasionará el goteo de grasa caliente desde la parte inferior de la parrilla, lo que presenta el riesgo de incendio o daños materiales.</p>		

19

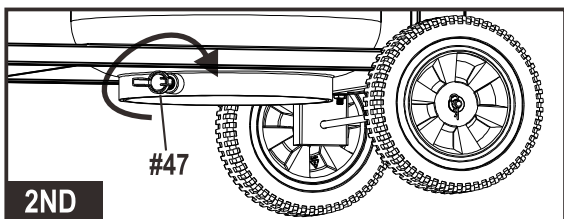
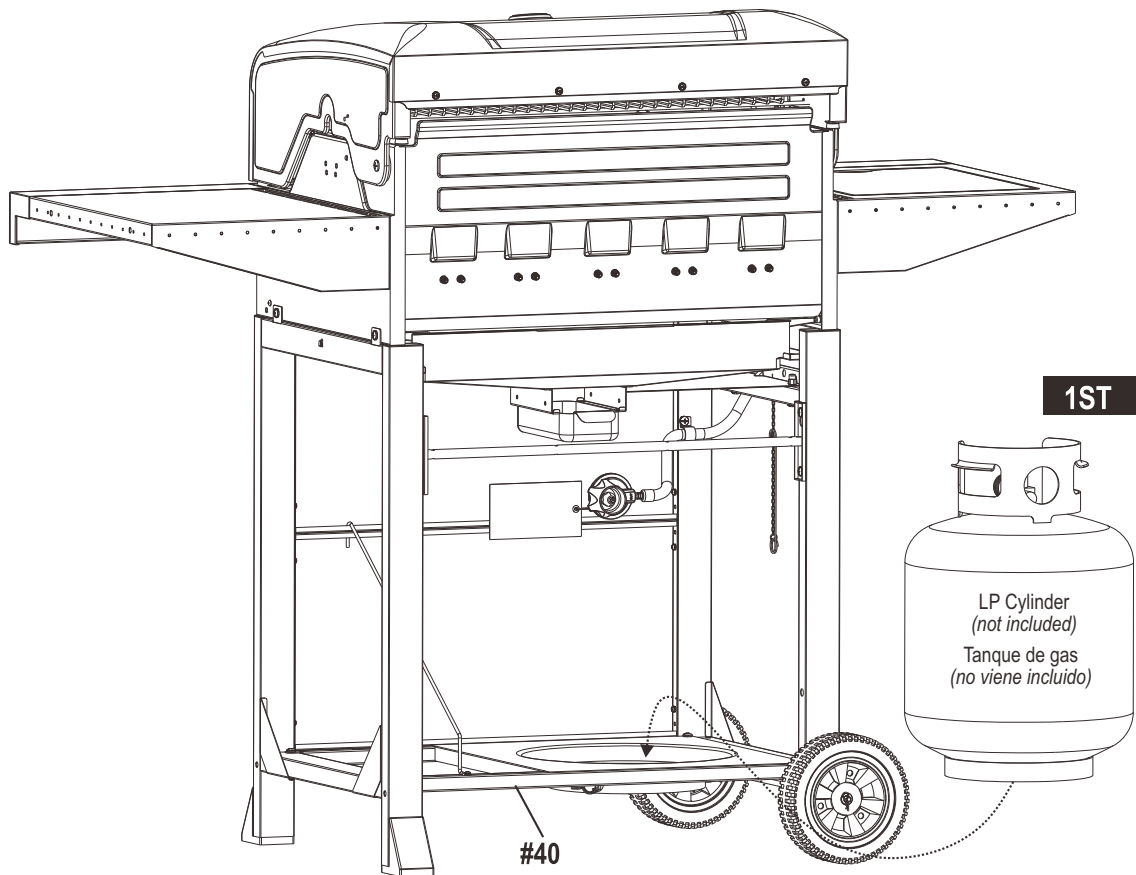

2ND

CAUTION

Cylinder valve must face to front of cart once tank is attached. Failure to install cylinder correctly may allow gas hose to be damaged in operation, resulting in the risk of fire.

ADVERTENCIA

Una vez que el tanque haya quedado instalado, la válvula del tanque debe quedar orientada hacia la parte delantera del carrito. Si no se instala correctamente el tanque, se puede dañar la manguera de gas durante el suministro, lo que puede ocasionar el riesgo de incendio.

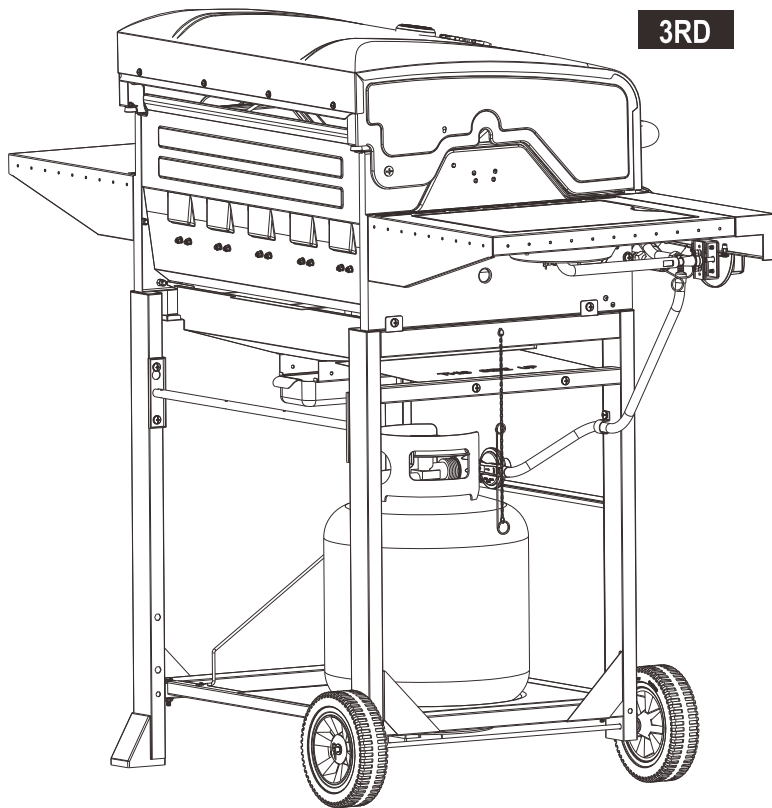

GRILLING GUIDE – Getting Started

First Time Use

Read your Assembly Manual and ensure the grill is put together properly. Remove all Point-of-Purchase advertising material from all grill surfaces before first use. We recommend operating your grill on its highest setting for 15-20 minutes prior to your first use. This aids in removing the oils used during manufacturing.

Lava Rock / Briquettes

This gas grill has been designed, engineered, and tested to be used with heat tents to provide more even heating, improve the cleaning process, and reduce flare-ups. The addition of after market lava rocks, charcoal, or briquettes of any type will cause poor combustion and increase the likelihood of a grease fire, and is not recommended. Using briquettes, lava rock, or charcoal in this grill will void your warranty. For extra smoke flavor, we recommend using a smoker box with wood chips.



Temperature

The temperature gauge in the hood of your new grill measures air temperature. The air temperature inside your grill will never be as hot as the temperature at the cooking surface. This gauge is calibrated to give a close indication of the grate temperature.

Note: Since 1995, all regulators (the part that attaches to the gas tank to regulate the flow of gas) have included a safety feature that restricts gas flow in the event of a gas leak. You can inadvertently activate this safety feature without having a gas leak. This typically occurs when you turn on the gas using the grill control knob before you turn on the LP tank valve. If the gas regulator safety feature activates, the grill will only reach temperatures between 250°F and 300°F even with all burners on the high setting.

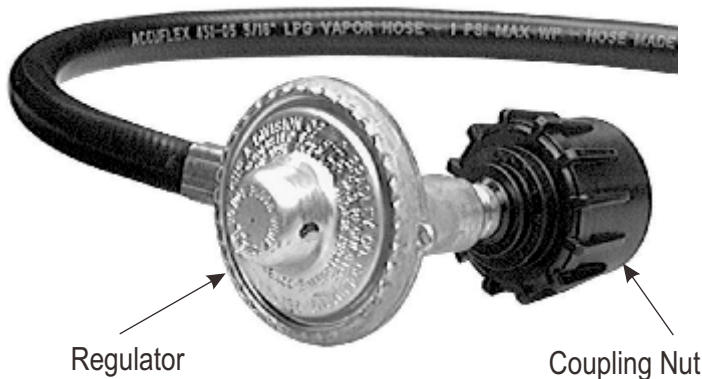

If your grill is not getting hotter than 250°F to 300°F these steps should be taken first to reset the gas regulator safety device:

1. Open the grill lid.
2. Turn off all knobs on the control panel in front.
3. Turn off the tank knob.
4. Disconnect the regulator from the LP tank.
5. Wait 30 seconds.
6. Reconnect the regulator to the LP tank.
7. Slowly open the LP tank knob all the way. Do not put excessive force on the valve at the full open position to avoid damaging the valve.
8. Turn on the appropriate control knob and light the grill per the instructions.

An illustration of this process is included in this Product Guide. See Troubleshooting section for additional information.

Pre-Heating Your Grill

Just like your home oven, your grill should be pre-heated to provide optimum performance. Pre-heat the grill on high for 10-15 minutes – longer if weather conditions require. Please refer to the lighting instructions inside the Product Guide if you have questions about how to light your grill. A match-light chain and hole is provided for your convenience.

Outdoor grilling is really quite simple. You'll succeed with burgers, dogs, or steaks usually on your very first try. With experience, you will learn how to work with your grill, creating more imaginative meals all the time. This knowledge makes up the art of grilling. Before you start grilling, organize your food according to cooking technique and required cooking time, and optimize the use of your grilling area.

Direct Cooking

Direct cooking involves grilling your meat directly over high heat. It is perfect for searing steaks, chops, and other smaller pieces of meat and vegetables that quickly make their way to the table.

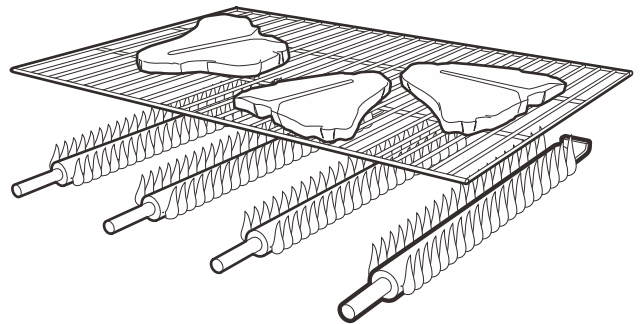

Indirect Cooking

Indirect cooking utilizes select burners to circulate heat throughout the grill, without direct contact between the meat and the flame. The meat is placed over the burner that is 'off'. This method is generally used to slow cook large cuts of meat and poultry. A pan can be placed underneath the meat to catch grease and food drippings, and helps minimize clean-up.

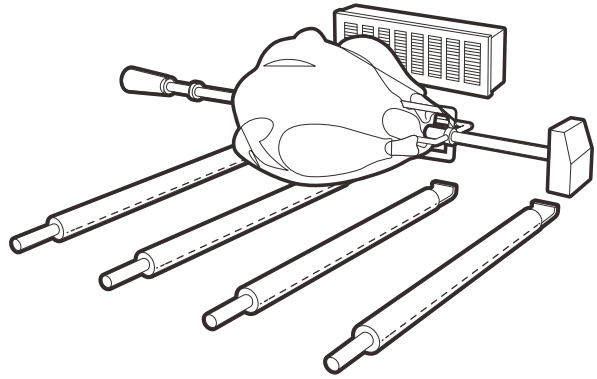

Food Safety

Food safety is a very important part of enjoying the outdoor cooking experience. To keep food safe from harmful bacteria, follow these four basic steps:

Clean: Wash hands, utensils, and surfaces with hot soapy water before and after handling raw meat.

Separate: Separate raw meats from ready-to-eat foods to avoid cross contamination. Use a clean platter and utensils when removing cooked foods.

Cook: Cook meat and poultry thoroughly to kill bacteria. Use a thermometer to ensure proper internal food temperatures.

Chill: Refrigerate prepared foods and leftovers promptly.

Cooking on your new grill is a hands-on experience, and it is recommended to remain outside with your grill while cooking. Grilling can be affected by many external conditions. In cold weather, you will need more heat to reach an ideal cooking temperature, and grilling may take longer. The meat's internal temperature and thickness can also affect cooking times. Cold and thicker meats will take longer to cook.

Internal Meat Temperatures

Meat cooked on a grill often browns very fast on the outside. Therefore, use a meat thermometer to ensure it has reached safe internal temperatures.

USDA Recommended Safe Minimum Internal Temperatures	
Beef, Veal, Lamb, Steak, Roasts, & Whole Pork (with a 3 minute rest time)	145° F
Fish	145° F
Beef, Veal, Lamb, and Pork - Ground	160° F
Egg Dishes	160° F
Turkey, Chicken & Duck Whole, Pieces & Ground	165° F

Please refer to the USDA for complete, up-to-date information. Our internal temperature chart is based on USDA standards for meat doneness. Check it out at www.isitdoneyet.gov

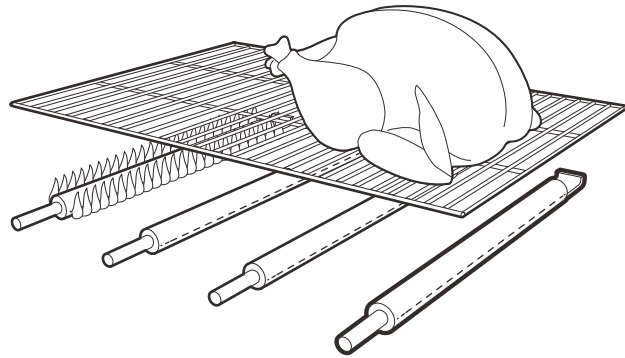
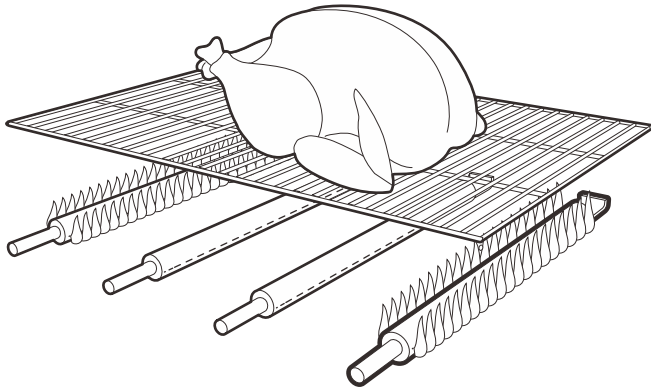

Rotisserie Cooking

Rotisserie cooking is best for 'round' meat, such as large roasts, whole poultry, and pork. It generally requires an accessory motor and spit rod that allows the meat to be turned at a constant speed. Rotisserie cooking is best done in front of a special rotisserie burner, or utilizing an indirect cooking burner arrangement. A pan can be placed underneath the meat to catch grease and food drippings, and helps minimize clean-up.

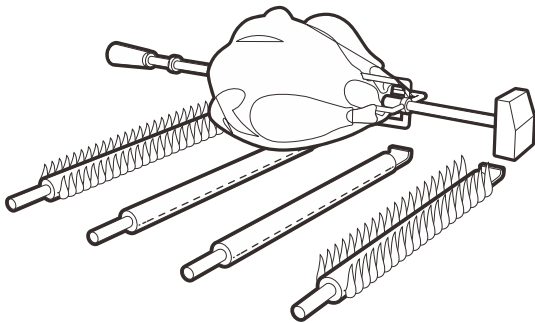

GRILLING GUIDE – Tips & Tricks

Sauces

Sauces containing sugars and fats can cause flare-ups, and your food may burn. In general, apply these sauces during the final 5 minutes of cooking. Keep in mind, use of excessive sauces or glazes will also require extra cleaning afterwards.

Marinades and Rubs

To enhance the flavor of grilled foods, a liquid marinade or dry rub can be used prior to cooking. Meat can be either soaked or injected with liquid marinade up to 24 hours prior to grilling. Dry rubs can be applied directly to the meat immediately before grilling.



Wood Chips

For extra smoke flavor when grilling, try adding wood chips. Place smoke box or pan on top of the cooking grate above the flame. Turn grill on high until the wood starts to smoke. Reduce heat to desired temperature for cooking, and place food on cooking grate as desired. Close lid to retain more smoke. Hardwood varieties that work particularly well with grilled foods include Alder, Apple, Cherry, Hickory, Mesquite, and Pecan.



Skewers

Metal skewers should be flat, with long handles. Round skewers allow food to roll when turned, so it may not cook as evenly. Use metal skewers when cooking meat kabobs. Wooden skewers should be soaked in water for an hour before use, and are best used for quick cooking foods such as vegetables and fruits.



Utensils

Use tongs or a spatula to handle the food instead of a fork, and don't turn the food too often. Piercing the food with a fork will release juices that you want in the meat, and may cause flare-ups.

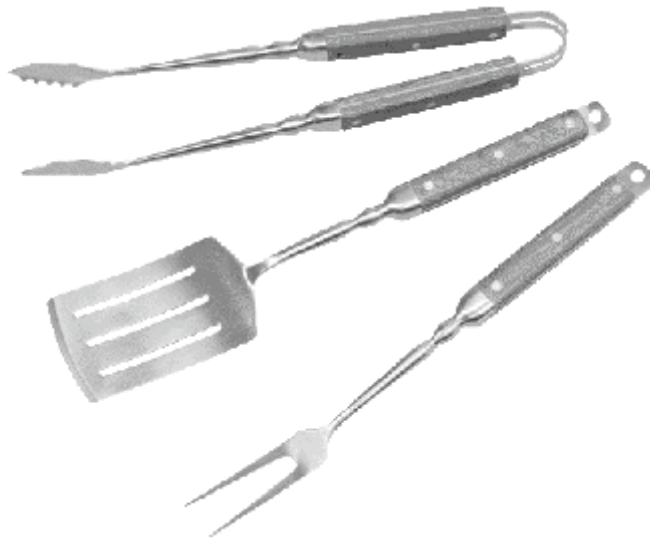

GRILLING GUIDE – Cleaning Your Grill

Why Clean?

We've all heard the saying 'An ounce of prevention is worth a pound of cure'. This is great advice when it comes to keeping your grill clean.

Routine Care

Periodic cleaning of this grill is necessary, as grill fires can occur when grease and food debris collect in the bottom of the grill. After each use, remove any remaining food particles from the cooking grate and inside of the grill using a grill brush. Do this after the grill has cooled down. This grill is not designed to be 'burned off' by closing the lid and turning the burners on High for an extended time. The excessive heat generated can cause leftover grease to catch fire, and can cause permanent damage to your grill.

General Cleaning

Plastic parts: Wash with warm soapy water and wipe dry. Do not use abrasive cleaners, degreasers or a concentrated grill cleaner on plastic parts. Damage to and failure of parts can result.

Porcelain surfaces: Because of glass-like composition, most residue can be wiped away with baking soda/water solution or glass cleaner. Use non-abrasive scouring powder for stubborn stains.

Painted surfaces: Wash with mild detergent or non-abrasive cleaner and warm water. Wipe dry with a soft non-abrasive cloth.

Stainless steel surfaces: Stainless steel can rust under certain conditions. This can be caused by environmental conditions such as chlorine or salt water, or improper cleaning tools such as wire or steel wool. It can also discolor due to heat, chemicals, or grease build-up. To maintain your grill's high quality appearance, wash with mild detergent and warm water, or use a stainless steel grill cleaner. Baked-on grease deposits may require the use of an abrasive plastic cleaning pad. Use only in direction of brushed finish to avoid damage. Do not use abrasive pad on areas with graphics.



Cooking surfaces: Ensure no loose bristles remain on cooking surfaces prior to grilling. It is not recommended to clean cooking surfaces while grill is hot.

Storing Your Grill

- Clean cooking grates.
- Store grill in dry location.
- When LP cylinder is connected to grill, store outdoors in a well ventilated space and out of reach of children.
- Cover grill if stored outdoors. Choose from a variety of grill covers offered by Char-Broil at charbroil.com.
- Store grill indoors ONLY if LP cylinder is turned off, disconnected, and removed from grill. Never store LP cylinder indoors.
- When removing grill from storage, follow the 'Cleaning the Burner Assembly' instructions in the Use and Care section of the Product Guide.

Critters

Spiders like to make their homes in the venturi tubes of grills. These must be inspected and cleaned regularly to ensure there are no blockages. Refer to the Use and Care portion of this Product Guide for complete information.

GEARTRAX™

The Char-Broil® grill is equipped with Gear Trax™, which allow for the easy mounting of our unique line of Gear Trax accessories. Please visit charbroil.com for a complete list of Gear Trax accessories. *Available on most models.

VISIT CHARBROIL.COM FOR ALL YOUR GRILLING NEEDS!