

This Owner's Manual is provided and hosted by [Appliance Factory Parts](#).

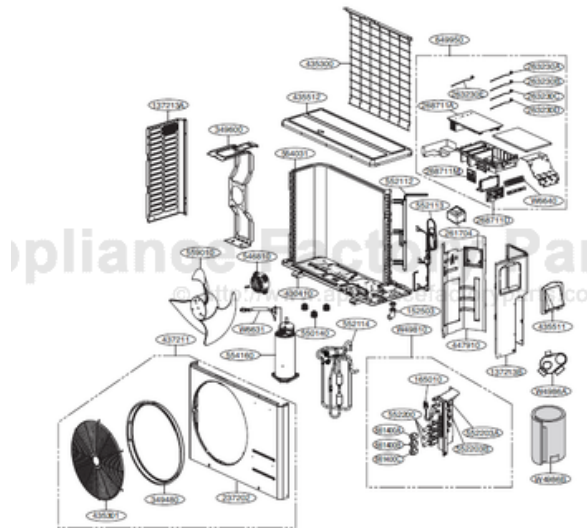

LG LMU24CHV Owner's Manual

[Shop genuine replacement parts for LG LMU24CHV](#)



[Find Your LG Air Conditioner Parts - Select From 2330 Models](#)

----- Manual continues below -----



Internal Use Only

<http://biz.lgservice.com>

Multi Air Conditioner

SVC MANUAL(Exploded View)

MODEL : A3UW24GFA0
[LMU24CHV]

CAUTION

Before Servicing the unit, read the safety precautions in General SVC manual.
Only for authorized service personnel.

1. Specification

Outdoor unit				A3UW24GFA0 [LMU24CHV]
Testing Combination				AMNW09GDBL1 * 2EA + AMNW07GDBL1 * 1EA
Capacity	Cooling	Min.~Rated~Max.	kW	5.86
		Min.~Rated~Max.	Btu/h	20,000
	Heating	Min.~Rated~Max.	kW	7.0
		Min.~Rated~Max.	Btu/h	24,000
Power Input	Cooling	Min.~Rated~Max.	kW	1.48
	Heating	Min.~Rated~Max.	kW	1.8
EER			Btu/Wh	13.5
SEER / HSPF			-	21.7/10.6
Power Supply			V, Ø, Hz	208/230, 1, 60
Running Current	Cooling	Min.~Rated~Max.	A	6.7
	Heating	Min.~Rated~Max.	A	8.1
Starting Current	Cooling	Max.	A	-
	Heating	Max.	A	-
Wiring Connections	Power Supply Cable (included Earth)		No. x mm ² (AWG)	3C x 2.5 (12)
	Power and Communication Cable (included Earth)	Outdoor ~ BD unit	No. x mm ² (AWG)	-
Combination	Sum of Indoor Units Capacity		kBtu/h	33
	Number of Indoor Units		EA	3
	Number of BD Units		EA	-
Casing Color			-	Warm Gray
Dimensions	W x H x D		mm	870 x 655 x 320
	W x H x D		inch	34-1/4 x 25-25/32 x 12-19/32
Net Weight			kg (lbs)	45 (99.2)
Compressor	Type			Twin Rotary
	Model	Model x No.		GKT176MA x 1
	Motor type			BLDC
	Motor Output	W x No.		1,500 (at 60Hz) x 1
Refrigerant	Type			R410A
	Precharged Amount	g (oz)		1,800 (63.5)
	Chargeless-Pipe Length	m (ft)		22.5 (73.8)
	Additional Charging Volume	g/m (oz/ft)		20 (0.22)
	Control			Electronic Expansion Valve
Refrigerant Oil	Type			FVC68D
	Charged volume	cc x No.		670 x 1
Heat Exchanger			(Row x Column x Fins per inch) x No.	(2 x 28 x 14) x 1
Fan	Type			Propeller
	Air Flow Rate	m ³ /min x No.		50 x 1
Fan Motor	Type			BLDC
	Output	W x No.		85.4 x 1
Sound Pressure Level	Cooling	Rated	dB(A)	50
	Heating	Rated	dB(A)	53
Sound Power Level	Cooling	Rated	dB(A)	62
Piping Connections	Liquid	Outer Dia.	mm(inch) x No.	Ø 6.35 (1/4) x 3
	Gas	Outer Dia.	mm(inch) x No.	Ø 9.52 (3/8) x 3
Piping Length	Total Piping	Max.	m (ft)	75(246.0)
	Main Piping	Max.	m (ft)	-
	Total Branch Piping	Max.	m (ft)	-
	Each Branch Piping	Max.	m (ft)	25 (82.0)
Maximum Height Difference	Outdoor Unit ~ Indoor Unit	Max.	m (ft)	15 (49.2)
	Indoor Unit ~ Indoor Unit	Max.	m (ft)	7.5 (24.6)
Operation Range (Outdoor Temperature)	Cooling	Min. ~ Max.	°C DB (°F DB)	-18(-0.4) * ~ 48 (118.4)
	Heating	Min. ~ Max.	°C WB (°F WB)	-20 (-4.0) ~ 18 (64.4)

Note:

- All data are based on the following conditions:
 - Cooling Temperature : Indoor 26.7°C(80°F) DB / 19.4°C(67°F) WB
Outdoor 35°C(95°F) DB / 23.9°C(75°F) WB
 - Heating Temperature : Indoor 21.1°C(70°F) DB / 15.6°C(60°F) WB
Outdoor 8.3°C(47°F) DB / 6.1°C(43°F) WB
 - Piping Length : Interconnected Pipe Length = 7.5m
 - Difference Limit of Elevation (Outdoor ~ Indoor Unit) is Zero.

- Wiring cable size must comply with the applicable local and national code.
- Due to our policy of innovation some specifications may be changed without notification.
- Sound Level Values are measured at Anechoic chamber. Therefore, these values can be increased(maximum 3dB(A)) owing to ambient conditions during operation.

*: This temperature(-20 ~ -10°C) can be operated only when Low Ambient Kit is installed.

2. List of Functions & Accessory

2.1 List of Functions

Function		A3UW24GFA0 [LMU24CHV]
Reliability	Defrost / Deicing	O
	Phase Protection	X
	Restart Delay(3-minutes)	O
	Self Diagnosis	O
	Soft Start	O
	Test Function	X
Convenience	Wiring Error Check	O
	Night Quiet Mode	O
	Mode Lock	O
	Peak Control	O
	Forced Operation	O
CAC Network Function	Central Control(LGAP)	O
	PDI(Power Distribution Indicator)	O
	PI485	O

Note :

O : Applied, x : Not applied

* Option : Model name & price are different according to options, and assembled in factory with main unit.

Accessory model name : Installed at field, ordered and purchased separately by the corresponding model name, supplied with separate package.

2.2 List of Accessory

Device		A3UW24GFA0 [LMU24CHV]
Central Controller	Simple Controller	X
	Function controller	X
	Function Scheduler	X
	AC Ez	PQCSZ250S0
	AC Smart II	PQCSW320A1E
	Option Kit (SD card type)	PQCSE341A0 / PQCSE342A0
	ACP(Advanced Control Platform)	PQCPA11A0E / PQCPB11A0E
	AC Manager	X
	PI485	PMNFP14A0 / PMNFP14A1
	DO(Digital Output) Kit	PQNFP00T0
BNU (Building Network Unit)	LONWORKS Gateway	PQNFB16A1
	BACnet Gateway	PQNFB17B0
Installation	Y branch X X	X
	Header branch	X
	Air Guide	X
ODU Dry Contact		X
Low Ambient Kit		O (Logical operation)

3. Piping Diagrams

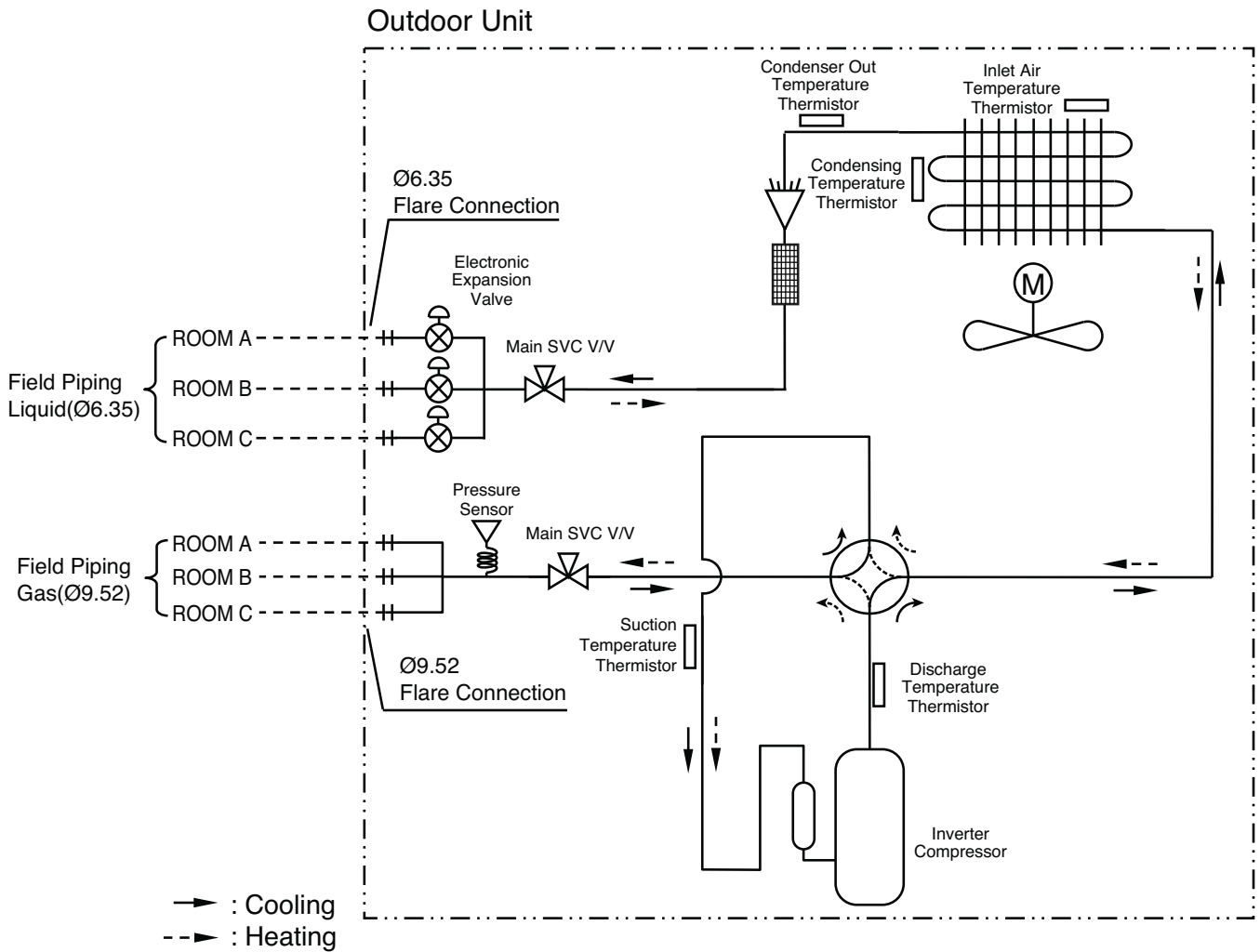

4. Wiring Diagrams

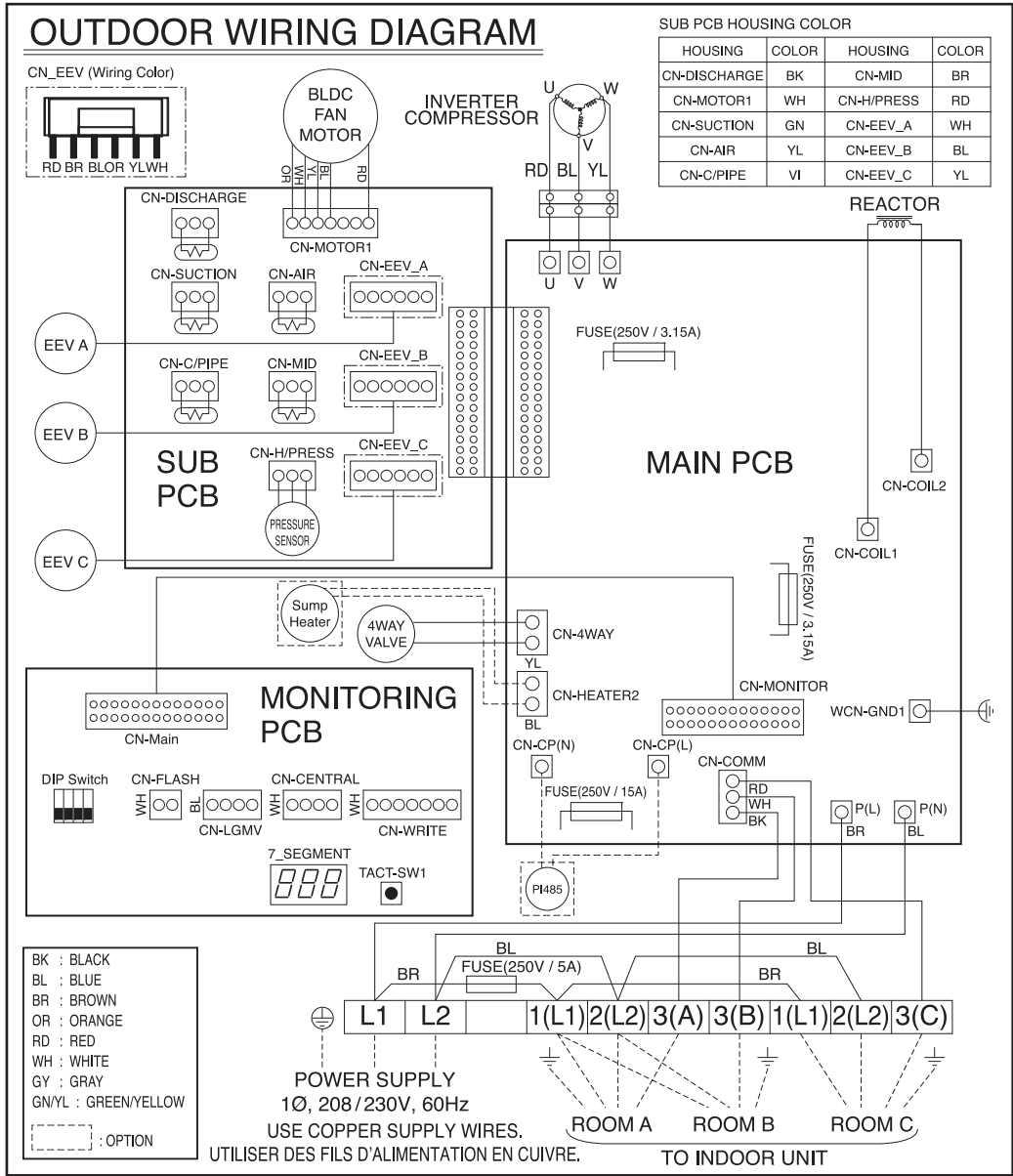

5. Exploded View

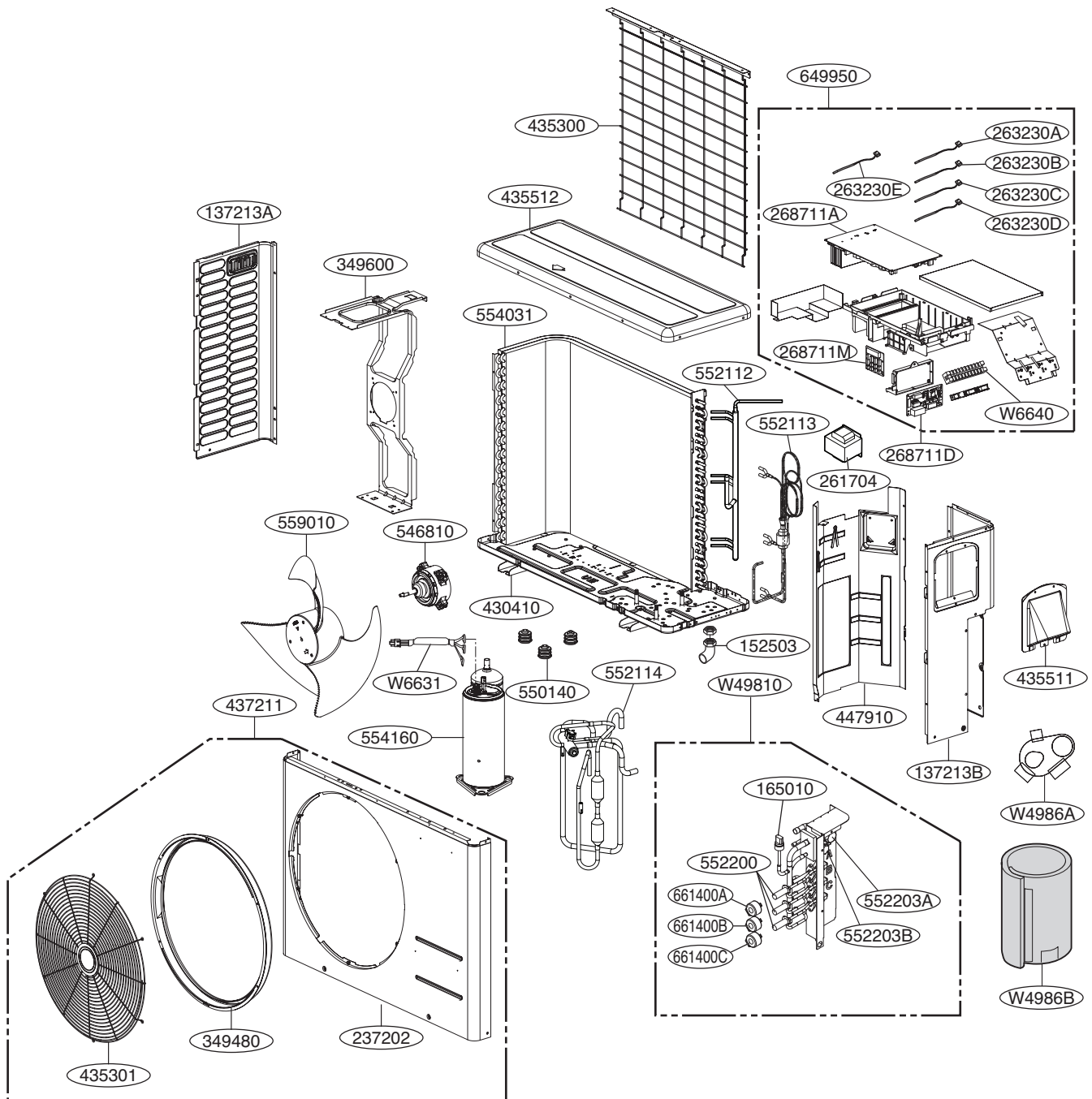

Location No.	Description	Sensor Information	Housing Color
263230A	Thermisther1(CN-DISCHARGE)	Discharge Pipe	Black
263230B	Thermisther2(CN-SUCTION)	Suction Pipe	Green
263230C	Thermisther3(CN-C/PIPE)	Cond Out Pipe	Violet
263230D	Thermisther4(CN-MID)	Cond Middle Pipe	Brown
263230E	Thermisther5CN-Air)	Air	Yellow
165010	CN-H/PRESS	Pressure sensor	Red



P/NO : MFL68280002

January, 2014