

This Owner's Manual is provided and hosted by [Appliance Factory Parts](#).

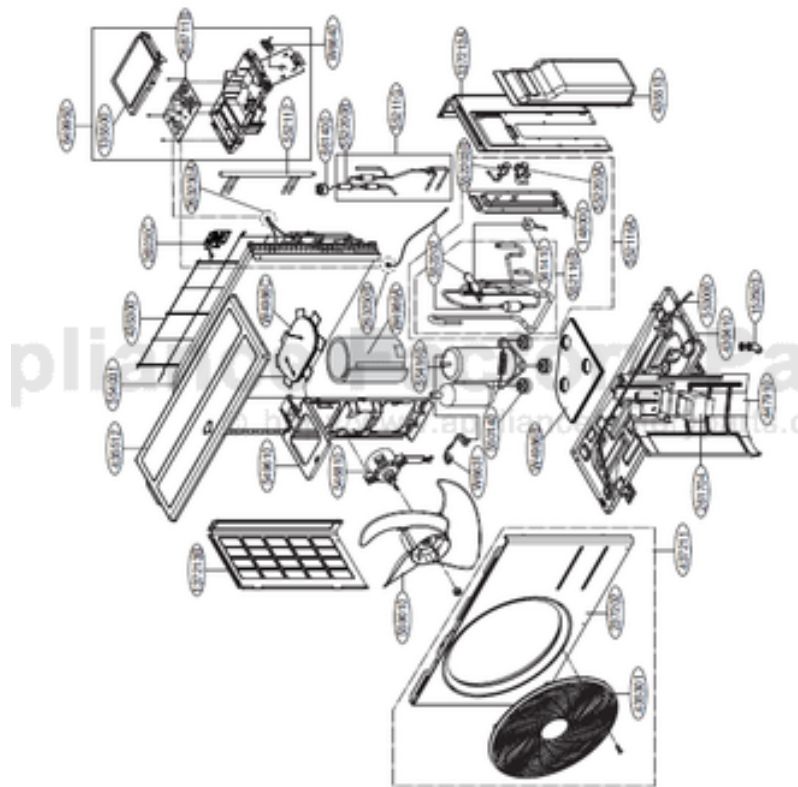

LG AS-W093B1B8 Owner's Manual

[Shop genuine replacement parts for LG AS-W093B1B8](#)



[Find Your LG Air Conditioner Parts - Select From 2330 Models](#)

----- Manual continues below -----



Internal Use Only

<http://biz.lgservice.com>

Room Air Conditioner

SVC MANUAL(Exploded View)

**MODEL : AS-W093B1B8(LSN091HSV3 / LSU091HSV3)
AS-W123B1B8(LSN121HSV3 / LSU121HSV3)**

CAUTION

Before Servicing the unit, read the safety precautions in General SVC manual.
Only for authorized service personnel.

Product Specifications

Models		Unit	AS-W093B1B8	AS-W123B1B8	
Cooling Capacity		kW	0.89~2.64~3.70	0.89~3.28~4.30	
		Btu/h.	3,070~9,000~12,620	3,070~11,200~14,660	
Heating Capacity		kW	0.89~3.17~5.00	0.89~3.90~6.00	
		Btu/h.	3,070~10,800~17,060	3,070~13,300~20,470	
Power Input	Cooling/Heating	W	677/700	896/1000	
Running Current	Cooling/Heating	A	3.0/3.7	4.2/4.9	
Starting Current	Cooling/Heating	A	3.0/3.7	4.2/4.9	
EER		W/W	3.9	3.66	
		Btu/h.W	13.3	12.5	
SEER		-	21.5	21.5	
HSPF		-	11	11	
Power Supply		Ø / V / Hz	1/208-230/60	1/208-230/60	
Power Factor		%	93	97.1	
Air Flow Rate	Indoor,Max	m³/min(CFM)	11(388)	12(423)	
	Outdoor,Max	m³/min(CFM)	33(1,165)	33(1,165)	
Moisture Removal		l/h.	1.1(2.6)	1.3(3.0)	
Sound Level	Indoor,H/M/L/Sleep	dB(A)±3	38 / 33 / 24 / 19	39 / 33 / 24 / 19	
	Outdoor,Max	dB(A)±3	45	45	
Refrigerant & Charge (at 7.5 m)		g(oz)	R410A, 1,000(35.3)	R410A, 1,000(40.6)	
Additional Refrigerant charge		g/m(oz/ft)	20(0.22)	20(0.22)	
Compressor	Type		Single Rotary	Single Rotary	
	Model		GA102MFB	GA102MFB	
	Motor Type		Brushless DC Motor	Brushless DC Motor	
	Oil Type		FVC68D	FVC68D	
	Oil Charge	cc	310	310	
	O.L.P. name		-	-	
Fan(Indoor)	Type		Cross Flow Fan	Cross Flow Fan	
	Motor Output	W	20	20	
Fan(Outdoor)	Type		Propeller, Fan	Propeller, Fan	
	Motor Type		BLDC	BLDC	
	Motor Output	W	43	43	
Circuit Breaker*		A	15	15	
Power Supply Cable		No.*mm²	3*1.0	3*1.0	
Power and Transmission Cable No.*mm2		No.*mm²	4*1.0 (Including Earth)	4*1.0 (Including Earth)	
Piping Connections	Liquid Side	mm(in)	6.35(1/4)	6.35(1/4)	
	Gas Side	mm(in)	9.52(3/8)	9.52(3/8)	
Drain Hose(O.D / I.D.)		mm(in)	21.5 / 16.0(0.85 / 0.63)	21.5 / 16.0(0.85 / 0.63)	
Dimensions	Indoor (W*H*D)	mm	885*285*210	885*285*210	
		inch	35.2*11.2*8.26	35.2*11.2*8.16	
	Outdoor (W*H*D)	mm	770*545*288	770*545*288	
		inch	30.3*21.3*11.3	30.3*21.3*11.3	
Net Weight	Indoor	kg(lbs)	10.2(22.5)	10.2(22.5)	
	Outdoor	kg(lbs)	34(78)	34(78)	
Gross Weight	Indoor	kg(lbs)	12.4(27.3)	12.4(27.3)	
	Outdoor	kg(lbs)	35.8(78.9)	35.8(78.9)	
Operation Range	Cooling(Outdoor)	°C(°F)	-18~-48(-0.4~-118.4)	-18~-48(-0.4~-118.4)	
	Heating(Outdoor)	°C(°F)	-20 ~ 24 (-4 ~ 75.2)	-20 ~ 24 (-4 ~ 75.2)	
Piping Length (Min/Max)		m(ft)	2(6.6) / 20(65.6)	2(6.6) / 20(65.6)	
Chargeless		m(ft)	12.5(41.0)	12.5(41.0)	
Max. Elevation Difference		m(ft)	10(32.8)	10(32.8)	
Tool Code(Chassis)	Indoor + Outdoor		SB + UL2	SB + UL2	
Functions	Temperature Control		Thermistor	Thermistor	
	Allergy free filter		-	-	
	Plasma Filter + 2 NPI		-	-	
	Prefilter(washable/anti-fungus)		O	O	
	3M Micro Protection Filter		O	O	
	Auto Clean		O	O	
	CHAOS Wind(Auto Wind)		O	O	
	Steps, Fan/Cool/Heat		5/6/5	5/6/5	
	Airflow Direction Control(up& Down)		Auto	Auto	
	Airflow Direction Control(left & right)		Auto	Auto	
	Remote Controller Type		Better	Better	
	Setting Temperature Range	Cooling		18°C ~ 30°C	18°C ~ 30°C
		Heating		16°C ~ 30°C	16°C ~ 30°C
	Auto Operation (Micom Control)		-	-	
	Auto Changeover (Micom Control)		O	O	
	Self Diagnosis		O	O	
	Timer		24h, On/Off	24h, On/Off	
	Sleep Operation		O	O	
	Soft Dry Operation		O	O	
	Restart Delay(minute)		3	3	
	Deice Control(Defrost)		O	O	
	Hot Start		O	O	
	Jet Cool		O	O	
	Low Ambient Operation		O	O	
	Special Function			Water Level Sensor, Cooling Only Switch, Wind Baffle Kit, WLAN	

Note:

O : Applied, - : No relation

* For circuit breaker rating, please conform to local standards wherever necessary.

* If you use WLAN, WLAN module must be purchased separately.

* Some of functions are slightly different depending upon models.

* The specification may be subject to change without notice for purpose of improvement.

2. Piping Diagrams

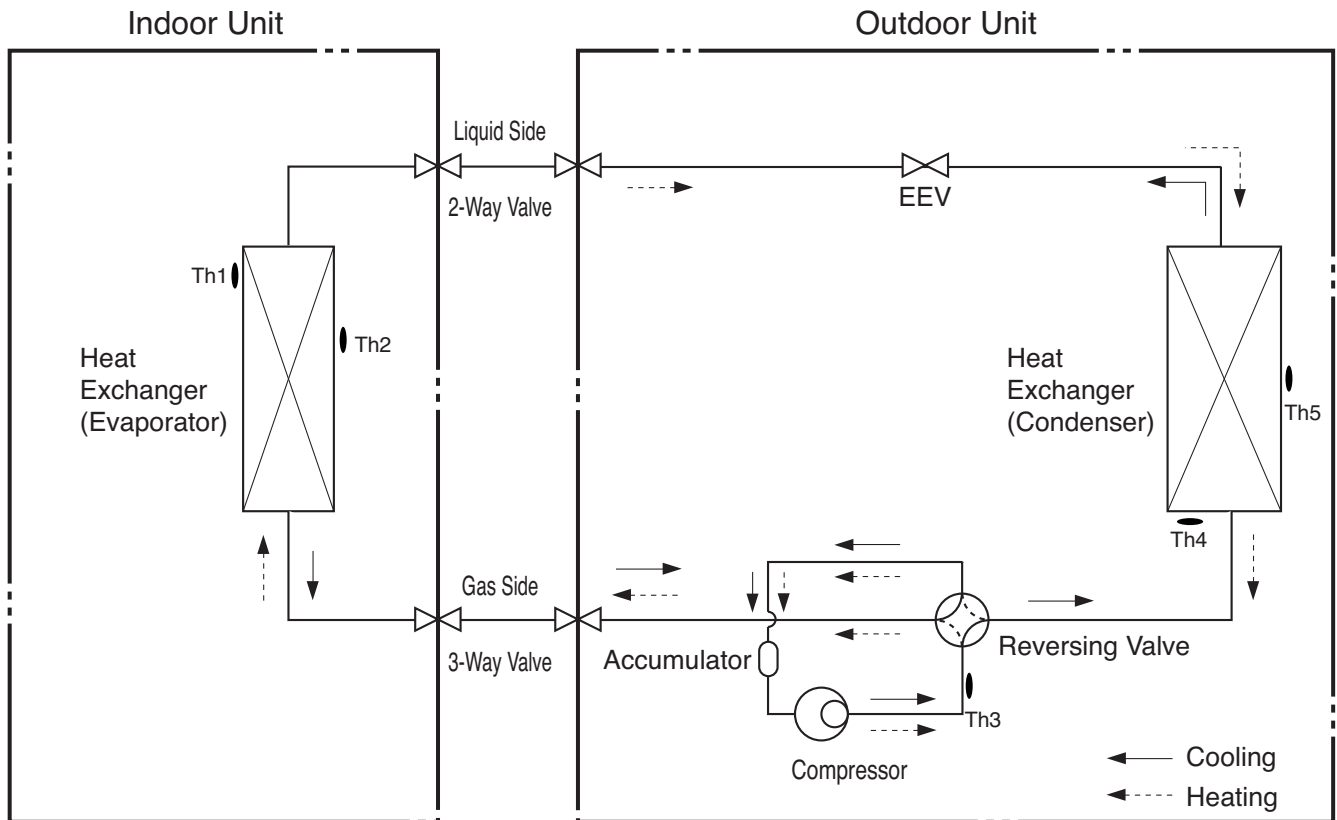

LOC.	Description	PCB Connector
Th1	Thermistor for suction air temperature	CN-TH1(Indoor)
Th2	Thermistor for evaporator middle temperature	CN-TH3(Indoor)
Th3	Thermistor for discharge pipe temperature	CN-TH2(OUTDOOR)
Th4	Thermistor for condensing temperature	CN-TH1(OUTDOOR)
Th5	Thermistor for outdoor air temperature	CN-TH1(OUTDOOR)

※ EEV : Electronic Expansion Valve

3. Wiring Diagrams

Indoor Unit

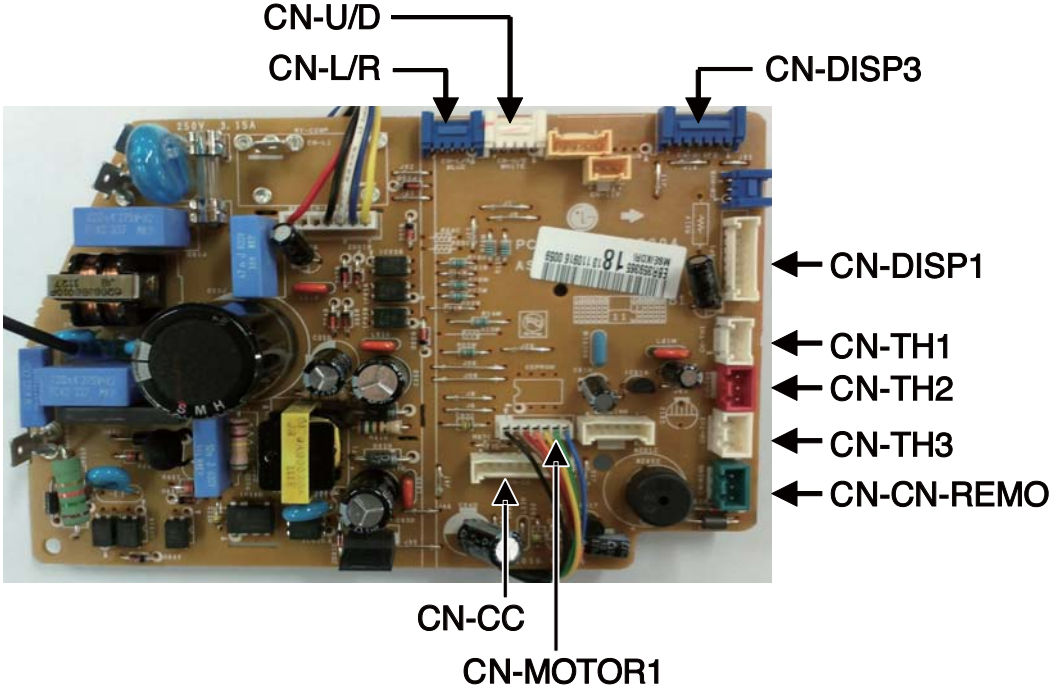
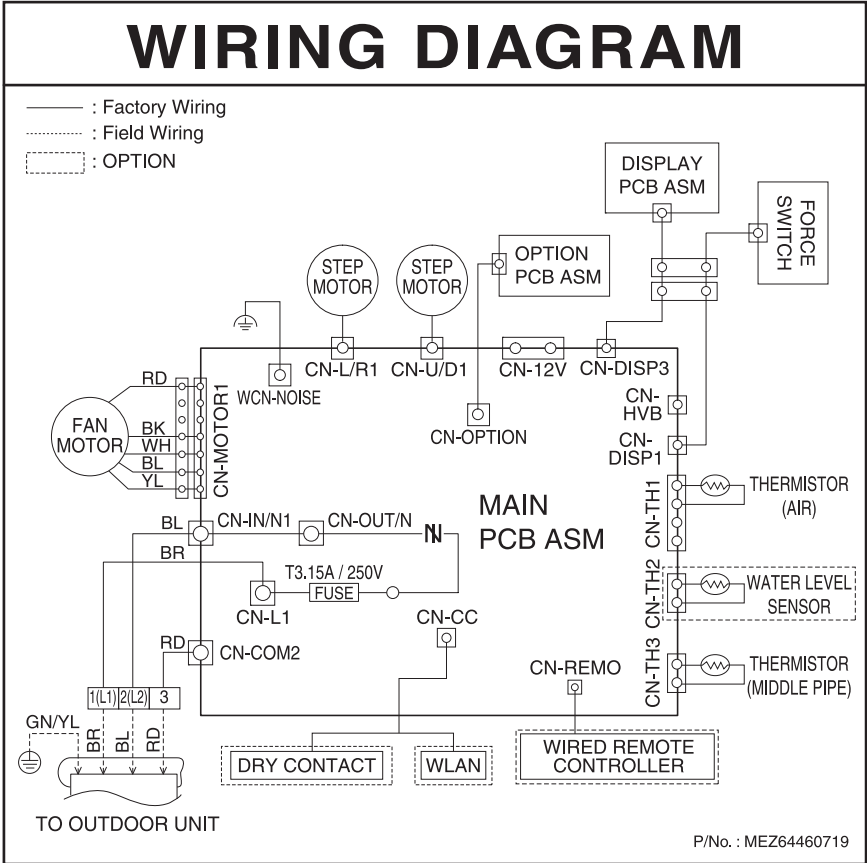

Outdoor Unit

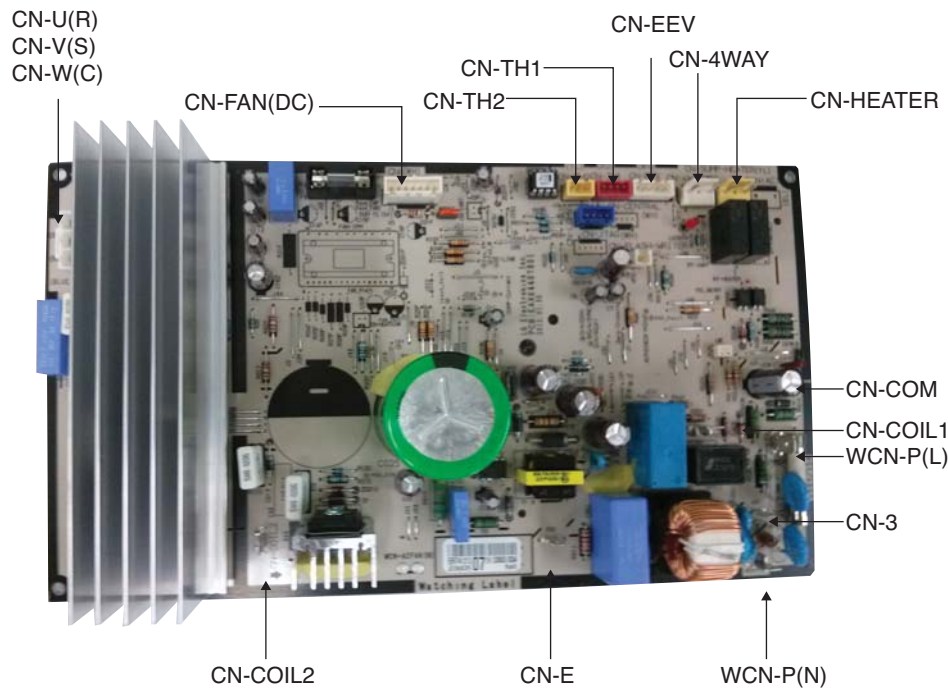
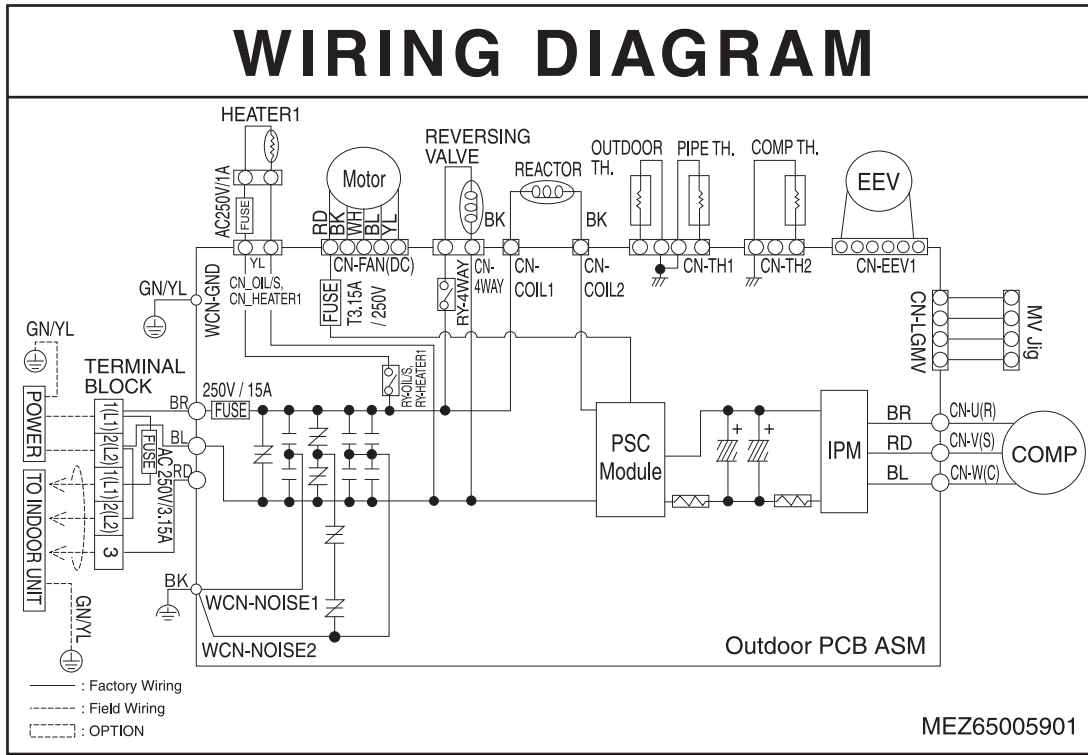

Exploded View

Indoor Unit

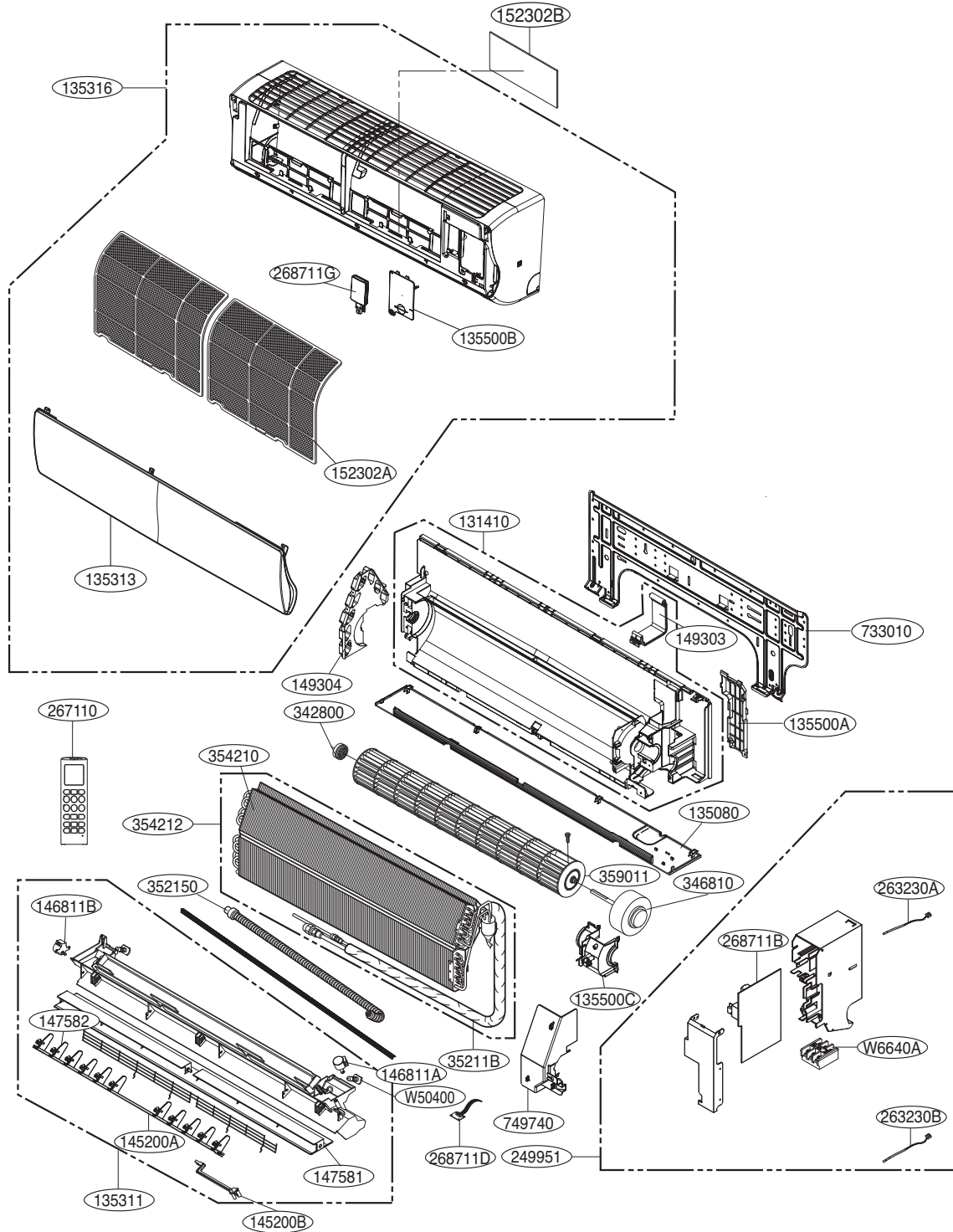

LOC.	Description
263230B	Thermistor for suction air temperature
263230A	Thermistor for evaporator middle temperature

Outdoor Unit

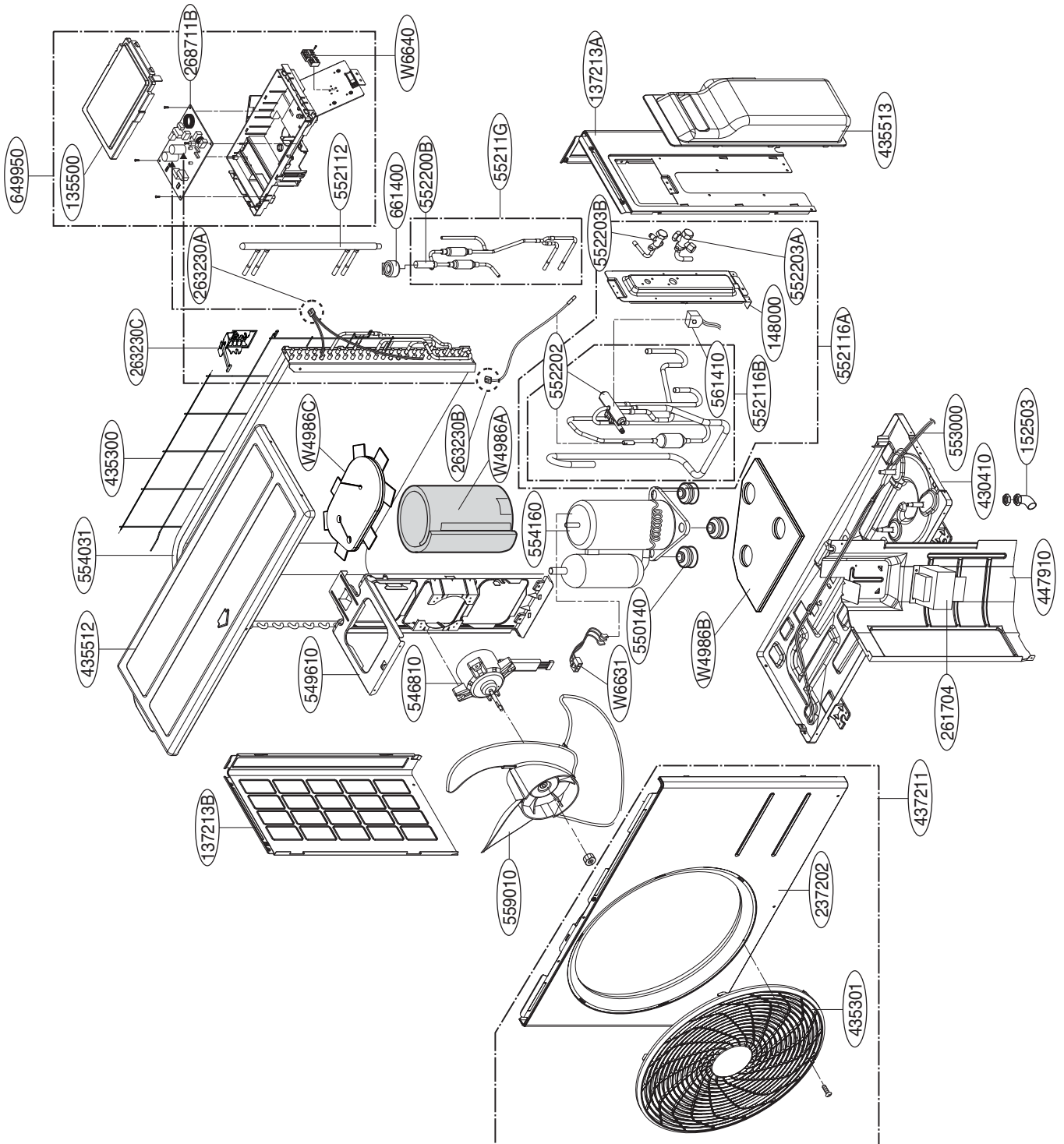

LOC.	Description
263230A	Thermistor for suction air temperature
	Thermistor for condenser inlet temperature
263230B	Thermistor for condenser outlet temperature



US	1. Please call the installing contractor of your product, as warranty service will be provided by them. 2. If you have service issues that have not been addressed by the contractor, please call 1-888-865-3026.
CANADA	Service call Number # : (888) LG Canada, (888) 542-2623

P/NO : MFL67501906

July, 2013