

This Owner's Manual is provided and hosted by [Appliance Factory Parts](http://Appliance Factory Parts).

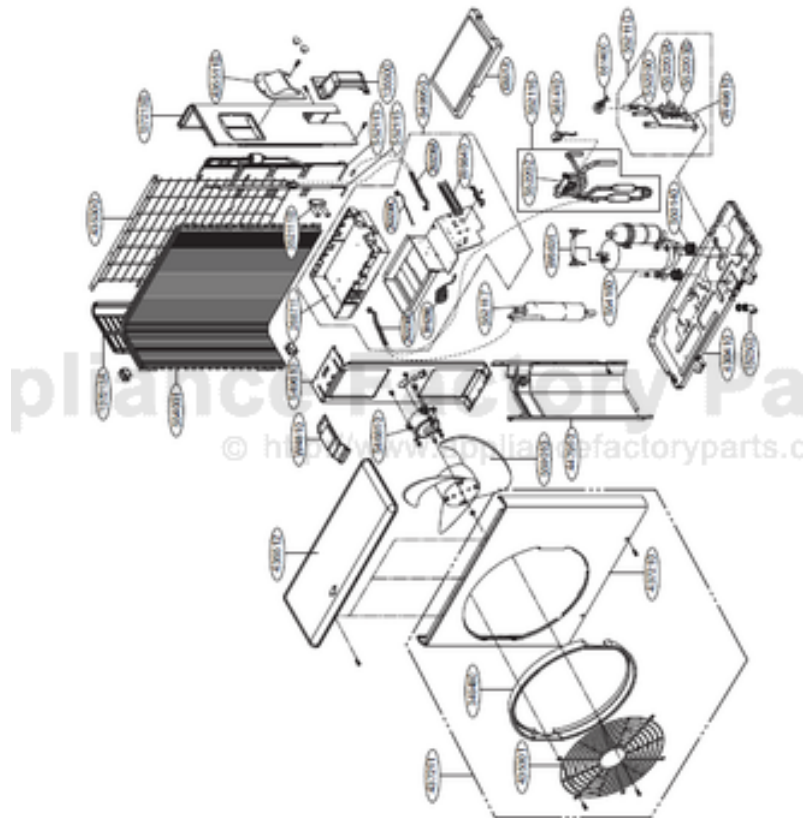

# LG AS-W363DGY9 Owner's Manual

[Shop genuine replacement parts for LG AS-W363DGY9](#)



[Find Your LG Air Conditioner Parts - Select From 2330 Models](#)

----- Manual continues below -----



Internal Use Only

<http://biz.lgservice.com>

# Room Air Conditioner

## SVC MANUAL(Exploded View)

**MODEL : AS-W243DGY9(LSN240HSV2/LSU240HSV2)  
AS-W303DGY9(LSN307HV2/LSU307HV2)  
AS-W363DGY9(LSN360HV2/LSU360HV2)**

### **CAUTION**

Before Servicing the unit, read the safety precautions in General SVC manual.  
Only for authorized service personnel.

# 1. Product Specifications

Sales Model		LSN240HSV2/LSU240HSV2	LSN307HV2/LSU307HV2	LSN360HV2/LSU360HV2	
Models		AS-W243DGY9	AS-W303DGY9	AS-W363DGY9	
Cooling Capacity	Unit	kW	0.90~6.45~8.8	0.90~9.67~9.96	
		Btu/h	3,070/22,000/30,030	3,070/30,000/34,000	
Heating Capacity	Unit	kW	0.90~8.09~11.40	0.90~9.38~11.40	
		Btu/h	3,070/27,600/38,900	3,070/32,000/38,900	
Power Input	Cooling/Heating	W	1,780/2,380	3,000/3,100	
Running Current	Cooling/Heating	A	7.9 / 10.7	13.4/13.9	
Starting Current	Cooling/Heating	A	7.9 / 10.7	13.4/13.9	
EER/COP	Unit	W/W	5.4 / 4.3	3.2 / 3.3	
		Btu/h.W	12.4 / 11.6	10 / 10.3	
SEER			18.9	18	
HSPF			10.2	9.5	
Power Supply		Ø/V/Hz	1/208~230/60	1/208~230/60	
Power Factor		%	98.2	97.3	
Air Flow Rate	Indoor,Max	m³/min(CFM)	25(883)	25(883)	
	Outdoor,Max	m³/min(CFM)	60(2,119)	60(2,119)	
Moisture Removal		l/h	4.8	4.8	
Sound Level	Indoor, H/M/L	dB(A)+3	47/43/39	49/44/39	
	Outdoor,Max	dB(A)+3	55	55	
Refrigerant & Charge (at 7.5 m)		g(oz)	R410A, 2,000(70.5)	R410A, 2,000(70.5)	
Additional Refrigerant charge		g(m/oz/ft)	35(0.38)	35(0.38)	
Compressor	Type		Twin Rotary	Twin Rotary	
	Model		GJT240DAA	GJT240DAA	
	Motor Type		Brushless DC Motor	Brushless DC Motor	
	Oil Type		PVE(FVD68C)	PVE(FVD68C)	
	Oil Charge	cc	900	900	
	O.L.P name		-	-	
Fan(Indoor)	Type		Cross Flow Fan	Cross Flow Fan	
	Motor Output	W	76.1	76.1	
Fan(Outdoor)	Type		Propeller, Fan	Propeller, Fan	
	Motor Type		BLDC	BLDC	
	Motor Output	W	124	124	
Circuit Breaker*		A	30	30	
Power Supply Cable		No.*mm²	3*2.5	3*2.5	
Power and Transmission Cable No.*mm2		No.*mm²	4*1.0(Including Earth)	4*1.0(Including Earth)	
Piping Connections	Liquid Side	mm(in)	9.52(3/8)	9.52(3/8)	
	Cas Side	mm(in)	15.88(5/8)	15.88(5/8)	
Drain Hose(O.D / I.D)		mm(in)	21.5 / 16.0(0.85/ 0.63)	21.5 / 16.0(0.85/ 0.63)	
Dimensions	Indoor(W*H*D)	mm	1209*346*205	1209*346*205	
		inch	47.6*13.6*8.1	47.6*13.6*8.1	
	Outdoor(W*H*D)	mm	870*800*320	870*800*320	
		inch	34.3*31.8*12.6	34.3*31.8*12.6	
Net Weight	Indoor	kg(lbs)	15.3(33.7)	15.3(33.7)	
	Outdoor	kg(lbs)	63.4(139.8)	63.4(139.8)	
Gross Weight	Indoor	kg(lbs)	19.5(43.0)	19.5(43.0)	
	Outdoor	kg(lbs)	68.7(151.5)	68.7(151.5)	
Operation Range	Cooling(Outdoor)	°C(°F)	-10(-18)~43(14(0)~109.4)	-10(-18)~43(14(0)~109.4)	
	Heating(Outdoor)	°C(°F)	-10~24(14.0~75.2)	-10~24(14.0~75.2)	
Piping Length (Min/Max)		m(ft)	- / 30(98.4)	- / 30(98.4)	
Chargeless		m(ft)	-	-	
Max. Elevation Difference		m(ft)	15(49.2)	15(49.2)	
Tool Code(Chassis)	Indoor + Outdoor		SD + UE1+	SD + UE1+	
Functions	Temperature Control		O	O	
	Allergy free filter		-	-	
	Plasma Filter		O	O	
	Prefilter(washable/anti-fungus)		O	O	
	Auto Clean		O	O	
	CHAOS Wind(Auto Wind)		O	O	
	Steps, Fan/Cool/Heat		3/4/3	3/4/3	
	Airflow Direction Control(up & down)		Auto	Auto	
	Airflow Direction Control(left & right)		Auto	Auto	
	Remote Controller Type		Wireless LCD	Wireless LCD	
	Setting Temperature	Cooling		18°C ~ 30°C	18°C ~ 30°C
		Heating		16°C ~ 30°C	16°C ~ 30°C
	Auto Operation(Micom Control)		-	-	
	Auto Changeover(Micom Control)		O	O	
	Self Diagnosis		O	O	
	Timer		24h, On/Off	24h, On/Off	
	Sleep Operation		O	O	
	Soft Dry Operation		O	O	
	Restart Delay(minute)		3	3	
	Deice Control(Deforst)		O	O	
	Hot Start		O	O	
	Jet Cool/Heat		O	O	
	Low Ambient Operation		O	O	
	Special Function		-	-	

**Note :**

O : Applied, - : No relation

\* For circuit rating, please confirm to local standards wherever necessary

\* With wind baffle accessory installed. With put wind baffle installed, the minimum temperature will below 14°F D.B.

\* Some of functions are slightly different depending upon models

\* The specification may be subject to change without notice for purpose of improvement

## 2. Piping Diagrams

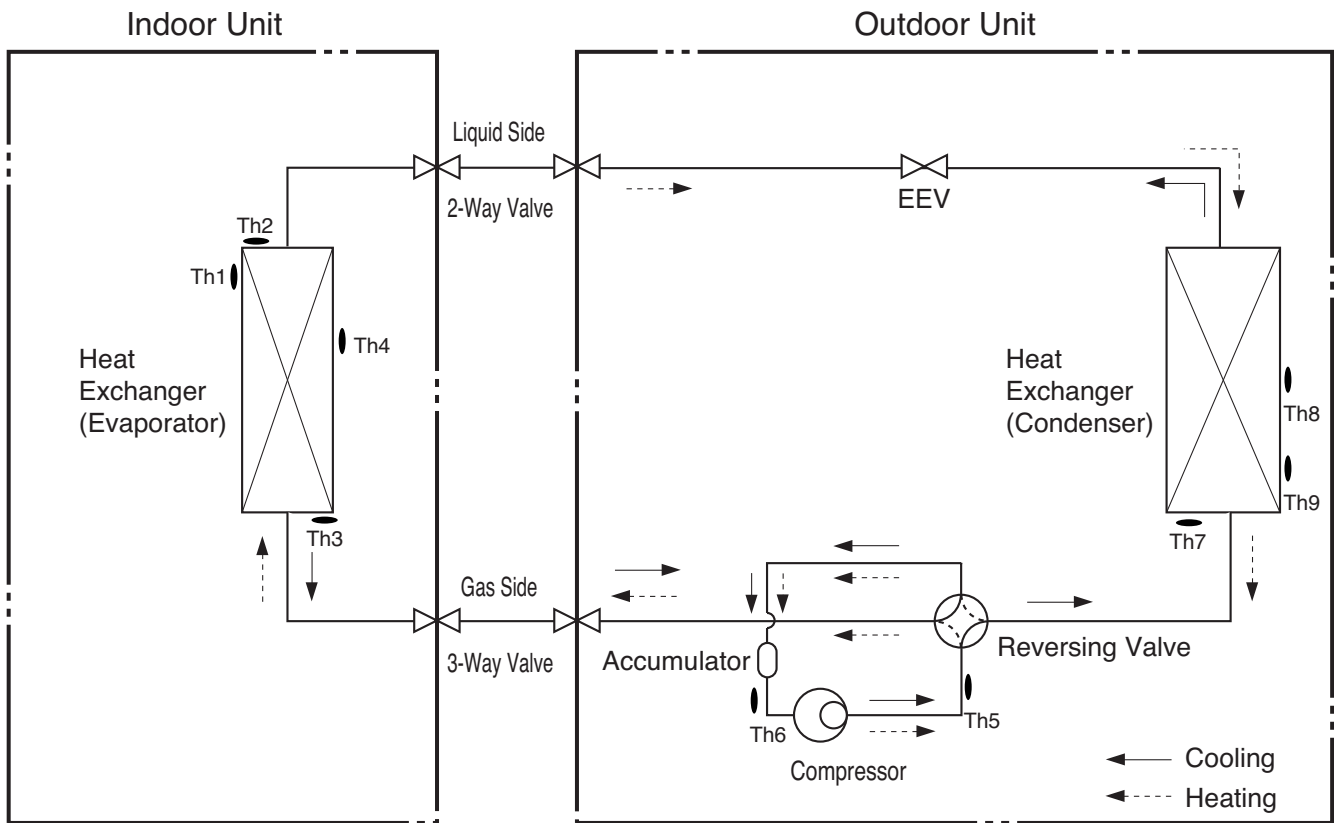

LOC.	Description	PCB Connector
Th1	Thermistor for suction air temperature	CN-TH1(Indoor)
Th2	Thermistor for evaporator inlet temperature	
Th3	Thermistor for evaporator outlet temperature	CN-TH2(Indoor)
Th4	Thermistor for evaporator middle temperature	CN-TH3(Indoor)
Th5	Thermistor for discharge pipe temperature	CN-TH3(OUTDOOR)
Th6	Thermistor for suction pipe temperature	
Th7	Thermistor for condensing temperature	CN-TH2(OUTDOOR)
Th8	Thermistor for outdoor air temperature	
Th9	Thermistor for condensing middle temperature	CN-TH4(OUTDOOR)

※ EEV : Electronic Expansion Valve

### 3. Wiring Diagrams

#### Indoor Unit

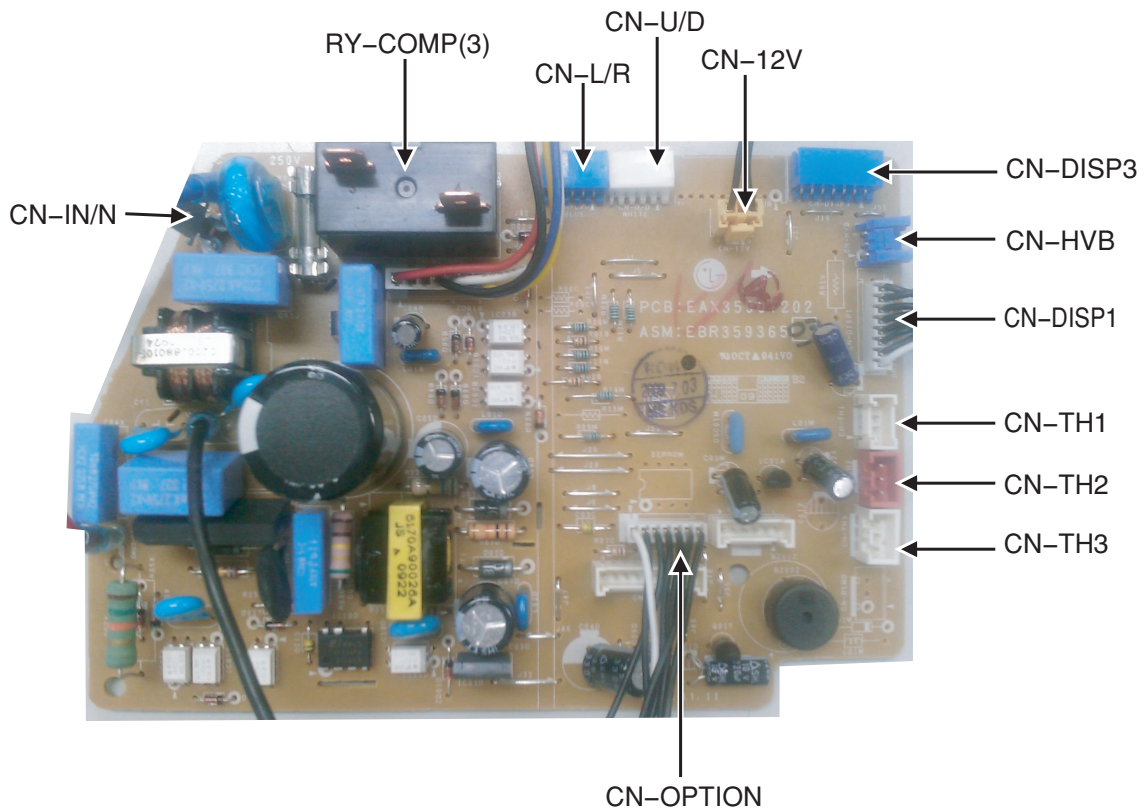
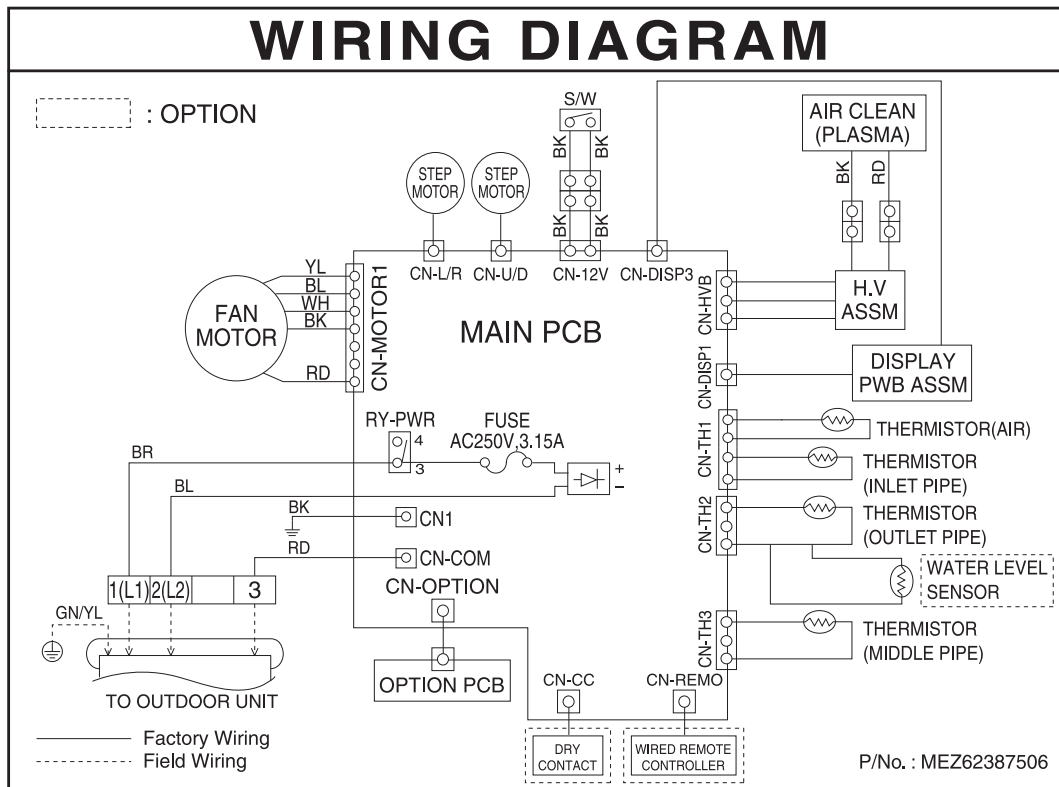

# Outdoor Unit

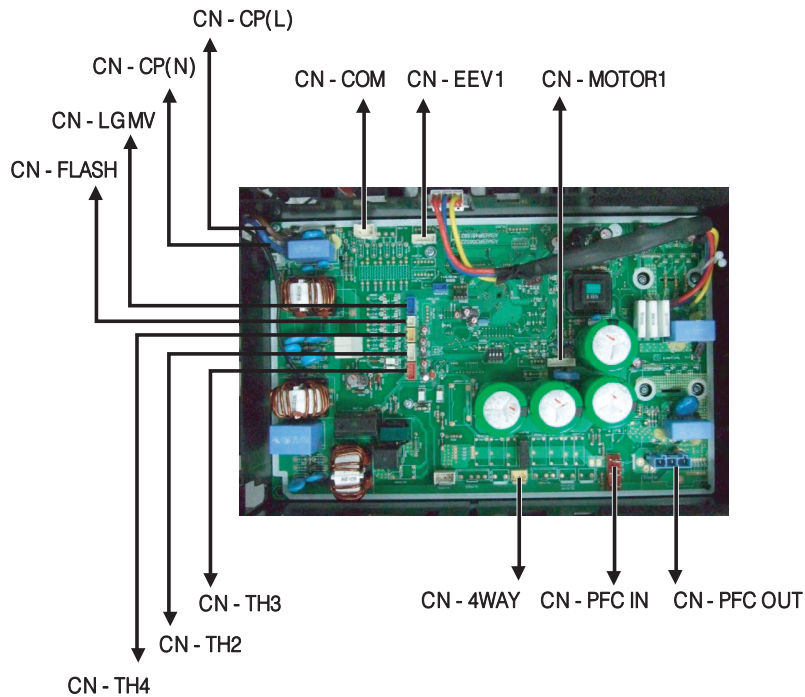
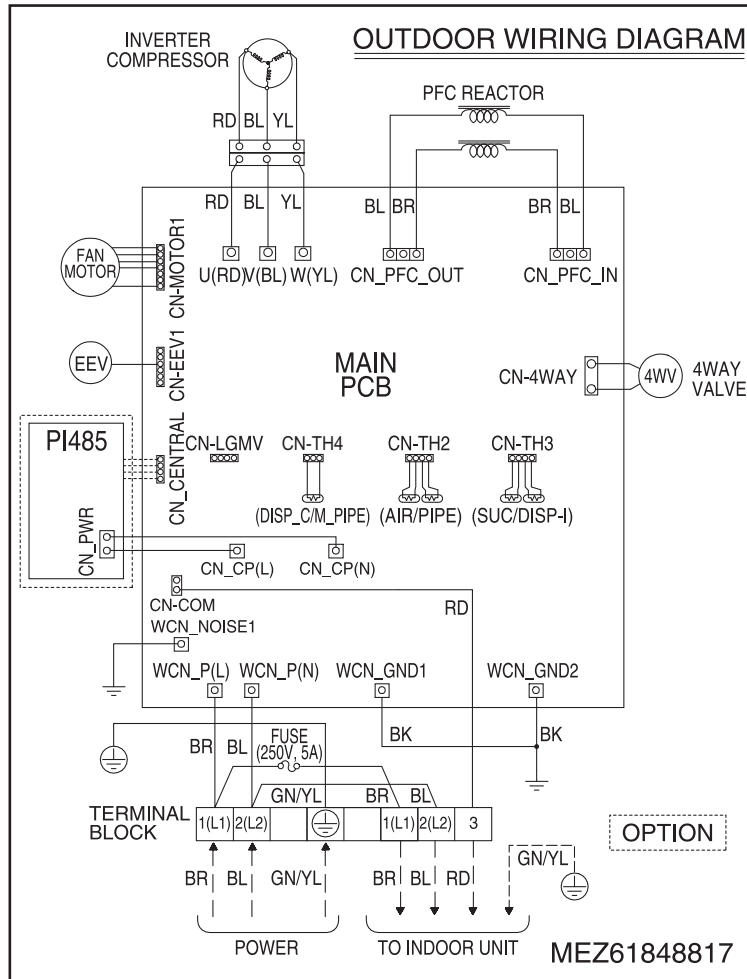

# Exploded View

## Indoor Unit

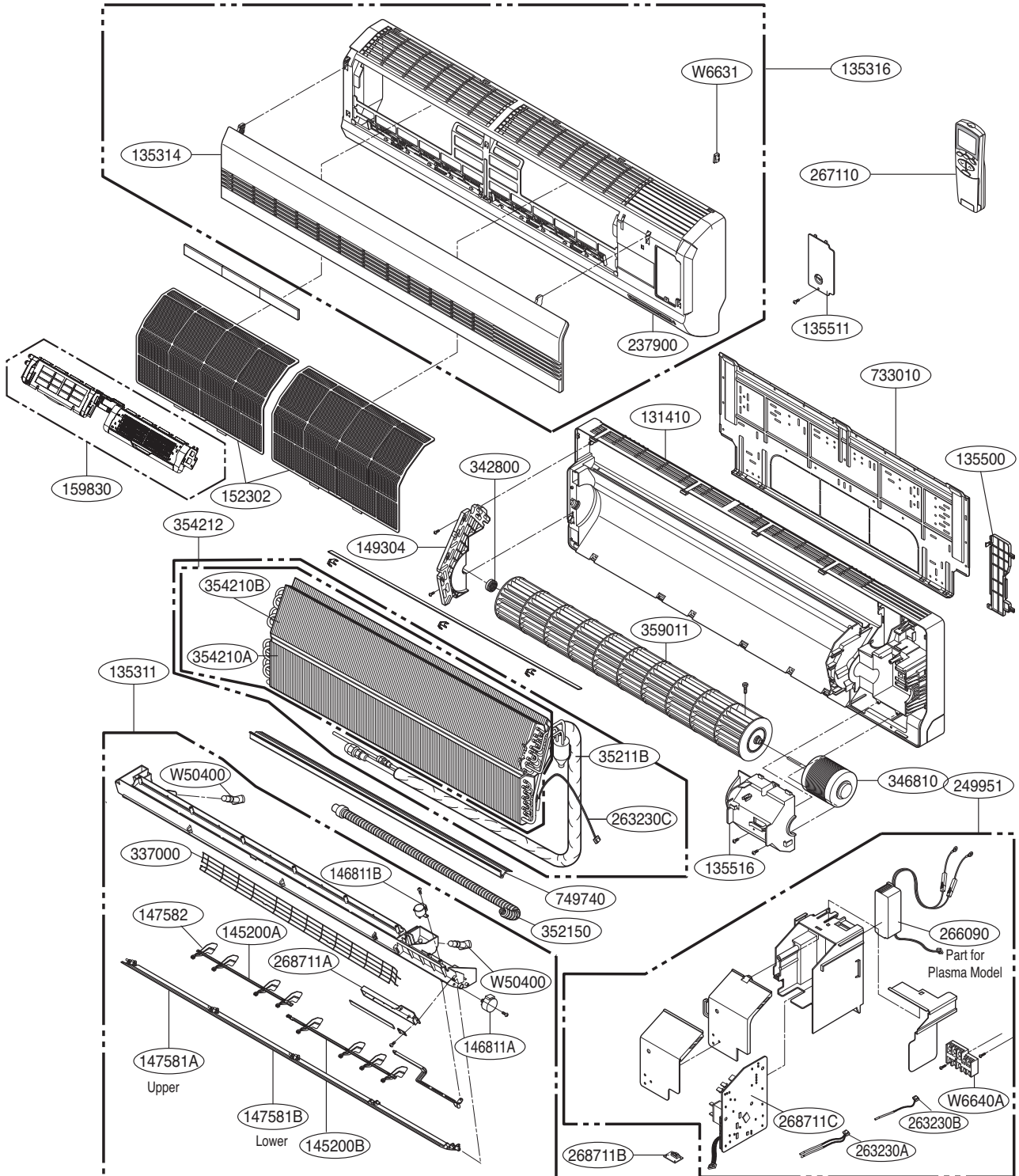

Location No	Description	Connector
263230A	Thermistor for indoor air temperature	TH1
	Thermistor for evaporator inlet temperature	
263230B	Thermistor for evaporator outlet temperature	TH2
263230C	Thermistor for evaporator middle temperature	TH3

# Outdoor Unit

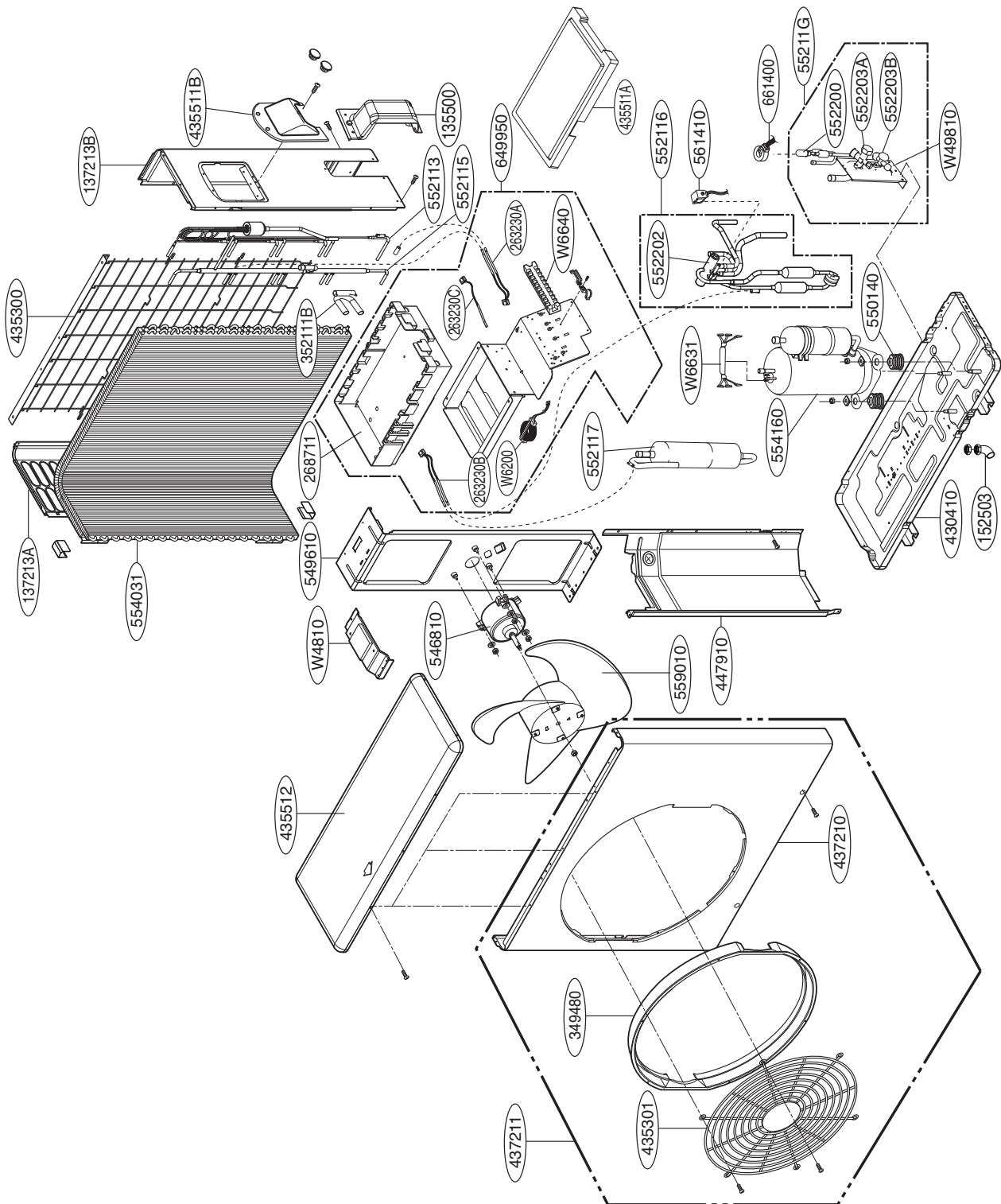

Location No	Description	Connector
263230A	Thermistor for condensing temperature	TH2
	Thermistor for outdoor air temperature	
263230B	Thermistor for discharge pipe temperature	TH3
	Thermistor for suction pipe temperature	
263230C	Thermistor for condensing middle temperature	TH4



US	1. Please call the installing contractor of your product, as warranty service will be provided by them. 2. If you have service issues that have not been addressed by the contractor, please call 1-888-865-3026.
CANADA	Service call Number # : (888) LG Canada, (888) 542-2623

P/NO : MFL67525501

November, 2013