

This Owner's Manual is provided and hosted by [Appliance Factory Parts](#).



LG AMNW12GTRA0 Owner's Manual

[Shop genuine replacement parts for LG
AMNW12GTRA0](#)



[Find Your LG Air Conditioner Parts - Select From 2330 Models](#)

----- Manual continues below -----



Internal Use Only

<http://biz.lgservice.com>

Multi Air Conditioner

SVC MANUAL(Exploded View)

**MODEL : AMNW07GTRA0(LMCN077HV)
AMNW09GTRA0(LMCN097HV)
AMNW12GTRA0(LMCN125HV)
AMNW18GTQA0(LMCN185HV)**

CAUTION

Before Servicing the unit, read the safety precautions in General SVC manual.
Only for authorized service personnel.

1. Specification

Indoor unit type			Ceiling Cassette - 4way	
Model			AMNW07GTRA0[LMCN077HV]	AMNW09GTRA0[LMCN097HV]
Decoration Panel Name			PT-UQC	PT-UQC
Power Supply		V, Ø, Hz	208/230, 1, 60	208/230, 1, 60
Capacity(*)		Btu/h class	7,000	9,000
Current	Running Current	A	0.25	0.25
Fan	Motor Type		BLDC	BLDC
	Fan Type		Turbo Fan	Turbo Fan
	Motor Output(W) x No. of Unit		43 x 1	43 x 1
	Air Flow Rate (H / M / L)	CMM	7.5 / 6.0 / 5.0	8.5 / 7.0 / 6.0
		CFM	265 / 212 / 177	300 / 265 / 230
	External Static Pressure	mmAq	-	-
	Capacitor	µF / Vac	-	-
Drive		Direct Drive	Direct Drive	
Coil	Row x Column x FPI		1R x 8C x 18	2R x 8C x 18
Dimensions (W x H x D)	Body	mm(inch)	570 x 214 x 570 (22-7/16 x 8-7/16 x 22-7/16)	570 x 214 x 570 (22-7/16 x 8-7/16 x 22-7/16)
	Decorative Panel	mm(inch)	700 x 22 x 700 (27-9/16 x 7/8 x 27-9/16)	700 x 22 x 700 (27-9/16 x 7/8 x 27-9/16)
Net Weight	Body	kg (lbs)	14.0 (30.9)	14.0 (30.9)
	Decorative Panel	kg (lbs)	3.0 (6.6)	3.0 (6.6)
Sound Level (H / M / L)		dB(A)+3	31 / 27 / 24	36 / 33 / 30
Piping	Liquid	mm (inch)	6.35 (1/4)	6.35 (1/4)
Connections	Gas	mm (inch)	9.52 (3/8)	9.52 (3/5)
	Drain(OD/ID)	mm(inch)	32.0(1-1/4) / 25.0(1)	32.0(1-1/4) / 25.0(1)
Safety Devices			Fuse, thermal protector for fan motor	Fuse, thermal protector for fan motor
Refrigerant			R410A	R410A
Refrigerant Control			EEV(in Outdoor unit)	EEV(in Outdoor unit)
Transmission Interunit Cable		No. x AWG	4C x 18	4C x 18

Note:

- Capacities are based on the following conditions:
 - Cooling: - Indoor Temperature 26.7°C(80°F) DB/19.4°C(67°F)
 - Outdoor Temperature 35°C(95°F) DB/23.9°C(75°F)
 - Heating: - Indoor Temperature 21.1°C(70°F) DB/15.6°C(60°F) WB
 - Outdoor Temperature 8.3°C(47°F) DB/6.1°C(43°F) WB
 - Piping Length - Interconnecting Piping Length 7.5m(24.6 ft.)
 - Level Difference of Zero
- Wiring cable size must comply with the applicable local and national code.
- The specification may be subject to change without prior notice for purpose of improvement.
- For more Capacity(*), refer to the combination table

Conversion Formula
kW = Btu/h class X 0.0002931
cfm = CMM x 35.3

Indoor unit type			Ceiling Cassette - 4way	
Model			AMNW12GTQA0[LMCN125HV]	AMNW18GTQA0[LMCN185HV]
Decoration Panel Name			PT-UQC	PT-UQC
Power Supply		V, Ø, Hz	208/230, 1, 60	208/230, 1, 60
Capacity(*)		Btu/h class	12,000	18,000
Current	Running Current	A	0.25	0.25
Fan	Motor Type		BLDC	BLDC
	Fan Type		Turbo Fan	Turbo Fan
	Motor Output(W) x No. of Unit		43 x 1	43 x 1
	Air Flow Rate (H / M / L)	CMM	9.5 / 8.0 / 7.0	13.0 / 12.0 / 11.0
		CFM	335 / 283 / 247	459 / 424 / 388
	External Static Pressure	mmAq	-	-
	Capacitor	µF / Vac	-	-
Drive		Direct Drive	Direct Drive	
Coil	Row x Column x FPI		2R x 8C x 18	2R x 10C x 18
Dimensions (W x H x D)	Body	mm(inch)	570 x 214 x 570 (22-7/16 x 8-7/16 x 22-7/16)	570 x 256 x 570 (22-7/16 x 10-3/32 x 22-7/16)
	Decorative Panel	mm(inch)	700 x 22 x 700 (27-9/16 x 7/8 x 27-9/16)	700 x 22 x 700 (27-9/16 x 7/8 x 27-9/16)
Net Weight	Body	kg (lbs)	14.0 (30.9)	15.0 (33.1)
	Decorative Panel	kg (lbs)	3.0 (6.6)	3.0 (6.6)
Sound Level (H / M / L)		dB(A)+3	38/ 35/ 32	38/ 37/ 34
Piping	Liquid	mm (inch)	6.35 (1/4)	6.35 (1/4)
Connections	Gas	mm (inch)	9.52 (3/8)	12.7 (1/2)
	Drain(OD/ID)	mm(inch)	32.0(1-1/4) / 25.0(1)	32.0(1-1/4) / 25.0(1)
Safety Devices			Fuse, thermal protector for fan motor	Fuse, thermal protector for fan motor
Refrigerant			R410A	R410A
Refrigerant Control			EEV(in Outdoor unit)	EEV(in Outdoor unit)
Transmission Interunit Cable		No. x AWG	4C x 18	4C x 18

Note:

1. Capacities are based on the following conditions:

- Cooling: - Indoor Temperature 26.7°C(80°F) DB/19.4°C(67°F)
- Outdoor Temperature 35°C(95°F) DB/23.9°C(75°F)
- Heating: - Indoor Temperature 21.1°C(70°F) DB/15.6°C(60°F) WB
- Outdoor Temperature 8.3°C(47°F) DB/6.1°C(43°F) WB
- Piping Length - Interconnecting Piping Length 7.5m(24.6 ft.)
- Level Difference of Zero

2. Wiring cable size must comply with the applicable local and national code.

3. The specification may be subject to change without prior notice for purpose of improvement.

4. For more Capacity(*),refer to the combination table

Conversion Formula
kW = Btu/h class X 0.0002931
cfm = CMM x 35.3

2. Piping Diagrams

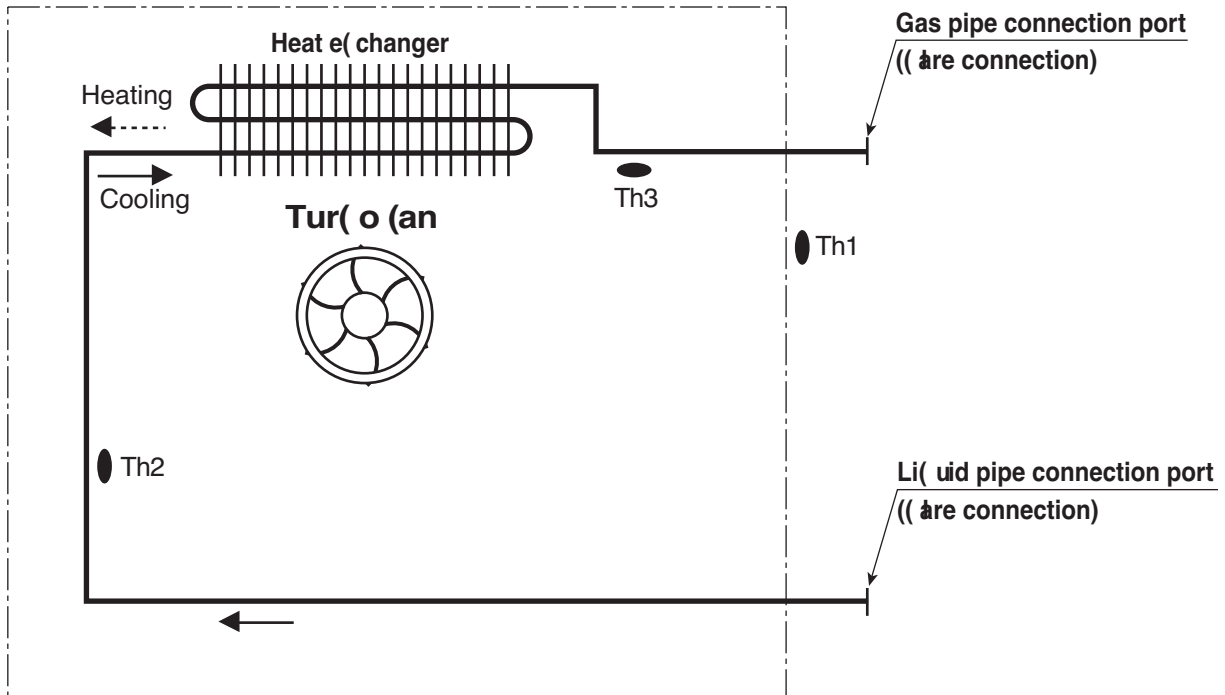

LOC.	Description	PCB Connector
Th1	Thermistor for suction air temperature	CN_ROOM
Th2	Thermistor for evaporator inlet temperature	CN_PIPE/IN
Th3	Thermistor for evaporator outlet temperature	CN_PIPE/OUT

3. Wiring Diagrams

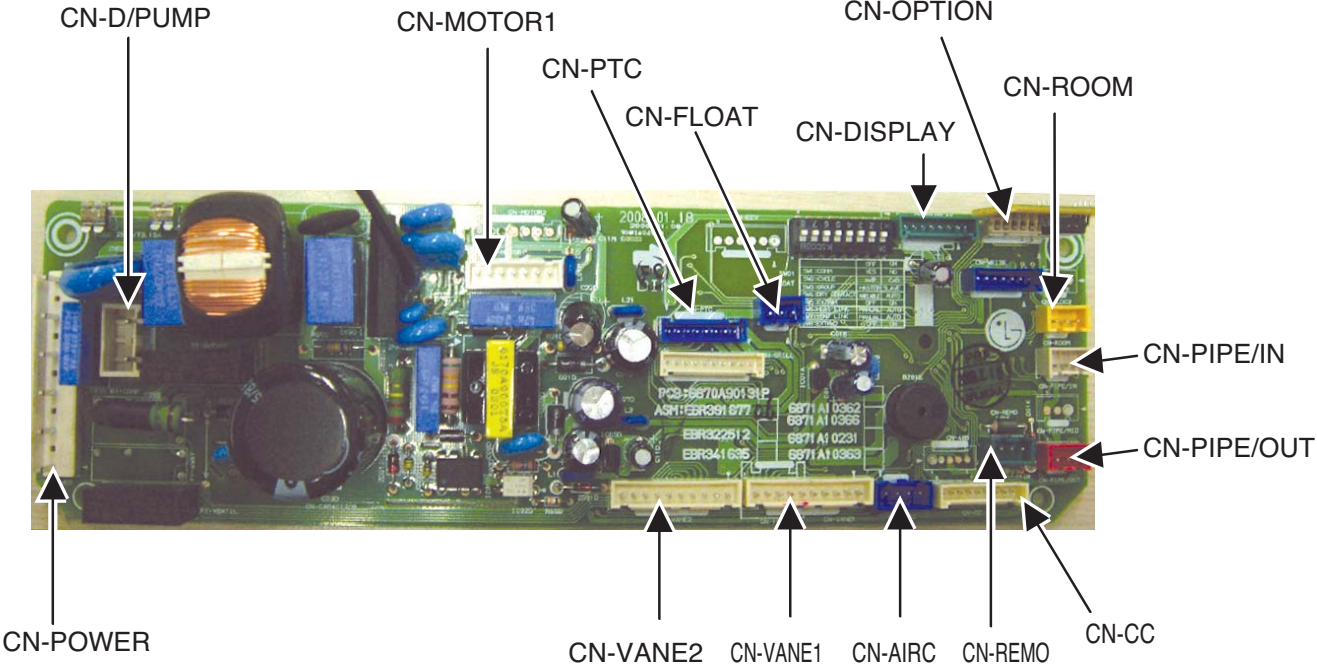
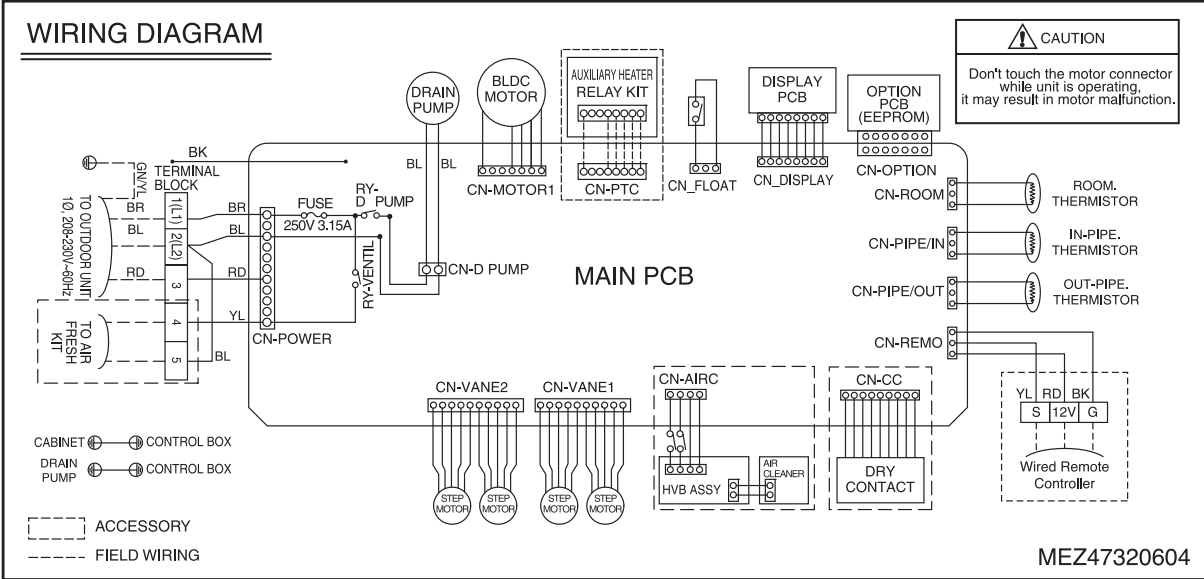

4. Exploded View

• TR Chassis

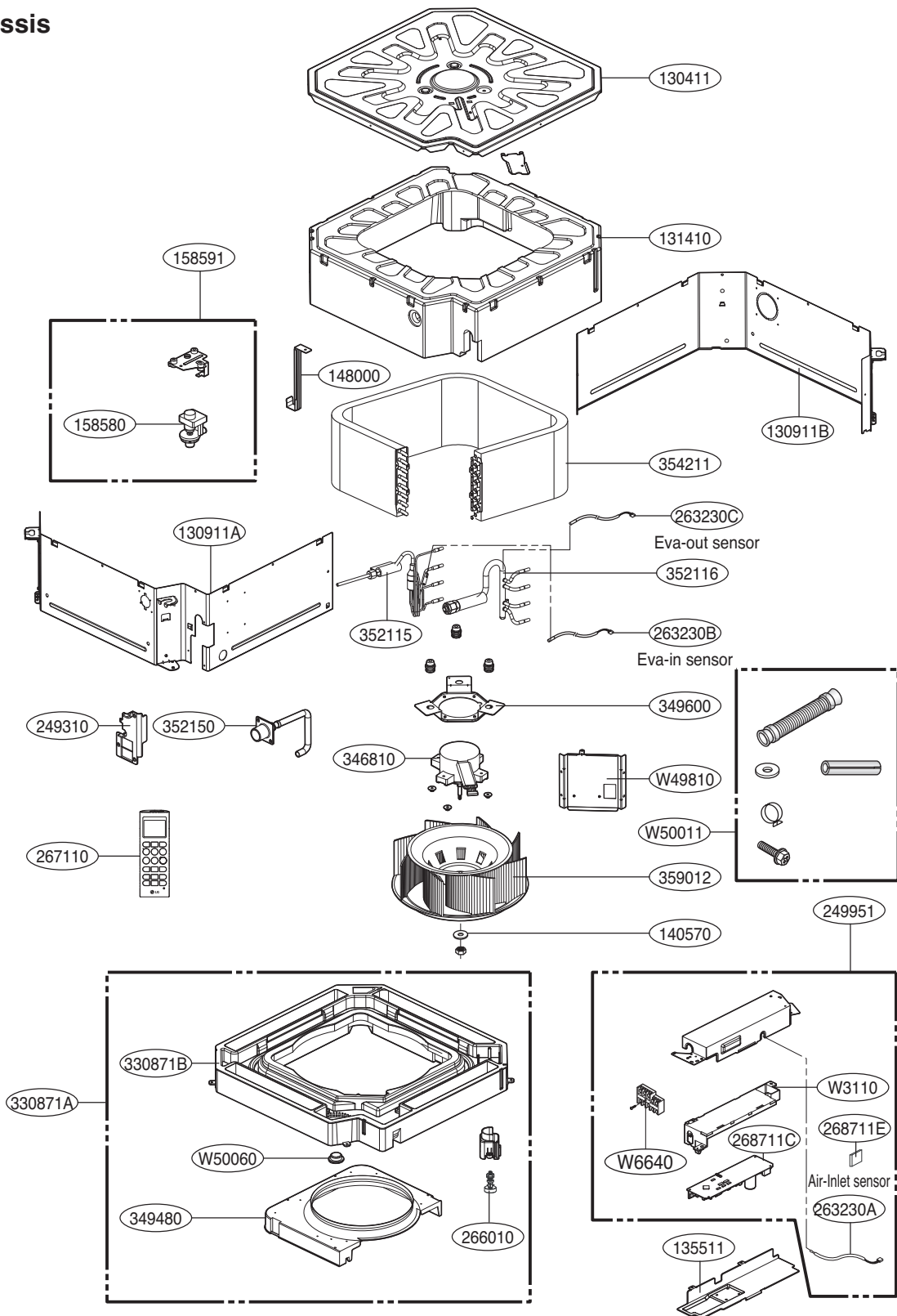

Note) * Please ensure GCSC since the replacement parts may be changed depending upon the buyer's request.
Please check the correct parts in View RPL(Replacement Part List) on GCSC.
(GCSC Website <http://biz.lgservice.com>.)

• TQ Chassis

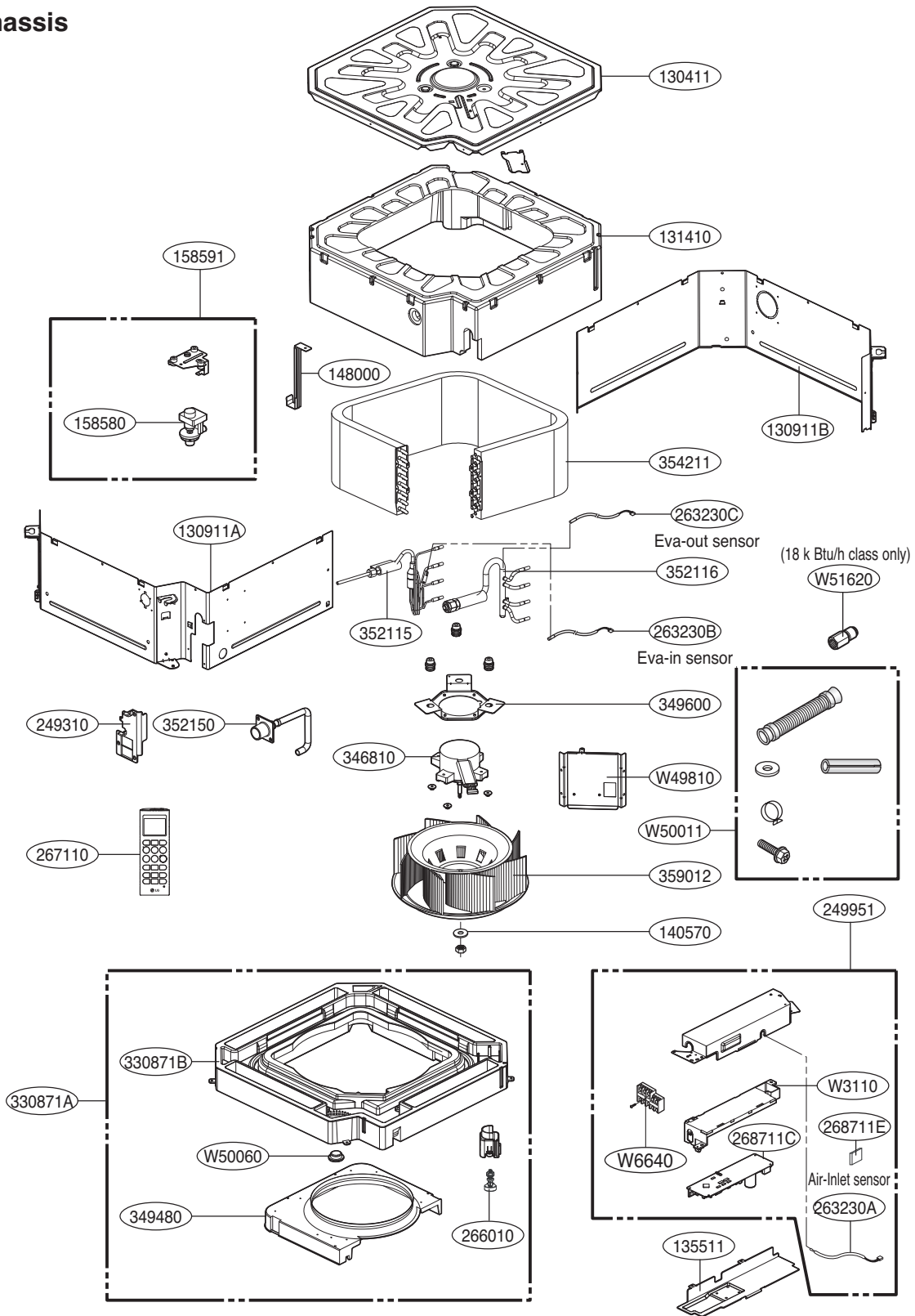

Note) * Please ensure GCSC since the replacement parts may be changed depending upon the buyer's request.
 Please check the correct parts in View RPL(Replacement Part List) on GCSC.
 (GCSC Website <http://biz.Lgservice.com>,)

Front Panel (Accessory)

• Model : PT-UQC

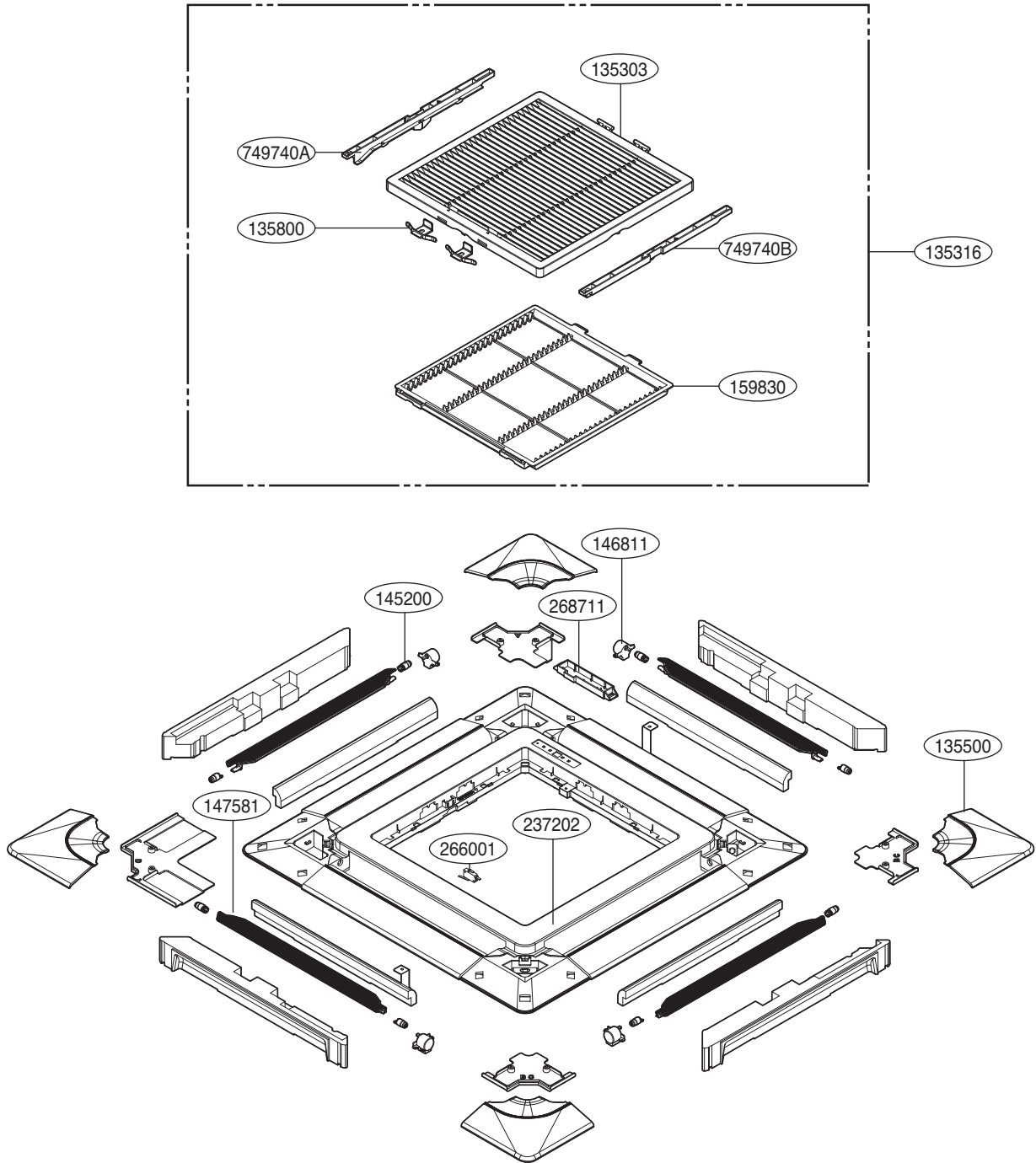

Note) * Please ensure GCSC since the replacement parts may be changed depending upon the buyer's request.
Please check the correct parts in View RPL(Replacement Part List) on GCSC.
(GCSC Website <http://biz.Lgservice.com>.)



P/NO : MFL61777609

JANUARY, 2014