

This Owner's Manual is provided and hosted by [Appliance Factory Parts](#).



# Grand Hall OD3211BNG Owner's Manual

[Shop genuine replacement parts for Grand Hall  
OD3211BNG](#)



[Find Your Grand Hall Grill Parts - Select From 203 Models](#)

----- Manual continues below -----

# grandhall

Liquid Propane Gas (LPG) Grill  
Models OD2611BLP & OD3211BLP  
Natural Gas (NG) Grill  
Models OD2611BNG & OD3211BNG

## Operator's Manual

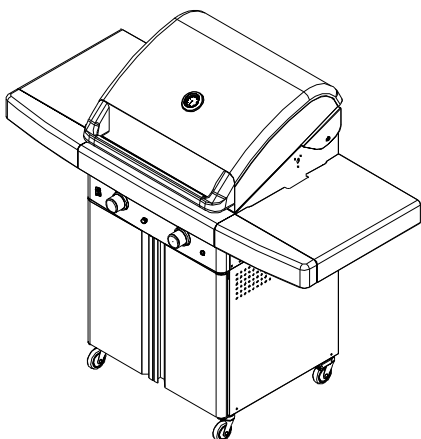

OD2611BLP/NG

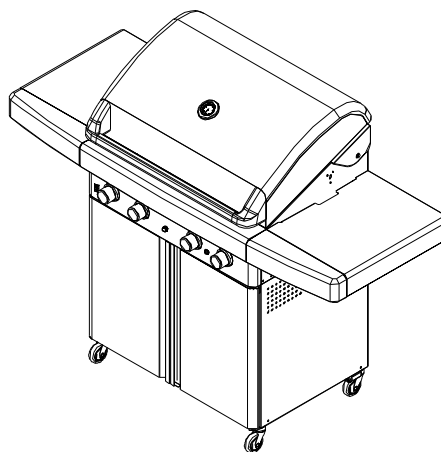

OD3211BLP/NG

### FREE HELP FROM THE GRILL EXPERTS

Grand Hall is the expert on this product and trained to help you with:

- Y Assembly Questions
- Y Grill Operation
- Y Replacement of Damaged or Missing parts

visit [www.grandhall.com](http://www.grandhall.com) or call:

1-877-934-7455

Monday - Friday 8:00am-4:30pm CST

### IMPORTANT:

#### Y NOTE TO ASSEMBLER/INSTALLER:

Leave this manual with the consumer.

#### Y NOTE TO CONSUMER:

Keep this manual for future reference.

#### Y RECORD YOUR SERIAL # \_\_\_\_\_

(see silver CSA label on Left Door Panel)



### WARNING



- Y Failure to comply with these instructions could result in a fire or explosion that could cause serious bodily injury, death or property damage.
- Y Whether this grill was assembled by you or someone else, you must read this entire manual before using your grill to ensure the grill is properly assembled, installed and maintained.
- Y **Use your grill at least 3 feet away from any wall or surface.** Use your grill at least **3 feet away** from combustible objects that can melt or catch fire such as vinyl or wood siding, fences and overhangs or sources of ignition including pilot lights on water heaters and live electrical appliances.
- Y **THIS GAS APPLIANCE IS DESIGNED FOR OUTDOOR USE ONLY.**
- Y **Never** use your gas grill in a garage, porch, shed, breezeway or any other enclosed area.
- Y **Never** obstruct the flow of ventilation air around your gas grill housing.
- Y **Never** disconnect the gas regulator or any gas fitting while your grill is lit. A lit grill can ignite leaking gas and cause a fire or explosion which could result in property damage, personal injury or death.

## Table of Contents

Primary Safety Warnings.....	1-3
Pre-Assembly Instructions.....	3
Part Diagrams and Lists.....	4-11
Assembly Instructions.....	12-17
Use & Care Instructions:	
• Gas Safety and Leak Tests.....	18-20
• Natural Gas Connection.....	21
• Lighting & Fuel Gauge Instructions...	22-23
• Troubleshooting.....	24
• Transformer Instruction.....	25
Cleaning and Maintenance.....	26
Cooking Guide.....	A1-A5
Frequently Asked Questions.....	A6-A7
Warranty Terms.....	Back Cover

### Registered and unregistered Trademarks held by Grand Hall include the following:

Grand Hall and design®, DS Grill and design®, Crossray™ Lateral Infrared Burner Technology, Command Flame®, Smooth Start® Electronic Ignition System, Ceramic Savor Plates®, Sear-zzler®, Stainless Clad Therma-Core® Cooking Grids, Grand Café and design®, Grand Mark and design®, Grand Chef and design®, Grand Royale and design®, Globe Café and design®, Urban Café and design®, Smokeless Grill and design®.

### Patents held by Grand Hall include the following:

The Crossray Burner System by Grand Hall is covered by Australian Patent No. 2006100635, Chinese Patent No. 960361, European Patent No. 1886606, French Patent 0607231, German Patent No. 20 2006 012 212.5, U.K Patent GB2440714, and U.S. Patent 7,475,632.

©2008 Grand Hall. All Rights Reserved.



## WARNING

- This appliance, when installed, must be electrically grounded in accordance with local codes or, in the absence of local codes, with the *National Electrical Code, ANSI/NFPA 70*, or the *Canadian Electrical Code, CSA C22.1*.
- Keep any electrical supply cord and the fuel supply hose away from any heated surfaces.



## WARNING

**Never** cover or wrap the Cooking Grids, bottom of the Grill Bowl, Grease Receptacle, or Grease Draining Tray with aluminum foil or any other material that will absorb grease.



## WARNING

1. **Do not store or use gasoline or other flammable liquids or vapors in the vicinity of this or any other appliances.**
2. **An LP cylinder not connected for use shall not be stored in the vicinity of this or any other appliance.**



## WARNING

- LPG models must be used with Liquid Propane Gas and the regulator assembly supplied. Natural Gas models must be used with Natural Gas only. Any attempt to convert the grill from one fuel type to another is extremely hazardous and will void the warranty.
- Keep gas regulator hose away from hot grill surfaces and dripping grease. Avoid unnecessary twisting of hose. Visually inspect hose prior to each use for cuts, cracks, excessive wear or other damage. If the hose appears damaged do not use the gas grill. Call 1-877-934-7455 for a certified replacement hose.
- **California Proposition 65**  
Combustion byproducts produced when using this product contain chemicals known to the State of California to cause cancer, birth defects, or other reproductive harm.  
  
Brass components on the grill, such as hose fittings, propane cylinder valves (sold separately) and burner valve stems, contain lead which is known to the State of California to cause cancer, birth defects, or other reproductive harm.
- **Never use charcoal** or lighter fluid in this gas grill. Failure to comply with these instructions could result in a grease fire or explosion that could cause serious bodily injury, death or property damage.
- The Grease Draining Tray must be visually inspected before each grill use. Remove any grease and wash Grease Draining Tray and Grease Receptacle with a mild soap and warm water solution. **Failure to comply with these instructions could result in a grease fire or explosion that could cause serious bodily injury, death or property damage.**



## DANGER

**If you smell gas:**

1. **Shut off gas to the appliance.**
2. **Extinguish any open flame.**
3. **Open lid.**
4. **If odor continues, keep away from the appliance and immediately call your gas supplier or your fire department.**

## Pre-Assembly Instructions For Your Safety

Congratulations on your selection of one of the finest outdoor kitchen appliances available. Your Grill is equipped with the unique Crossray Infrared Cooking System® by Grand Hall, which offers restaurant style grilling performance.

Infrared grilling technology cooks the food directly (and not the air around it) which offers many advantages over conventional grilling systems:

- MORE FLAVORFUL FOOD** as the intense heat sears the food and locks in the juices while also cooking it faster which usually means more succulence.
- FEWER FLAREUPS** as the higher infrared heat vaporizes more drippings which also adds natural flavoring to your food.
- MORE EFFICIENCY AND CONVENIENCE** as the higher heat means shorter cooking times, more fuel efficiency and easier year round grilling.

To begin your "restaurant quality" grilling, become familiar with all of the cooking elements of your Grand Hall Grill lighting and operating instructions.

US Patented No.: 7,475,632  
European Patent No.: 1886606  
Australia Patent No.: 2006100635  
Germany Patent No.: 202006012212.5  
France Patent No.: 0607231  
UK Patent No.: GB2440714  
China Patent No.: 960361

### PRE-ASSEMBLY

Read and perform the following pre-assembly instructions:

- Tools Required for Assembly:**
  - Protective work gloves
  - Protective eyewear
  - Phillips Head Screwdriver
- You will need assistance from another person to handle the grill head and other large, heavy parts.
- Open lid of shipping carton. Remove top sheet of cardboard and packing materials. Lay cardboard sheet on floor and use as a work surface to protect floor and grill parts from scratches.
- You may slice the carton front corners with a utility knife to lay open the carton front panel. This allows you to raise the Lid and remove the components packed inside, making it easier to lift.
- Use the Hardware and Part Diagrams to ensure all items are included and free of damage.
- Do not assemble or operate the grill if it appears damaged. If there are damaged or missing parts when you unpack the shipping box or you have questions during the assembly process call **1-877-934-7455 M-F 8AM-4:30PM CST** for assistance.

### Grill Installation Codes

The installation must conform with local codes or, in the absence of local codes, with either the National Fuel Gas Code, ANSI Z223.1/NFPA 54, Natural Gas and Propane Installation Code, CSA B149.1, or Propane Storage and Handling Code, B149.2.

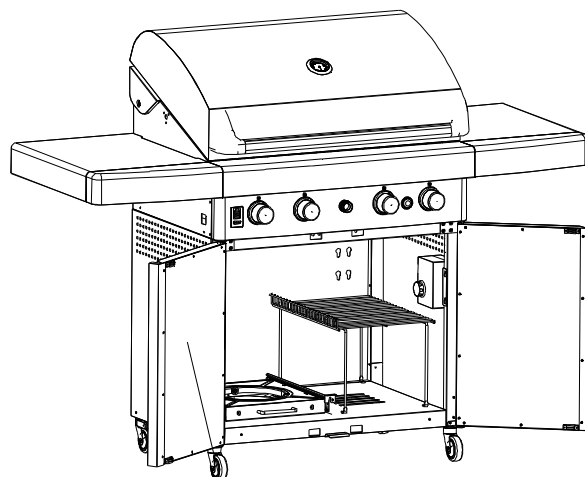

CSA Label located on the inside panel of the left door

## Hardware Pack Parts List for Models OD2611BLP/NG

PART #	PART DESCRIPTION	QTY	PURPOSE OF PART
P06006081A	Hardware Pack	1	For use in assembly of Model OD2611BLP
P06006082A	Hardware Pack	1	For use in assembly of Model OD2611BNG
S182G04061	Pan Head Screw 1/4"x3/8"	4	Install Caster Seats to the Cart Side Panels
S182G03061	Pan Head Screw 3/16"x3/8"	8	
S182G03061	Pan Head Screw 3/16"x3/8"	4	Install Cart Side Panels to Cart Bottom Panel
S182G04061	Pan Head Screw 1/4"x3/8"	8	
S182G03061	Pan Head Screw 3/16"x3/8"	4	Install Lower Door Hinge Brackets
S182G03061	Pan Head Screw 3/16"x3/8"	2	Install Door Guide Plate
S182G03061	Pan Head Screw 3/16"x3/8"	6	Install Cart Rear Panel
S182G0306A	Pan Head Screw 3/16"x3/8"	6	Install Cart Top Panel
S182G0406A	Pan Head Screw 1/4"x3/8"	4	Install Tank Pull-out Tray Assembly (For OD2611BLP model)
P05515130L	Wrench	1	Install Casters
S182G03161	Pan Head Screw 3/16"x1"	4	Install Grill Bowl
S182G03061	Pan Head Screw 3/16"x3/8"	1	LP Regulator Hose Holder (For OD2611BLP model)
S182G0306A	Pan Head Screw 3/16"x3/8"	2	Install Control Box
S182G03061	Pan Head Screw 3/16"x3/8"	4	Install Cart Front Bracket
S182G03061	Pan Head Screw 3/16"x3/8"	8	Install Upper Door Hinge Brackets
S182G03161	Pan Head Screw 3/16"x1"	8	Install Side Shelf Brackets
S182G03061	Pan Head Screw 3/16"x3/8"	8	Install Side Shelves
S182G03081	Pan Head Screw 3/16"x1/2"	2	

## Hardware Pack Diagram List for Models OD2611BLP/NG



Pan Head Screw 1/4"x3/8"  
Qty. 4  
(For OD2611BLP model)  
Part # S182G0406A



Pan Head Screw 3/16"x3/8"  
Qty. 44 (NG models)  
Qty. 45 (LPG models)  
Part # S182G03061



Pan Head Screw 3/16"x1"  
Qty. 12  
Part # S182G03161



Pan Head Screw 3/16"x1/2"  
Qty. 2  
Part # S182G03081



Pan Head Screw 1/4"x3/8"  
Qty. 12  
Part # S182G04061

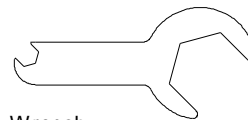

Wrench  
Qty. 1  
Part # P05515130L



Pan Head Screw 3/16"x3/8"  
Qty. 8  
Part # S182G0306A

\* One Battery/AA and Six Batteries/AAA included in the Hardware Pack for LPG.

\* One Battery/AA and Four Batteries/AAA included in the Hardware Pack for NG.

## Hardware Pack Parts List for Models OD3211BLP/NG

PART #	PART DESCRIPTION	QTY	PURPOSE OF PART
P06006083A	Hardware Pack	1	For use in assembly of Model OD3211BLP
P06006084A	Hardware Pack	1	For use in assembly of Model OD3211BNG
S182G04061	Pan Head Screw 1/4"x3/8"	4	Install Caster Seats to the Cart Side Panels
S182G03061	Pan Head Screw 3/16"x3/8"	8	
S182G03061	Pan Head Screw 3/16"x3/8"	4	Install Cart Side Panels to Cart Bottom Panel
S182G04061	Pan Head Screw 1/4"x3/8"	8	
S182G03061	Pan Head Screw 3/16"x3/8"	4	Install Lower Door Hinge Brackets
S182G03061	Pan Head Screw 3/16"x3/8"	2	Install Door Guide Plate
S182G03061	Pan Head Screw 3/16"x3/8"	6	Install Cart Rear Panel
S182G0306A	Pan Head Screw 3/16"x3/8"	6	Install Cart Top Panel
S182G0406A	Pan Head Screw 1/4"x3/8"	4	Install Tank Pull-out Tray Assembly (For OD3211BLP model)
P05515130L	Wrench	1	Install Casters
S182G03081	Pan Head Screw 3/16"x1/2"	4	Install Spice Shelf
S182G03161	Pan Head Screw 3/16"x1"	4	Install Grill Bowl
S182G03061	Pan Head Screw 3/16"x3/8"	1	LP Regulator Hose Holder(For OD3211BLP model)
S182G0306A	Pan Head Screw 3/16"x3/8"	2	Install Control Box
S182G03061	Pan Head Screw 3/16"x3/8"	4	Install Cart Front Bracket
S182G03061	Pan Head Screw 3/16"x3/8"	8	Install Upper Door Hinge Brackets
S182G03161	Pan Head Screw 3/16"x1"	8	Install Side Shelf Brackets
S182G03061	Pan Head Screw 3/16"x3/8"	8	Install Side Shelves
S182G03081	Pan Head Screw 3/16"x1/2"	2	

## Hardware Pack Diagram List for Models OD3211BLP/NG



Pan Head Screw 1/4"x3/8"  
Qty. 4  
(for OD3211BLP model)  
Part # S182G0406A



Pan Head Screw 3/16"x3/8"  
Qty. 44 (NG models)  
Qty. 45 (LPG models)  
Part # S182G03061



Pan Head Screw 3/16"x1"  
Qty. 12  
Part # S182G03161



Pan Head Screw 3/16"x1/2"  
Qty. 6  
Part # S182G03081



Pan Head Screw 1/4"x3/8"  
Qty. 12  
Part # S182G04061

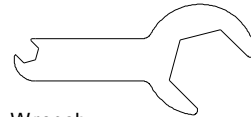

Wrench  
Qty. 1  
Part # P05515130L



Pan Head Screw 3/16"x3/8"  
Qty. 8  
Part # S182G0306A

- \* One Battery/AA and Six Batteries/AAA included in the Hardware Pack for LPG.
- \* One Battery/AA and Four Batteries/AAA included in the Hardware Pack for NG.

# Parts Diagram for Models OD2611BLP/NG

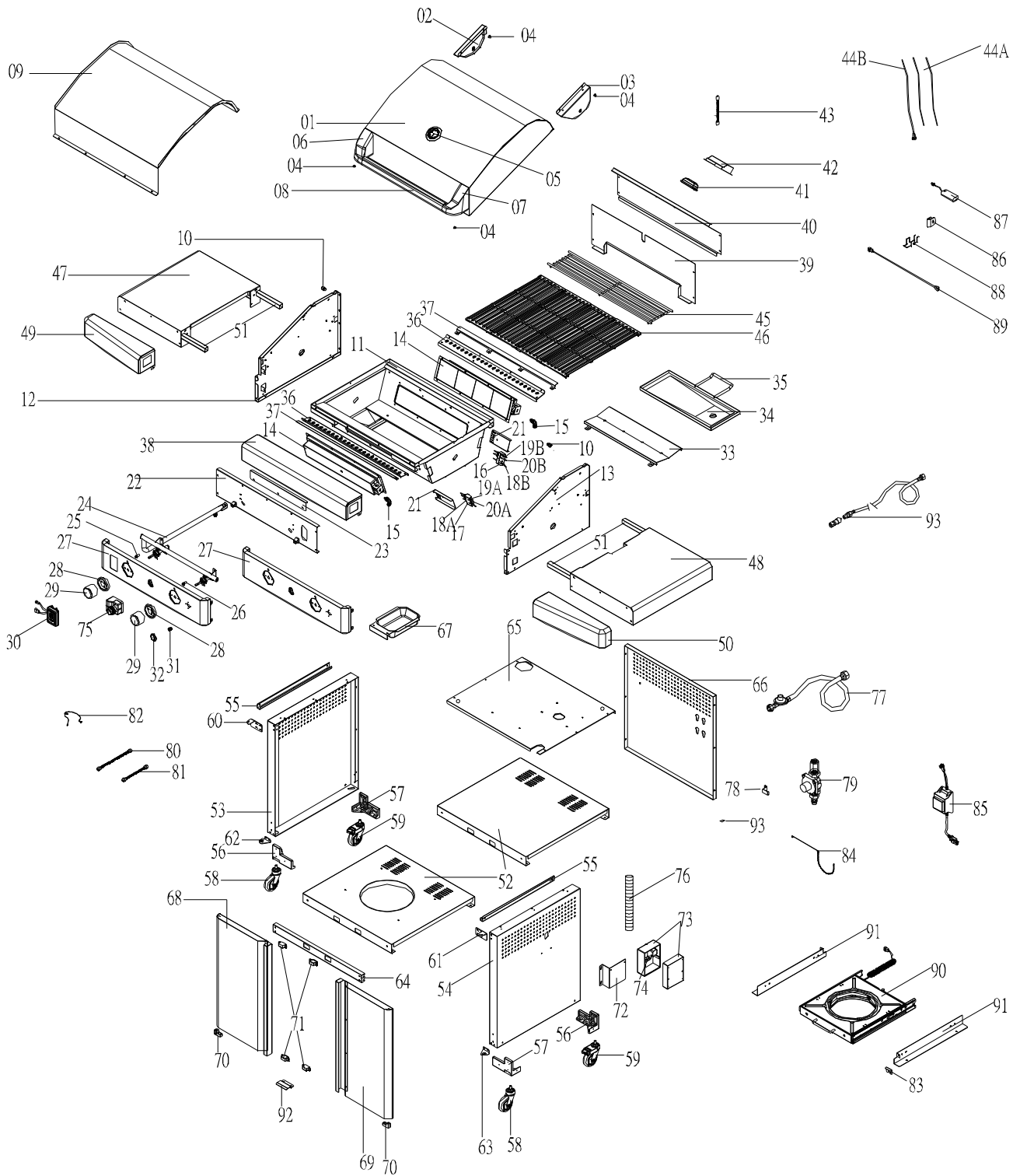

## Parts List for Models OD2611BLP/NG

KEY	DESCRIPTION	OD2611BLP/NG PART#	QTY
01	Lid Assembly	P0014633A4	1
02	Lid Assembly Bracket,Left	P033200074	1
03	Lid Assembly Bracket,Right	P033200084	1
04	Protective Pad	P05518002I	4
05	Temperature Gauge	P00601381A	1
06	Lid Handle Bracket, Left	P00307058E	1
07	Lid Handle Bracket, Right	P00308058E	1
08	Lid Handle	P00215037H	1
09	Lid Trim Plate	P0014635QJ	1
10	Lid Hinge with Nut	P05501136L	2
11	Grill Bowl	P0071368JA	1
12	Bowl Side Panel, Left	P0076113E4	1
13	Bowl Side Panel, Right	P0076213E4	1
14	Infrared Burner Assembly	P02005025F	2
15	Extension Fitting for Manifold With Orifice (LPG)	P06539030A	2
	Extension Fitting for Manifold With Orifice (NG)	P06539031A	2
16	Thermocouple Bracket, Rear	P03327083C	1
17	Thermocouple Bracket, Front	P03327082C	1
18A	Electrode, Front	P02618056A	1
18B	Electrode, Rear	P02618057A	1
19A	Thermocouple for LED Light, Front	P05305066B	1
19B	Thermocouple for LED Light, Rear	P05305065B	1
20A	Thermocouple for Gas Valve, Front	P05305055B	1
20B	Thermocouple for Gas Valve, Rear	P05305061B	1
21	Thermocouple Protector	P03343019C	2
22	Control Panel Heat Shield	P03007206B	1
23	Control Panel Heat Shield Bracket	P0300613FD	1
24	Gas Valve/Manifold Assembly (LPG)	Y0060677	1
	Gas Valve/Manifold Assembly (NG)	Y0060678	1
25	LED Light with Wire - A	P02615159A	1
26	LED Light with Wire - B	P02615167A	1
27	Control Panel (LPG)	P02913763S	1
	Control Panel (NG)	P02913763F	1
28	Control Knob Seat	P03439014A	2
29	Control Knob	P03436053V	2
30	Fuel Gauge Display	P05310041B	1
31	Switch for Lamp	P05360001B	1
32	Switch Cover for Lamp	P05382004P	1
33	Grease Draining Tray Heat Shield	P06903069A	1
34	Grease Draining Tray	P02717615B	1
35	Grease Draining Tray Handle	P00213032H	1
36	Grease Shield, Lower	P06902129C	2
37	Grease Shield, Upper	P06902128C	2
38	Bowl Front Trim Plate Assembly	P02913471S	1
39	Bowl Panel, Rear/Lower	P0073747B4	1
40	Bowl Panel, Rear/Upper	P0073745BC	1
41	Lamp,12V, 10W	P05352012B	1
42	Lamp Cover	P05352013E	1
43	Lamp Wire Set Protector	P055330103	1
44A	Lamp Wire Set	P05352017B	1
44B	Connection Wire for Transformer	P05352019A	1
45	Cooking Rack/Secondary	P015140222	1
46	Cooking Grid	P01615038H	4
47	Side Shelf, Left	P01102057F	1
48	Side Shelf, Right	P01103047F	1
49	Side Shelf Trim Plate, Left	P07503023A	1
50	Side Shelf Trim Plate, Right	P07502031A	1

## Parts List for Models OD2611BLP/NG

KEY	DESCRIPTION	OD2611BLP/NG PART#	QTY
51	Side Shelf Bracket	P03342015L	4
52	Cart Panel, Bottom (LPG)	P01001104L	1
	Cart Panel, Bottom (NG)	P01001105L	1
53	Cart Panel, Left	P07605035G	1
54	Cart Panel, Right	P07606038G	1
55	Bowl Bracket	P03315026F	2
56	Caster Seat, Left Front & Right Rear	P05327064H	2
57	Caster Seat, Right Front & Left Rear	P05327065H	2
58	Caster, 3" without Brake	P05112026A	2
59	Caster, 3" with Brake	P05112027A	2
60	Door Hinge Bracket, Left/Upper	P03313031F	1
61	Door Hinge Bracket, Right/Upper	P03313032F	1
62	Door Hinge Bracket, Left/Lower	P03313033F	1
63	Door Hinge Bracket, Right/Lower	P03313034F	1
64	Cart Bracket, Front	P03305073F	1
65	Cart Panel, Top	P01003054D	1
66	Cart Panel, Rear	P07702113D	1
67	Grease Receptacle	P02701305G	1
68	Door Assembly, Left	P043050694	1
69	Door Assembly, Right	P043060694	1
70	Door Hinge	Y0550002	2
71	Door Magnet	P05523056L	4
72	Control Box Bracket	P03343018D	1
73	Control Box	P05545006M	1
74	LED Light Controller	P05357021B	1
75	Electric Ignitor, 2-Port	P02502392C	1
76	Electric Wire Protector	P055330043	1
77	Regulator with Hose Assembly (LPG)	P03603049A	1
78	LP Regulator Hose Holder	P055360034	1
79	Regulator (NG)	P03614005C	1
80	Connection Hose - Long	P03702037D	1
81	Connection Hose - Short	P03702039D	1
82	Electrode Wire Set	P02627013A	1
83	Bolt for Tank Pull-out Tray Assembly	P055101424	1
84	Lighting Stick	P05507140M	1
85	Transformer	P05374015B	1
86	Wire Clip	P055530023	3
87	Battery Box	P05301012B	1
88	Battery Box Bracket	P03311057K	1
89	Connection Wire for Tank Pull-out Tray	P02616076A	1
90	Tank Pull-out Tray Assembly	Y0530018	1
91	Tank Pull-out Tray Bracket	P03327110F	2
92	Door Guide Plate	P05510137A	1
93	Hose, 12 FT. (NG) 3/8"ID (Optional)	P03703001A	1
	Hardware Pack (LPG)	P06006081A	1
	Hardware Pack (NG)	P06006082A	1
	Operator's Manual	P80151127A	1

For the repair or replacement parts you need:  
Call 1-877-934-7455 M-F 8:00AM-4:30PM CST

To obtain the correct replacement parts for your gas grill, please refer to the part numbers in this parts list. The following information is required to ensure you receive the correct parts:

1. Model and Serial Number (see CSA label on grill)
2. Part Number
3. Part Description
4. Quantity of parts needed

**Important:** Use only Grand Hall replacement parts. The use of any part that is not a Grand Hall replacement part can be dangerous and will also void your product warranty. Keep this Operator's Manual for convenient referral and for part replacement.

# Parts Diagram for Models OD3211BLP/NG

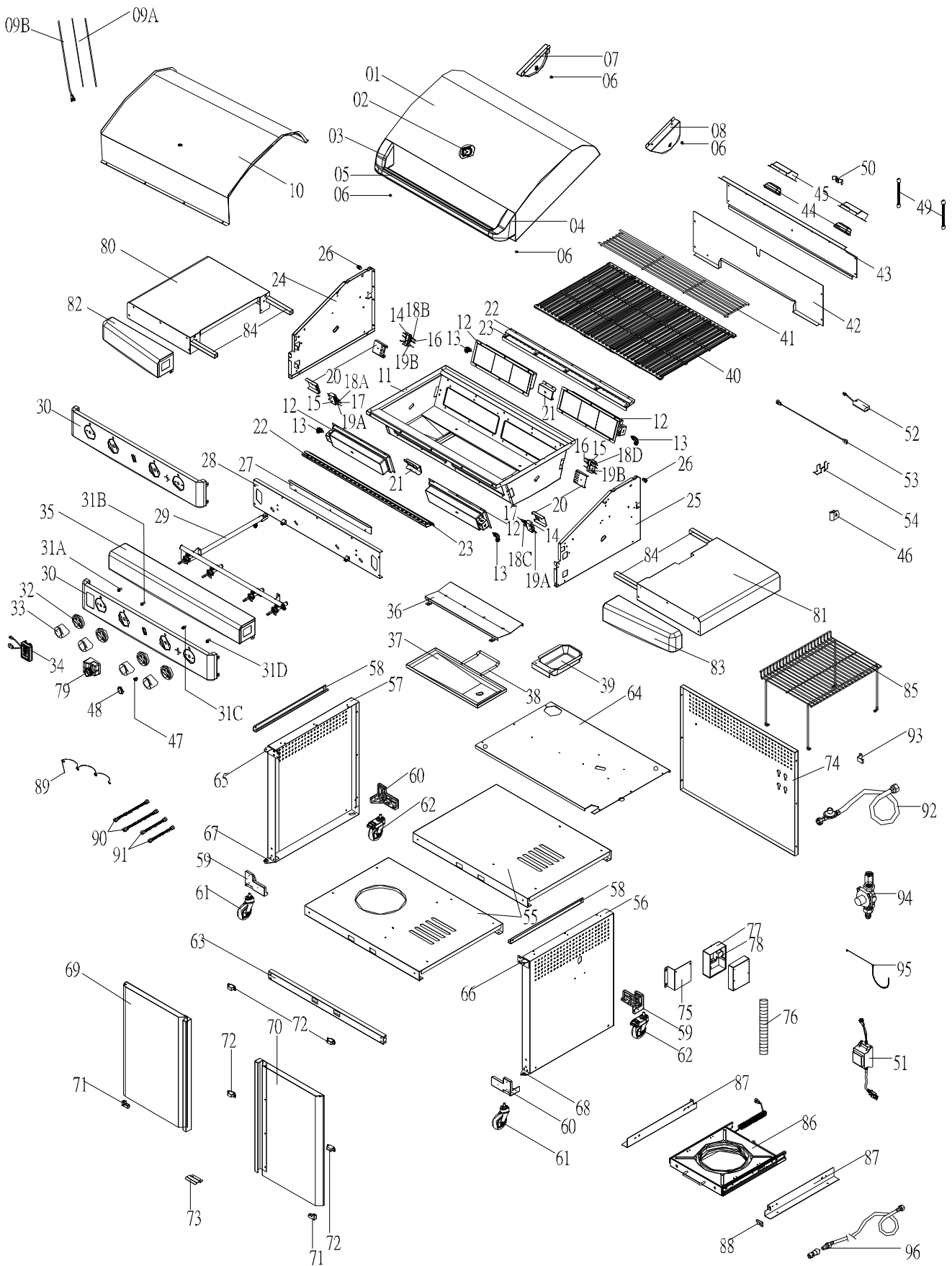

## Parts List for Models OD3211BLP/NG

KEY	DESCRIPTION	OD3211BLP/NG PART#	QTY
01	Lid Assembly	P0014731A4	1
02	Temperature Gauge	P00601381A	1
03	Lid Handle Bracket, Left	P00307058E	1
04	Lid Handle Bracket, Right	P00308058E	1
05	Lid Handle	P00215036H	1
06	Protective Pad	P05518002I	4
07	Lid Assembly Bracket, Left	P033200074	1
08	Lid Assembly Bracket, Right	P033200084	1
09A	Lamp Wire Set	P05352018A	1
09B	Connection Wire for Transformer	P05352019A	1
10	Lid Trim Plate	P0014735QJ	1
11	Grill Bowl	P0071367JA	1
12	Infrared Burner Assembly	P02005024F	4
13	Extension Fitting for Manifold With Orifice (LPG)	P06539032A	4
	Extension Fitting for Manifold With Orifice (NG)	P06539033A	4
14	Thermocouple Bracket, Right Front/Left Rear	P03327082C	2
15	Thermocouple Bracket, Left Front/Right Rear	P03327083C	2
16	Thermocouple for Gas Valve, Long	P05305055B	2
17	Thermocouple for Gas Valve, Short	P05305054B	2
18A	Thermocouple for LED Light, Left Front	P05305056B	1
18B	Thermocouple for LED Light, Left Rear	P05305057B	1
18C	Thermocouple for LED Light, Right Front	P05305058B	1
18D	Thermocouple for LED Light, Right Rear	P05305059B	1
19A	Electrode, Front	P02618056A	2
19B	Electrode, Rear	P02618057A	2
20	Thermocouple Protector	P03343017C	4
21	Cross Lighting Channel	P02212377A	2
22	Grease Shield, Lower	P06902127C	2
23	Grease Shield, Upper	P06902126C	2
24	Bowl Side Panel, Left	P0076113E4	1
25	Bowl Side Panel, Right	P0076213E4	1
26	Lid Hinge with Nut	P05501136L	2
27	Control Panel Heat Shield Bracket	P0300612FD	1
28	Control Panel Heat Shield	P03008186B	1
29	Gas Valve/Manifold Assembly (LPG)	Y0060679	1
	Gas Valve/Manifold Assembly (NG)	Y0060680	1
30	Control Panel (LPG)	P0291565GI	1
	Control Panel (NG)	P0291566GI	1
31A	LED Light with Wire - A	P02615155A	1
31B	LED Light with Wire - B	P02615156A	1
31C	LED Light with Wire - C	P02615157A	1
31D	LED Light with Wire - D	P02615158A	1
32	Control Knob Seat	P03439014A	4
33	Control Knob	P03436053V	4
34	Fuel Gauge Display	P05310041B	1
35	Bowl Front Trim Plate Assembly	P02915301S	1
36	Grease Draining Tray Heat Shield	P06903069A	1
37	Grease Draining Tray	P02717615B	1
38	Grease Draining Tray Handle	P00213032H	1
39	Grease Receptacle	P02701305G	1
40	Cooking Grid	P01615038H	5
41	Cooking Rack/Secondary	P015160282	1
42	Bowl Panel, Rear/Lower	P0073748B4	1
43	Bowl Panel, Rear/Upper	P0073749B4	1
44	Lamp,12V, 10W	P05352012B	2
45	Lamp Cover	P05352013E	2
46	Wire Clip	P055530023	3

## Parts List for Models OD3211BLP/NG

KEY	DESCRIPTION	OD3211BLP/NG PART#	QTY
47	Switch for Lamp	P05360001B	1
48	Switch Cover for Lamp	P05382004P	1
49	Lamp Wire Set Protector	P055330103	2
50	Lamp Wire Set Protector Bracket	P03328079C	1
51	Transformer	P05374015B	1
52	Battery Box	P05301012B	1
53	Connection Wire for Tank Pull-out Tray	P02616076A	1
54	Battery Box Bracket	P03348004K	1
55	Cart Panel, Bottom (LPG)	P01003063L	1
	Cart Panel, Bottom (NG)	P01003064L	1
56	Cart Panel, Right	P07606038G	1
57	Cart Panel, Left	P07605035G	1
58	Bowl Bracket	P03315026F	2
59	Caster Seat, Left Front & Right Rear	P05327064H	2
60	Caster Seat, Right Front & Left Rear	P05327065H	2
61	Caster, 3" without Brake	P05112026A	2
62	Caster, 3" with Brake	P05112027A	2
63	Cart Bracket, Front	P03305072F	1
64	Cart Panel, Top	P01003053D	1
65	Door Hinge Bracket, Left/Upper	P03313031F	1
66	Door Hinge Bracket, Right/Upper	P03313032F	1
67	Door Hinge Bracket, Left/Lower	P03313033F	1
68	Door Hinge Bracket, Right/Lower	P03313034F	1
69	Door Assembly, Left	P04305061G	1
70	Door Assembly, Right	P04306031G	1
71	Door Hinge	Y0550002	2
72	Door Magnet	P05523056L	4
73	Door Guide Plate	P05510137A	1
74	Cart Panel, Rear	P07702128D	1
75	Control Box Bracket	P03343018D	1
76	Electric Wire Protector	P055330043	1
77	Control Box	P05545006M	1
78	LED Light Controller	P05357022B	1
79	Electric Ignitor, 4-Port	P02502384C	1
80	Side Shelf, Left	P01102057F	1
81	Side Shelf, Right	P01103047F	1
82	Side Shelf Trim Plate, Left	P07503023A	1
83	Side Shelf Trim Plate, Right	P07502031A	1
84	Side Shelf Bracket	P03342015L	4
85	Spice Shelf	P05203012F	1
86	Tank Pull-out Tray Assembly	Y0530018	1
87	Tank Pull- out Tray Bracket	P03327110F	2
88	Bolt for Tank Pull- out Tray	P055101424	1
89	Electric Wire Set	P02627014A	1
90	Connection Hose - Long	P03702037D	2
91	Connection Hose - Short	P03702038D	2
92	Regulator with Hose Assembly (LPG)	P03603049A	1
93	LP Regulator Hose Holder	P055360034	1
94	Regulator (NG)	P03614005C	1
95	Lighting Stick	P05507140M	1
96	Hose, 12 FT. (NG) 3/8"ID (Optional)	P03703001A	1
	Hardware Pack (LPG)	P06006083A	1
	Hardware Pack (NG)	P06006084A	1
	Operator's Manual	P80151127A	1

# Assembly Instructions

**CAUTION:** While it is possible for one person to assemble this grill, obtain assistance from another person when handling some of the larger, heavier pieces.

## 1 Install Caster Seats

- Install the Caster Seats (LF/LR) on to the Left Cart Side Panel using 2 Pan Head Screws 1/4"x3/8" (A) and 4 Pan Head Screws 3/16"x3/8" (B) and tighten securely as shown.
- Repeat for Right Cart Side Panel and Caster Seats (RF/RR).

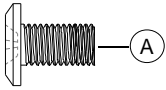

Pan Head Screw 1/4"x3/8"  
Qty. 4  
Part # S182G04061

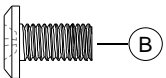

Pan Head Screw 3/16"x3/8"  
Qty. 8  
Part # S182G03061

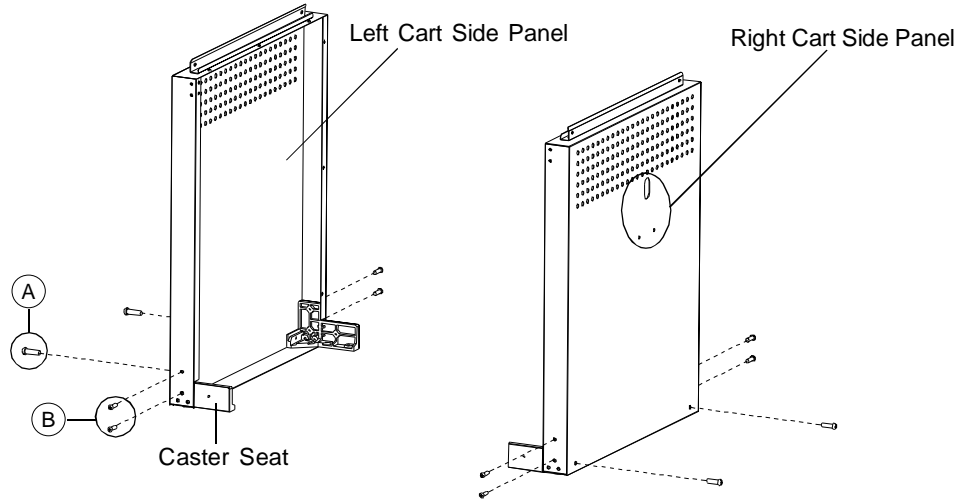

## 2 Install Cart Side Panels, Lower Door Hinge Brackets and Door Guide Plate

- Slide Cart Side Panels with attached Caster Seats onto the Cart Bottom Panel, making sure that the holes in the panels are aligned. Install 4 Pan Head Screws 3/16"x3/8" (A). Do not fully tighten the screws until the Door Hinge Brackets (Left/Lower and Right/Lower) and the Cart Rear Panel are attached (refer to Step 3).
- Install the Door Hinge Brackets Left/Lower and Right/Lower onto Cart Side Panels using 4 Pan Head Screws 3/16"x3/8" (A) and tighten securely.
- Secure the Caster Seats from the underside of the Cart Bottom Panel using 8 Pan Head Screws 1/4"x3/8" (B).
- Install the Door Guide Plate to the Cart Bottom Panel using 2 Pan Head Screws 3/16"x3/8" (A) and tighten.

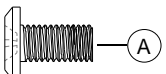

Pan Head Screw 3/16"x3/8"  
Qty. 10  
Part # S182G03061

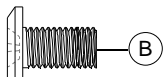

Pan Head Screw 1/4"x3/8"  
Qty. 8  
Part # S182G04061

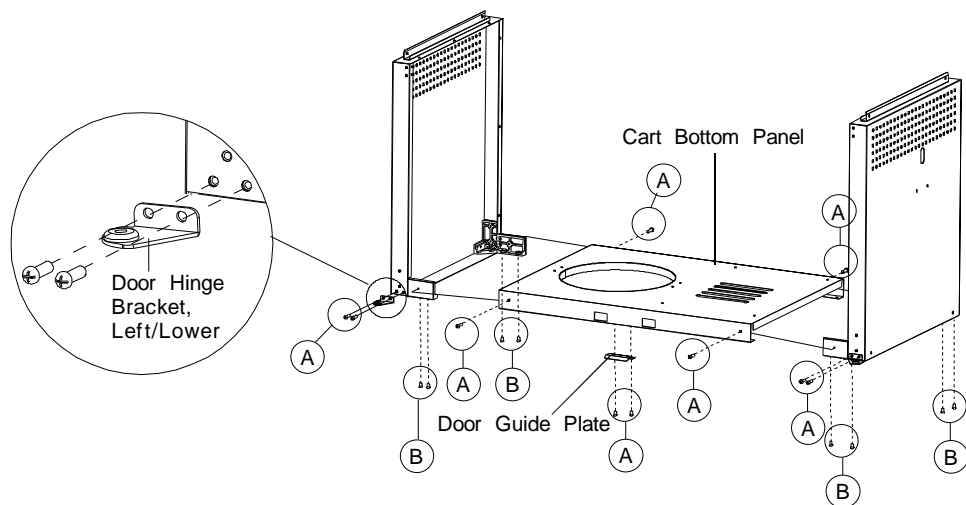

### 3

#### Install Hose Holder, Wire Clip, Casters and Cart Rear Panel

- Install the Hose Holder onto the Cart Rear Panel using 1 Pan Head Screw 3/16"x3/8" tighten securely.(see Fig.1)
- Install the Cart Rear Panel between the Cart Side Panels using 5 Pan Head Screws 3/16"x3/8" and tighten securely. (See Fig. 2)
- Install the Wire Clip with connection wire onto the left top hole of the Cart Rear Panel, insert 1 Pan Head Screw 3/16"x3/8" and tighten securely. ( see Fig.3)
- Secure the 4 Pan Head Screws installed on the Cart Bottom Panel and Caster Seats from step 2.
- Install 4 Casters onto the Caster Seats using the Wrench provided.

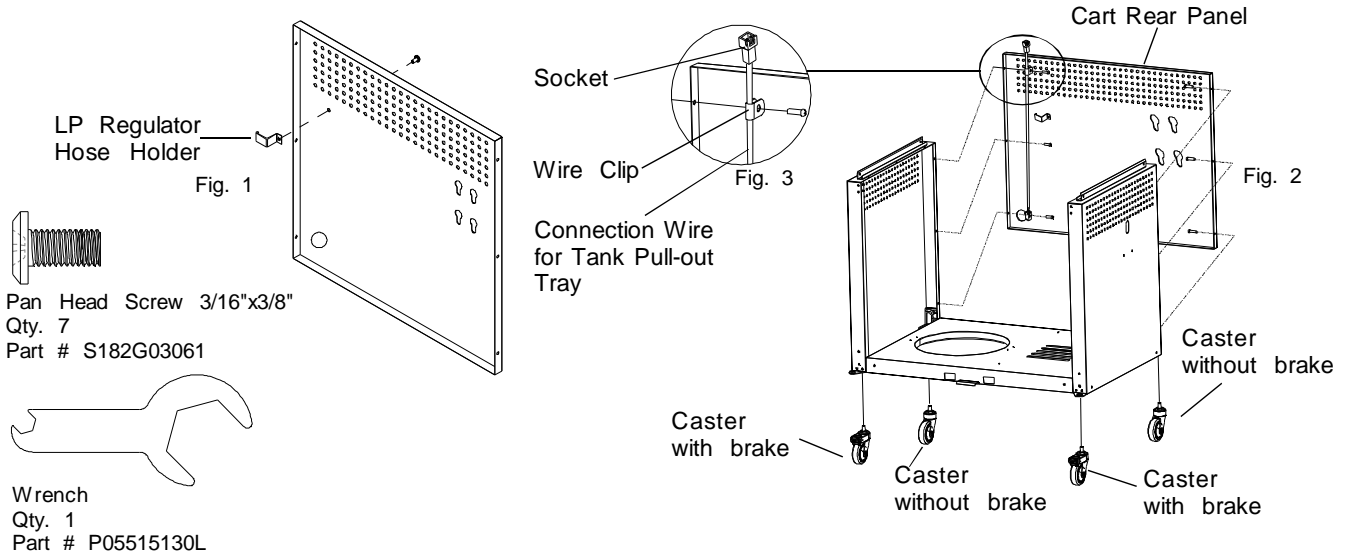

### 4-1

#### Install Tank Pull-out Tray Assembly onto Cart Bottom Panel (For OD2611BLP & OD3211BLP)

- Slide the right Tank Pull-out Tray Bracket into the right Slide.(Note: the left Tank Pull-out tray bracket has been installed by factory.)
- Place the Tank Pull-out Tray assembly onto the Cart Bottom Panel.
- Align the 4 holes on Tank Pull-out Tray Brackets with the 4 holes on the Cart Bottom Panel. Insert 4 Pan Head Screws 1/4"x3/8" and tighten securely.

### 4-2

#### Install Cart Top Panel

- Place Cart Top Panel on top of the assembled Cart. Position the Panel so that the hose hole is positioned to the Left Rear of Cart.
- Align the 5 holes in the Cart Top Panel with the 5 holes on the Cart Side Panels Left and Right. Insert the 5 Pan Head Screws 3/16"x3/8" and tighten.(refer to diagram)

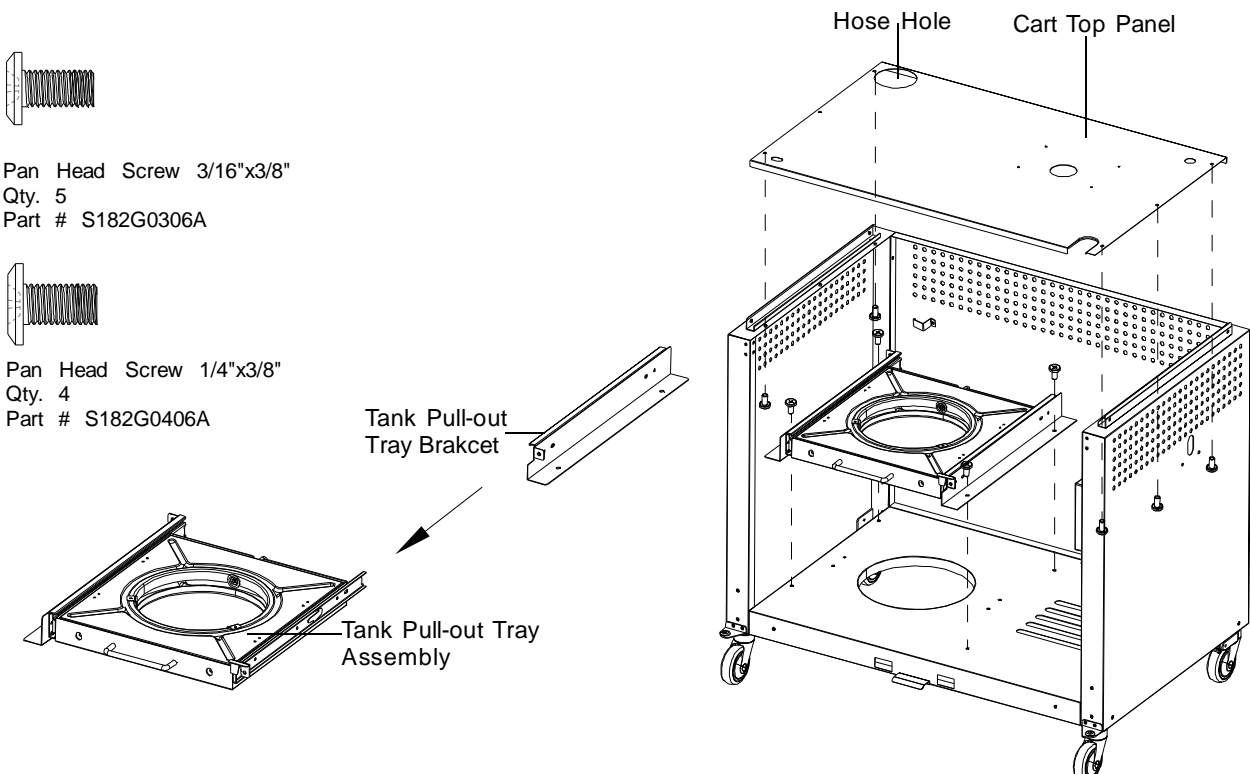

### 4-3 Install Spice Shelf (For OD3211BLP/NG) and Grease Receptacle

- Install the Spice Shelf onto the Cart Bottom Panel using 4 Pan Head Screws 3/16"x1/2" and tighten securely.
- Install the Grease Receptacle by placing it in the brackets under the Cart Top Panel.



Pan Head Screw 3/16"x1/2"  
Qty. 4  
Part # S182G03081

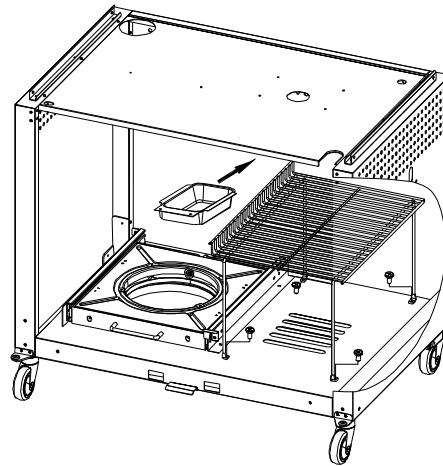

### 5-1 Install Grill Bowl, Control Box, Cart Bracket, Front and Batteries

- Make sure that the cooking components are removed from the Grill Head. With an assistant, lift and position the Grill Head onto the assembled Cart. Secure the Grill Bowl by installing 4 Pan Head Screws 3/16"x1". **Note:** Make sure that the Control Box wire protector goes through the "U" shaped hole in the Cart Panel, Top. For LP model, make sure the LP Regulator goes through the hose hole and put the LP regulator hose inside the Hose Holder, make sure the electric wires goes through the holes on the Cart Panel, Top.
- Install Control Box:** Align the holes in the Control Box bracket with the holes in the Cart Panel, Right using 2 Pan Head Screws 3/16"x3/8" and tighten securely.
- Install Cart Bracket, Front:** Attach 2 Pan Head Screws 3/16"x3/8" each in the Cart Panels Left and Right underneath the Control Panel. Tighten the screws only halfway. Place the Cart Bracket, Front onto the screws and fully tighten all the screws.
- Install Batteries:** Place 1 AA into the slot of the control panel and 4 AAA batteries into the slot of the Control Box as shown below.  
**Note:** The positive pole of the AA battery must face towards the cap. For the AAA batteries, 2 batteries must have the positive pole facing towards the cap and 2 batteries must have the negative poles facing away from the caps.) Position the caps onto the slots, and tighten them onto the Control Box.

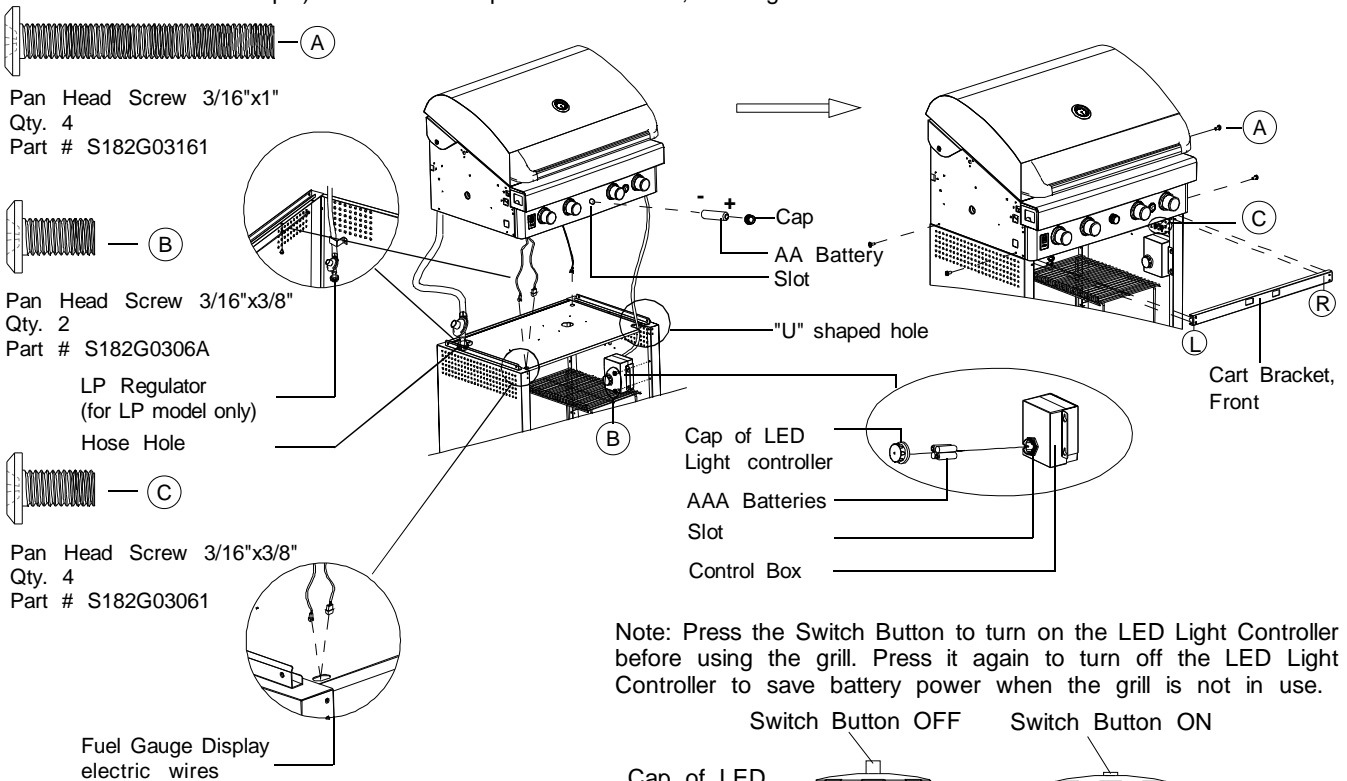

## 5-2

### Install NG Regulator and 12 Foot Hose (For OD2611BNG & OD3211BNG)

- Connect the NG Regulator to the Gas Manifold.
- Connect the 12 Foot Hose (not included in this unit) to the NG Regulator.

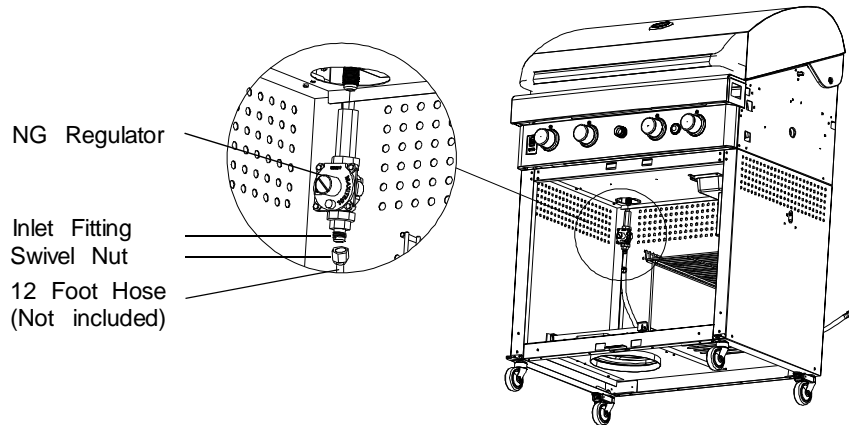

## 6

### Install Doors and Upper Door Hinge Brackets

- Install 2 Upper Door Hinge Brackets onto the Cart Panel Front using 8 Pan Head Screws 3/16"x3/8". (Note: The Upper Door Hinge Bracket for the left side is marked with an "L". The Upper Door Hinge Bracket for the right side is marked with an "R".)
- Locate the upper opening of the Door Assembly Left into the Door Hinge Bracket Left/Upper. Push up on the spring lever mechanism on the left Door Hinge located on the bottom of the door. Position the Door Assembly into the Door Hinge Bracket Left/Lower. Release the spring lever to lock the Door into the position.
- Repeat for the Door Assembly Right.

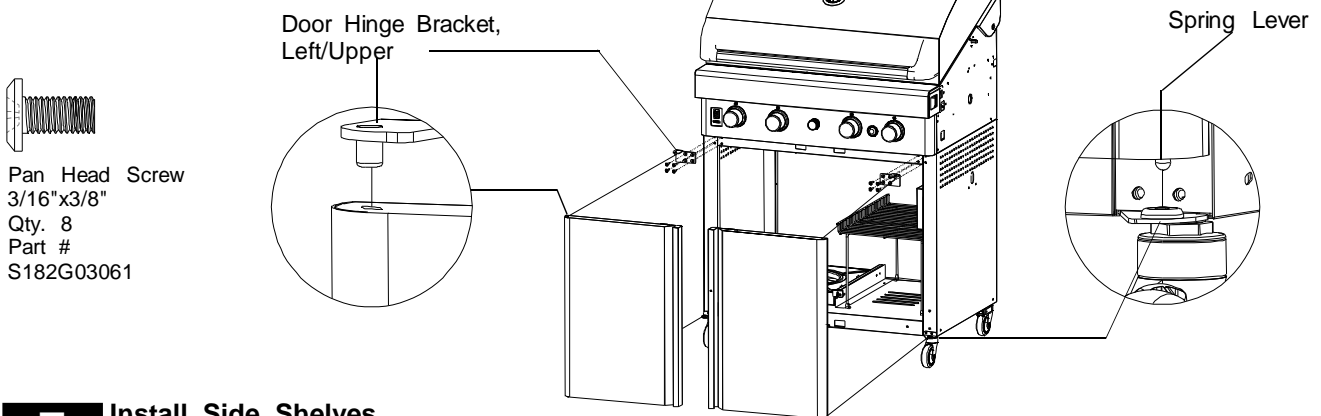

## 7

### Install Side Shelves

- Place the Side Shelf Brackets onto the Left Side Shelf (see diagram). Install the Brackets using 4 Pan Head Screws 3/16"x1" (A) and tighten securely.
- Insert the fittings of the Left Side Shelf Brackets into the holes on the Left Bowl Panel. Align the 5 holes on the Left Side Shelf with the 5 holes on the Left Bowl Panel. Insert the 4 Pan Head Screws 3/16"x3/8" (B) and 1 Pan Head Screw 3/16"x1/2" (C) and tighten securely.
- Repeat for the Right Side Shelf.

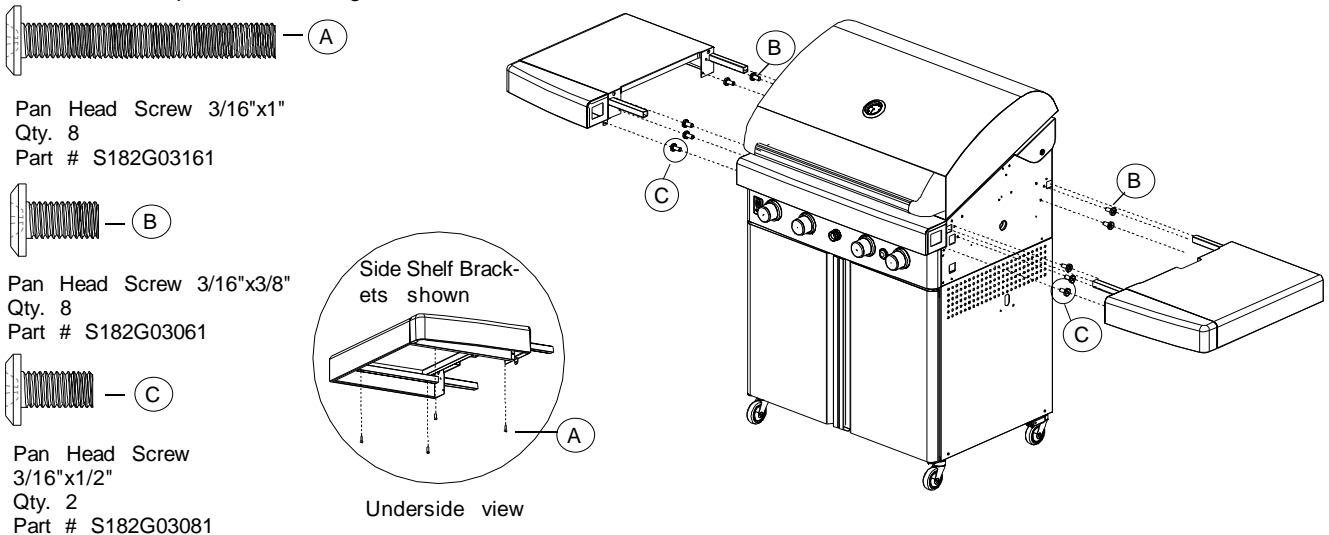

## 8

### Install Transformer

- Attach Transformer to the Cart Rear Panel by inserting four pre-assembled screws on the Transformer into the four holes on the Cart Rear Panel. Press the Transformer downward until the screws rest in place.
- Insert Transformer-Plug into Transformer-Socket and tighten securely. (see Fig. 1)
- Pull the Transformer Cord out through the hole on the Cart Rear Panel.
- Plug the Transformer Cord into a properly grounded 120VAC outlet.
- Push the Lamp Switch on the Control Panel to turn on the Grill lamps.

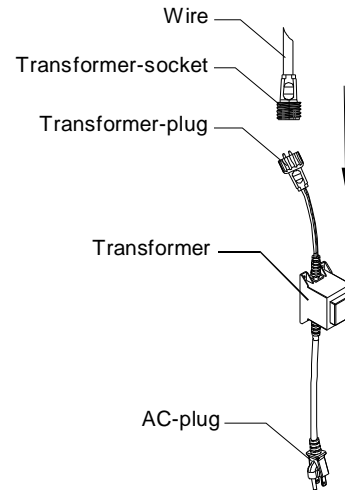
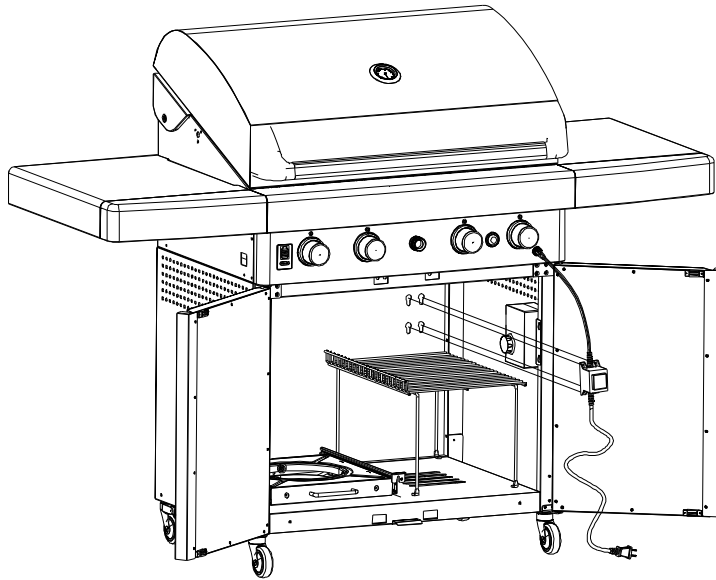

Fig. 1

## 9

### Install Battery Box and Connect electric wires(Only for OD2611BLP & OD3211BLP)

- Open the cap of the Battery Box and put 2 AAA batteries inside. Make sure the "+" and "-" ends are placed correctly as shown. Close the cap.(see Fig.1)
- Place the Battery Box Bracket over the holes of the Cart Left Panel, and then put the Battery Box into the Battery Box Bracket. (see Fig.2).
- Make sure threading two Electric Wires through the holes on the front Left of the Cart Top panel, push the plug of Fuel Gauge Display into the socket of Battery Box. Connect the plug of Fuel Gauge Display into the socket of Tank pull-out Tray.(see Fig.3)
- Attach the Wire Clip with Fuel Gauge Display wire to the hole of the Cart Top Panel, insert 1 Pan Head Screw 3/16"x3/8" from underside of the grill bowl and tighten securely.



Pan Head Screw 3/16"x3/8"  
Qty. 1  
Part # S182G0306A

Battery Box

AAA Battery

Battery Box Bracket

Plug

Socket

Fig.1

Fig.2

Fig.3

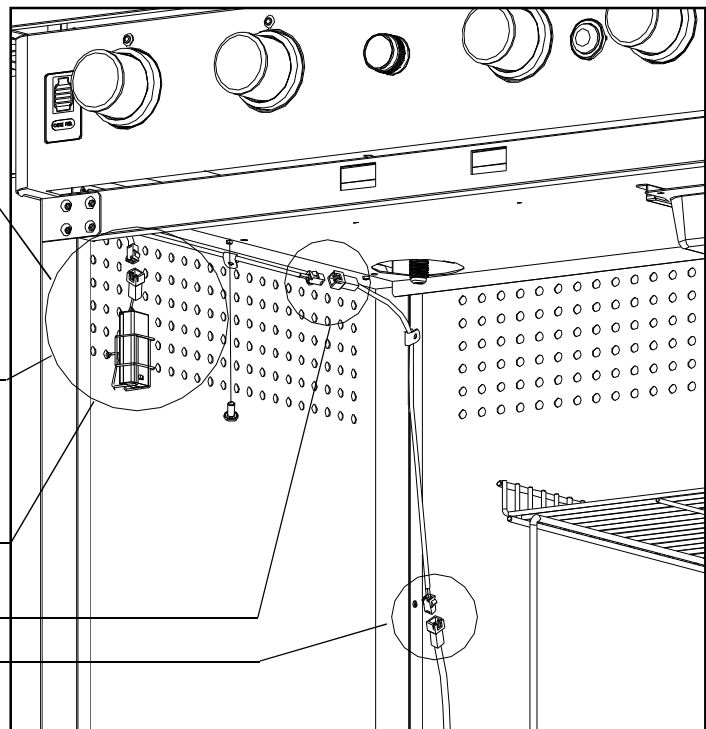

## 10 Install Grease Draining Tray

- Slide the Grease Draining Tray side tabs over the side rails underneath the Grill Bowl as shown.

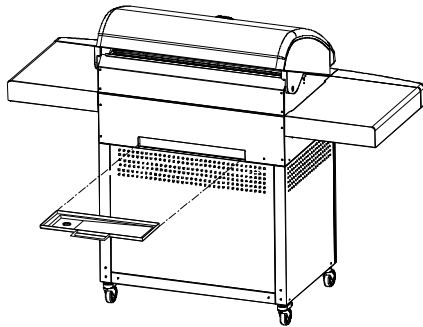

## 11 Main Burners Electrode Check Perform this Electrode Check with the assistance of another person

This test will ensure that the Spark Electrode Tips are properly positioned so your grill lights easily and properly.

- Ensure the gas source is turned off - or is disconnected and all Control Knobs are set to "OFF" and open the Grill Lid.
- Have your assistant stand to the right of the grill and look at both the front and rear burner locations of the grill bowl. **Never** put your face inside the Grill Bowl.
- Push and turn any Control Knob of Main Burners to ⚡ and push in. You should hear a "clicking" sound and have assistant watch for a blue spark within each Ignition Electrode.
- If no spark is seen, the Spark Gap needs to be adjusted as follows:
  - If the gap between the Spark Electrode Tip and Receiver is more than 1/8" wide, use needle nose pliers to gently squeeze the Spark Receiver to narrow gap. Try the Electrode Check again.
  - If no "clicking" sound is heard:
    - AA Battery may be installed backwards.
    - Electric wires may be loose. Remove the AA Battery and inspect the Ignitor Junction Box found in the Control Panel and reconnect any loose wires.

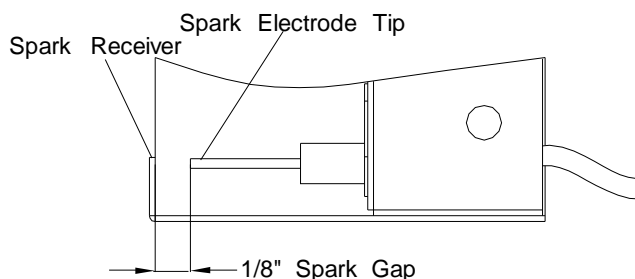

## 12 Install Grease Draining Tray Heat Shield and Cooking Components

- Install the Grease Draining Tray Heat Shield by matching the 4 holes on the Grease Draining Tray Heat Shield into the 4 pins in the Grill Bowl.
- Place Cooking Grids on bowl ledge.
- Place the Cooking Rack/Secondary into the slots on Grill Bowl Side Panels.

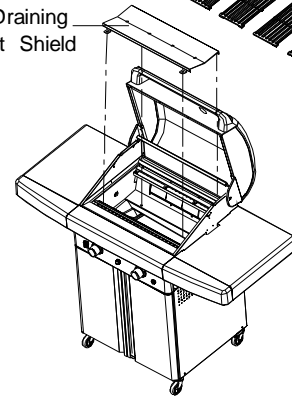
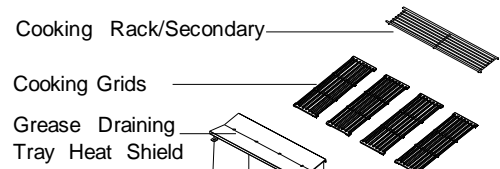

For OD2611BLP/NG Models

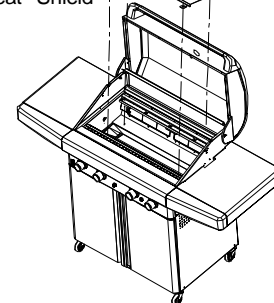
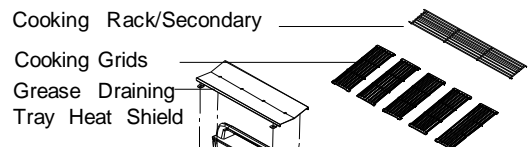

For OD3211BLP/NG Models

## Final Grill Assembly Step

When you have finished assembling your grill be sure that all screws are tightened for safe operation of your grill.

Before each use of the grill, make sure the Grease Tray and Receptacle are fully seated under the Grill Bowl.



**CAUTION:** The Grease Tray and Receptacle should be inspected before each grill use to be sure there is no excessive grease buildup. Clean the Grease Tray and Receptacle frequently to eliminate grease build-up and to prevent grease fires.

# LP Gas Tank Installation

## CORRECT LP GAS TANK USE

- LP Gas grill models are designed for use with a standard 20 lb. Liquid Propane Gas (LP Gas) tank, not included with grill. **Never** connect your gas grill to an LP Gas tank that exceeds this capacity. A tank of approximately 12 inches in diameter by 18-1/2 inches high is the maximum size LP Gas tank to use. **You must use an "OPD" gas tank which offers a listed Overfill Prevention Device.** This safety feature prevents the tank from being overfilled which can cause a malfunction of the LP Gas Tank, regulator, and/or grill.
- The LP Gas tank must be constructed and marked in accordance with the Specifications for LP-Gas Cylinders of the U.S. Department of Transportation (D.O.T.) or the National Standard of Canada, CAN/CSA-B339, Cylinders, Spheres and Tubes for Transportation of Dangerous Goods; and Commission, as applicable.
- The LP Gas tank must have a shutoff valve, terminating in an LP Gas supply tank valve outlet, that is compatible with a Type 1 tank connection device. The LP Gas tank must also have a safety relief device that has a direct connection with the vapor space of the tank.
- The tank supply system must be arranged for vapor withdrawal.
- The LP Gas tank must have a collar to protect the tank valve.
- Never** connect an unregulated LP gas tank to your gas grill. The gas regulator assembly supplied with your gas grill is adjusted to have an outlet pressure of 11" water column (W.C.) for connection to an LP gas tank. Only use the regulator and hose assembly supplied with your gas grill. **Replacement regulators and hose assemblies must be those specified by Grand Hall.**
- Have your LP Gas dealer check the release valve after every filling to ensure it remains free of defects.
- Always keep LP Gas tank in upright position.
- Do not subject the LP Gas tank to excessive heat.
- Never store an LP Gas tank indoors. If you store your gas grill in the garage **always** disconnect the LP Gas tank first and store it safely outside.
- LP Gas tanks must be stored outdoors in a well-ventilated area and out of the reach of children.
- Disconnected LP Gas tanks must not be stored in a building, garage or any other enclosed area.
- The regulator and hose assembly can be seen after opening the doors and must be inspected before each use of the grill. If your regulator and hose are damaged in any way, they must be replaced prior to using the grill again.
- Any attempt to convert the grill from one fuel type to another is extremely hazardous and will void the warranty.
- Never** light your gas grill with the lid closed or before checking to ensure the burners are fully seated over the gas valve orifices.
- Never** allow children to operate your grill. Do not allow children or pets to play near your grill. Always supervise children and pets if they are in the vicinity of the unit.



- Use of alcohol, prescription or non-prescription drugs can impair your ability to properly assemble and safely operate your grill.
- Keep fire extinguisher readily accessible. In the event of a oil/grease fire, do not attempt to extinguish with water. Use type B extinguisher or smother with dirt, sand or baking soda.
- In the event of rain, turn off the burners and gas supply. Wait for the grill to cool, and then place a cover on it.
- Use your grill on a level, stable surface in an area clear of combustible materials.
- Do not leave grill unattended when in use.
- Do not move the appliance when in use.
- Allow the grill to cool before moving or storing.
- Do not use your grill as a heater.
- This grill is not intended to be installed in or on recreational vehicles and/or boats.
- The grill is not intended for commercial use.
- Never use charcoal or lighter fluid in this gas grill.

WARNING

A. Do not store a spare LP-Gas tank under or near this appliance.

B. Never fill the tank beyond 80 percent full; and

C. If the information in "(a)" and "(b)" is not followed exactly, a fire causing death or serious injury may occur.

WARNING

- Use your grill at least 3 feet away from any wall or surface.
- Use your grill 3 feet away from any combustible objects that can melt or catch fire such as vinyl or wood siding, fences, overhangs (See Diagram Below), or any other sources of ignition; including pilot lights and live electrical appliances.
- Do not use your grill under any overhead combustible construction.
- Never use your gas grill in a garage, porch, shed, breezeway, or any other enclosed area.
- In windy conditions, always position the front of the grill to face oncoming wind to reduce heat and smoke blowing in your face, and to prevent potential hazards to yourself and the grill.

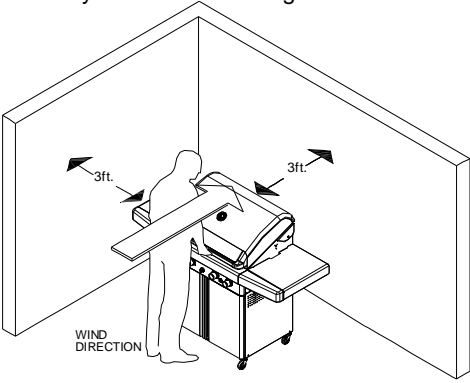

## USE AND CARE INSTRUCTIONS

### NOTE about LP Gas Tank Exchange Programs

- Many retailers that sell grills offer you the option of replacing your empty LP Gas tank through an exchange service. Use only those reputable exchange companies that inspect, precision fill, test, and certify their tanks. Exchange your tank only for an OPD safety feature-equipped tank as described in the LP Gas tank section of this Guide.
- Always keep new and exchanged LP Gas tanks in an upright position during use, transit or storage.
- Leak test new and exchanged LP Gas tanks BEFORE connecting one to your grill.

### How to Leak Test your LP Gas Tank

#### For your safety:

- All leak tests must be repeated each time your LP Gas tank is exchanged or refilled.
- When checking for gas leaks do not smoke.

Do not use an open flame to check for gas leaks.

- Your grill must be leak tested outdoors in a well-ventilated area, away from ignition sources such as gas fired or electrical appliances. During the leak test, keep your grill away from open flames or sparks.

- Do not use household cleaning agents. Damage to gas assembly components can result.

☞ Use a clean paintbrush and a 50/50 mild soap and water solution.

☞ Brush soapy solution onto LP Gas tank in the areas indicated by the arrows. See diagram.

☞ If growing bubbles appear do not use or move the LP Gas tank. Call an LP Gas Supplier or your Fire Department.

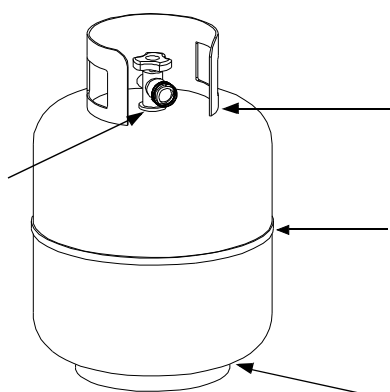

### To secure a 20lb LP Gas Tank to Gas Grill

- Turn your LP Gas Tank Valve clockwise to the closed or OFF position.
- Push the Bolt to the right, pull out the Tank pull-out Tray and place the Gas Tank in position, the Tank Valve should be facing the Rear left corner of Cart.
- Secure Gas Tank with the special Bolt on the back of the Tank Tray.

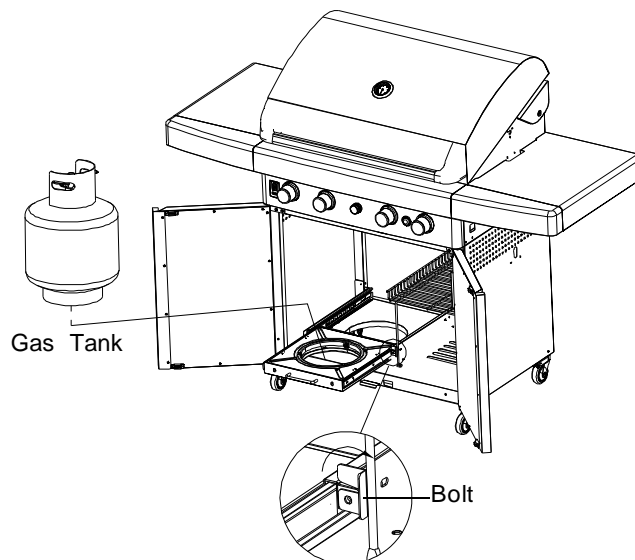

## WARNING



If growing bubbles appear do not use or move the LP Gas tank. Contact an LP Gas Supplier or your fire department!

# USE AND CARE INSTRUCTIONS

## LP Gas Model only:

### Connect Regulator with Hose to your LP Gas Tank

- Turn all Burner Valves to the OFF position.
- Inspect the valve connection port and regulator assembly for damage or debris. Remove any debris. Never use damaged equipment.
- Connect the regulator assembly to the tank valve and **HAND TIGHTEN** nut clockwise to a full stop. **DO NOT** use a wrench to tighten because it could damage the Quick Coupling Nut and result in a gas leak/fire hazard.
- Open the tank valve (counterclockwise) 1/4 to 1/2 of a full turn, and use a soapy water solution to check all connections for leaks before attempting to light your grill. See "**Check all connections for LP Gas Leaks**". If a leak is found, turn the tank valve off and do not use your grill until the leak is repaired.

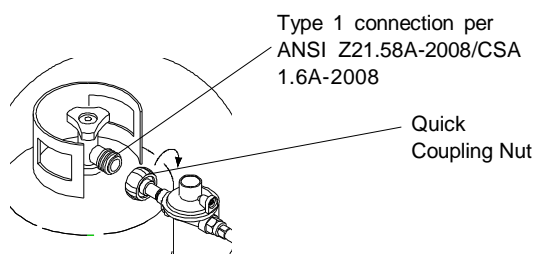

**CAUTION:** When the appliance is not in use the gas must be turned off at the tank. Place dust cap on cylinder valve outlet whenever the cylinder is not in use. Only install the type of dust cap on the cylinder valve outlet that is provided with the cylinder valve. Other types of caps or plugs may result in leakage of propane.



If you have a gas leak that cannot be repaired by tightening, turn off the gas at the source, disconnect fuel line from your grill and call 1-877-934-7455 or your gas supplier for repair assistance.



1. Do not store spare LP cylinder within 10 feet (3m) of this appliance.
2. Do not store or use gasoline or other flammable liquids and vapors within 25 feet (8m) of this appliance.
3. When cooking with oil/grease, do not allow the oil/grease to get hotter 350°F (177°C)
4. Do not leave oil/grease unattended.

### Check all connections for LP Gas Leaks

Never test for leaks with an open flame. Prior to first use, at the beginning of each season, or every time your LP Gas tank is changed, you must check for gas leaks. Follow these three steps:

- Make a soap solution by mixing one part liquid detergent and one part water.
- Turn the grill Control Knobs to the full OFF position, then turn the gas ON at source.
- Apply the soap solution to all gas connections indicated by the arrows. See diagram. If bubbles appear in the soap solution the connections are not properly sealed. Check each fitting and tighten or repair as necessary.

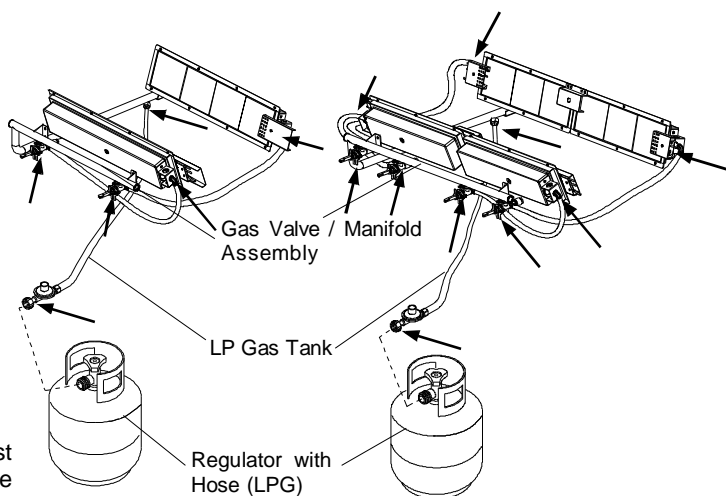

### Disconnecting A Liquid Propane Gas (LPG) Tank From Your Grill

- Make sure the Burner Valves and LP Gas tank valve are off. (Turn clockwise to close.)
- Detach the hose and regulator assembly from the LP Gas tank valve by turning the Quick Coupling Nut counterclockwise. Do not use a wrench or any tools when turning the Quick Coupling Nut.



Failure to read and follow the Use and Care Instructions could result in a fire or explosion that could cause serious bodily injury, death or property damage.

# Natural Gas Connection

## Natural Gas Model only: Connecting Natural Gas To Your Grill

- Connect the Swivel nut of the 12' Natural Gas Hose to the vertical fitting of NG Regulator as shown in **Fig.1**. Connect the other hose end (male plug) to the gas supply line from your home. Read and follow the "Natural Gas Safety Instructions" below.

## Natural Gas Safety Instructions

- Your natural gas grill is designed for use with natural gas (NG) only. The gas pressure Regulator supplied with this appliance **must** be installed and used on your grill. The unit and Regulator are set to operate with an outlet pressure of 4" W.C.
- Install a Shutoff Valve at the gas supply source outdoors at a point after the gas pipe exits the outside wall and before the quick-disconnect hose. Or install it at the point before the gas line piping enters the ground. See **Fig. 2**.
- Pipe sealing compound or pipe thread tape resistant to the action of natural gas must be used on all male pipe thread connections.
- Disconnect your gas grill from fuel source when the gas supply is being tested at high pressures. This gas grill and its individual shutoff valve must be disconnected from the gas supply pipe system during any pressure testing of that system at pressure in excess of 1/2 psi (3.5kpa).
- Turn off your gas grill when the gas supply is being tested at low pressures. The grill must be isolated from the gas supply pipe system by closing its individual manual shutoff valve during any pressure testing of the gas supply pipe system at pressures equal to or less than 1/2 psi (3.5kpa).

**Fig.2**

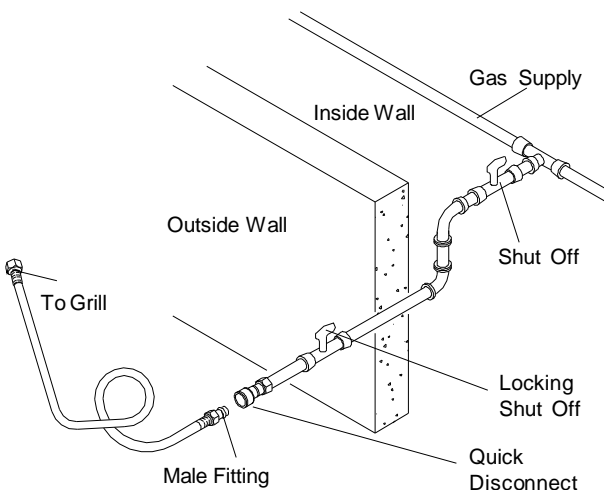

**Fig.1**

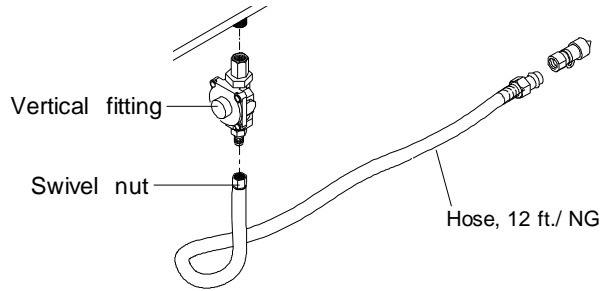

## Check all connections for Natural Gas Leaks

**Never** test for leaks with an open flame. Prior to first use and at the beginning of each season, you must check for gas leaks. Follow these three steps:

- Make a soap solution by mixing one part liquid detergent and one part water.
- Turn the grill Control Knobs to their full OFF positions. Next, turn the gas ON at the source.
- Apply the soap solution to all gas connections indicated by the arrows. See **Fig.3**. If bubbles appear in the soap solution the connections are not properly sealed. Check each fitting and tighten or repair as necessary.

**Fig.3**

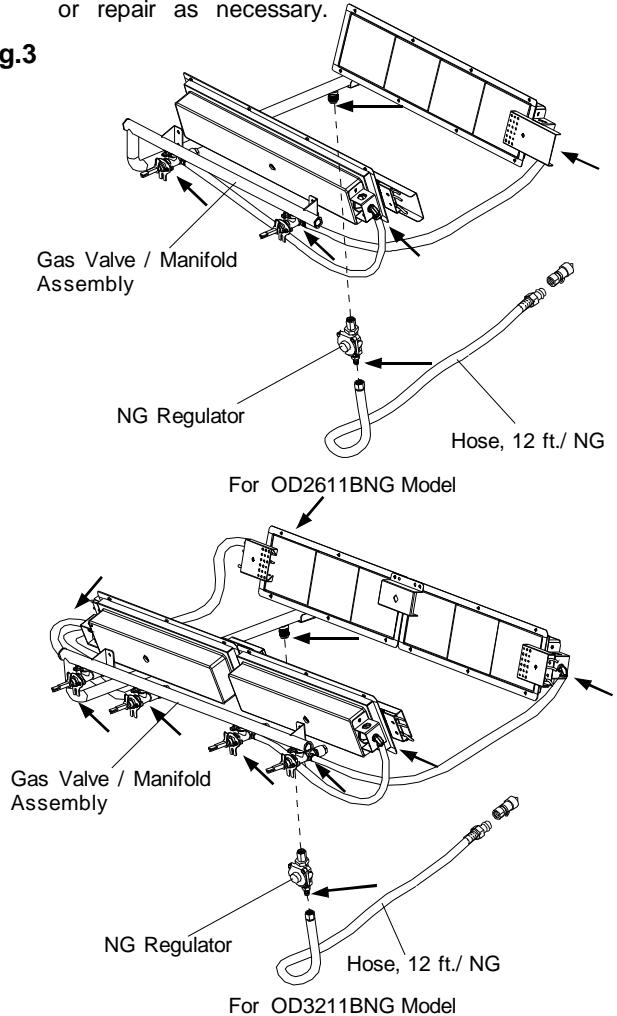

# USE AND CARE INSTRUCTIONS

## Grill Lighting Instructions

1. Before each use, check all hoses for cracks, nicks, cuts, burns, or abrasions. If a hose is damaged in any way, do not use your grill before replacing the hose with an authorized part from the Parts List. Also make sure all gas supply connections are securely tightened.
2. Familiarize yourself with the safety and Use and Care instructions in this Guide. Do not smoke while lighting grill or checking gas supply connections.
3. Be sure the LP Gas tank is filled, and lock Casters to prevent movement during grill operation.
4. Open the Grill Lid.

**WARNING**

Failure to replace a faulty hose, secure gas supply connections or to open the Lid before proceeding to the Lighting Procedures could result in a fire or explosion that could cause serious bodily injury, death, or property damage.

5. Set Control Knobs to OFF and open the LP Gas tank valve **SLOWLY 1/4 of a full turn**. For Natural Gas open the Shut Off Valve at the source.

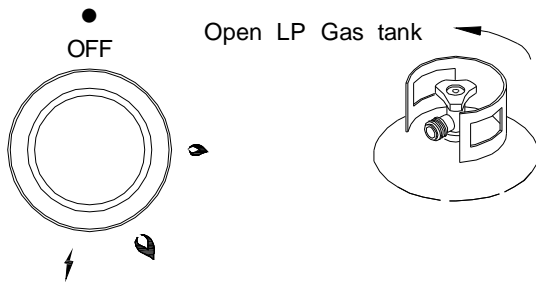

**Note:** You must press the Switch Bottom of the LED light controller on control box before lighting (refer to page 14).

6. Push and turn the control knob to ⚡ and hold it in 3-5 seconds to ignite the Burner. Once the burner is ignited continue to depress the knob and rotate to 🔥. Hold the knob until burner indicator light turns on then release it.

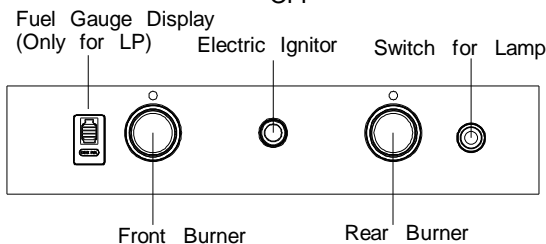
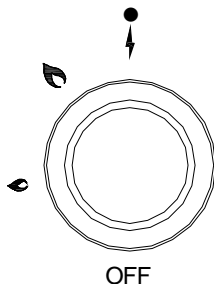

For OD2611BLP/NG Models

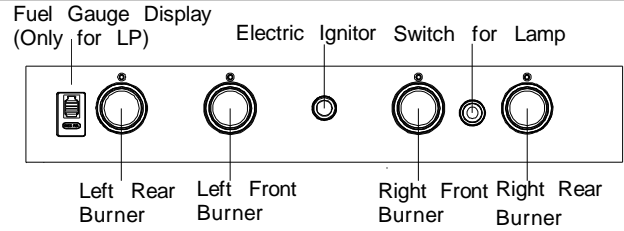

For OD3211BLP/NG Models

7. If ignition does not occur in 5 seconds, turn gas off at source and turn Control Knobs OFF. Wait at least 5 minutes for gas to clear, then retry. If your grill still fails to light turn the burner Control Knob(s) and gas source OFF and conduct a leak test of ALL gas connections and gas sources as explained in the Use and Care section of this guide. If no leaks are detected, wait 5 minutes for any gas to clear and repeat the lighting procedure.
8. If the burner indicator light does not work, check the battery.
9. After one Burner is lit, turn the tank valve **SLOWLY** one more 1/4 of a turn. If other burners need to be lit, turn each other burner knob to ⚡ to light, then back to 🔥.

## Manually Lighting Your Grill By Paper Match

To light your gas grill by match, insert a match into the Lighting Stick and follow steps 1 through 5 of the Grill Lighting Instructions. Then, light the match and place Lighting Stick through the Cooking Grid on the grill as shown below. Turn the correlated Control Knob to the 🔥 setting to release gas. The Burner should light immediately.

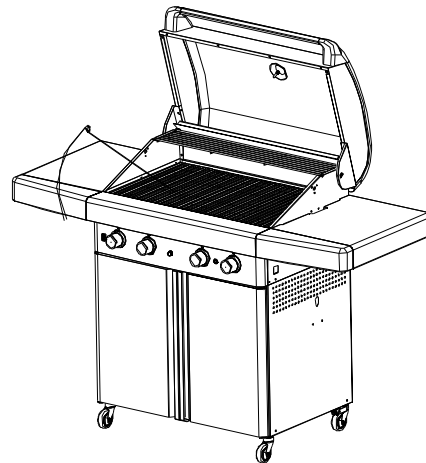

**Note:** Place the Lighting Stick on the inside of the Left Door when it is not in use.

**NOTE**

Replace the batteries when low battery as noted below:

1. If LED burner indicator light does not work when burner is lit.
2. If any of the LED indicator(s) is lit when its related burner is in "OFF" position.

# USE AND CARE INSTRUCTIONS

## Fuel Level Gauge Operation

Before using the Fuel Level Gauge be sure all electric wires are properly connected.

### 1. Initial setting for the Fuel Gauge Display:

**Note:** Do Not place the Gas Tank into the Tank pull-out Tray while conducting initial setting up for the Fuel Gauge Display .

Press "CHECK FUEL" button and hold for 5 seconds, then release. The Fuel Level Indicators will switch from full rows to the middle row only. Wait 3 seconds, press "CHECK FUEL" and release . The Fuel Gauge Display will show Gas Tank Icon It is then ready for use.

### 2. FuelLevelDisplay:

**Note:** Gas Tank must be connected to Tank pull-out Tray for Fuel Level check.

Press the "CHECK FUEL" button to check the gas volume. When the gas volume is low and the display shows only the last row, the indicator will flash to warn you that the gas tank is nearly empty.

### 3. Low Battery:

If the battery is low, the Fuel Level Display will light up once, then turn off automatically when you press "Check Fuel" button. If so, please replace the batteries.

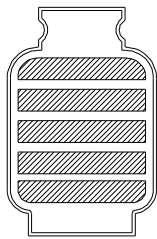
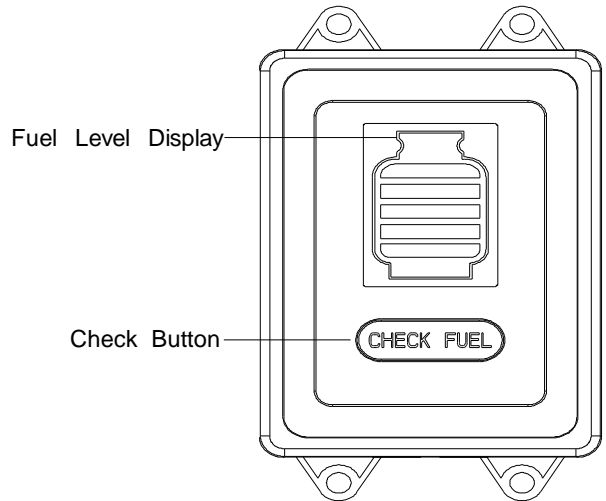

Full row

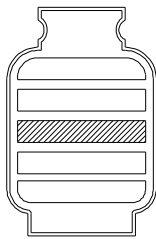

Middle row

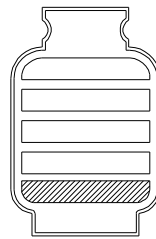

Last row

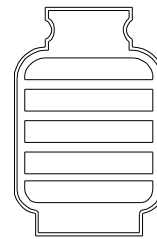



Gas Tank Icon

## USE AND CARE INSTRUCTIONS

### Troubleshooting

#### If the grill fails to light :



1. Turn gas off at source and turn Control Knobs to OFF. Wait at least 5 minutes for gas to clear, then retry.
  2. If your grill still fails to light, check gas supply and connections.
  3. Repeat lighting procedure. If your grill still fails to operate, turn the gas off at source, turn the Control Knobs to OFF, then check for the following issues:
- Obstruction in gas line  
**Correction:** Remove regulator hose from grill. Do not smoke! Open gas supply for one second to clear any obstruction from fuel line. Close off gas supply at source and reconnect fuel line to grill.
  - Disconnected Electric Wires  
**Correction:** Inspect the Electric Ignitor (see Parts List) found in the Control Panel. Connect loose Electric wires to Junction Box and try to light the grill.
  - Weak AA or AAA Battery  
**Correction:** Remove the Ignitor Cap and replace the battery.
  - If the grill still does not light you may need to purge air from the gas line or reset the regulator excess gas flow device. **Note:** This procedure should be done every time a new LP Gas tank is connected to your grill.

 **WARNING** 

**Never** lean over the grill cooking area while lighting your gas grill. Keep your face and body a safe distance (at least 18 inches) from the front of grill when lighting your grill by match.

#### To purge air from your gas line and/or reset the regulator excess gas flow device:

- Turn Control Knobs to the OFF position.
- Turn off the gas at the source.
- Disconnect regulator from LP Gas tank. For Natural Gas, disconnect regulator from 12 ft. Natural Gas Hose.
- Let unit stand 5 minutes to allow air to purge from gas line.
- Reconnect regulator to the LP Gas tank. For Natural Gas reconnect regulator to 12 ft. Natural Gas Hose.
- Turn tank valve on SLOWLY 1/4 of a full turn. For Natural Gas, open Shut Off valve.
- Open the Grill Lid.
- Push and turn the Control Knob to ⚡ and hold it in 3-5 seconds to ignite the burner.

 **WARNING** 

Should a FLASHBACK fire occur in or around the Burners, follow the instructions below. Failure to comply with these instructions could result in a fire or explosion that could cause serious bodily injury, death, or property damage.

- ÿ Shut off gas supply to the gas grill.
- ÿ Turn the Control Knobs to OFF position.
- ÿ Open the Grill Lid.
- ÿ Put out any flame with a Class B fire extinguisher.

# USE AND CARE INSTRUCTIONS

## CORRECT TRANSFORMER AND LIGHT USE

Read all instructions before initial use.

**IMPORTANT:** When using transformer appliances, basic safety precautions should always be used.

The Transformer is set for 120V, 60Hz AC current input, 12VAC, 25W output. The Light is set for 12V, 10W.

Do not let children operate or play nearby your grill or Transformer. Always supervise children and pets if they are in the vicinity of the unit.

### Connecting Transformer

Always attach the assembled Transformer to your grill first and then plug the Cord into a properly grounded outlet, then turn on the Lights.

### Operating Transformer and Light

Do not operate the Transformer if the cord or plug becomes damaged, or if the Transformer or Light malfunctions or have been damaged in any manner.

Do not immerse Electrical Cord or Plug in water or expose to rain, as this may result in an electrical shock.

### Disconnect Transformer

Be careful as all surfaces will be hot; including the grill, Transformer, and the Light. Turn off the Lights and unplug the Transformer from the electrical outlet when not in use and before cleaning.

## ELECTRICAL EQUIPMENT USE

1. To protect against electric shock, do not immerse cord or plugs in water or other liquid.
2. Allow Grill to cool before putting on or taking off parts.
3. Do not operate any outdoor cooking gas appliance with a damaged cord, plug, or after the appliance malfunctions or has been damaged in any manner. Call 1-877-934-7455 for repair.
4. Do not let the cord hang over the edge of a table or touch hot surfaces.
5. Do not use an outdoor cooking gas appliance for any purposes other than its intended use.
6. When connecting, first connect plug to the outdoor cooking gas appliance then plug appliance into the outlet.
7. Use only a Ground Fault Interrupter (GFI) protected circuit with this outdoor cooking gas appliance.
8. Never remove the grounding plug or use with an adapter of 2 prongs.
9. Use only extension cords with a 3 prong grounding plug, rated for the power of the equipment, and approved for outdoor use with a W-A marking.



To protect against electrical shock, do not immerse electrical cord or plugs in water or expose to rain. Protect electrical elements from burners, hot grill surfaces and grease.



**California Proposition 65**  
The electrical supply cord and plug of the Transformer contain chemicals, including lead, known to the State of California to cause cancer, and birth defects or other reproductive harm. Wash hands after handling.



This appliance, when installed, must be electrically grounded in accordance with local codes or, in the absence of local codes, with the *National Electrical Code*, *ANSI/NFPA 70*, or the *Canadian Electrical Code*, *CSA C22.1*.  
Keep any electrical supply cord and the fuel supply hose away from any heated surface.



To protect against shock hazard risk, connect only to properly Grounded Outlet.

## CLEANING AND MAINTENANCE

Proper care and maintenance will keep your grill in top operating condition and prolong its life. Follow these cleaning procedures on a timely basis and your grill will stay clean and operate with minimum effort.

**CAUTION:** Be sure your grill is OFF and cool before cleaning.

### Cleaning The Cooking Grids

- Before initial use and periodically thereafter, wash your Cooking Grids in a mild soap and warm water solution. You can use a wash cloth or vegetable brush to clean your Cooking Grids.

### Cleaning The Grease Draining Tray and Receptacle

- To reduce the chance of fire, the Grease Draining Tray and Receptacle should be visually inspected before each grill use. Remove any grease and wash the Grease Draining Tray and Receptacle with a mild soap and warm water solution.

### Cleaning the Inside of the Grill Lid

- Grease can build up on the inside of the Grill lid over time. This grease can drip onto your deck or patio when the lid is opened. Visually inspect the inside of the Grill Lid before each grill use. Remove any grease and wash with a mild soap and warm water solution.

### Routine Cleaning of The Grill Interior

- Burning-off excess food after every cookout will keep it ready for instant use. However, at least every 3 months you must give the entire grill a thorough cleaning to minimize your risk of grease fire and keep the grill in top shape. Follow these steps:
  1. Turn all Burner Knobs to the full OFF position.
  2. Turn the gas off at the source.
  3. Disconnect the Regulator from the source. Inspect the hose with regulator assembly for cracking, cuts or any other damage, and replace as necessary. Refer to the Parts List in this Operator's Manual.
  4. Remove and clean the Cooking Grids and Secondary Cooking Rack.
  5. Brush the inside and bottom of the grill with a fiber pad or nylon brush and wash with a mild soap and warm water solution. Rinse thoroughly and let dry.
  6. Check each Spark Electrode, adjusting as needed. The space between the Spark Electrode Tip and Spark Receiver should be approximately 1/8" .
  7. Replace the Cooking Grids and Secondary Cooking Rack.
  8. Reconnect the gas source and observe the Burner flame for correct operation.

### Cleaning Exterior Painted Surfaces:

- Before initial use, and periodically thereafter, we suggest you wash your grill using a mild soap and warm water solution. You can use a wash cloth or sponge for this process. Do not use a stiff wire or brass brush. These will scratch stainless steel and chip painted surfaces during the cleaning process.

### Cleaning Exterior Stainless Steel Surfaces:

- Routine care and maintenance is required to preserve the appearance and corrosion resistance of stainless steel. The fact is stainless steel can corrode, rust and discolor under certain conditions. Rust is caused when regular steel particles in the atmosphere become attached to the stainless steel surface. Steel particles can also become attached to your grill if you use steel wool or stiff wire brushes to clean the grill instead of non-abrasive cloth, sponge or nylon cleaning tools. In coastal areas rust pits can develop on stainless surfaces that cannot be fully removed. Bleach and other chlorine based solutions used for household and pool cleaning can also cause corrosion to stainless steel. Weathering, extreme heat, smoke from cooking and machine oils used in the manufacturing process of stainless steel can cause stainless steel to turn tan in color. Although there are many factors which can affect the surface appearance of stainless steel, they do not affect the integrity of the steel or the performance of the grill.

- To help maintain the finish of stainless steel follow these cleaning tips for the best results:
  1. After every use (after your grill has cooled down), wipe stainless surfaces with a soft, soapy cloth or sponge then rinse with water. Be sure to remove all food particles, sauces or marinades from stainless steel because these can be highly acidic and damaging to stainless surfaces.
  2. Never use abrasive cleaners, scrubbers or stiff wire brushes of any type on your grill.
  3. Use a heat resistant Stainless Steel Cleaner and rub or wipe in the direction of the stainless steel grain or polish lines. Do not polish against the grain.



## WARNING



**Failure to comply with these instructions could result in a fire or explosion that could cause serious bodily injury, death or property damage.**

Keep grill area clear and free from combustible materials, gasoline and other flammable vapors and liquids.

Do not obstruct the flow of air for combustion and ventilation.

Keep the ventilation openings of the tank enclosure cabinet free and clear of debris.

Visually check burner flames occasionally to ensure proper flame pattern as shown below.

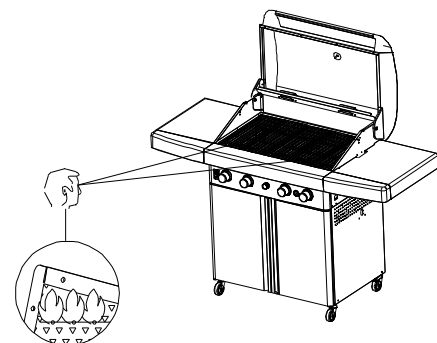

**MAGNIFIED VIEW OF INFRARED BURNER FLAME THROUGH OPEN LID.**



## WARNING



**Do not leave the grill unattended during burn off. Empty and clean the Grease Draining Tray and Grease Receptacle before doing burn-off.**

# Infrared Grill Cooking Instructions

## Burn-Off

- Before cooking on your gas grill for the first time, you should "burn off" the grill to eliminate any odor or foreign matter. Ignite the burners, lower the Lid, and operate grill on 🔥 setting for 3 to 5 minutes.

**CAUTION:** Infrared cooking times will be much shorter than traditional grilling so never operate this appliance unattended.

## Preheating

- To preheat, light your grill on 🔥, lower the Lid and follow this timetable.

☞ For searing and high temperature cooking, preheat grill 3 to 5 minutes.

☞ For low temperature cooking, preheat grill 3 minutes.

☞ To slow cook, preheating is not necessary.

## Control Knob Settings

- **High setting:** The 🔥 Control Knob setting should only be used to pre-heat your grill the first 3-5 minutes, for searing foods and for burning food residue off the grill for 3-5 minutes after cooking is complete.

**CAUTION:** Infrared cooking times will be much shorter than traditional grilling so never operate this appliance unattended.

- **Low setting 🔥:** Most recipes specify the low setting for baking, roasting, rotisserie cooking and grilling delicate foods such as fish, vegetables and bread.

## An Important Note About Infrared Heat Settings

- The suggested heat settings and cooking times shown in the following pages are approximate. Unlike the controlled environment inside your kitchen, variables including outside temperatures, direction and conditions of wind, as well as grill location will affect your grill's heat distribution. Because these conditions vary, and no two backyards are alike, we offer these tips as general guidelines for your reference. We recommend you monitor your grill closely and rotate foods often to prevent overcooking and ensure the most delicious results every time.

☞ The heat from the front and rear infrared burners overlap in the mid section of each cooking grid. This area offers the most intense heat for quickly locking in the natural juices and flavor of poultry and meats.

☞ The Secondary Cooking Rack offers less intense heat for preparing breads and firm vegetables like potatoes and corn.

☞ Infrared heat sears the food surface and cooks from the inside out. Infrared heat does not cook through aluminum foil and reflective pans. For roasting and baking you'll find a cast-iron pan works beautifully as it absorbs and conducts the infrared heat very well.

## Direct Cooking

- The direct cooking method can be used with the food placed on the mid section of each cooking grid where the infrared heat is most intense. **Direct Cooking requires the Grill Lid to be open.** This method is ideal for searing and grilling as well as deep frying in a cast-iron pan or stir-frying in a steel wok.

## Indirect Cooking



- To cook **indirectly**, the food should be placed on the left or right side of your grill (or Secondary Rack) with the Burners lit on the opposite side. Rotate the food as needed to ensure even browning. This is the slow cooking method. A faster indirect method is to place your food in an optional cast-iron cooking pan and place it in the center of the grill with all burners on LOW. Be sure to add liquid if using a pan to keep food moist. If higher heat is desired, turn Left Front (LF) and Right Rear (RR) burners on HIGH with Left Rear (LR) and Right Front (RF) burners on LOW to create a crossray cooking pattern. Either way, **indirect cooking must be done with the Lid down.**

## Prepare Cooking Grids for Grilling

- Greasing the cooking surface will help keep foods from sticking during the cookout, produces beautiful sear marks and reduces the amount of cleanup required. Use a brush to apply a thin layer of cooking oil or vegetable shortening onto each Cooking Grid before each cookout. We do not suggest spray type oils unless they are specified for high-temperature cooking.

## To Reduce Flare-Ups and Smoke

- Fat and juice dripping from grilled food can cause flare-ups and smoke. To minimize this:
  - ☞ Trim excess fat from meats and poultry
  - ☞ Preheat the grill properly
  - ☞ Clean the grill regularly to remove food and grease build-up
  - ☞ Reposition your food if needed

 **WARNING** 

**Failure to comply with these instructions could result in a fire or explosion that could cause serious bodily injury, death or property damage.**

- ☞ Never cover the cooking grids, bottom of the grill bowl, Grease Draining Tray or Grease Receptacle with charcoal, aluminum foil, sand, or any substance that can absorb grease.
- ☞ **Before each use of your grill:** Inspect the Grease Draining Tray and Receptacle to be sure there is no excessive grease buildup. Clean the Grease Draining Tray and Receptacle frequently to eliminate grease build-up and to prevent grease fires.
- ☞ **Use your grill at least 3 feet away from any wall or surface.** Use your grill at least **3 feet away** from combustible objects that can melt or catch fire (such as vinyl or wood siding, fences and overhangs) or sources of ignition including pilot lights on water heaters and live electrical appliances.
- ☞ **Never** use this gas appliance on a balcony, deck, or patio above the ground floor of your home.
- ☞ **Never** use your gas grill in a garage, porch, shed, breezeway or any other enclosed area.
- ☞ **Your grill will get very hot.** Always wear a flame retardant BBQ Mitt when cooking on your grill. Never lean over cooking areas while using the grill. Do not touch cooking surfaces, Lid, grill housing, or other parts while the grill is in use, or until the grill has cooled down after use.

# Guide to Infrared Grilling using the Direct Cooking Method

## Grilling Steak and Ribs

Turn the grill Burners on 🔥, close the Lid and preheat your grill 3 to 5 minutes. Open Lid and place food on the mid section of a Cooking Grid. Sear 2-3 minutes on each side then adjust the Infrared Burners to LOW and continue cooking until desired doneness. You can also move the seared meat to the Secondary Cooking Rack to finish cooking. This method allows you to sear and prepare larger amounts of meat and keep cooked food warm. Grilling times will vary according to meat thickness.

## Grilling Hamburgers, Brats and Sausages

Turn the grill Burners on 🔥, close Lid and preheat your grill 3 to 5 minutes. Open Lid and place food on the mid section of a Cooking Grid. Sear 2-3 minutes on each side then adjust the Infrared Burners to LOW and continue cooking until desired doneness. Grilling times will vary according to meat thickness.

## Grilling Poultry

Turn the grill Burners on 🔥, close Lid and preheat your grill 2 to 3 minutes. Open Lid and place food on the mid section of a Cooking Grid. Sear 2-3 minutes on each side then adjust the Infrared Burners to LOW and continue cooking until desired doneness.

To minimize flare-ups, use skinless poultry or use the indirect method. Place the poultry on one side of the grill with the opposing Burners on LOW heat, and lower the grill Lid.

## Grilling Pork

Turn the grill Burners on 🔥, close Lid and preheat your grill 3 to 5 minutes. Open Lid and place food on the mid section of a Cooking Grid. Sear 2-3 minutes on each side then adjust the Infrared Burners to LOW and continue cooking until desired doneness. Grilling times will vary according to meat thickness.

## Whole Fish and Whole Fillets

Turn the grill Burners on 🔥, close Lid and preheat your grill 3 to 5 minutes. Open Lid and place food (skin down) on the mid section of a Cooking Grid. Sear 2 minutes on each side then adjust the Infrared Burners to LOW and continue cooking until fish is opaque but still moist.

## Vegetables and Fruit

Prepare your fruit or vegetables and brush with butter or basting sauce if desired. In some instances, you may want to grill vegetables and fruit **directly** over the heat, using the supplied Cooking Grids. Foods that work best with direct heat are relatively soft and require a short cooking time: mushrooms, zucchini, tomatoes and skewered fruit such as apricots, peaches, pineapple, strawberries and kiwis. Remember the **Grill Lid must remain up when cooking directly**.

To cook **indirectly**, the food should be placed on the left or right side of your grill (or Secondary Rack) with the Burners lit on the opposite side. Either way, **indirect cooking must be done with the Lid down**.

## Cut of Meat

T-bone steak  
Sirloin steak  
Beef spare ribs  
Porterhouse Steak  
New York strip steak

## Approx. Total Cooking Times

**Rare:** 4-6 minutes  
**Medium:** 6-8 minutes  
**Well done:** 8-10 minutes

Hamburgers  
Brats  
Sausages

**Rare:** 3-4 minutes  
**Medium:** 5-6 minutes  
**Well done:** 6-8 minutes

Chicken breast  
(cook with bone down)  
Chicken wings  
Drumsticks

**Direct method:**  
approximately 6-8 minutes

**Indirect method:**  
up to 30 minutes

Whole bird  
(cook with breast up)

**Indirect method:**  
approximately 1 hour

Chops  
Loins  
Cutlets

**Medium:** 10-12 minutes  
**Well done:** 12-14 minutes

Whole fish  
Whole fish fillets

Approx. 8 - 18 minutes or  
until fish is opaque

For very firm vegetables—particularly potatoes and yams, we recommend that you partially boil until almost cooked, before placing them on the grill.

**CAUTION:** Infrared cooking times will be much shorter than traditional grilling so never operate this appliance unattended.

**NOTE:** Do not use aluminum foil to wrap vegetables and fruit. Infrared heat does not cook through aluminum foil and reflective pans.

# Guide to Roasting & Baking using the Indirect Cooking Method

## An Important Note About Infrared Heat Settings

The suggested heat settings and cooking times shown are approximate. Unlike the controlled environment inside your kitchen, variables including outside temperatures, direction and conditions of wind, as well as grill location will affect your grill's heat distribution. Because these conditions vary, and no two backyards are alike, we offer these tips as general guidelines for your reference. We recommend you monitor your grill closely and rotate foods often to prevent overcooking and ensure the most delicious results every time.

## Preparing to Roast

Roasting uses the **indirect cooking** method. Therefore, the food should be placed on the left or right side of your grill with the Burners lit on the opposite side. You can also use an optional cast-iron pan underneath food allowing you to collect juices for making gravies. Remember, indirect cooking requires the Lid of your grill to be down.

Preheating your grill is not required for slow cooking methods such as roasting. If you do choose to preheat your grill before roasting, turn the Burners on HIGH and close Lid for approximately 2 minutes.

## Food preparation

Trim meat of excess fat. Truss meat and poultry with cooking string to retain shape if desired. Bacon strips can be used to cover the outside surface of lean meat and poultry to help prevent it from drying out. If using an optional cast-iron pan for cooking, you should also add liquid to prevent burning the bottom of your food.

## Tips for roasting

Except when roasting with water in a roasting pan, the juices that collect in the pan can be used as the base for a tasty sauce or gravy. Place a cooking pan directly over the heat, add extra butter if needed, then add several spoonfuls of flour to thicken sauce. Finally, add sufficient chicken or beef stock to obtain the desired consistency.

Once the meat is cooked, remove it from your grill and cover with a piece of foil. Allow it to stand for 10-15 minutes which allows the juices to settle. This will make carving easier and ensure a tender, juicy roast.

Type of Food	How Cooked	Approximate Cooking Times
Beef	Rare	14 minutes per pound
	Medium	18 minutes per pound
	Well done	20 minutes per pound
Lamb	Medium	14 minutes per pound
	Well done	18 minutes per pound
Veal		22 minutes per pound
Pork		23-26 minutes per pound
Chicken		17-20 minutes per pound
Duck		20 minutes per pound
Fish		8 minutes per pound
Turkey, under 16 pounds		17-20 per pound + 20 minutes
Turkey, over 16 pounds		14-18 per pound + 10 minutes

## BAKING TECHNIQUES

### Preparing to Bake

To bake in your new grill you'll need a baking dish or cast-iron cooking pan, and a pair of flame retardant BBQ Mitts. If the cooking pan is cast-iron be sure to season the pan before use.

Preheat your grill 3 minutes, then lower heat as needed. Baking uses the **indirect cooking** method. To cook **indirectly**, the food should be placed on the left or right side of your grill with the Burners lit on the opposite side. This is the slow cooking method. A faster indirect method is to place your food in an optional cast-iron cooking pan and place it in the center of the grill with all burners on LOW. If higher heat is desired, turn Left Front (LF) and Right Rear (RR) burners on HIGH with Left

Rear (LR) and Right Front (RF) burners on LOW to create a crossray cooking pattern. Either way, **indirect cooking must be done with the Lid down.**

### Tips for Baking

Prepare your favorite recipe as you would in the kitchen. You will need to stir the food several times as it bakes, and add additional liquid as required. Watch the temperature, and adjust to cook according to your recipe directions.

### Oven Temperature

Slow	300° - 340° F
Moderate	355° - 390° F
High	410° - 480° F

### Recommended Grill Setting

Left or right 2 burners on LOW
All 4 burners on LOW
LF + RR burners on HIGH and LR + RF burners on LOW

## Infrared Rotisserie Cooking

### Balancing the Food

In rotisserie cooking, balancing the food is of utmost importance. The rotisserie must turn evenly or the stopping and starting action will cause the food to cook unevenly and possibly burn the heavier side.

The easiest foods to balance are those of uniform shape and texture. To test if the food is balanced correctly when secured, place the ends of the rotisserie spit loosely in the palms of your hands. If there is no tendency to roll, give the spit a quarter turn. If it is still stable, give it a final quarter turn. It should rest without turning in each of these positions. It can then be attached to your grill.

### Food Preparation

When preparing poultry, truss the birds tightly so that wings and drumsticks are close to the body of the bird. The cavity of the bird may be stuffed prior to this. Pull the neck skin down and, using a small skewer, fix it to the back of the bird. Push the rotisserie spit through lengthwise, catching the bird in the fork of the wishbone. Center the bird and tighten with the holding forks. Test the balance as described before.

A rolled piece of meat requires the rotisserie skewer to be inserted through the center of the length of meat, then secured and balanced. For meats that contain bones, it is best to secure the rotisserie skewer diagonally through the meaty sections.

### Slow Cooking with a Rotisserie

Your Crossray Infrared Cooking System® by Grand Hall is the ideal set-up for Rotisserie cooking because of the unique position and angle of the infrared burners. Rotisserie cooking produces foods that are moist, flavorful and attractive. The optional Rotisserie Kit is most commonly used for cooking meat or poultry and is designed to cook food slowly.

After your food is balanced on the Rotisserie Spit and attached to your grill, turn the Rotisserie motor on. Observe the rotation to be sure the Rotisserie is turning evenly, then turn the front and rear Burners on LOW. Infrared rotisserie cooking on LOW heat can be done with the Lid open or closed.

**CAUTION:** DO NOT rotisserie cook with all burners on high and the Lid closed. The intense infrared heat will overcook your food and can damage your grill. Never operate this appliance unattended.



## Guide to Smoking

### Preparing to Smoke

Smoking gives food a distinctive, delicious flavor. You will find a variety of wood chips available for use in smoking grilled foods. Pre-soaking of wood chips may be required so read and follow the manufacturer's instructions for preparing smoking chips prior to use.

**NOTE:** It is our experience that many smoking chip products do not actually produce a smoke but instead infuses the food with flavor. Please read product labels carefully and if in doubt, ask your retailer for details.

### Using A Cast-Iron Smoker Box

There are many optional smoker boxes available for purchase but cast-iron is the type recommended for use with your infrared grill. Follow these guidelines and always refer to the label of your smoking chips for specific directions.

Turn the front or rear grill burners on HIGH, close Lid and preheat your grill 3 to 5 minutes. Fill your smoker box with your prepared smoking chips. Wear a flame retardant BBQ Mitt and place your smoker box about 6 inches from the back of a Cooking Grid directly above a lit grill Burner. Allow smoker chips to heat about 30 minutes (or until the scent of smoke is evident) then turn Burners to LOW and add your food.

To cook **indirectly**, the food should be placed on the left or right side of your grill (or Secondary Rack) opposite the lit burners and smoker box. **When cooking with a smoker box the Lid must be down.**

### Tips for Smoking

You can reduce the strength of the smoke flavor by only smoking for half or three quarters of the cooking time.

Foods naturally high in oils lend themselves well to smoking, while drier foods benefit from a marinade.

- **Tuna steaks**, marinated in Asian flavors of sesame oil, soy sauce and sherry.
- **Pork fillets**, rubbed with ginger, orange rind and brushed with maple syrup.
- **Mussels**, brushed with lemon rind and chili oil.
- **Lamb cutlets**, marinated in virgin olive oil, lemon, oregano and black pepper. The same marinade can be used for a whole leg or rack of lamb.
- **Chicken**, boneless chicken pieces—especially sliced breasts.
- **Fish**, sliced fillets of firm fish, assorted seafood such as prawns, scallops and calamari.
- **Pork**, sliced fillets, diced or minced pork, sliced leg steak, sliced chops.
- **Beef**, sliced fillet, rib-eye, round, rump, sirloin.
- **Lamb**, sliced fillet, round, loin.

## Guide to Stir-Frying and Deep-Frying

### STIR-FRYING TECHNIQUES

This method of cooking is popular around the world and can be easily accomplished outdoors on your gas grill. It's a quick and healthy way of preparing a complete meal using meat, poultry or seafood in infinite combinations with other interesting ingredients like vegetables, rice or noodles.

#### Preparing to Stir-fry

Although it is possible to stir fry in other dishes, a wok is your best tool. Its high sides enable the cook to stir food without spillage. Its construction allows you to cook quickly at high temperatures, with instant control of heat which is essential for successful stir frying.

#### Food Preparation

Slice meat and poultry into long thin strips and cube fish fillets. Remove all fat from meat and poultry and cut large vegetables into even slices or cubes.

Marinate foods for extra flavor and tenderness. Marinating times will vary for red meat, fish and or various cuts. Less tender cuts of meat should be marinated longer. Remember to always chill marinating food in the refrigerator prior to cooking.

Stir-fry meats, poultry or fish first. Next, add hard vegetables like carrots. Then continue with softer vegetables like snowpeas and peppers. To ensure even cooking, continually stir and toss the food in the wok using a wooden spoon or spatula.

#### Tips for Stir-frying

Place a wok on a Cooking Grid in the path of direct infrared heat. Add only a small amount of food at a time to ensure fast cooking and also to allow the wok to reheat between ingredients.

### DEEP-FRYING TECHNIQUES

A wide variety of foods can be deep-fried outdoors on your grill, from potatoes, to seafood and chicken. Deep-frying uses a large portion of oil, preferably saturated. The outdoor location is ideal for deep-frying as smoke, grease and smells disperse in the open air instead of collecting on the ceiling of your kitchen.

#### Preparing to Deep-fry

Deep-fry on your grill using an optional cast-iron pan placed on a Cooking Grid in the path of direct infrared heat.

Fill a cooking pan no more than half full of vegetable or corn oil. Turn the grill Burners on 🔥, close Lid and preheat your grill 3 to 5 minutes. Open Lid and place cast-iron pan on the mid section of a Cooking Grid then adjust the Infrared Burners to LOW.

Check the temperature of the oil carefully with a frying thermometer or test with a cube of bread. The cube of bread should brown in about 30 seconds for most cooking needs. 350°F(177°C) is the optimal temperature for preparing the majority of deep-fried foods.

#### Food Preparation

Foods being deep-fried taste better when coated with either batter or breadcrumbs to add flavor and prevent moisture from escaping.

#### Tips for Deep-frying

Wear a flame retardant BBQ Mitt and slowly lower foods into the hot oil using a wire scoop, fry-basket or stainless steel tongs. Add only a small quantity of food to the oil, allow it to cook, then repeat with another small quantity. This ensures the oil doesn't drop in temperature. Once the food is cooked, remove it carefully and drain onto a paper towel. Turn the heat off as soon as you have finished deep-frying and allow your pan to cool. When the oil is cool, remove all remnants of fried foods by straining it through a fine metal sieve, and store it in a clean bottle for future use.

## Guide to Using the Secondary Cooking Rack

Vegetables are generally easy to cook on the grill. The Secondary Cooking Rack makes it convenient because you can still use the main cooking area while the vegetables are suspended above the grids.

Pre-cook hard vegetables by briefly boiling or microwaving them before cooking on the grill. Do not grill your vegetables wrapped in aluminum foil. Infrared heat does not cook through aluminum foil and reflective pans. To keep vegetables moist, brush them with butter or oil often.

The Secondary Cooking Rack can be used for purposes other than just the obvious. Consider using the rack for warming French bread, garlic bread, croissants or even bagels.

**Question:**

**Can I convert my grill from one fuel type to another in other words from LPG to NG or vice versa?**

**Answer:**

No, your gas grill is manufactured to exact specifications and is certified for LPG (Liquid Propane Gas) or NG (Natural Gas) use only. For your safety, conversion kits are not available, nor will we sell or otherwise provide parts or information to be used to convert your grill. Any attempt to convert your grill is dangerous and will void your warranty.

**Question:**

**Are the serial and model numbers of my grill listed somewhere for reference?**

**Answer:**

The serial and model numbers are listed on a silver CSA label placed on the grill. Depending on the grill model the silver CSA label will be located on the left or right side bowl panel underneath the side shelf, underneath the right side of the control panel, outside left or right of control panel or on the back of the grill cabinet.

**Question:**

**My grill will not light properly. Why?**

**Answer:**

Always light the Main Burner farthest from the fuel source first. This will draw gas across the manifold helping prevent air pockets which obstruct gas-flow and prevent proper grill lighting. Also try this procedure:

1. Turn gas off at source and turn Control Knobs OFF. Wait at least 5 minutes for gas to clear, then retry.
2. If your grill still fails to light, turn the Burner Control Knob(s) and gas source OFF and conduct a leak test of ALL gas connections and gas sources as explained in the Use and Care section of this manual.
3. If no leaks are detected, wait 5 minutes for any gas to clear and repeat the lighting procedure.

**Question:**

**If my ignitor or battery is not working how can I light my grill manually? And - Why would I need the silver lighting stick that hangs from the side of my grill?**

**Answer:**

If your ignition fails to work or your battery needs replacing, you can light your grill using the Manual Lighting Stick. The Lighting Stick is designed to hold a paper match and allows you to safely insert a match through the Cooking Grid without getting close to the Burner. To light your gas grill manually, insert a paper match into the Manual Lighting Stick and follow steps 1 through 5 of the Basic Lighting Procedures. Then, light the match and place the Lighting Stick through the Cooking Grid. Turn the correlated main Burner Control Knob to the  setting to release gas. The Burner should light immediately.



## WARNING



**Never** lean over the grill cooking area while lighting your gas grill. Keep your face and body a safe distance (at least 18 inches) from the front of grill when lighting your grill by match.

**Question:**

**Sometimes I hear a humming sound coming from my regulator. What causes this? And - My grill has a low flame and sometimes will not light. Why?**

**Answer:**

The humming sound is gas flowing through the regulator. A low volume of sound is normal and will not interfere with the operation of your grill. Loud or excessive regulator humming and/or low flow and intermittent lighting may be caused by the regulator's excess gas flow device. Opening the tank valve all the way or too quickly is what triggers the regulator's safety device to restrict gas flow, preventing excess gas flow to your grill. Lighting the main Burner farthest from the fuel source every time will help eliminate air pockets in the manifold. Note: This procedure should be done every time a new LP Gas tank is connected to your grill.

- Turn all Control Knobs to the OFF position.
- Turn off the LP Gas tank at the tank valve. For Natural Gas shut off NG valve.
- Disconnect regulator from LP Gas tank. For Natural Gas disconnect regulator from 12 ft. Natural Gas Hose.
- Let unit stand for 5 minutes.
- Reconnect regulator to the LP Gas tank. For Natural Gas reconnect regulator to 12 ft. Natural Gas Hose.
- Open grill Lid.
- Turn the tank valve slowly ¼ of one turn. For Natural Gas open Shut Off valve.
- Light main Burner farthest from fuel source.
- Turn the tank valve slowly one more ¼ of one turn for ½ of one complete turn.
- Continue to light Burners moving towards the fuel source.
- Do not turn tank valve more than ½ of one turn on LPG models.

**Question:**

**Where do I use my grill for safer operation and better performance?**

**Answer:**

- Strong winds and low temperatures can affect the heating and performance of your gas grill so factor in these elements when positioning your grill outdoors for cooking.
- In windy conditions, always position the front of the grill to face oncoming wind to reduce heat and smoke blowing in your face, and to prevent potential hazards to yourself and the grill.
- Use your grill at least 3 feet away from any wall or surface.
- Use your grill at least 3 feet away from combustible objects that can melt or catch fire (ex: vinyl or wood siding, fences and overhangs) or sources of ignition including pilot lights on water heaters and live electrical appliances.
- Never** use this gas appliance on a balcony, deck, or patio above the ground floor of your home.
- Never** use your gas grill in a garage, porch, shed, breezeway or any other enclosed area.
- Never** obstruct the flow of ventilation air around your gas grill housing.

**Question:**

**The Regulator and Hose supplied with my gas grill does not fit the older LP Gas tank I've used for years. Why not?**

**Answer:**

The U.S. Government regulates gas appliances and LP Gas tanks. When regulations are changed the LP Gas tank fittings are altered to insure compliance. If your LP Gas tank does not fit the Regulator and Hose supplied with your new grill, the tank is outdated and must be replaced. Note: Effective April 1, 2002 all LP Gas tanks sold must include an "OPD" Overfill Prevention Device. The OPD tanks are identified by their triangular-shaped valve wheel. This internal device prevents the LP Gas tank from being overfilled. Tanks without an OPD valve can not be refilled.

After every use (after your grill has cooled down), wipe stainless surfaces with a soft, soapy cloth or sponge then rinse with water. Be sure to remove all food particles, sauces or marinades from stainless steel because these can be highly acidic and damaging to stainless surfaces.

Never use abrasive cleaners, scrubbers or stiff wire brushes of any type on your grill. Use a heat resistant Stainless Steel Cleaner and rub or wipe in the direction of the stainless steel grain or polish lines. Do not polish against the grain.

**Question:**

**What causes grill parts to rust and what effect does it have on my grill?**

**Answer:**

Rusting is a natural oxidation process and will not affect the short term performance of your grill.

To slow the rusting process on Cooking Grids, we recommend greasing the grids before and after each cookout. Use a brush to apply a thin layer of cooking oil or vegetable shortening onto each grid. We do not suggest spray type oils unless they are specified for high-temperature cooking. If your Cooking Grids are Porcelain coated, be sure to coat the entire cooking surface including edges and any areas with chipped porcelain.

Routine care and maintenance is required to preserve the appearance and corrosion resistance of stainless steel. The fact is stainless steel can corrode, rust and discolor under certain conditions. Rust is caused when regular steel particles in the atmosphere become attached to the stainless steel surface. Steel particles can also become attached to your grill if you use steel wool or stiff wire brushes to clean the grill instead of non-abrasive cloth, sponge or nylon cleaning tools. In coastal areas rust pits can develop on stainless surfaces that cannot be fully removed. Bleach and other chlorine based solutions used for household and pool cleaning can also cause corrosion to stainless steel.

Weathering, extreme heat, smoke from cooking and machine oils used in the manufacturing process of stainless steel can cause stainless steel to turn tan in color. Although there are many factors which can affect the surface appearance of stainless steel, they do not affect the integrity of the steel or the performance of the grill. To help maintain the finish of stainless steel follow these cleaning procedures for the best results:

## Grand Hall Limited Warranty

Grand Hall will warrant to the ORIGINAL PURCHASER of this product that it will be free of defects in material and workmanship for set periods below from the date of purchase when used under normal outdoor use and correct assembly:

Cooking Grids - 5 Year Limited Warranty(No rust through or burn through)

Infrared burners - 3 Year Limited Warranty

Valves and Plastic Components - 2 Year Limited Warranty

Electronic Components - 1 Year Limited Warranty

Paint coatings - 2 Year Limited Warranty for color fading or peeling

All other s/s parts - 3 Year Limited Warranty

All remaining parts - 2 Year Limited Warranty

Grand Hall will require reasonable proof of your date of purchase. Therefore, you should send in the owner registration card or register online at [www.grandhall.com](http://www.grandhall.com). Save your receipt in case it is required as proof of purchase.

This Limited Warranty is limited to replacement of parts at Grand Hall's option that proved to be defective under normal use and service.

Grand Hall may require the return of defective parts for examination before issuing replacement parts. If you are required to return defective parts, shipping charges must be prepaid. No returns will be accepted without prior authorization from Grand Hall.

Upon examination and to Grand Hall's satisfaction, if the original part is proven defective, Grand Hall may approve your claim and elect to replace such parts without charge. You will be charged for shipping and handling of the replacement parts.

This Warranty does not cover any failures or operating difficulties due to accident, abuse, misuse, alteration, misapplication, vandalism, improper installation, maintenance, operation or service, as set out in the Operator's Manual.

This Warranty does not cover cosmetic wear and tear such as scratches, dents, corrosion or discoloration caused by weather, heat, chemicals, paint loss, or surface rust. Deterioration or damage due to severe weather conditions such as hail, hurricanes, earthquakes, tsunami, tornadoes, Act of God or terrorism is not covered by this Limited Warranty.

To Obtain Warranty:

Call 1-877-934-7455

Monday-Friday 8:00AM-4:30PM CST

Warranty Restrictions:

- This Warranty is non-transferable and is void if product is used for commercial or rental purposes.
- This Warranty applies only when the product is used in the United States or Canada.
- This Warranty gives you specific legal rights, and you may also have other rights which vary from state to state.

Manufacturer:

Grand Hall Enterprise Co., Ltd.

9th Fl., No. 298, Rueiguang Rd., Neihu,

Taipei, Taiwan (114)