



MEMBER'S MARK.

Traditional Barrel BBQ Grill

Owner's Manual

Assembly and Operating Instructions

Model # CG2036001-MM

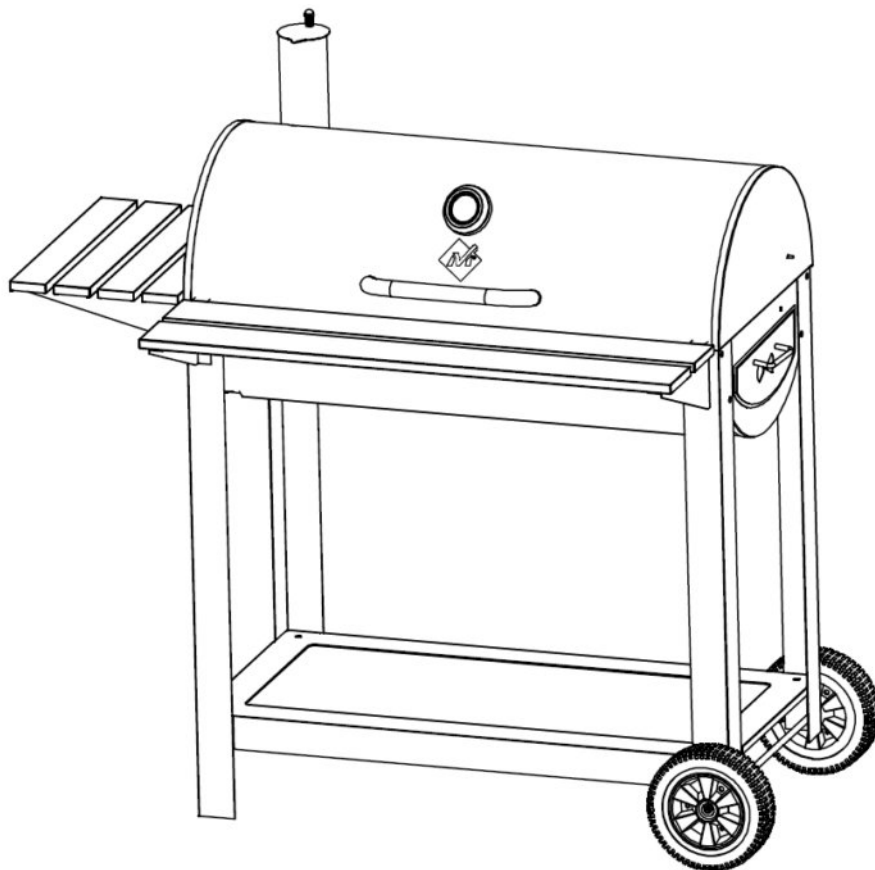

Tools required for assembly: (Not Included) Pliers, Philips & Flathead Screwdrivers, Adjustable Wrench.

Keep this manual for future reference.



WARNING



- Only use this grill on a hard, level, non-combustible, stable surface (concrete, ground, etc.) capable of supporting the weight of the grill. Never use on wooden or other surfaces that could burn.
 - DO NOT use grill without charcoal ash tray in place. DO NOT attempt to remove charcoal ash tray while coals are hot.
 - When grill is in use, keep clearance of 36" between the hot grill and any combustible materials, such as bushes, trees, wooden decks, wooden fences, buildings, etc. Do not place hot grill under roof overhang or in any other enclosed area.
 - For outdoor use only. Do not operate grill indoors or in an enclosed area.
 - For household use only. Do not use this grill for other than its intended purpose.
 - We recommend the use of a Charcoal chimney starter to avoid the dangers associated with charcoal lighting fluid. If you choose to use charcoal lighting fluid, only use lighting fluid approved for lighting charcoal. Carefully read manufacturer's warnings and instructions on the charcoal lighting fluid and charcoal prior to the use of their product. Store charcoal lighting fluid safely away from grill.
 - When using charcoal lighting fluid, allow charcoal to burn with grill lid and doors open until covered with a light ash (approximately 20 minutes). This will allow charcoal lighting fluid to burn off. Failure to do this could trap fumes from charcoal lighting fluid in grill and may result in a flash fire or explosion when lid is opened.
 - Never use charcoal that has been pre-treated with lighting fluid. Use only a high grade plain charcoal or charcoal / wood mixture.
 - Do not use gasoline, kerosene or alcohol for lighting charcoal. Use of any of these or similar products could cause an explosion possibly leading to severe bodily injury.
 - Never add charcoal lighting fluid to hot or even warm coals as flashback may occur causing severe burns.
 - Place grill in an area where children and pets cannot come into contact with unit. Close supervision is necessary when grill is in use.
 - Do not leave grill unattended when in use.
 - When adding charcoal and / or wood, use extreme caution and follow instructions in "Adding Charcoal / Wood During Cooking" section of this manual.
 - Do not store or use grill near gasoline or other flammable liquids, gases or where flammable vapors may be present.
 - Do not store lighter fluid or other flammable liquids or materials under the grill.
 - Use caution when adjusting charcoal grate height, use oven mitt. Handle will be hot when in use.
 - Never raise or lower charcoal grate when water smoking as hot water may splash on to coals creating a burst of hot steam and coals.
- Grill is hot when in use. To avoid burns:
- DO NOT attempt to move the grill.
 - Wear protective gloves or oven mitts.
 - DO NOT touch any hot grill surfaces.
 - DO NOT wear loose clothing or allow hair to come in contact with grill.



WARNING



- When grilling, grease from meat may drip into the charcoal and cause a grease fire. If this should happen close lid to suffocate the flame. Do not use water to extinguish grease fires.
- Use caution when opening the lid, keep hands, face and body a safe distance away. Flash flare ups may occur when air comes into contact with fire or hot coals.
- Never place more than 6 pounds (2.7 kg) on side and front tables. Do not lean on the side tables. Always ensure side tables are securely fastened.
- Do not allow charcoal and/or wood to rest on the walls of grill. Doing so will greatly reduce the life of the metal and finish of your grill.
- Use caution during assembly and while operating your grill to avoid scrapes or cuts from sharp edges of metal parts. Use caution when reaching into or under grill.
- When opening lid, be sure lid is fully opened and secure to prevent lid from closing unexpectedly.
- In windy weather, place grill in an outdoor area that is protected from the wind.
- Close lid to suffocate flame.
- Never leave coals and ashes in grill unattended, before grill can be left unattended, remaining coals and ashes must be removed from grill. Use caution to protect yourself and property, carefully place remaining coals and ashes in a non-combustible metal container and saturate completely with water, allow coals and water to remain in metal container 24 hours prior to disposing.
- Extinguished coals and ashes should be placed a safe distance from all structure and combustible materials.
- With a garden hose completely wet the surface beneath and around grill to extinguish any ashes, coals or embers which may have fallen during the cooking or cleaning process.
- After each use, clean the grill thoroughly and apply a light coat of vegetable oil to prevent rusting. Cover the grill to protect it from excessive rusting.
- Use caution when lifting or moving grill to prevent strains and back injuries.
- We advise that a fire extinguisher be on hand. Refer to your local authority to determine proper size and type of fire extinguisher.
- Store the grill out of reach of children and in a dry location when not in use.
- Do not attempt to service grill other than normal maintenance as explained in "After-Use Safety" and "Proper Care & Maintenance" sections of this manual.
- Properly dispose of all packaging material

Use caution and common sense when operating your grill,

Failure to adhere to safety warning and guidelines in this manual could result in bodily injury or property damage.

Save this manual for future reference.

ASSEMBLY INSTRUCTIONS

THANK YOU FOR PURCHASING THIS BARREL GRILL

Read all safety warnings & assembly instructions carefully before assembling or operating your grill.

For missing parts, please call customer service at CustomerService@Rankam.com or at 888-837-1380 (U.S. only)

(Proof of purchase will be required.)

Inspect contents of the box to ensure all parts are included and undamaged.

We recommend two people for assembly of this grill.



The following tools are required for assembly and are not included:

- Pliers
- Philips & Flathead Screwdrivers
- Adjustable Wrench

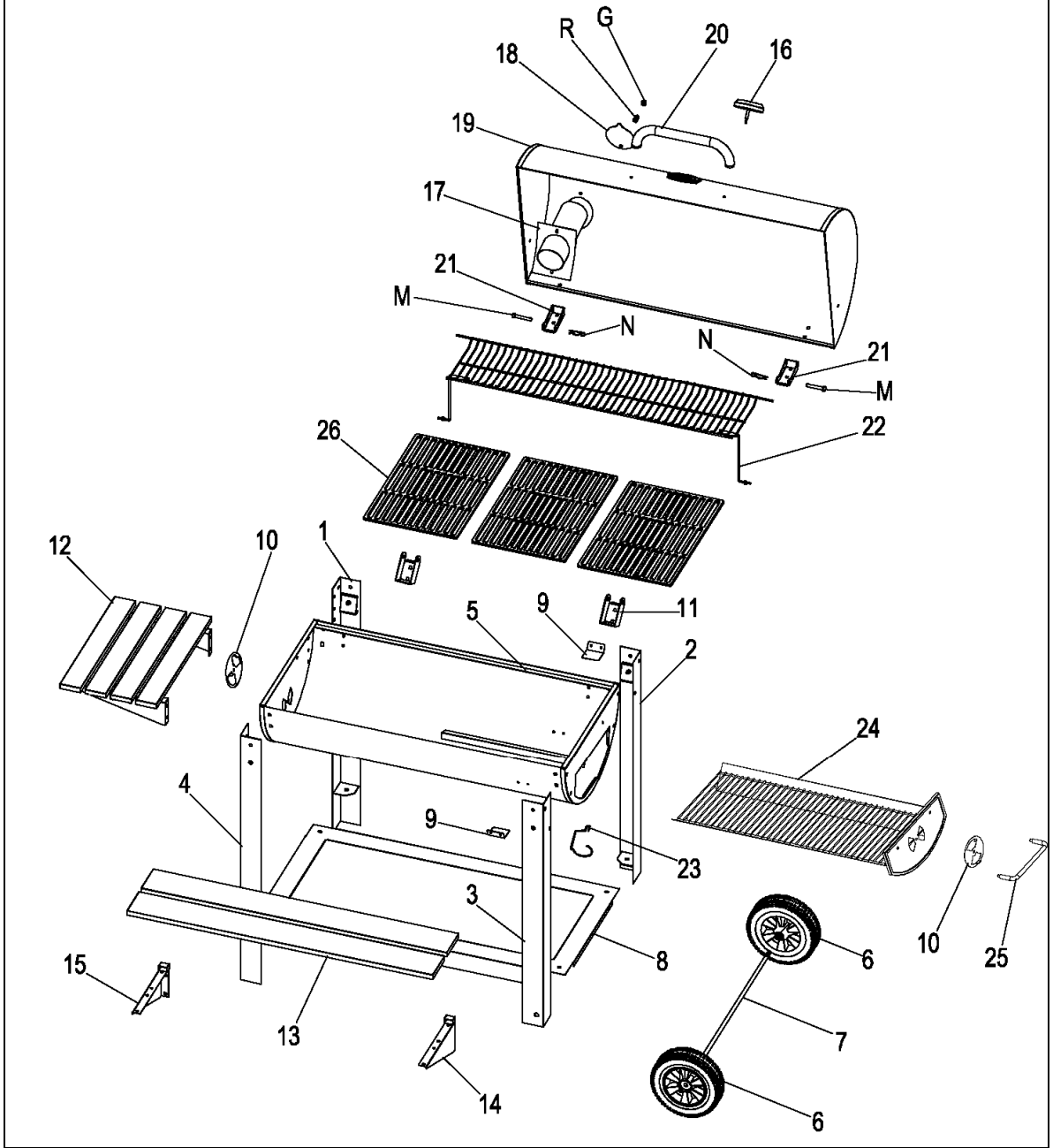
Product Diagram

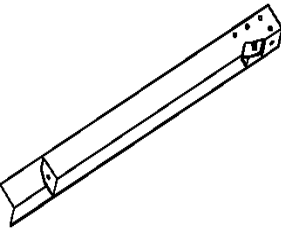
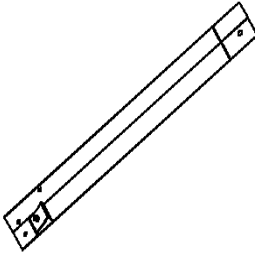
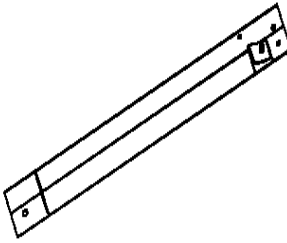
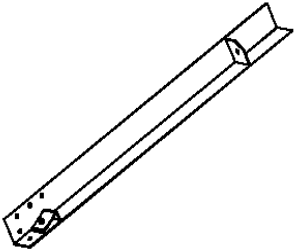
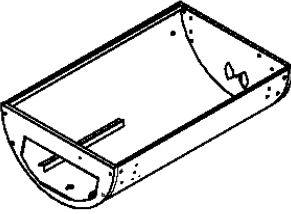
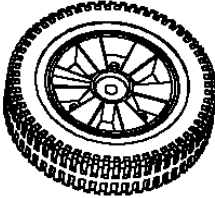
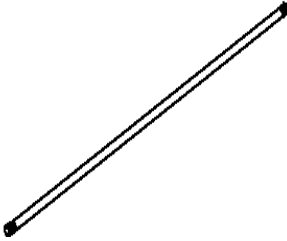
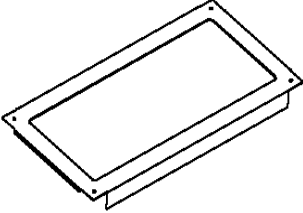
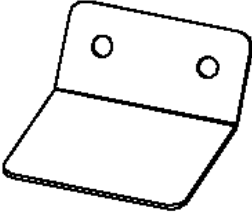

Component List

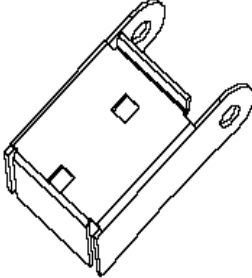
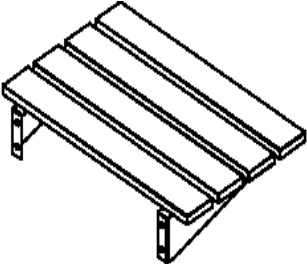
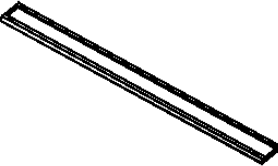
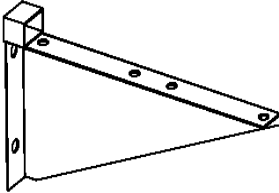
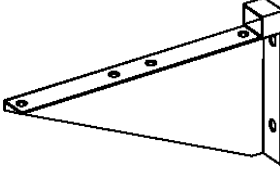
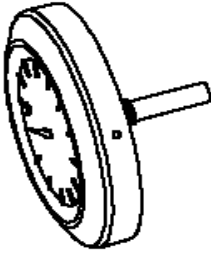

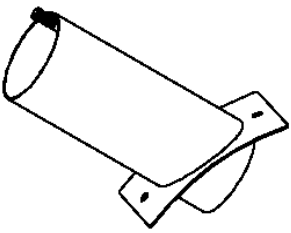
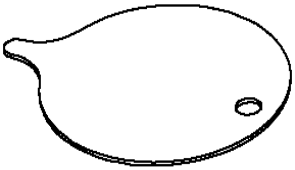
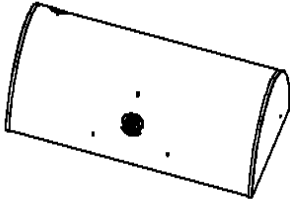
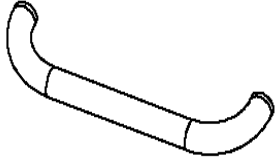
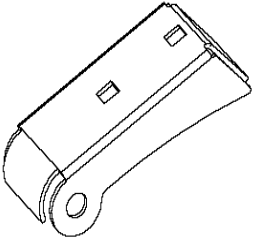
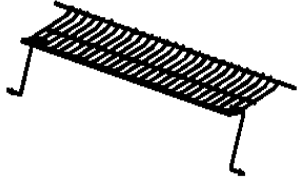
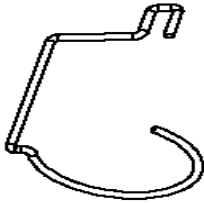
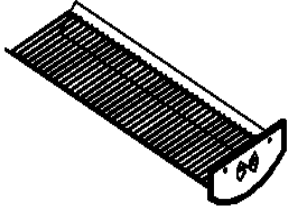
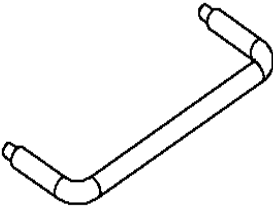
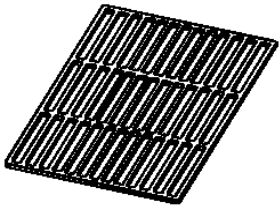













<p>1. Left rear leg</p>  <p>1 pc</p>	<p>2. Right rear leg</p>  <p>1 pc</p>	<p>3. Right front leg</p>  <p>1 pc</p>	<p>4. Left front leg</p>  <p>1 pc</p>
<p>5. Grill Body</p>  <p>1 pc</p>	<p>6. Wheel</p>  <p>2 pcs</p>	<p>7. Axle</p>  <p>1 pc</p>	<p>8. Bottom rack</p>  <p>1 pc</p>
<p>9. Charcoal Grate Clip</p>  <p>2 pcs</p>	<p>10. Air Vent</p>  <p>2 pcs</p>	<p>11. Lower Hinge</p>  <p>2 pcs</p>	<p>12. Side Shelf</p>  <p>1 pc</p>
<p>13. Front table slate</p>  <p>2 pcs</p>	<p>14. Right front table support</p>  <p>1 pc</p>	<p>15. Left front table support</p>  <p>1 pc</p>	<p>16. Temperature Gauge</p>  <p>1 pc</p>

<p>17. Chimney</p>  <p>1 pc</p>	<p>18. Chimney Cover</p>  <p>1 pc</p>	<p>19. Lid</p>  <p>1 pc</p>	<p>20. Lid Handle</p>  <p>1 pc</p>
<p>21. Lid Hinge</p>  <p>2 pcs</p>	<p>22. Warming Rack</p>  <p>1 pc</p>	<p>23. Grease cup holder</p>  <p>1 pc</p>	<p>24. Charcoal Grate</p>  <p>1 pc</p>
<p>25. Charcoal Grate Handle</p>  <p>1 pc</p>	<p>26. Cooking Grid</p>  <p>3 pcs</p>		

STOP! DO NOT RETURN TO RETAILER.

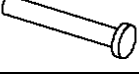
For assembly assistance, missing or damaged parts, please contact customer service at CustomerService@Rankam.com or at 1-888-837-1380.

Hardware List

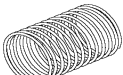
A		Bolt (M8X15)	4 pcs
B		Bolt (M8X12)	8 pcs
C		Bolt (M6X30)	8 pcs
D		Bolt (M6X12)	30 pcs
E		Lock Nut (M10)	2 pcs
F		Nut (M8)	16 pcs
G		Cap Nut (M8)	1 pc
H		Nut (M6)	10 pcs
I		Lock Nut (M6)	10 pcs
J		Cap Nut (M6)	2 pcs
K		Cap Nut (M5)	2 pcs
L		Flange Nut (M6)	2 pcs
M		Hinge Pin	2 pcs
N		Cotter Pin	2 pcs
O		Lid Handle Insulation Washer	2 pcs
P		Wheel Washer	2 pcs
Q		Charcoal Grate Handle Insulation Washer	2 pcs
R		Spring	1 pc

Assembly Procedures

Step 1. Assemble Left rear leg (1) on grill body (5) by using bolt M8x15(A), bolt M6x12(D) and nut M8 (F), and also on the side by bolt M8x12 (B) and nut M8 (F). Then assemble Left front leg (4) on grill body (5) by bolt M8x12(B) and nut M8 (F). On each leg there is a weld bolt and they will go through the grill body (5) as well. Then tighten them with nut M8 (F).

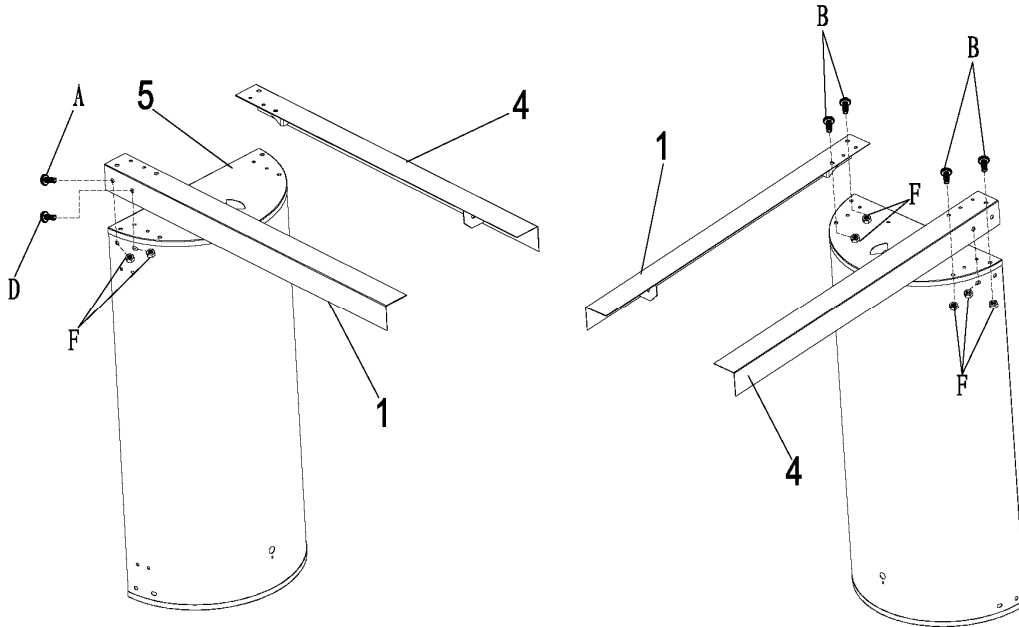

Assembly of legs on the left hand side of the grill

Step 2. Assemble Right rear leg (2) on grill body (5) by using bolt M8x15(A), bolt M6x12 (D) and nut M8(F), and also on the side by bolt M8x12 (B) and nut M8(F). Then assemble Right front leg (3) on grill body (5) by bolt M8x12 (B) and nut M8(F). On each leg there is a weld bolt and they will go through the grill body (5) as well. Then tighten them with nut M8(F).

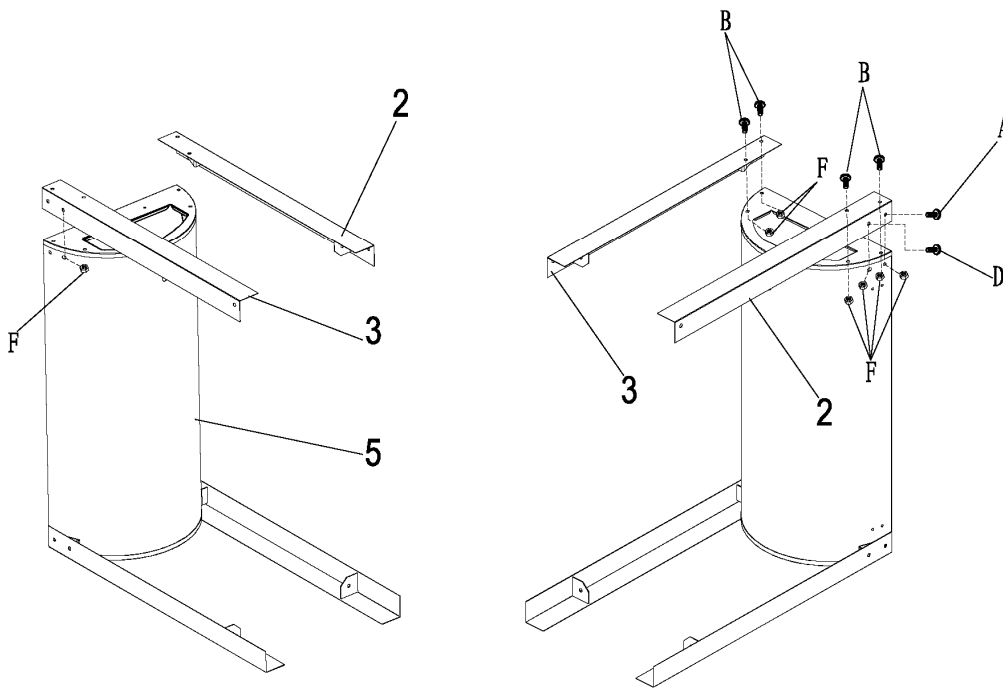

Assembly of legs on the right hand side of the grill

Step 3. Place the Axle (7) go through the hole on Right front leg (3) and Right rear leg (2). Then assemble the Wheels (6) to Axle (7) by insert installing Wheel washer (P) with lock nut M10 (E).

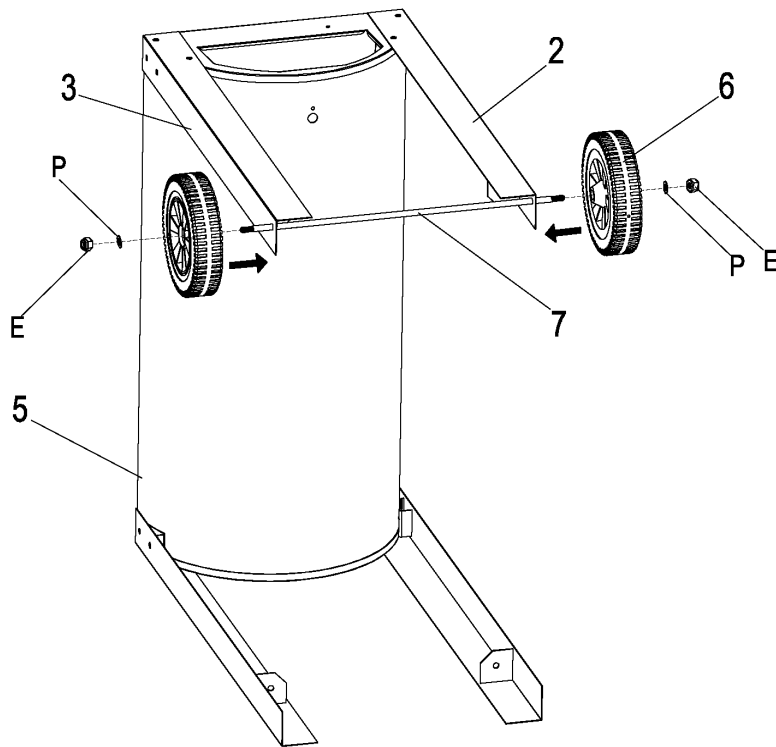

Step 4. Place the Bottom Rack (8) under the Grill Body and tighten it with bolt M6x12 (D) to each leg's bracket.. Mount the Charcoal Grate Clip (9) with Bolt M6x12 (D) and Nut M6 (H)

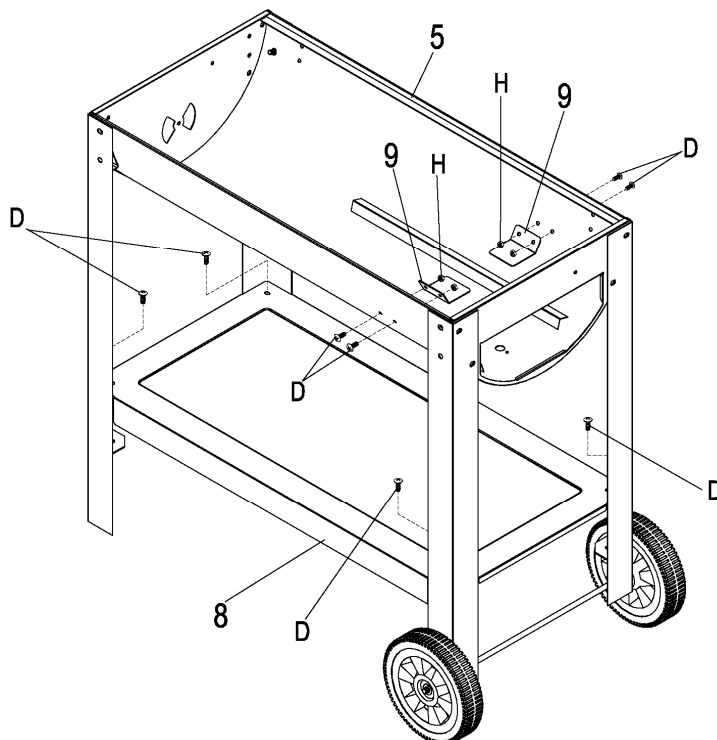

Step 5. Assemble Air Vent (10) on the left side panel of Grill body (5) by insert bolt M6x12(D) and lock nut M6 (I). Assemble the Lower Hinges (11) on Grill Body (5) by bolts M6x30 (C) and lock nuts M6 (I). Do not tighten them at this moment.

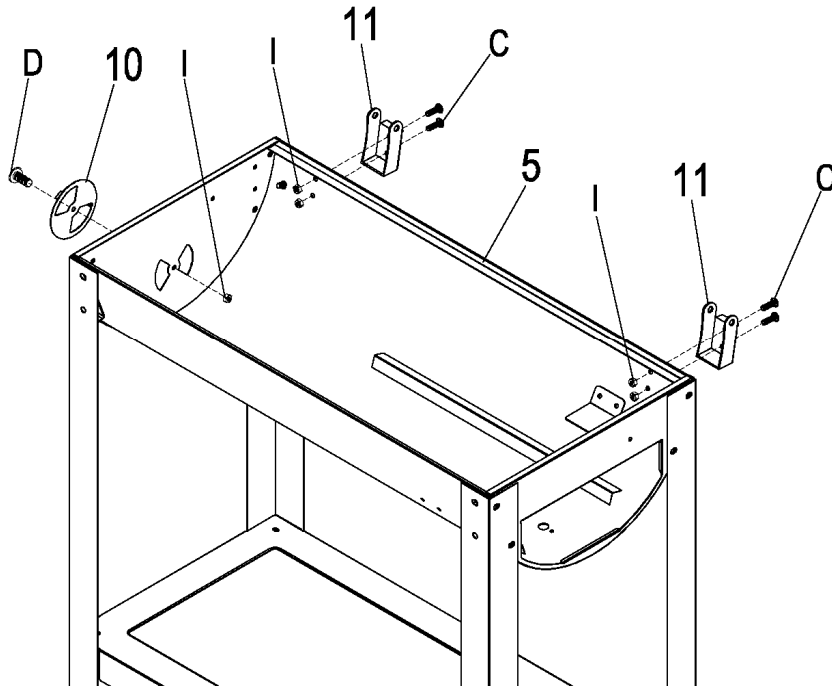

Step 6. Assemble the Side Shelf (12) to Left legs (1) and (4), and Grill body (5) by bolt M6x12 (D) and nut M6 (H).

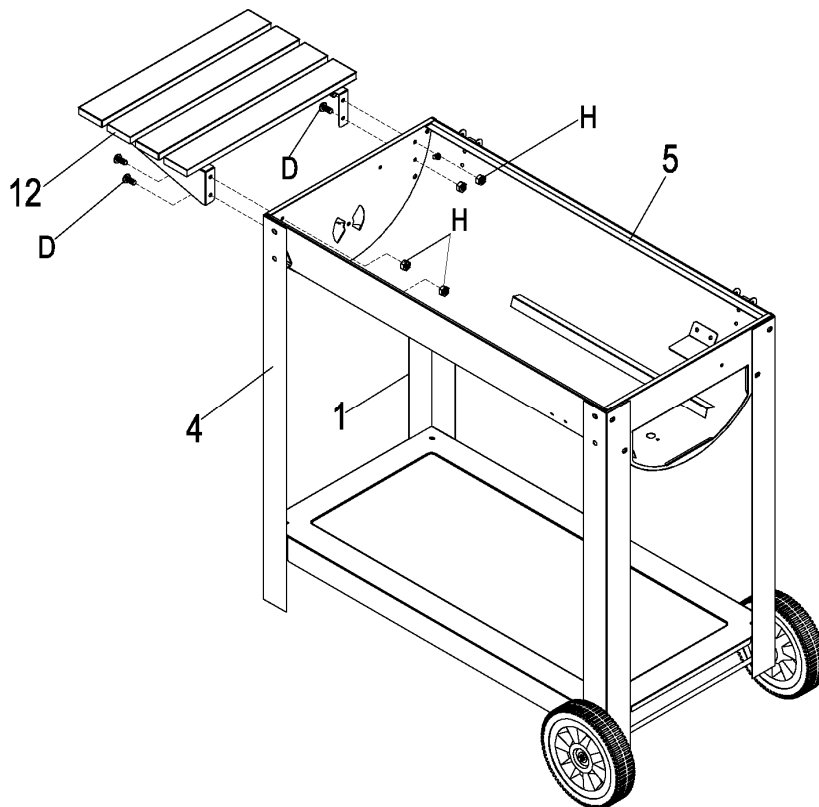

Step 7. Assemble the Left Front Table Support (15) and Right Front Table Support (14) to Front Table Slats (13) with bolt M6x12 (D) and tighten them.

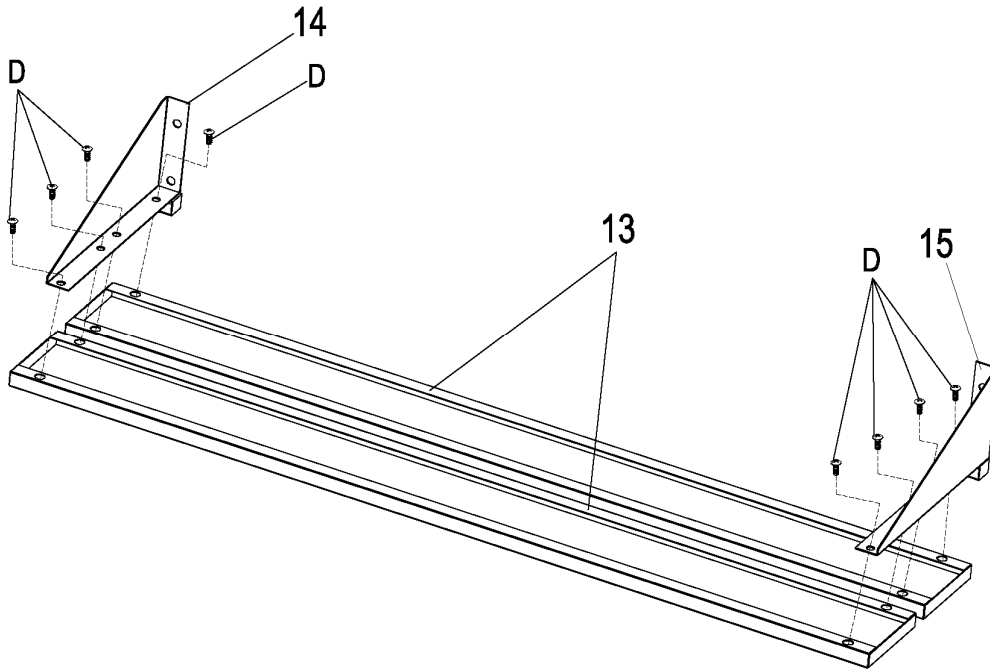

Step 8. Attach Front Table to Grill Body by using bolt M8x15 (A) - upper, bolt M6x12 (D) – lower and Nut M8 (F), and also bolt (D) to the front legs as well.

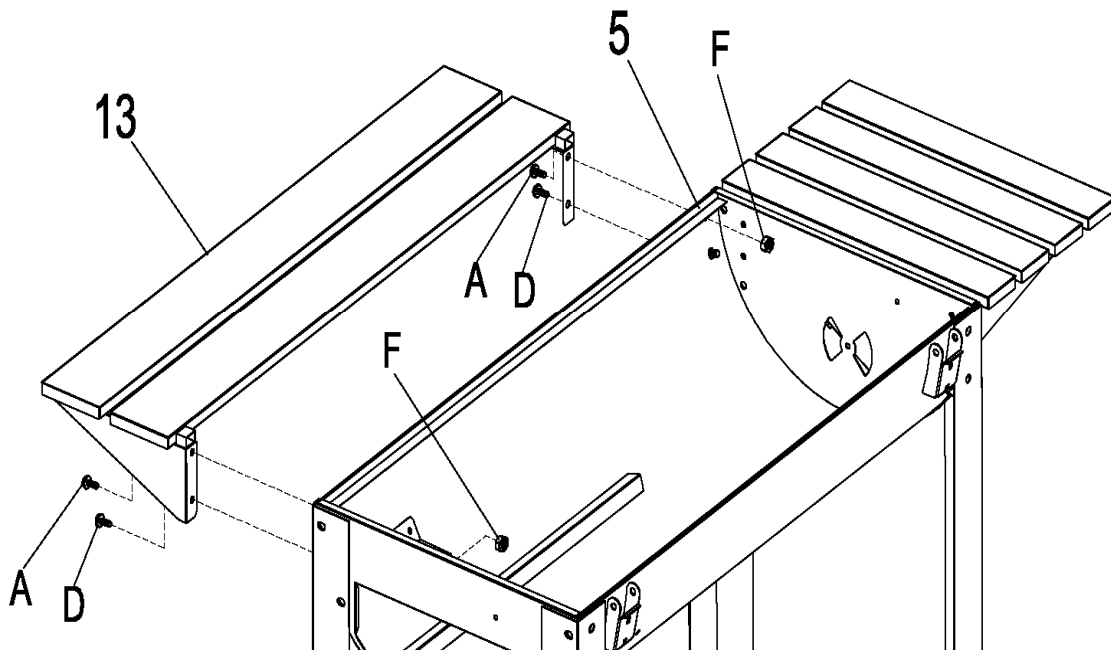

Step 9. Assemble the Lid Hinge (21) on Lid (19) by bolt M6x30 (C) and lock nut M6 (I). Do not tighten them at this moment.

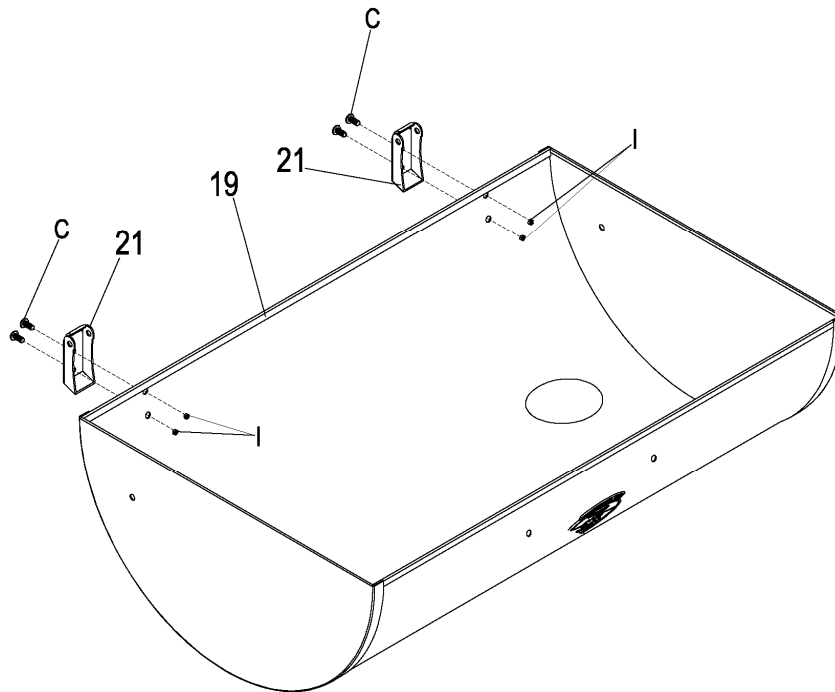

Step 10. Attach the Chimney (17) onto the Lid (19) with bolt M6x12 (D) and nuts M6 (H). Place Chimney Cover (18) on Chimney (17) by Spring (R) and cap nut M8 (G). Assemble the Lid handle (20) by bolt M6x12 (D) and place Lid Handle Insulating washers (O) in between Lid (19) and Handle (20). Unscrew the nut from Temperature Gauge (16) and attach the Temperature Gauge (16) to middle front of Lid (19) and tighten with the nut. Do not tighten thermometer by turning thermometer head; tighten rear bolt to moderate tension. DO NOT OVER TIGHTEN DAMAGE MAY OCCUR TO THERMOMETER.

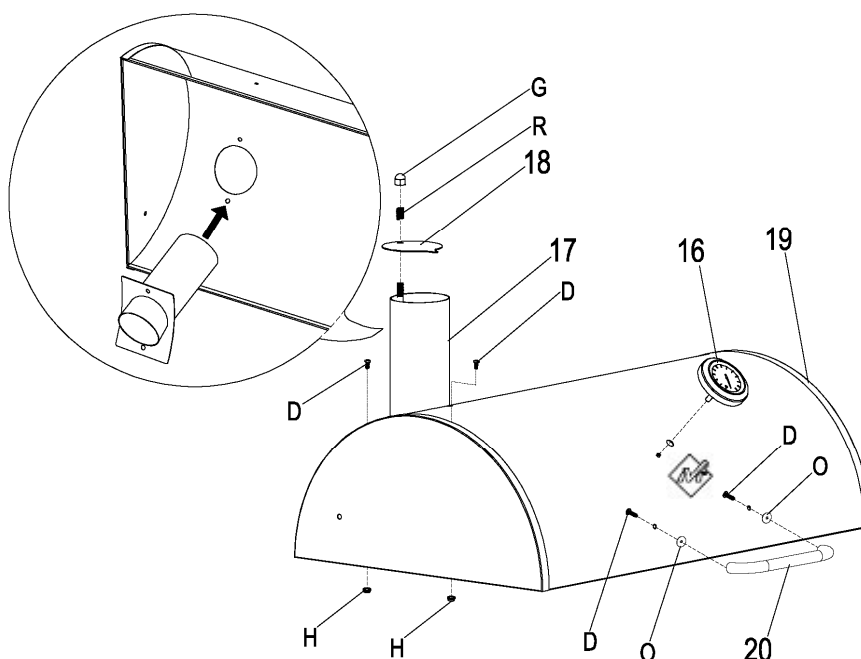

Step 11. Align the Lid to Grill Body (5) and let Hinge pin (M) to go through upper and lower hinges and lock it with Cotter pins (N). Then tighten the hinge bolts at this moment.

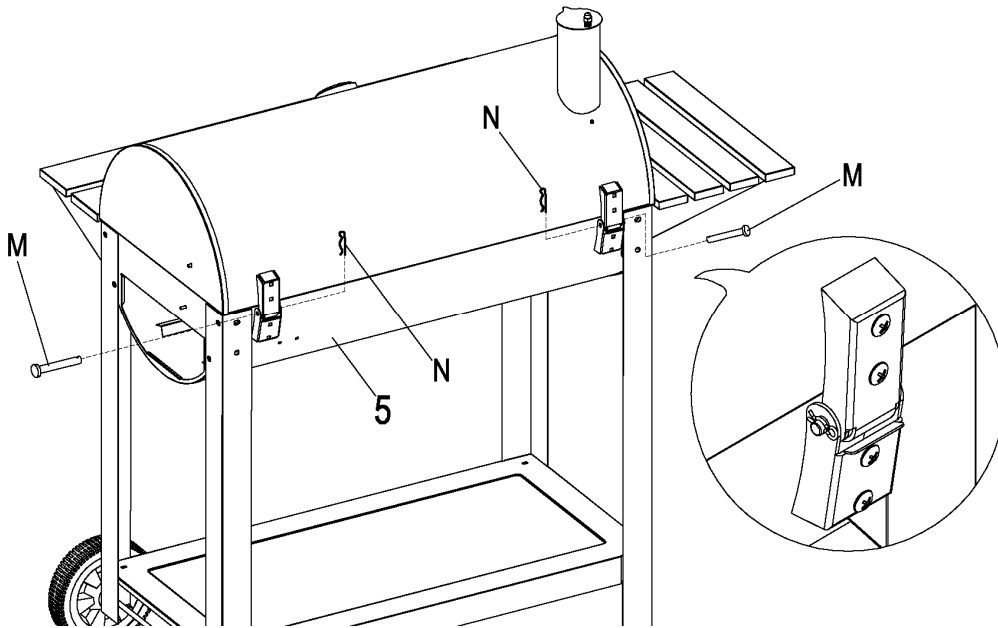

Step 12. Assemble the Warming Rack (22) to the Lid (19) and Grill Body (5), and tighten the wire end with cap nut M6 (J) and Cap nut M5 (K). Hang the Grease Cup Holder (23) to the right side of Grill Body (5)

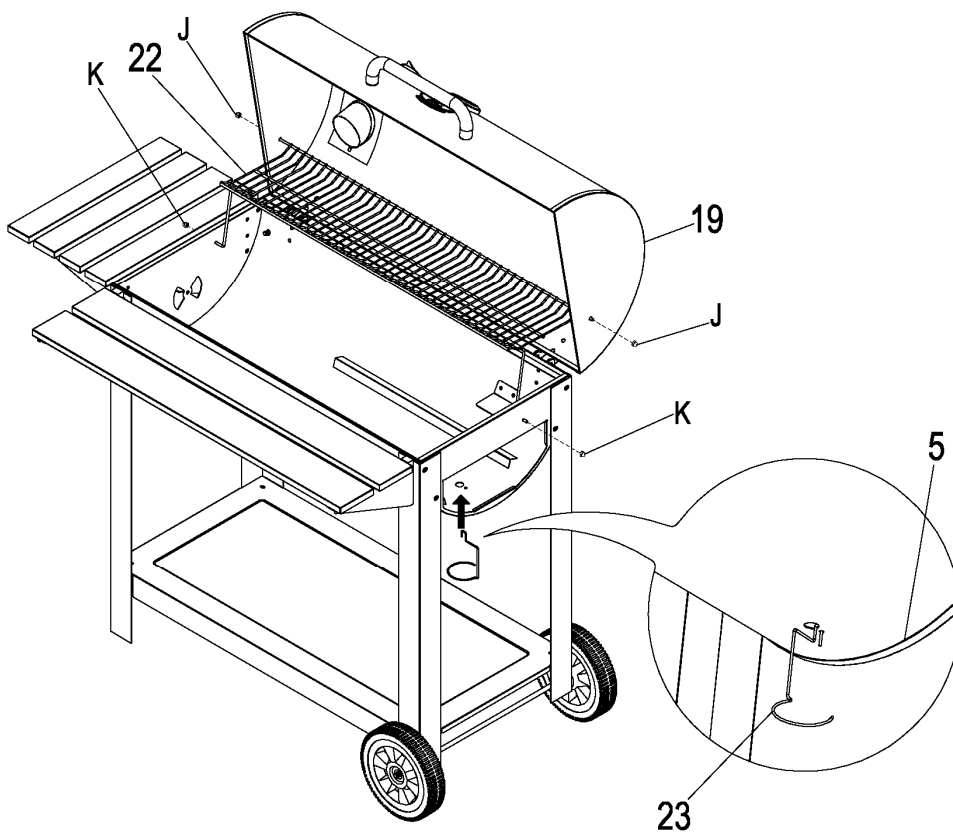

Step 13. Assemble the Air Vent (10) on the door panel of Charcoal Grate (24) with bolt M6x12 (D) and lock nut M6 (I). Assemble the Charcoal Grate Handle (25) by Flange nut M6 (L) and place Charcoal Grate Insulation washer (Q) in between Charcoal Grate Handle (25) and door panel of Charcoal Grate (24).

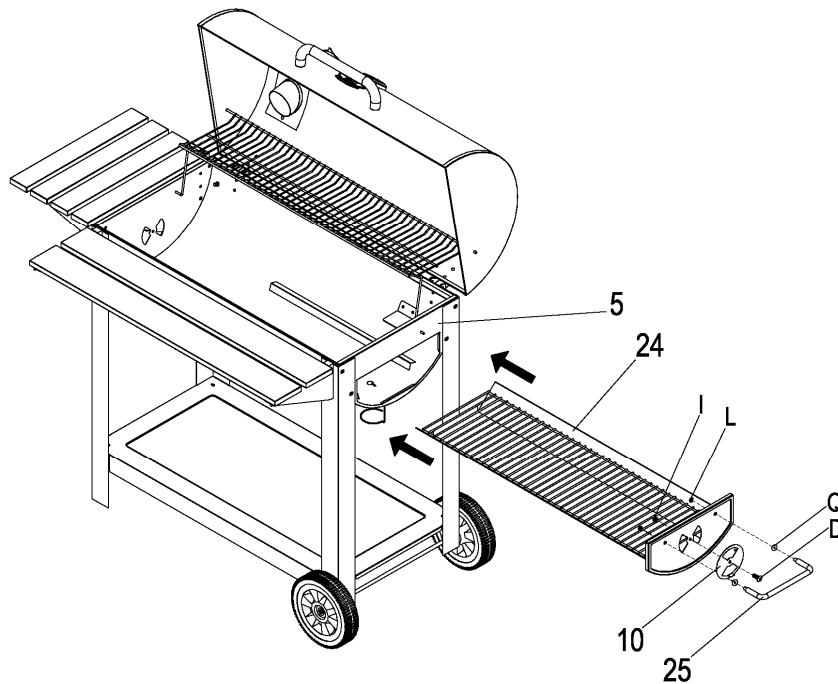

Step 14. PLACE CHARCOAL GRATE INTO GRILL BODY : (I) Slide Charcoal Grate (24) inside the Grill Body (5) a bit. (II) Lift up the Charcoal Grate slightly to let stopper at the bottom of Charcoal Grate to slide over the latch on the Grill Body. (III) Glide the Charcoal Grate smoothly towards the Grill Body. (IV) Keep pushing the Charcoal Grate in until the back lock at the bottom of Charcoal Grate hooks up to the latch on the inside of Grill Body. See below illustration Step 1 – Step 4

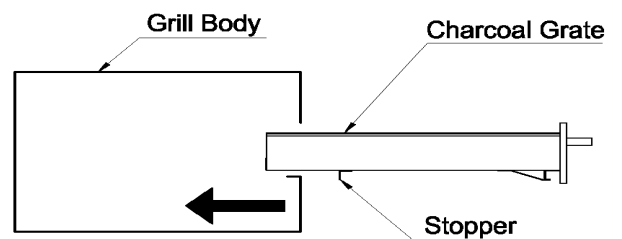
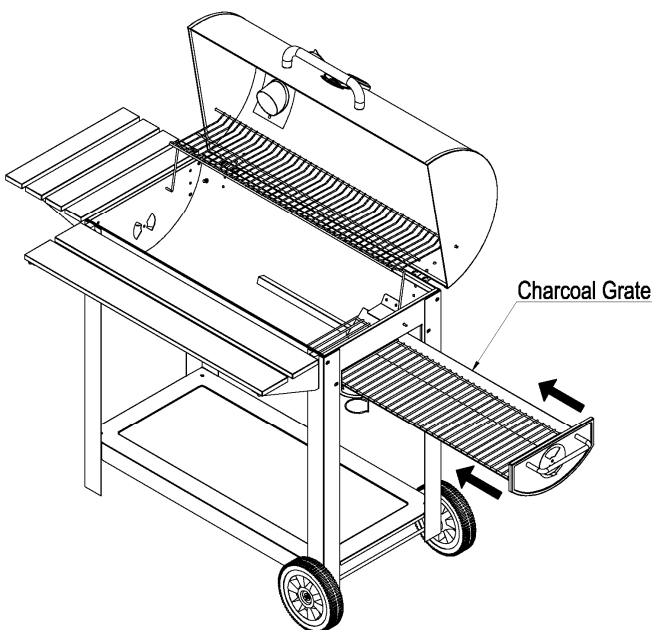

Step: 1

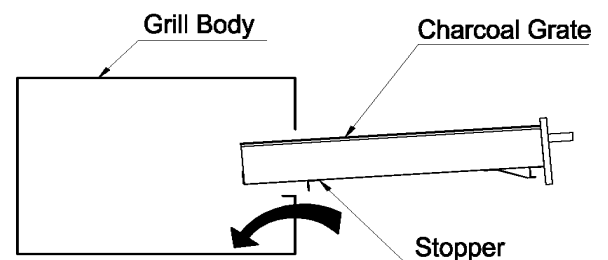

Step: 2

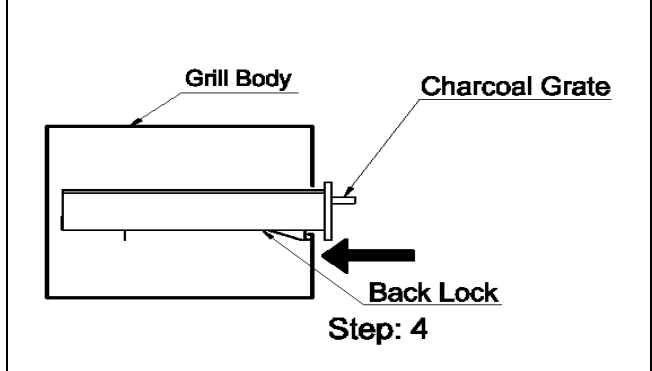
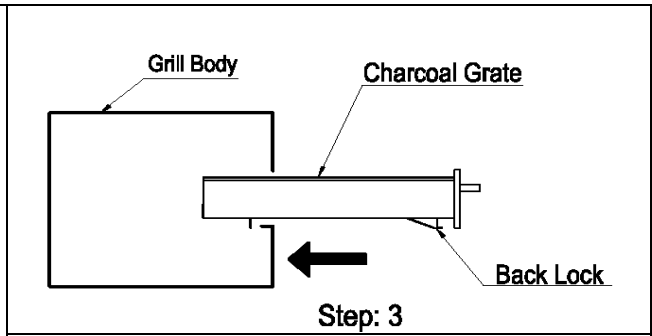
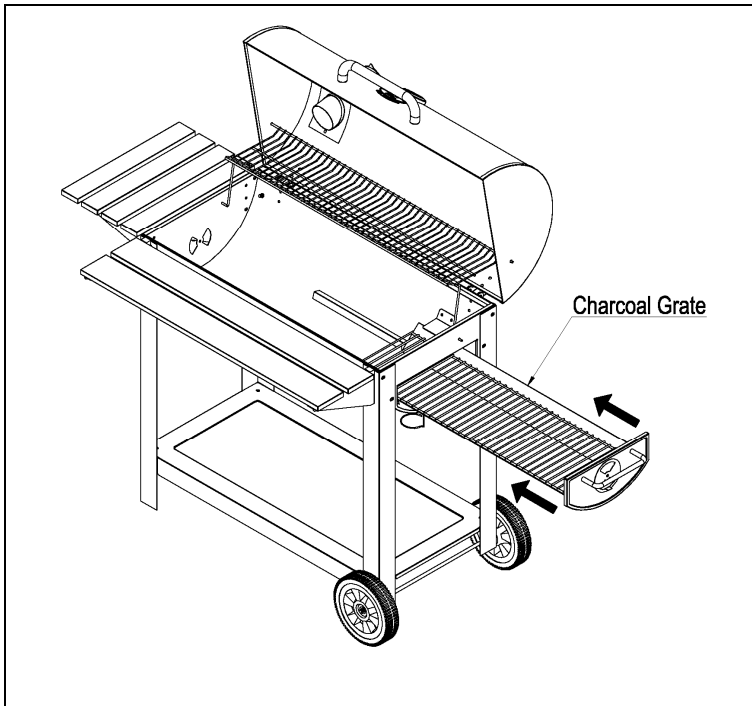

Step 15. ADD CHARCOAL WHEN IN USE : (I) Lift up the Charcoal Grate (24). (II) Pull the whole Charcoal Grate out to let the back lock at the bottom of Charcoal Grate skip over the latch on the Grill Body. (III) Hold and keep pulling Charcoal Grate out horizontally until the stopper at the bottom of Charcoal Grate hooks up to the latch on the inside of Grill Body, then add charcoal. See below illustration Step 1 – Step 3. **NOTE:** Always close the Air-Vent and wear mittens/gloves before removing the Charcoal Grate

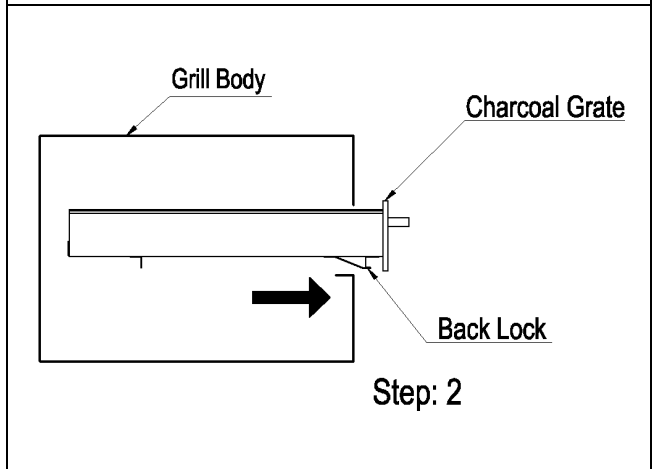
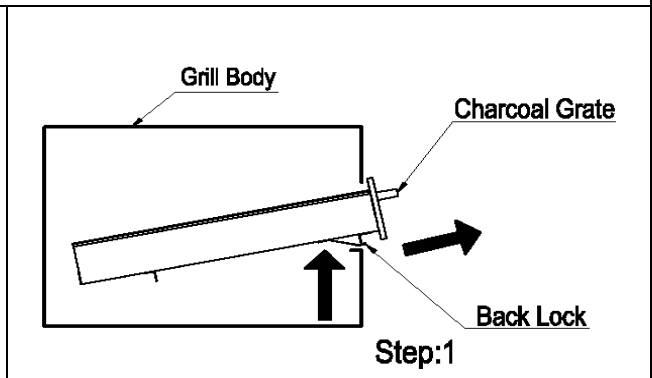
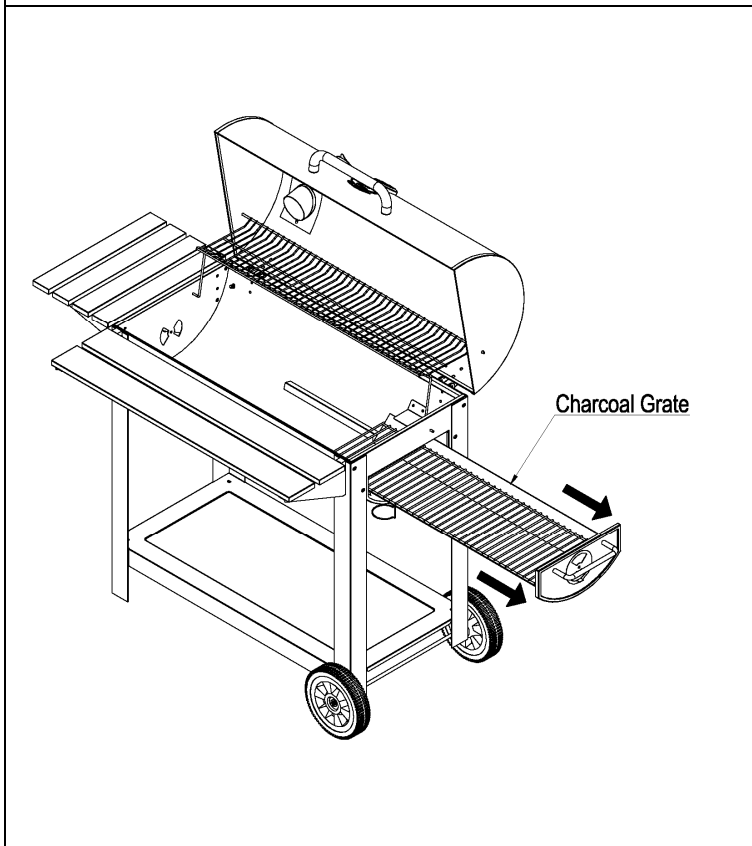

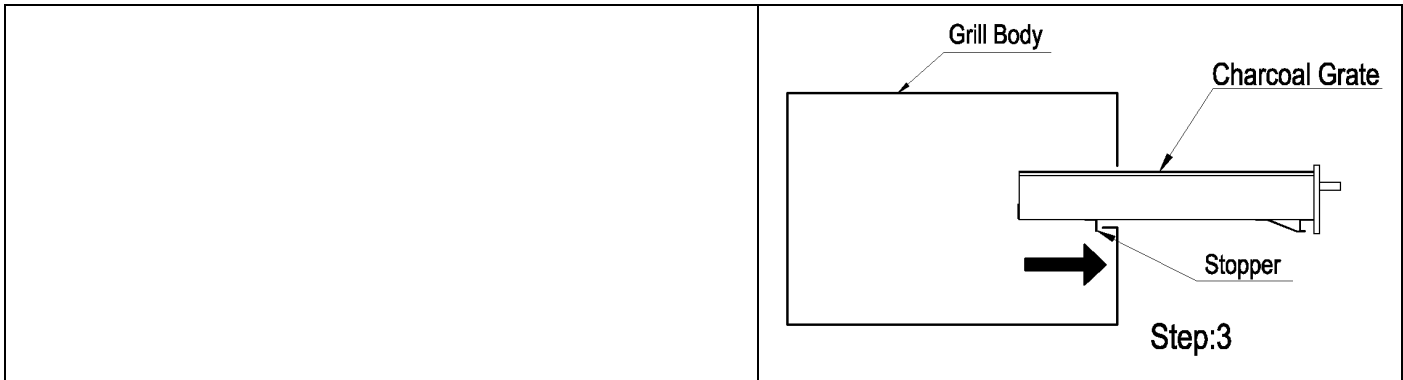

Step 16. REMOVE CHARCOAL GRATE FOR CLEANING : MAKE SURE GRILL IS COOL. (I) Lift up the Charcoal Grate (24). (II) Hold the handle and slide Charcoal Grate out to let back lock at the bottom of Charcoal Grate skip over the latch on the Grill Body. (III) Keep pulling out the Charcoal Grate slowly, and lift the Charcoal Grate up for the stopper to avoid the latch on the side of Grill Body. (IV) Remove the Charcoal Grate and proceed with cleaning. See below illustration Step 1 – Step 3. NOTE: Always close the Air-Vent and wear mittens/gloves before removing the Charcoal Grate

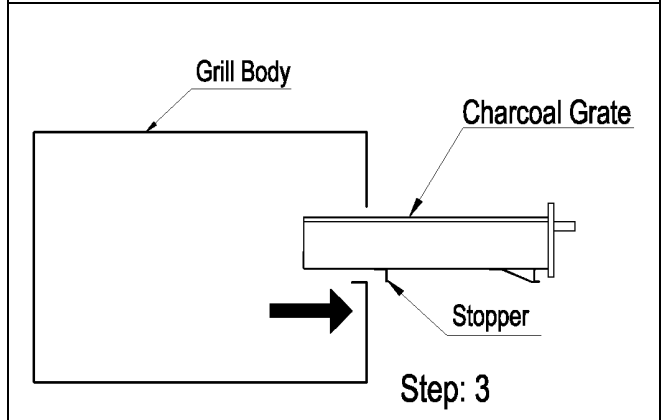
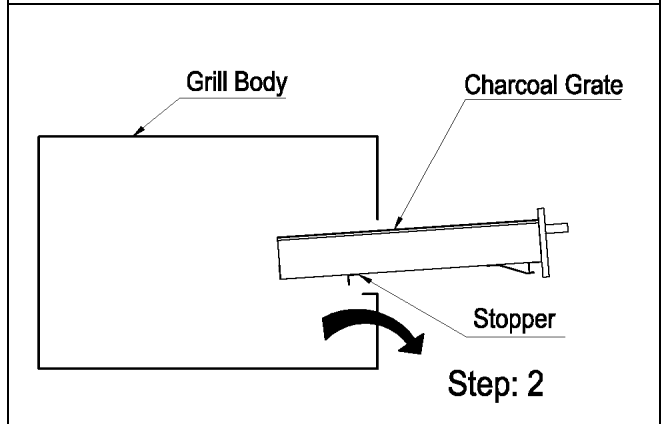
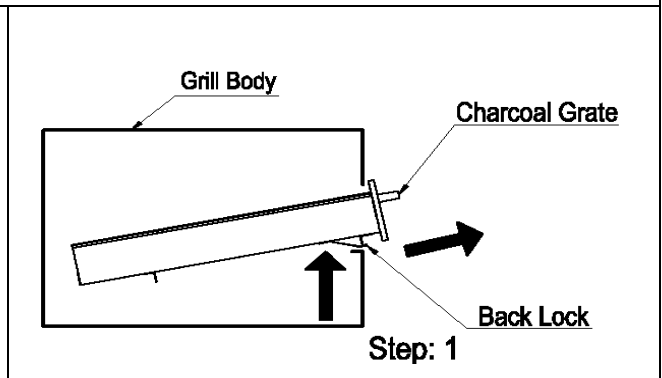
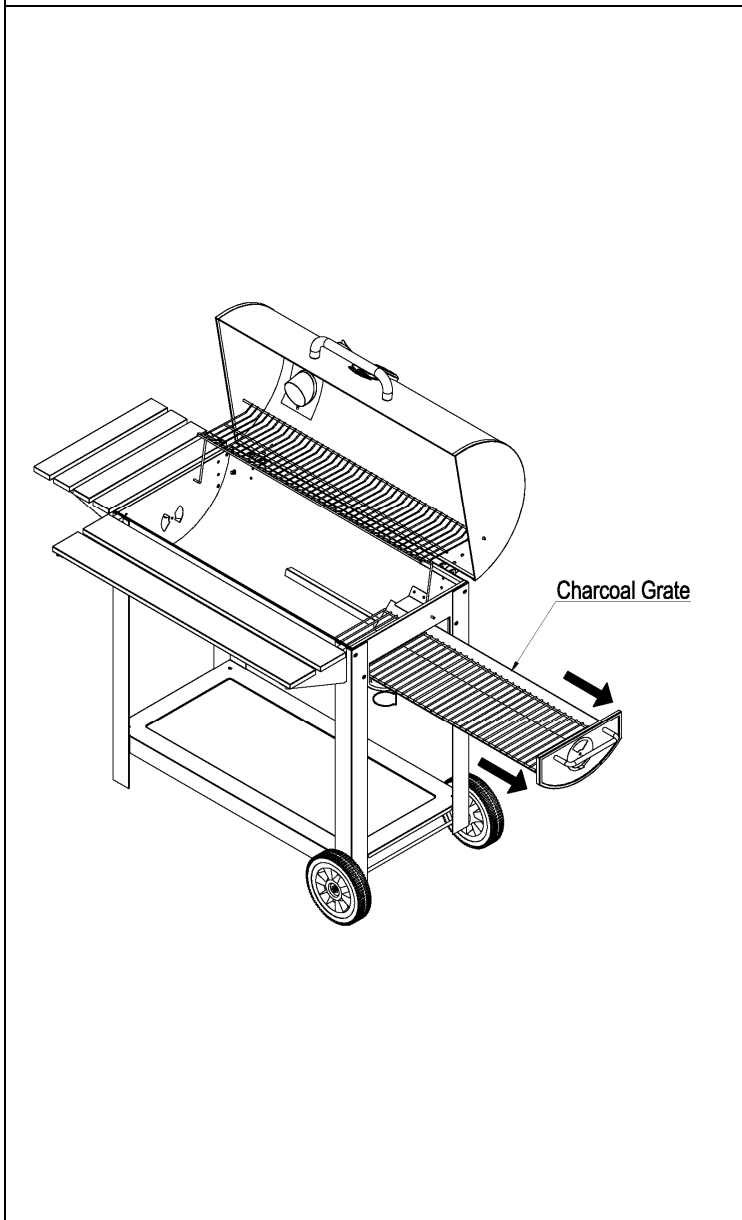

Step 17. Place cooking grid (26) onto the Grill Body (5).

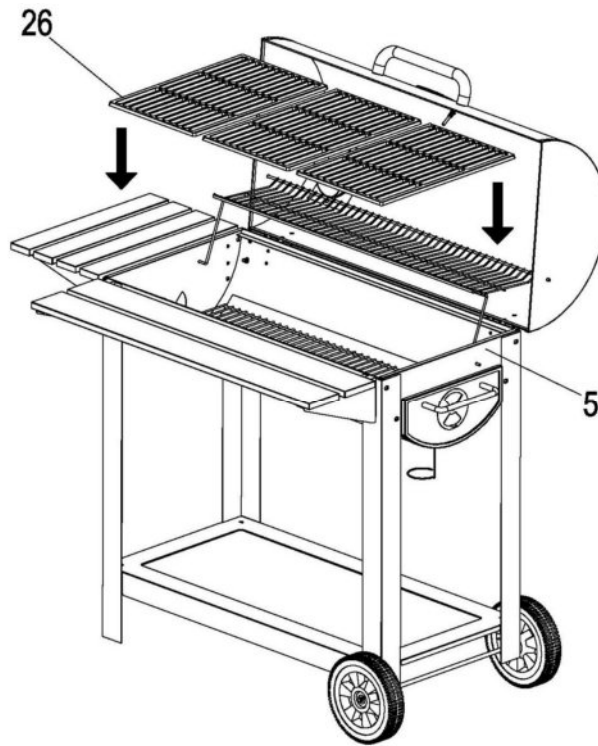

Step 18. Assembly completed!

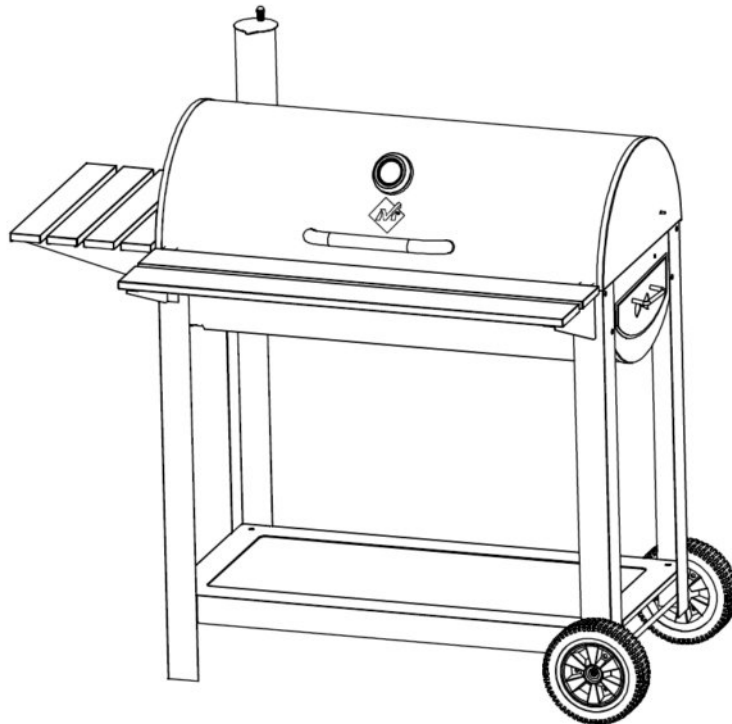



DO NOT use grill without charcoal ash tray in place. DO NOT attempt to remove charcoal ash tray while tray contains hot coals.



Place the grill outdoors on a hard, level, non-combustible surface away from roof overhang or any combustible material. Never use on wooden or other surfaces that could burn. Place the grill away from open windows or doors to prevent smoke from entering your house. In windy weather, place the grill in an outdoor area that is protected from the wind.



Read all safety warnings and instructions carefully before operating your grill.

PREPARATION FOR USE & LIGHTING INSTRUCTIONS

Curing your grill

Prior to your first use of the Grill, follow the instructions below carefully to cure your grill. Curing your grill will minimize damage to the exterior finish as well as get rid of the grill paint odor that can cause unnatural flavors to the first meal prepared on the grill.

IMPORTANT: To protect your grill from excessive rust, the unit must be properly cured and covered at all times when not in use.

Step 1

Lightly coat all interior surfaces of the grill with vegetable oil or vegetable oil spray. Do not coat charcoal grate, grids or charcoal ash tray.

Step 2

Follow the instructions below carefully to build a fire. You may use charcoal and/or wood as fuel in the grill (see "Adding Charcoal/Wood During Cooking" section of this manual).



Never use charcoal that has been pre-treated with lighter fluid. Use only a high grade plain charcoal or charcoal /wood mixture.

If using a Charcoal Chimney Starter, follow all manufacturer's warnings and instructions regarding the use of their product. Start with 5 pounds (2.3kg) of charcoal. This should be enough charcoal to cook with, once the curing process has been completed. When charcoal is burning strong, carefully place hot coals on charcoal grate.

NOTE: To extend the life of your grill, make sure that hot coals and wood do not touch the walls of grill.

IF USING CHARCOAL CHIMNEY STARTER, PROCEED TO STEP 5.



If you choose to use charcoal lighting fluid, **ONLY** use charcoal lighting fluid approved for lighting charcoal. Do not use gasoline, kerosene, alcohol or other flammable material for lighting charcoal. Follow all manufacturer's warnings and instructions regarding the use of their product. Start with 8 to 10 pounds (3.6 to 4.5 kg) of charcoal. This should be enough charcoal to cook with, once the curing process has been completed. Place the charcoal in the center of each charcoal grate.

Step 3

Saturate charcoal with lighting fluid. With lid open, wait 2 to 3 minutes to allow lighting fluid to soak into charcoal. Store lighting fluid a safe distance from the grill.

Step 4

With grill lid open and charcoal grate completely placed inside the grill. Stand back and carefully light charcoal. Allow to burn until covered with a light ash (approximately 20 minutes).

	<h1>WARNING</h1>	
<p>Charcoal lighting fluid must be allowed to completely burn off prior to closing grill lid (approximately 20 minutes). Failure to do this could trap fumes from charcoal lighting fluid in grill and may result in a flash-fire or explosion when lid is opened.</p>		

Step 5

With coals burning strong, close the lid. Allow the temperature to reach 225°F (107°C) on temperature gauge. Maintain this temperature for 2 hours.

Step 6

Increase the temperature to 400°F (205°C) on temperature gauge. This can be achieved by adding more charcoal and/or wood (see "Adding Charcoal/Wood During Cooking" section of this manual). Maintain this temperature for 1 hour then allow unit to cool completely.

NOTE: It is important that the exterior of the grill is not scraped or rubbed during the curing process.

IMPORTANT: to protect your smoker from excessive rust, the unit must be cured periodically and covered at all times when not in use.



OPERATING INSTRUCTIONS

Step 1

Lightly coat all interior surfaces of the grill with vegetable oil or vegetable oil spray. Do not coat charcoal grate, grids or charcoal ash tray.

Step 2

Follow the instructions below carefully to build a fire. You may use charcoal and/or wood as fuel in the Barrel Grill (see "Adding Charcoal/Wood During Cooking" section of this manual).

	<h1>WARNING</h1>	
<p>Never use charcoal that has been pre-treated with lighter fluid. Use only a high grade plain charcoal or charcoal/wood mixture.</p>		

If using a Charcoal Chimney Starter, follow all manufacturer's warnings and instructions regarding the use of their product, start with 5 pounds (2.3 kg) of charcoal. When charcoal is burning strong, carefully place hot coals in center of each charcoal grate.

	<h1>WARNING</h1>	
<p>DO NOT use grill without charcoal ash tray in place. DO NOT attempt to remove charcoal ash tray while tray contains hot coals.</p>		

NOTE: to extend the life of your grill, make sure that hot coals and wood do not touch the walls of grill.

IF USING CHARCOAL CHIMNEY STARTER, PROCEED TO STEP 5.



If you choose to use charcoal lighting fluid, ONLY use charcoal lighting fluid approved for lighting charcoal. Do not use gasoline, kerosene, alcohol or other flammable materials for lighting charcoal. Follow all manufacturer's warnings and instructions regarding the use of their product. Start with 5 pounds (2.3 kg) of charcoal. Place the charcoal in center of each charcoal grate.

Step 3

Saturate charcoal with lighting fluid. With lid open and charcoal grate completely placed inside the grill, wait 2 to 3 minutes to allow lighting fluid to soak into charcoal. Store charcoal lighting fluid a safe distance from the grill.

Step 4

With grill lid open, stand back and carefully light charcoal and allow to burn until covered with a light ash (approximately 20 minutes).

	<h1>WARNING</h1>	
<p>Charcoal lighting fluid must be allowed to completely burn off prior to closing grill lid (approximately 20 minutes). Failure to do this could trap fumes from charcoal lighting fluid in grill and may result in a flash-fire or explosion when lid is opened.</p>		

Step 5

Place cooking grids on grill support lips.

	<h1>WARNING</h1>	
<p>Always wear oven mitts/gloves when adjusting cooking levels to protect your hands from burns.</p>		

Step 6

Place food on cooking grids and close grill lid. Always use a meat thermometer to ensure food is fully cooked before removing from grill.

Step 7

Allow grill to cool completely, and then follow instructions in the "After-Use Safety" and "Proper Care & Maintenance" sections of this manual.

Flavoring Wood

To obtain your favorite smoke flavor, experiment by using chunks, sticks or chips of flavor producing wood such as hickory, pecan, apple, cherry, or mesquite. Most fruit or nut tree wood may be used for smoke flavoring. Do not use resinous wood such as pine as it will produce an unpleasant taste.

Wood chunks or sticks 3" to 4" (7 to 10 cm) long and 1" to 2" (2 to 4 cm) thick work best. Unless the wood is still green, soak the wood in water for 30 minutes or wrap each piece in foil and tear several small holes in the foil to produce more smoke and prevent the wood from burning too quickly. Only a few pieces of wood are required to obtain a good smoke flavor. A recommended amount for the grill is 5 to 6 wood chunks or sticks. Experiment by using more wood for stronger smoke flavor or less wood for milder smoke flavor.

Additional flavoring wood should not have to be added during the cooking process. However, it may be necessary when cooking very large pieces of food. Follow instructions and cautions in the "Adding Charcoal/Wood During Cooking" section of this manual to avoid injury while adding wood.

Regulating Heat

To increase heat, add more wood and/or charcoal. Follow instructions in "Adding Charcoal/Wood During Cooking" section of this manual.

To maintain the temperature, you may need to add more wood and/or charcoal during the cooking cycle.

NOTE: Dry wood burns hotter than charcoal, so you may want to increase the ratio of wood to charcoal to increase the cooking temperature. Hardwood such as oak, hickory, mesquite, fruit and nut wood are an excellent fuel because of their burning rate. When using wood as fuel, make sure the wood is seasoned and dry. **DO NOT** use resinous wood such as pine as it will produce an unpleasant taste.

Adding Charcoal/Wood During Cooking

Additional charcoal and/or wood may be required to maintain or increase cooking temperature.

Step 1

Stand back and carefully open grill lid. Use caution since flames can flare-up when fresh air suddenly comes in contact with fire.

Step 2

Wearing oven mitts/gloves, lift up the cooking grid and place it on a clean and non-combustible surface. **DO NOT** touch the grid by hand.

Step 3



Stand back a safe distance and use long cooking tongs to lightly brush aside ashes on hot coals. Use cooking tongs to add charcoal and/or wood to charcoal grates, being careful not to stir-up ashes and sparks. If necessary, use your Charcoal Chimney Starter to light additional charcoal and/or wood and add to existing fire.



Step 4

When charcoal is burning strong again, wear oven mitts/gloves and carefully the return charcoal grid to grill body. Extinguish any hot ashes, coals or embers which may have fallen from the grill or beneath and around grill.

AFTER-USE SAFETY

	<h1>WARNING</h1>	
<ul style="list-style-type: none">● Always allow grill and all components to cool completely before handling.● Never leave coals and ashes in grill unattended. Make sure coals and ashes are completely extinguished before removing.● Before grill can be left unattended, remaining coals and ashes must be removed from grill. Use caution to protect yourself and property. Place remaining coals and ashes in a non-combustible metal container and completely saturate with water. Allow coals and water to remain in metal container 24 hours prior to disposing.● Extinguished coals and ashes should be placed a safe distance from all structures and combustible materials.● With a garden hose, completely wet surface beneath and around the grill to extinguish any ashes, coals or embers which may have fallen during the cooking or cleaning process.● Cover and store grill in a protected area away from children and pets.		

Proper Care & Maintenance

- Cure your grill periodically throughout the year to protect against excessive rust.
- To protect your grill from excessive rust, the unit must be properly cured and covered at all times when not in use.
- Wash cooking grids and charcoal grates with hot, soapy water, rinse well and dry. Lightly coat grids with vegetable oil or vegetable oil spray.
- Clean inside and outside of grill by wiping off with a damp cloth. Apply a light coat of vegetable oil or vegetable oil spray to the interior surface to prevent rusting. Do not coat charcoal grids or charcoal ash tray.
- If rust appears on the exterior surface of your grill, clean and buff the affected area with steel wool or fine grit emery cloth. Touch-up with a good quality high-temperature resistant paint.
- Never apply paint to the interior surface. Rust spots on the interior surface can be buffed, cleaned, and then lightly coated with vegetable oil or vegetable oil spray to minimize rusting.

How do I season my Cast iron Grids.

1. Before the first use wash grids in hot, soapy water. Use soap this time only. Rinse grids and dry completely using a towel. Towel may become discolored, this is normal.
2. Apply a thin, even coating of melted shortening (Crisco, as an example) to the grids with a soft cloth or paper towel. Apply to both sides of the grids.
3. Heat grill with a small fire to around 350 degrees. Place grids in grill not directly over the coals and close lid. Leave closed for at least one hour. Let grids remain in grill until cool.
4. Place grids in proper position in the grill.

Your cast iron grids should be properly seasoned and ready to use!

Tips & Suggestions:

1. Seasoning is an ongoing process. Periodically reapply the oil to grids with a soft cloth. Especially if you see any rust developing or before long periods of storage.
2. Never put your Cast Iron Grids in the dishwasher or allow to air dry.
3. If rust does appear, remove with a grill brush and repeat the seasoning process.
4. Cleaning of the grids should be done before the cooking begins not after the cooking is over. A little residue left on the Cast Iron grates helps protect them between uses.
5. The more Cast Iron Grids are used the better the non-stick qualities become. This is a great excuse to grill often!

LIMITED WARRANTY

1. Manufacturer warrants this Product to be free from defects in workmanship and materials for a period of Ninety (90) days from the date of purchase, PROVIDED claims are submitted, in writing, with proof of purchase.
2. If any part of this item fails because of a manufacturing defect within the Limited Warranty Period, Manufacturer offers to replace such part(s) provide that such parts have not been improperly repaired, altered, or tampered with or subject to misuse, abuse or exposed to corrosive conditions. This Limited Warranty is, however, subject to certain limitations, exclusions, time limits and exceptions (Hereinafter "Conditions") as listed below. Read these Conditions carefully.
3. This Limited Warranty shall be limited to the replacement or repair of any part(s) which Manufacturer determines, after reasonable examination, to have been defective at the time of manufacturing and manufacturer's obligation(s) shall be limited to replacement, if any, of defective part(s) which shall be shipped at Original Purchaser's expense to Original Purchaser's designated shipping address.
4. This Limited Warranty is given to and covers the **ORIGINAL PURCHASER ONLY** and such coverage terminates Ninety (90) days from the date of purchase.
5. **DAMAGE LIMITATION WARNING:** IN NO EVENT SHALL MANUFACTURER BE LIABLE FOR ANY INCIDENTAL OR CONSEQUENTIAL DAMAGES, INCLUDING (BUT NOT LIMITED TO) LOSS OF USE OF THE PRODUCT, LOSS OF TIME, INCONVENIENCE, EXPENSES FOR TRAVEL, TRANSPORTATION LODGING EXPENSES, LOSS BY DAMAGE TO PERSONAL PROPERTY OR LOSS OF INCOME, PROFITS OR REVENUE.
6. **MANUFACTURER'S OBLIGATION:** Manufacturer's liability shall be limited to the delivery of a good, merchantable Product and, if necessary, the repair or replacement, at manufacturer's option, of any defective part or unit.
7. **TRANSFER LIMITATIONS:** This Limited Warranty is not assignable or transferable. It covers only the original purchaser.
8. **RESERVED RIGHT TO CHANGE:** Manufacturer reserves the right to make changes or improvements to products it produces in the future without imposing on itself any obligations to install the same improvements in the products it has previously manufactured.
9. This Limited Warranty gives the Original Purchaser specific legal rights but there may be other rights which vary by jurisdiction.
10. This warranty does not cover the following items:
 - Chips or scratches on porcelain or painted surfaces
 - Rust or corrosion is not deemed a manufacturing or materials defect
 - Discoloration or loss of paint due to handling during assembly, heat or cleaning products. Paint may require touch up.
 - Stainless steel discoloration or corrosion
 - Consumables such as batteries

IF CUSTOMER SERVICE BECOME NECESSARY:

1. The Original Purchaser is responsible for shipping and handling charges of the returned item(s) and replacement parts, if any.
2. All parts to be replaced will need to be shipped before replacement items will be sent.
3. Follow the Customer Service Representative's instructions exactly. If a return is necessary, it must be packed carefully and shipped prepaid.

Should you encounter any problem or difficulty in obtaining replacement parts

CALL US FIRST.

Do not return product to the store.

WE CAN HELP.

Rankam Metal Products Manufactory Ltd

Please contact Customer Service at customerservice@rankam.com
or at 1-888-837-1380, Mon to Fri, 9:00 a.m. – 5:00 p.m. Pacific Standard Time.