



## Barrel BBQ Grill

Model number: CG2051014-KF

Owner's Manual

Assembly and Operating Instructions



Tools required for assembly (not included): Pliers, Phillips and Flathead Screwdrivers, Adjustable Wrench

**Keep this manual for future reference.**



# WARNING



- Only use this grill on a hard, level, non-combustible, stable surface (concrete, ground, etc.) capable of supporting the weight of the grill. Never use on wooden or other surfaces that could burn.
- When the grill is in use, maintain a clearance of at least 1 m (40") between the hot grill and any combustible materials, such as bushes, trees, wooden decks, wooden fences, buildings, etc. Do not place a hot grill under a roof overhang or in any other enclosed area.
- The maximum weight of charcoal to be used is 1.0kg (2.2 lbs). Too much charcoal may cause the surface coating to peel off.
- **FOR OUTDOOR USE ONLY. DO NOT operate the grill indoors or in an enclosed area** because of carbon monoxide poisoning that can lead to personal injury or death.
- For household use only. Do not use this grill for other than its intended purpose.
- We recommend the use of a charcoal chimney starter to avoid the dangers associated with charcoal lighter fluid. If you choose to use charcoal lighter fluid, only use one approved for lighting charcoal. Carefully read the manufacturer's warnings and instructions on the charcoal lighter fluid and charcoal prior to using them. Store charcoal lighter fluid safely away from the grill.
- When using charcoal lighter fluid, allow the charcoal to burn with the grill lid and doors open until covered with a light ash (approximately 20 minutes). This will allow the charcoal lighter fluid to burn off. Failure to do this could trap fumes from charcoal lighter fluid in the grill and may result in a flash fire or explosion when the lid is opened.
- Do not use gasoline, kerosene or alcohol for lighting charcoal. Use of any of these or similar products could cause an explosion possibly leading to severe bodily injury.
- Never add charcoal lighter fluid to hot or even warm coals, as flashback may occur causing severe burns.
- Never use charcoal that has been pre-treated with light fluid. Use only a high grade plain charcoal or charcoal / wood mixture.
- Place the grill in an area where children and pets cannot come into contact with it. Close supervision is necessary when the grill is in use.
- Do not leave the grill unattended when in use.
- When adding charcoal and / or wood, use extreme caution and follow instructions in the "Adding Charcoal / Wood During Cooking" section of this manual.
- Do not store or use the grill near gasoline or other flammable liquids, gases or where flammable vapours may be present.
- Do not store lighter fluid or other flammable liquids or materials under the grill.
- Use caution when adjusting the charcoal grate height, use oven mitts. The handle will be hot when in use.
- Never raise or lower the charcoal grate when water smoking as hot water may splash on to coals creating a burst of hot steam and coals.

Grill is hot when in use. To avoid burns:

- DO NOT attempt to move the grill.
- Wear protective gloves or oven mitts.
- DO NOT touch any hot grill surfaces.
- DO NOT wear loose clothing or allow hair to come in contact with the grill.



# WARNING



- When grilling, grease from meat may drip into the charcoal and cause a grease fire. If this should happen, close the lid to suffocate the flame. Do not use water to extinguish grease fires.
- Use caution when opening the lid. Keep hands, face and body a safe distance away. Flash flare ups may occur when air comes into contact with fire or hot coals.
- Never place more than 2.3 kg (5 lbs) on the side tables.
- Do not allow charcoal and/or wood to rest on the walls of the grill. Doing so will greatly reduce the life of the metal and finish of your grill.
- Use caution during assembly and while operating your grill to avoid scrapes or cuts from sharp edges of metal parts. Use caution when reaching into or under the grill.
- When opening the lid, be sure it is fully opened and secure to prevent it from closing unexpectedly.
- In windy weather, place the grill in an outdoor area that is protected from the wind.
- Close the lid to suffocate flame.
- Never leave coals and ashes in the grill unattended. Before the grill can be left unattended, remaining coals and ashes must be removed from the grill. Use caution to protect yourself and property. Carefully place the remaining coals and ashes in a non-combustible metal container and saturate completely with water. Allow the coals and water to remain in the metal container 24 hours prior to disposing.
- Extinguished coals and ashes should be placed a safe distance from all structures and combustible materials.
- With a garden hose, completely wet the surface beneath and around the grill to extinguish any ashes, coals or embers which may have fallen during the cooking or cleaning process.
- After each use, clean the grill thoroughly and apply a light coat of vegetable oil to prevent rusting. Cover the grill to protect it from excessive rusting.
- Use caution when lifting or moving the grill to prevent strains and back injuries.
- We advise that a fire extinguisher be on hand. Refer to your local authority to determine proper size and type of fire extinguisher.
- Store the grill out of reach of children and in a dry location when not in use.
- Do not attempt to services the grill other than by normal maintenance, as explained in the “After-Use Safety” and “Proper Care & Maintenance” sections of this manual.
- Properly dispose of all packaging material.
- Use caution and common sense when operating your grill.
- Failure to adhere to safety warnings and guidelines in this manual could result in bodily injury or property damage.
- To installer or person assembling this appliance: Leave this manual with this appliance for future reference.

**Wash your hands after handling this product**



# CALIFORNIA PROPOSITION 65



 **WARNING:** This product can expose you to chemicals including soot, which is known to the State of California to cause cancer, and carbon monoxide, which is known to the State of California to cause birth defects or other reproductive harm. For more information go to [www.P65Warnings.ca.gov](http://www.P65Warnings.ca.gov).

# ASSEMBLY INSTRUCTIONS

## THANK YOU FOR PURCHASING THIS GRILL

Read all safety warnings & assembly instructions carefully before assembling or operating your grill.

For missing parts, please call customer service at [customerservice@rankam.com](mailto:customerservice@rankam.com) or at 1-888-837-1380, Mon to Fri, 8:00 a.m. – 5:00 p.m. Pacific Standard Time.

(Proof of purchase will be required.)

Inspect contents of the box to ensure all parts are included and undamaged.

We recommend two people for assembly of this grill.





The following tools are required for assembly and are not included:

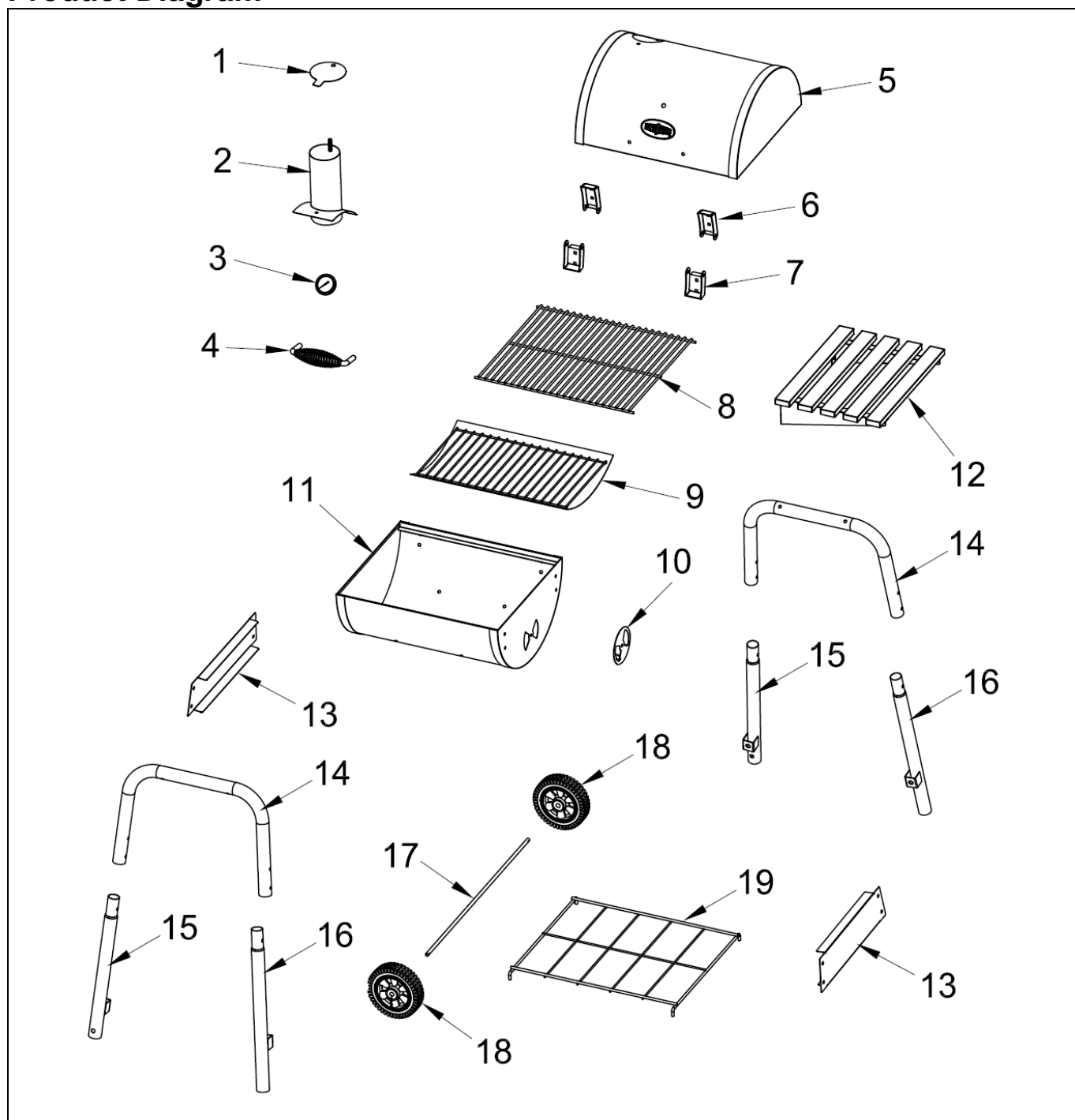

- Pliers
- Philips & Flathead Screwdrivers
- Adjustable Wrench

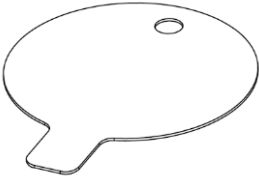
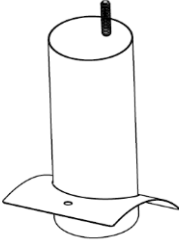
## Product Diagram

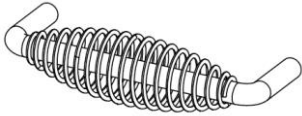
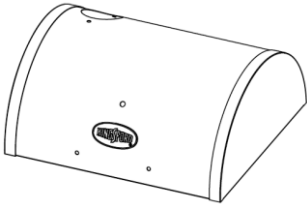
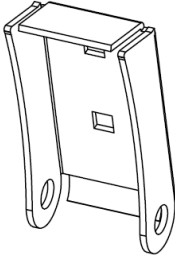
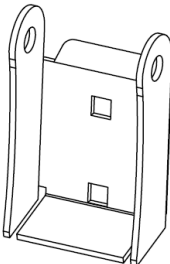
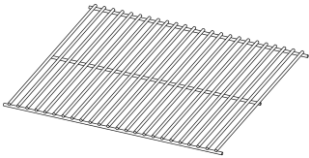
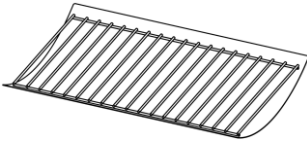

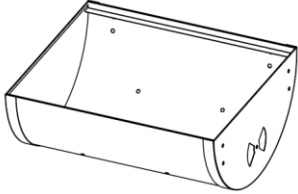
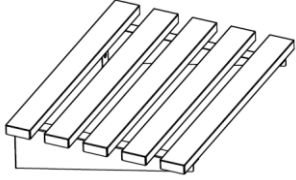
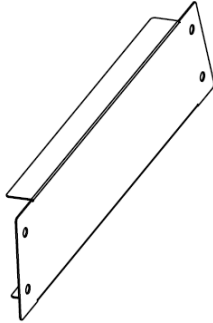
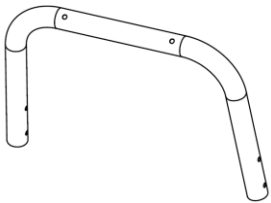
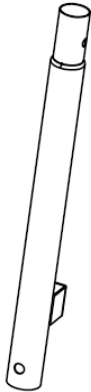
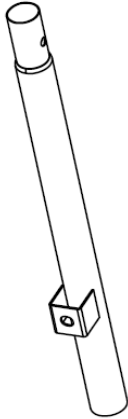

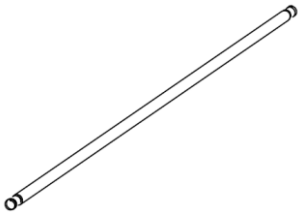

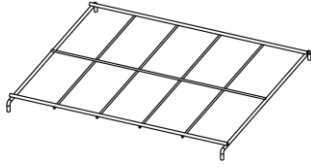

# Component List

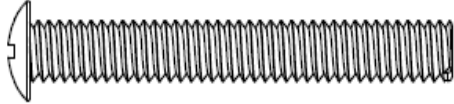
<p><b>1. Chimney Cover</b></p>  <p><b>Qty: 1pc</b></p>	<p><b>2. Chimney</b></p>  <p><b>Qty: 1pc</b></p>	<p><b>3. Temperature Gauge</b></p>  <p><b>Qty: 1pc</b></p>	<p><b>4. Handle</b></p>  <p><b>Qty: 1pc</b></p>
<p><b>5. Lid</b></p>  <p><b>Qty: 1pc</b></p>	<p><b>6. Lid Hinge</b></p>  <p><b>Qty: 2pcs</b></p>	<p><b>7. Body Hinge</b></p>  <p><b>Qty: 2pcs</b></p>	<p><b>8. Cooking Grate</b></p>  <p><b>Qty: 1pc</b></p>
<p><b>9. Charcoal Rack</b></p>  <p><b>Qty: 1pc</b></p>	<p><b>10. Air Vent</b></p>  <p><b>Qty: 1pc</b></p>	<p><b>11. Grill Body</b></p>  <p><b>Qty: 1pc</b></p>	<p><b>12. Side Table</b></p>  <p><b>Qty: 1pc</b></p>
<p><b>13. Stabilizing Plate</b></p>  <p><b>Qty: 2pcs</b></p>	<p><b>14. Leg Brace</b></p>  <p><b>Qty: 2pcs</b></p>	<p><b>15. Front Leg</b></p>  <p><b>Qty: 2pcs</b></p>	<p><b>16. Rear Leg</b></p>  <p><b>Qty: 2pcs</b></p>

<p><b>17. Axle</b></p>  <p><b>Qty: 1pc</b></p>	<p><b>18. Wheel</b></p>  <p><b>Qty: 2pcs</b></p>	<p><b>19. Wire Rack</b></p>  <p><b>Qty: 1pc</b></p>	
---	---	---	--

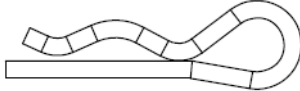
## Hardware List

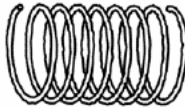
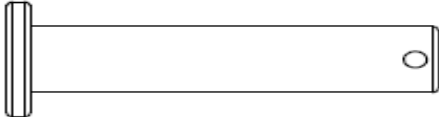
Item No.	Item name	Diagram	Qty
A	M6x40mm Bolt		12
B	M6x30mm Bolt		8
C	M6x12mm Bolt		9
D	M8 Cup Nut		1
E	Cotter Pin		4
F	M6 Flange Nut		27
G	Spring		1
H	Hinge Pin		2

## **STOP! DO NOT RETURN TO RETAILER.**

For assembly assistance, missing or damaged parts, **please call customer service 888-837-1380.**

### **Assembly Procedures**

**Symbol:** The following symbols will be shown in each procedure for indication of tightening the bolt and nut if necessary.

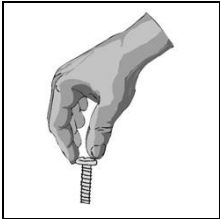

**Hand Tighten only at this time**

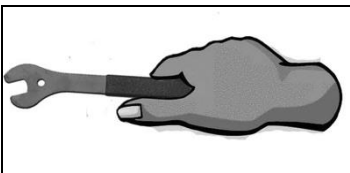

**Tighten with tools at this time**

**Some steps may require the assistance of a friend.**



# **WARNING**



- Please wear gloves while assembling the grill.

## Assembly Procedures

**Step 1.** Insert front legs (15) into leg braces (14).  
Insert rear legs (16) into leg braces (14).

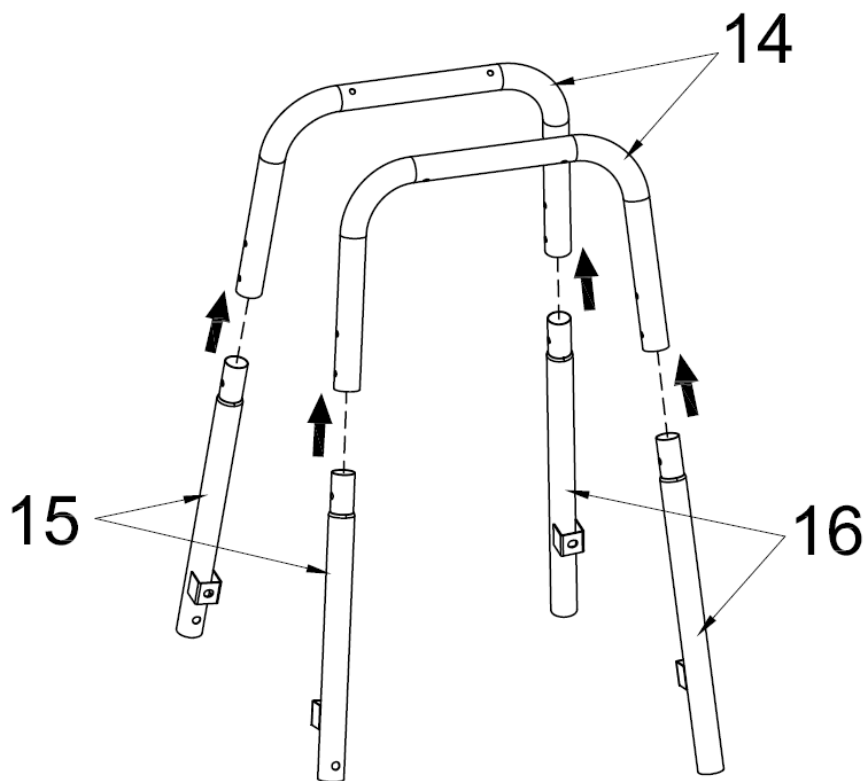

**Step 2.** Insert corners of the wire rack (19) into the brackets on the legs.  
Rotate the assembled legs toward the center of the wire rack (19).

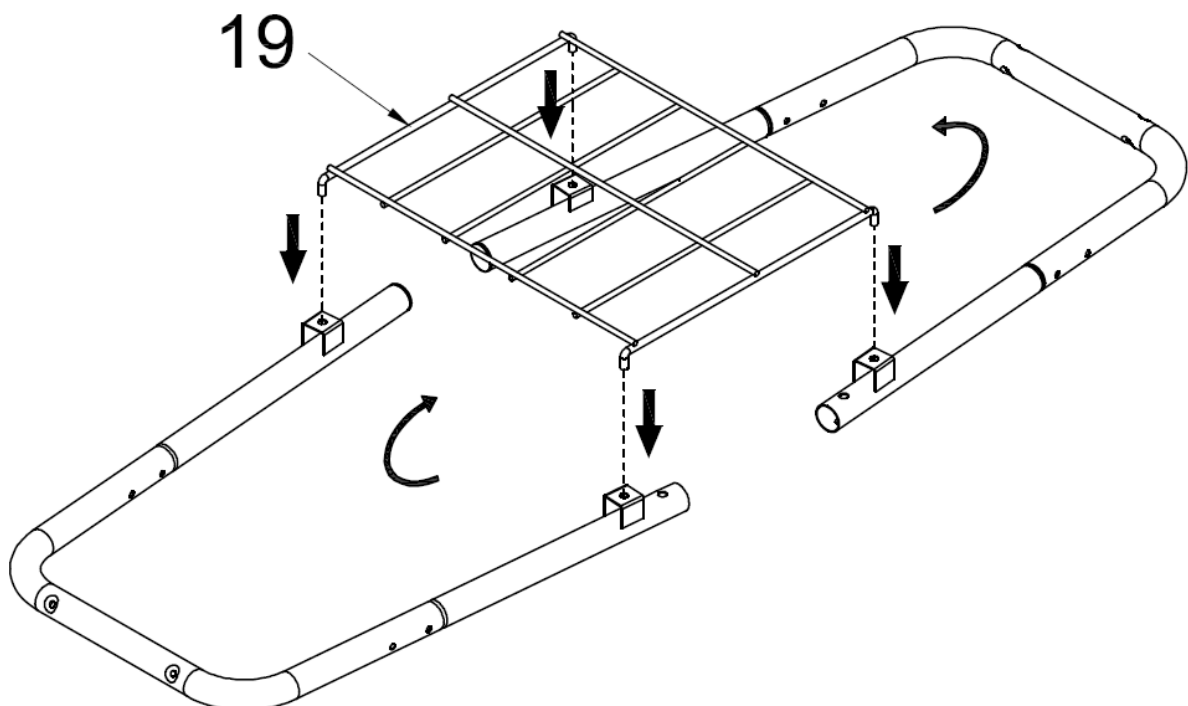



**Step 3.** Attach stabilizing plates (13) on both ends of assembled legs using 8 screws (A) and 8 flange nuts (F).

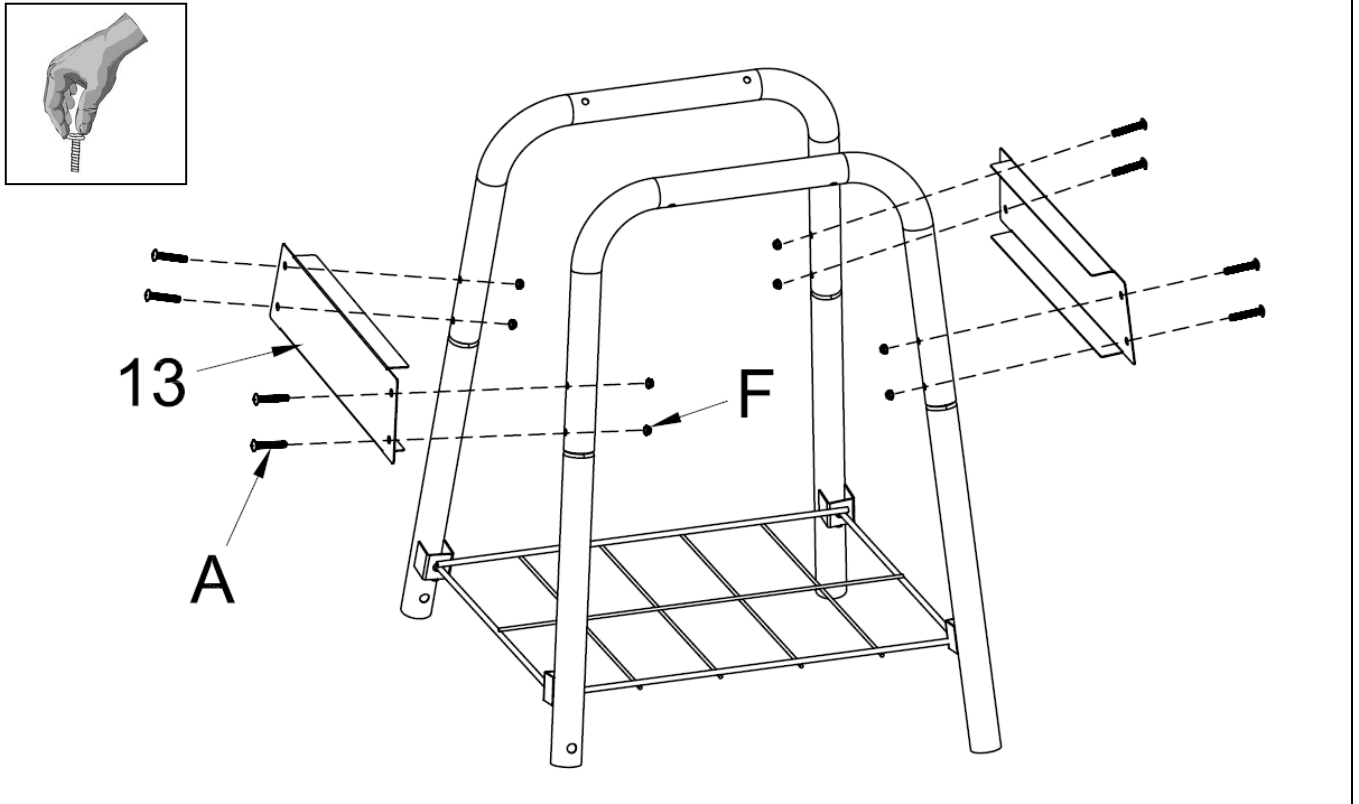

**Step 4.** Thread the axle (17) through the holes at the end of front legs (15). The axle will extend from the outside of both legs. Put a wheel (18) on both ends of the axle. Insert the cotter pin (E) in the end of each axle to hold wheels in place.

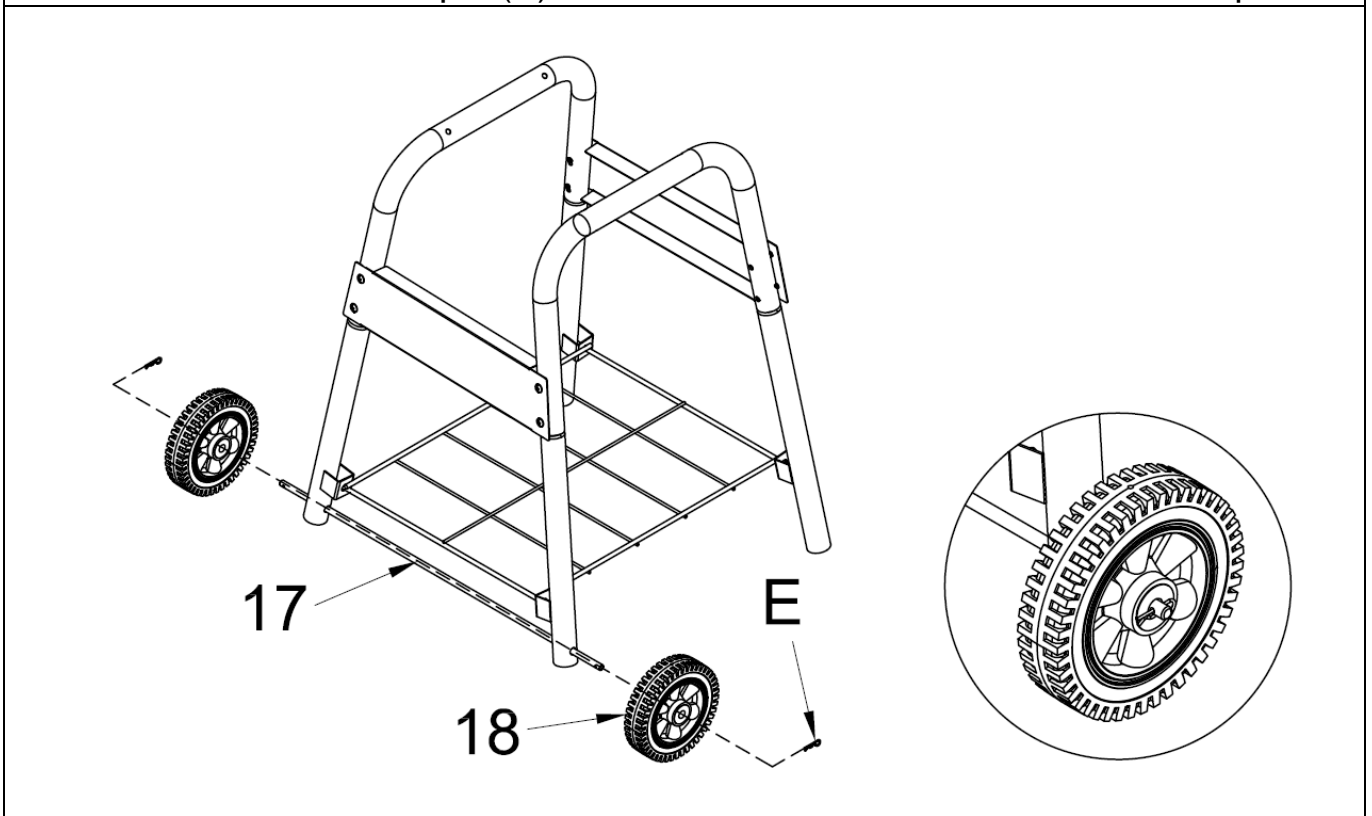

**Step 5.** Set grill body (11) on the assembled leg frame and secure with 4 screws (A) and 4 flange nuts (F).

Note: Holes for shelf bracket on grill body (11) need to face the opposite side as assembled wheels. Tighten all hardware.

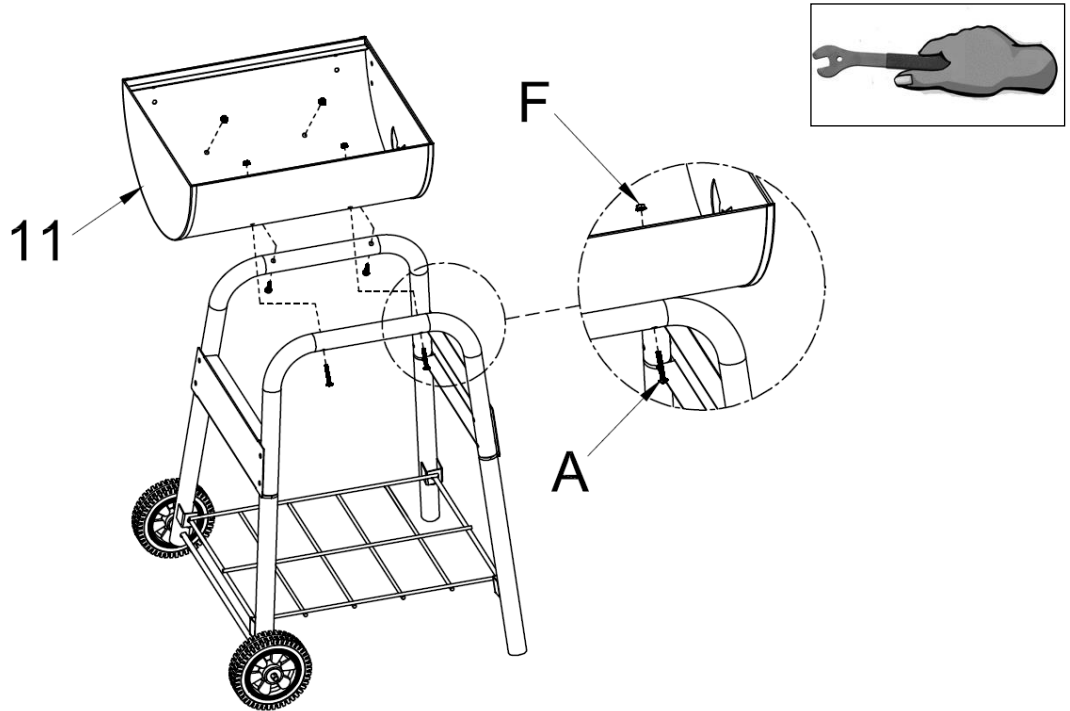

**Step 6.** Attach air vent (10) to the grill body with 1 screw (C) and 1 flange nuts (F). The toggle must face and point outward from grill.

Attach each body hinge (7) to the back of the grill body with 2 screws (B) and 2 flange nuts (F).

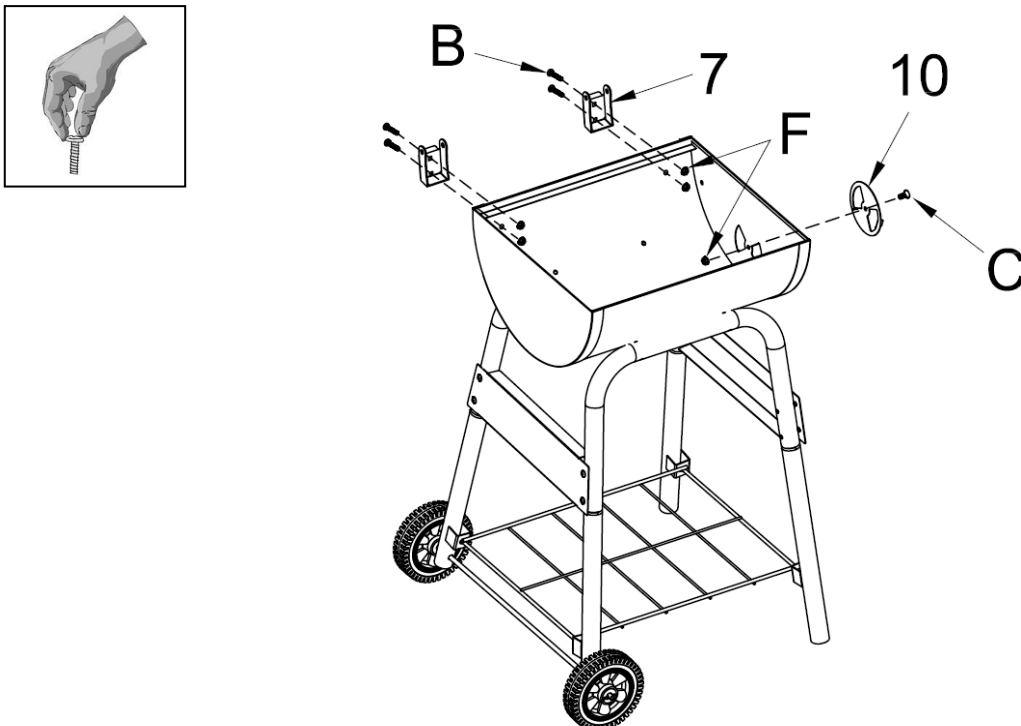

**Step 7.** Align the screw holes of the bracket of the side table (12) with the two pair of holes located on the side of the body. Use a pair of screws (C) and a pair of flange nuts (F) at each bracket to secure the side table (12) to the grill body.

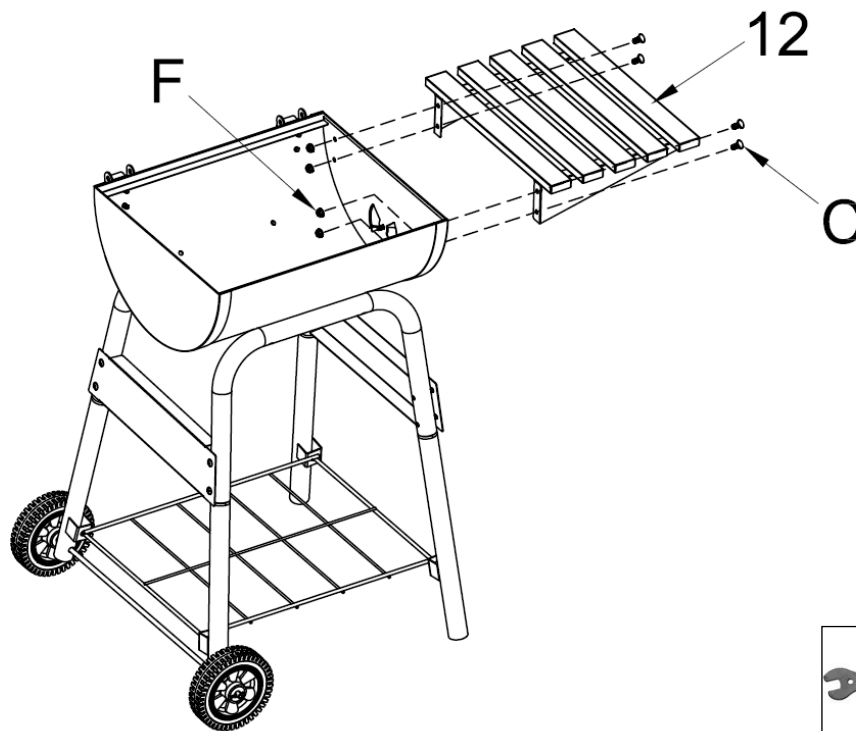

**Step 8.** Attach the chimney (2) to the Lid (5) with a pair of screws (C) and a pair of flange nuts (F).

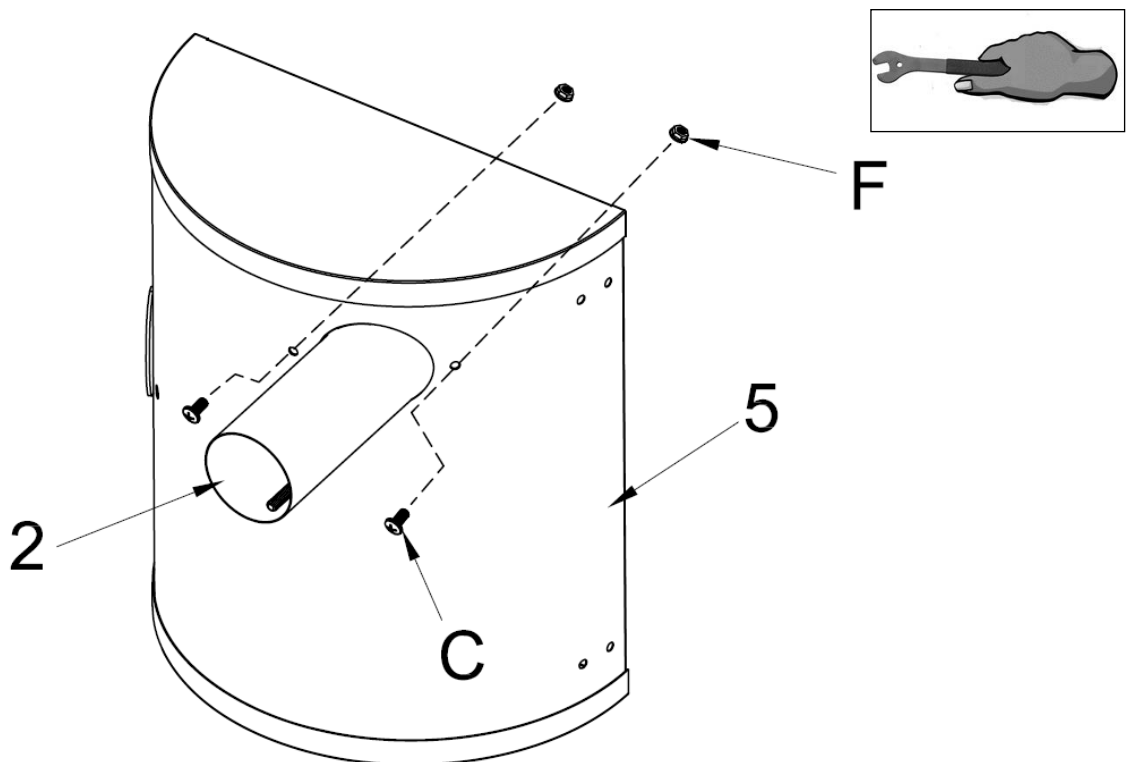

**Step 9.** Place chimney cover (1) on chimney (2) and secure with 1 spring (G) and 1 cap nut (D).

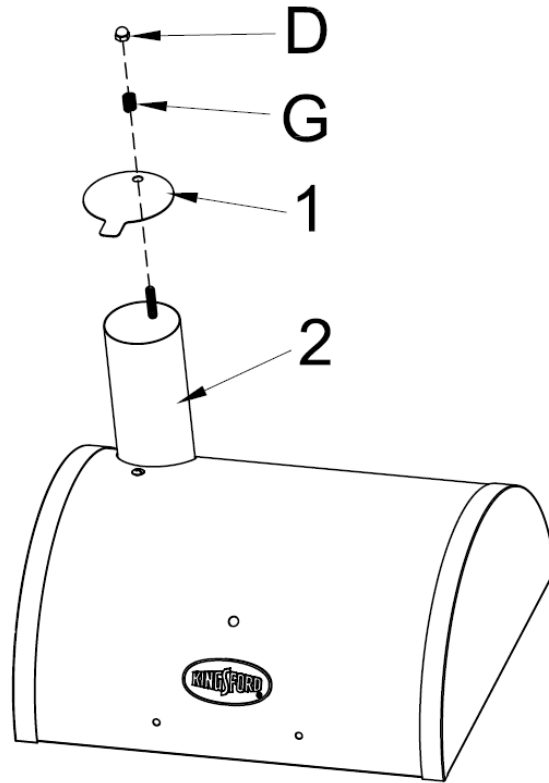

**Step 10.** Remove the nut from the temperature gauge (3), attach the gauge to the front of the lid, replace nut and tighten. Attach the Lid Handle (4) to the Lid with a pair of screws (C).

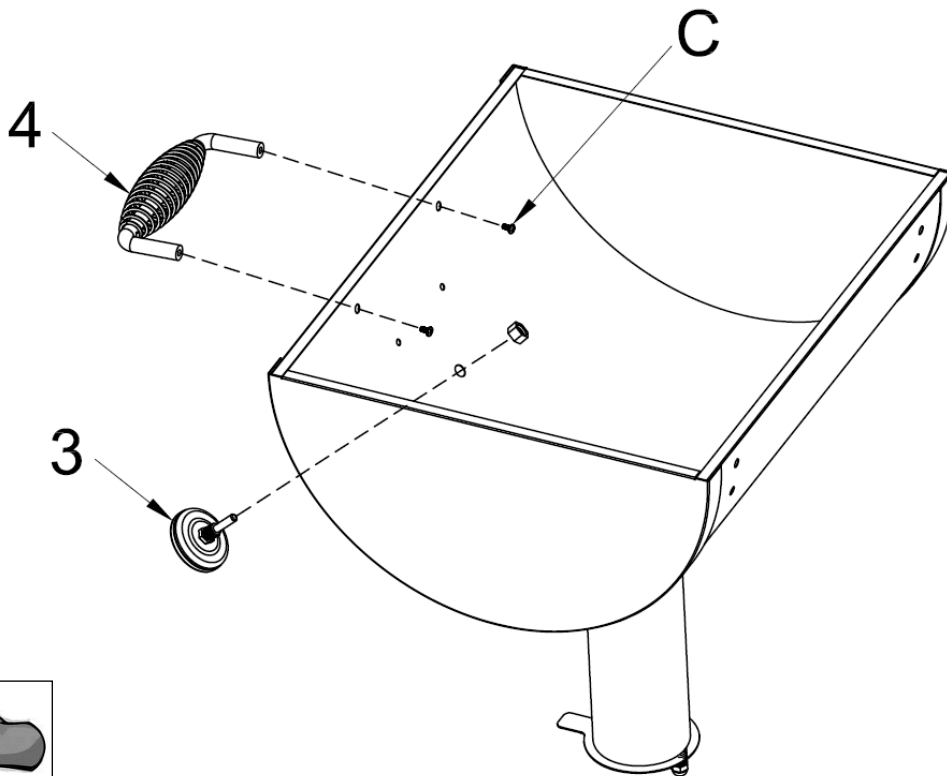

**Step 11.** Attach the lid hinge (6) to the lid with 2 screws (B) and 2 flange nuts (F) for each hinge, on the outside of lid.

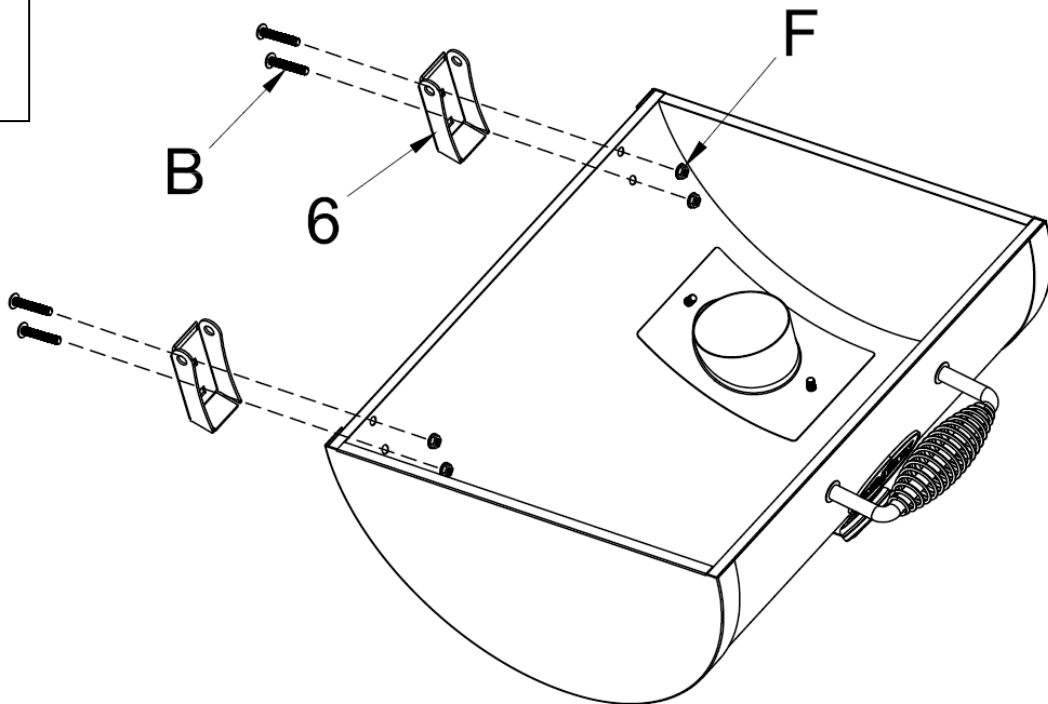
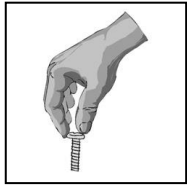

**Step 12:** Place the lid assembly on grill body assembly. Align holes in the lid hinges with holes in body hinges and insert hinge pins (H) to connect hinges. Insert a cotter pin (E) into the holes on each hinge pin.

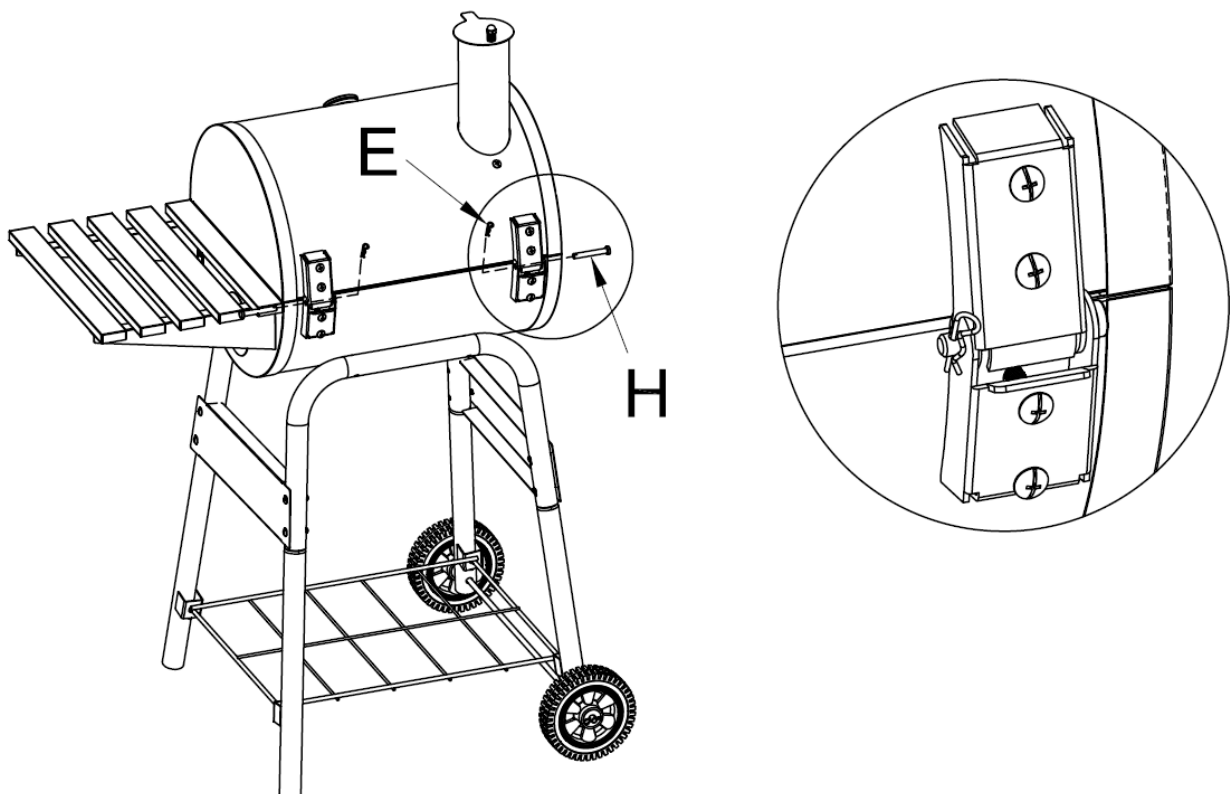

**Step 13:** Place the charcoal rack (9) inside the grill body, followed by the cooking grate (8).

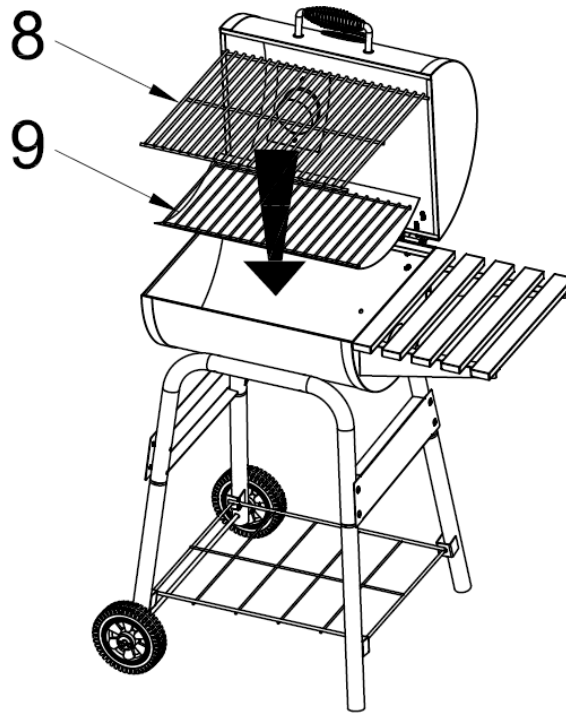

**Step 14:** If you find the lid and the grill body do not align properly, try the following steps to rectify the problem.

1. Loosen the bolts and nuts on the lid hinge (6) and the body hinge (7). Remove the hinge pins (H).
2. Re-align the lid and the grill body. Then Insert the hinge pins (H).
3. Tighten the bolts and nuts on the lid hinge and the body hinge.

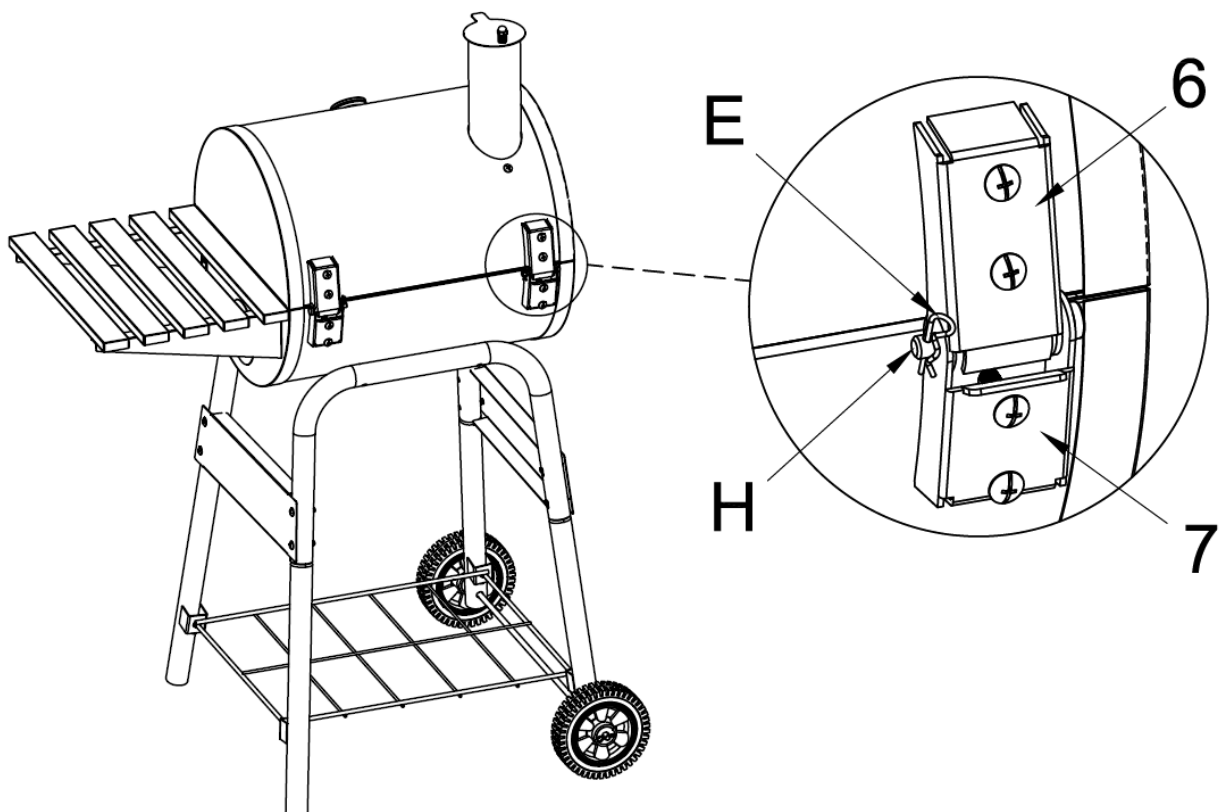

**Step 15.** Tighten all hardware.

Your unit is fully assembled! Make sure to read and follow the Instruction Manual before using this appliance.



## WARNING



Place the grill outdoors on a hard, level, non-combustible surface away from roof overhang or any combustible material. Never use on wooden or other surfaces that could burn. Place the grill away from open windows or doors to prevent smoke from entering your house. In windy weather, place the grill in an outdoor area that is protected from the wind.



## WARNING



Read all safety warnings and instructions carefully before operating your grill.

# PREPARATION FOR USE & LIGHTING INSTRUCTIONS

## Curing your grill

Prior to your first use of the Grill, follow the instructions below carefully to cure your grill. Curing your grill will minimize damage to the exterior finish as well as get rid of the grill paint odor that can impart unnatural flavours to the first meal prepared on the grill.

**IMPORTANT:** To protect your grill from excessive rust, the unit must be properly cured and covered at all times when not in use.

### Step 1

Lightly coat all interior surfaces of the grill with vegetable oil or vegetable oil spray. Do not coat charcoal grates or racks.

### Step 2

Follow the instructions below carefully to build a fire. You may use charcoal and/or wood as fuel in the grill (see "Adding Charcoal/Wood During Cooking" section of this manual).

If using a Charcoal Chimney Starter, follow all manufacturer's warnings and instructions regarding the use of their product. Start with 1.0 kg (2.2 lbs) of charcoal.

### Instruction for reference only:

1. Begin with three full sheets of newspaper.
2. Take 2 sheets of newspaper and roll each into a tube shape and then give them a little twist to form each of them into a straight rope like shape. Be careful to not twist too tight.
3. Turn the charcoal chimney starter over and place both pieces of rolled and twisted newspaper along the inside bottom of the charcoal chimney starter to form a complete circle. Leave a hole in the middle of the charcoal chimney starter with no paper in it.
4. Crumple up the third sheet of newspaper into a ball. Be careful to not crumple too tight. Sprinkle about 1 table spoon of cooking oil on the ball of newspaper. You can also use a few sprits of cooking oil from a spray can.  
Don't use too much oil. Place the ball of cooking-oiled newspaper in the center of the charcoal chimney starter.
5. Flip the chimney over and add charcoal. Take care so that the newspaper does not fall out.
6. Use a match or long lighter to light the paper.
7. Stand back and watch the charcoal chimney starter do its stuff.
8. After charcoal has turned an ash gray color, carefully pour the charcoal onto your grill's fire grate.

**NOTE:** To extend the life of your grill, make sure that hot coals and wood do not touch the walls of grill.

### IF USING CHARCOAL CHIMNEY STARTER, PROCEED TO STEP 5.

If you choose to use charcoal lighter fluid, ONLY use a product approved for lighting charcoal. Do not use gasoline, kerosene, alcohol or other flammable material for lighting charcoal. Follow all manufacturer's warnings and instructions regarding the use of their product. Start with 1.0kg (2.2lbs) of charcoal. Place the charcoal in the center of each charcoal grate.

### Step 3

Saturate charcoal with lighter fluid. With lid open, wait 2 to 3 minutes to allow lighter fluid to soak into charcoal.

**Store lighter fluid a safe distance from the grill.**

### Step 4

With grill lid open and charcoal grate completely placed inside the grill, stand back and carefully light charcoal. Allow to burn until covered with a light ash (approximately 20 minutes).





## WARNING



Charcoal lighter fluid must be allowed to completely burn off prior to closing grill lid (approximately 20 minutes). Failure to do this could trap fumes from charcoal lighter fluid in grill and may result in a flash-fire or explosion when lid is opened.

### Step 5

With coals burning strong, close the lid. Allow the temperature to reach 107°C (225°F) on the temperature gauge. Maintain this temperature for 2 hours.

### Step 6

Increase the temperature to 205°C (400°F) on the temperature gauge. This can be achieved by adding more charcoal and/or wood (see “Adding Charcoal/Wood During Cooking” section of this manual). Maintain this temperature for 1 hour then allow unit to cool completely.

**NOTE: It is important that the exterior of the grill is not scraped or rubbed during the curing process.**

**IMPORTANT: to protect your grill from excessive rust, the unit must be cured periodically and covered at all times when not in use.**

## OPERATING INSTRUCTIONS

### Step 1

Lightly coat all interior surfaces of the grill with vegetable oil or vegetable oil spray. Do not coat charcoal grate or racks.

### Step 2

Follow the instructions below carefully to build a fire. You may use charcoal and/or wood as fuel in the grill (see “Adding Charcoal/Wood During Cooking” section of this manual).

If using a Charcoal Chimney Starter, follow all manufacturer’s warnings and instructions regarding the use of their product. Start with 1.0 kg (2.2 lbs) of charcoal. When charcoal is burning strong, carefully place hot coals in center of each charcoal grate.

#### Instruction for reference only:

1. Begin with three full sheets of newspaper.
2. Take 2 sheets of newspaper and roll each into a tube shape and then give them a little twist to form each of them into a straight rope like shape. Be careful to not twist too tight.
3. Turn the charcoal chimney starter over and place both pieces of rolled and twisted newspaper along the inside bottom of the charcoal chimney starter to form a complete circle. Leave a hole in the middle of the charcoal chimney starter with no paper in it.
4. Crumple up the third sheet of newspaper into a ball. Be careful to not crumple too tight. Sprinkle about 1 table spoon of cooking oil on the ball of newspaper. You can also use a few sprits of cooking oil from a spray can. Don’t use too much oil. Place the ball of cooking-oiled newspaper in the centre of the charcoal chimney starter.
5. Flip the chimney over and add charcoal. Take care so that the newspaper does not fall out.
6. Use a match or long lighter to light the paper.
7. Stand back and watch the charcoal chimney starter do its stuff.
8. After charcoal has turned an ash gray color, carefully pour the charcoal onto your grill’s fire grate.

NOTE: to extend the life of your grill, make sure that hot coals and wood do not touch the walls of grill.

#### IF USING LIGHTER CHARCOAL CHIMNEY STARTER, PROCEED TO STEP 5.

If you choose to use charcoal lighting fluid, ONLY use a product approved for lighting charcoal. Do not use gasoline, kerosene, alcohol or other flammable materials for lighting charcoal. Follow all manufacturer’s warnings and instructions regarding the use of their product. Start with 1.0 kg (2.2 lbs) of

charcoal. Place the charcoal in center of each charcoal grate.



**Step 3**

Saturate charcoal with lighting fluid. With lid open and charcoal grate completely placed inside the grill, wait 2 to 3 minutes to allow lighter fluid to soak into charcoal.

**Store charcoal lighter fluid a safe distance from the grill.**

**Step 4**

With the grill lid open, stand back and carefully light charcoal and allow to burn until covered with a light ash (approximately 20 minutes).

	<b>WARNING</b>	
<p>Charcoal lighting fluid must be allowed to completely burn off prior to closing grill lid (approximately 20 minutes). Failure to do this could trap fumes from charcoal lighting fluid in grill and may result in a flash-fire or explosion when lid is opened.</p>		

**Step 5**

Place cooking grates on the grill support lips.

	<b>WARNING</b>	
<p>Always wear oven mitts/gloves when adjusting cooking levels to protect your hands from burns.</p>		

**Step 6**

Place food on cooking grates and close grill lid. Always use a meat thermometer to ensure food is fully cooked before removing from the grill.

**Step 7**

Allow the grill to cool completely, and then follow instructions in the “After-Use Safety” and “Proper Care & Maintenance” sections of this manual.

## Flavoring Wood

To obtain your favorite smoke flavor, experiment by using chunks, sticks or chips of flavor producing wood such as hickory, pecan, apple, cherry, or mesquite. Most fruit or nut tree wood may be used for smoke flavoring. Do not use resinous wood such as pine as it will produce an unpleasant taste.

Wood chunks or sticks 7 to 10 cm (3" to 4") long and 2 to 4 cm (1" to 2") thick work best. Unless the wood is still green, soak the wood in water for 30 minutes or wrap each piece in foil and tear several small holes in the foil to produce more smoke and prevent the wood from burning too quickly. Only a few pieces of wood are required to obtain a good smoke flavor. A recommended amount for the grill is 5 to 6 wood chunks or sticks. Experiment by using more wood for stronger smoke flavor or less wood for milder smoke flavor.

Additional flavoring wood should not have to be added during the cooking process. However, it may be necessary when cooking very large pieces of food. Follow instructions and cautions in the "Adding Charcoal/Wood During Cooking" section of this manual to avoid injury while adding wood.

## Regulating Heat

To increase heat, add more wood and/or charcoal. Follow instructions in "Adding Charcoal/Wood During Cooking" section of this manual.

To maintain the temperature, you may need to add more wood and/or charcoal during the cooking cycle.

**NOTE:** Dry wood burns hotter than charcoal, so you may want to increase the ratio of wood to charcoal to increase the cooking temperature. Hardwood such as oak, hickory, mesquite, fruit and nut wood are an excellent fuel because of their burning rate. When using wood as fuel, make sure the wood is seasoned and dry. **DO NOT** use resinous wood such as pine as it will produce an unpleasant taste.

The amount of food determines the amount of lump charcoal or charcoal briquette to be used. Add charcoal gradually and observe the grilling temperature via the temperature gauge. Adding too much charcoal into the grill at a time may raise the burning temperature rapidly and cause damages to the grill.

## Adding Charcoal/Wood During Cooking

Additional charcoal and/or wood may be required to maintain or increase cooking temperature.

### Step 1

Stand back and carefully open the grill lid. Use caution since flames can flare-up when fresh air suddenly comes in contact with fire.

### Step 2

Wearing oven mitts/gloves to lift up the cooking grates and place them on a clean and non-combustible surface. **DO NOT** touch the grates by hand.

### Step 3

Stand back a safe distance and use long cooking tongs to lightly brush aside ashes on hot coals. Use cooking tongs to add charcoal and/or wood to charcoal grates, being careful not to stir-up ashes and sparks. If necessary, use your Charcoal Chimney Starter to light additional charcoal and/or wood and add to existing fire.



## WARNING



Never add charcoal lighting fluid to hot or even warm coals as flashback may occur causing severe burns.

#### Step 4

When charcoal is burning strong again, wear oven mitts/gloves and carefully return the charcoal grates to grill body. Extinguish any hot ashes, coals or embers which may have fallen from the grill or beneath and around the grill.

## AFTER-USE SAFETY



### WARNING



- Always allow grill and all components to cool completely before handling.
- Never leave coals and ashes in grill unattended. Make sure coals and ashes are completely extinguished before removing.
- Before grill can be left unattended, remaining coals and ashes must be removed from grill. Use caution to protect yourself and property. Place remaining coals and ashes in a non-combustible metal container and completely saturate with water. Allow coals and water to remain in metal container 24 hours prior to disposing.
- Extinguished coals and ashes should be placed a safe distance from all structures and combustible materials.
- With a garden hose, completely wet surface beneath and around the grill to extinguish any ashes, coals or embers which may have fallen during the cooking or cleaning process.
- Cover and store grill in a protected area away from children and pets.

## Proper Care & Maintenance

- Cure your grill periodically throughout the year to protect against excessive rust.
- To protect your grill from excessive rust, the unit must be properly cured and covered at all times when not in use.
- Wash cooking grates and charcoal grates with hot, soapy water, rinse well and dry. Lightly coat grates with vegetable oil or vegetable oil spray.
- Clean inside and outside of grill by wiping off with a damp cloth. Apply a light coat of vegetable oil or vegetable oil spray to the interior surface to prevent rusting. Do not coat charcoal grates or racks.
- If rust appears on the exterior surface of your grill, clean and buff the affected area with steel wool or fine grit emery cloth. Touch-up with a good quality high-temperature resistant paint.
- Never apply paint to the interior surface. Rust spots on the interior surface can be buffed, cleaned, and then lightly coated with vegetable oil or vegetable oil spray to minimize rusting.

## **LIMITED WARRANTY**

1. Manufacturer warrants this Product to be free from defects in workmanship and materials for a period of 1 year from the date of purchase, PROVIDED claims are submitted, in writing, with proof of purchase.
2. If any part of this item fails because of a manufacturing defect within the Limited Warranty Period, Manufacturer offers to replace such part(s) provide that such parts have not been improperly repaired, altered, or tampered with or subject to misuse, abuse or exposed to corrosive conditions. This Limited Warranty is, however, subject to certain limitations, exclusions, time limits and exceptions (Hereinafter "Conditions") as listed below. Read these Conditions carefully.
3. This Limited Warranty shall be limited to the replacement or repair of any part(s) which Manufacturer determines, after reasonable examination, to have been defective at the time of manufacturing and manufacturer's obligation(s) shall be limited to replacement, if any, of defective part(s) which shall be shipped at Original Purchaser's expense to Original Purchaser's designated shipping address.
4. This Limited Warranty is given to and covers the **ORIGINAL PURCHASER ONLY** and such coverage terminates 1 year from the date of purchase.
5. **DAMAGE LIMITATION WARNING:** IN NO EVENT SHALL MANUFACTURER BE LIABLE FOR ANY INCIDENTAL OR CONSEQUENTIAL DAMAGES, INCLUDING (BUT NOT LIMITED TO) LOSS OF USE OF THE PRODUCT, LOSS OF TIME, LOSS OF FOOD, INCONVENIENCE, EXPENSES FOR TRAVEL, TRANSPORTATION LODGING EXPENSES, LOSS BY DAMAGE TO PERSONAL PROPERTY OR LOSS OF INCOME, PROFITS OR REVENUE.
6. **MANUFACTURER'S OBLIGATION:** Manufacturer's liability shall be limited to the delivery of a good, merchantable Product and, if necessary, the repair or replacement, at manufacturer's option, of any defective part or unit.
7. **TRANSFER LIMITATIONS:** This Limited Warranty is not assignable or transferable. It covers only the original purchaser.
8. **RESERVED RIGHT TO CHANGE:** Manufacturer reserves the right to make changes or improvements to products it produces in the future without imposing on itself any obligations to install the same improvements in the products it has previously manufactured.
9. This Limited Warranty gives the Original Purchaser specific legal rights but there may be other rights which vary by jurisdiction.
10. This warranty does not cover the following items:
  - Chips or scratches on porcelain or painted surfaces.
  - Rust or corrosion is not deemed a manufacturing or materials defect.
  - Discoloration or loss of paint due to handling during assembly, heat or cleaning products. Paint may require touch up.
  - Stainless steel discoloration or corrosion.
  - Consumables such as batteries.

### **IF CUSTOMER SERVICE BECOME NECESSARY:**

1. The Original Purchaser is responsible for shipping and handling charges of the returned item(s) and replacement parts, if any.
2. All parts to be replaced will need to be shipped before replacement items will be sent.
3. Follow the Customer Service Representative's instructions exactly. If a return is necessary, it must be packed carefully and shipped prepaid.

Should you encounter any problem,

or

Obtain replacement parts

**CALL US FIRST.**

Do not return product to the store.

**WE CAN HELP.**

**Rankam (China) Manufacturing Company Limited**

18/F., New Lee Wah Centre, 88 Tokwawan Road, Kowloon, HongKong

Please contact Customer Service at:

[customerservice@rankam.com](mailto:customerservice@rankam.com)

or at

1-888-837-1380,

Hours of Operation: Mon to Fri, 8:00 a.m. – 5:00 p.m. Pacific Standard Time.

Made in China

**KINGSFORD® AND THE KINGSFORD® LOGO ARE REGISTERED TRADEMARKS OF THE KINGSFORD® PRODUCTS COMPANY, LLC AND ARE USED UNDER LICENCE BY RANKAM (CHINA) MANUFACTURING COMPANY LIMITED ALL RIGHTS RESERVED.**