

This Owner's Manual is provided and hosted by [Appliance Factory Parts](#).



MASTERBUILT 20030811 Owner's Manual

[Shop genuine replacement parts for MASTERBUILT
20030811](#)



[Find Your MASTERBUILT Grill Parts - Select From 589 Models](#)

----- Manual continues below -----



**ASSEMBLY, CARE & USE MANUAL
WARNING & SAFETY INFORMATION**

PROPANE GRILL



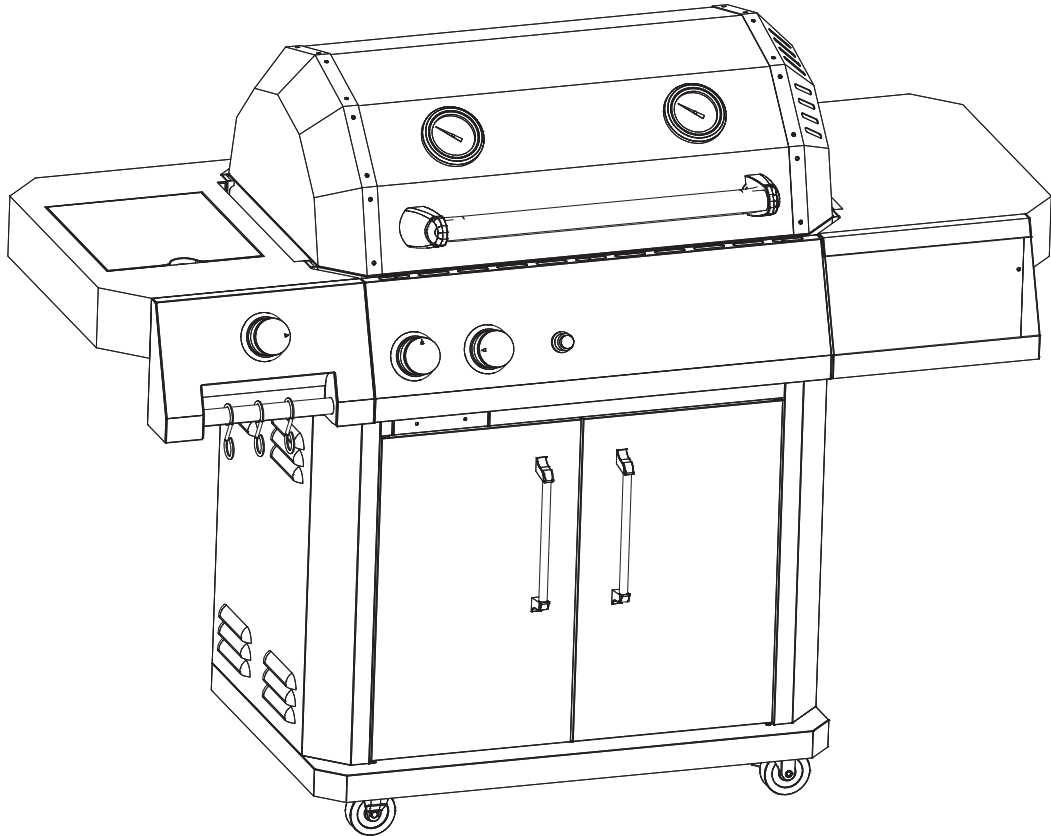

MODELS 20030711, 20030811, 20030911





THIS PRODUCT IS FOR OUTDOOR USE ONLY



Manual Code: 9803110003 051012-18SS

Tools needed for assembly: Adjustable Wrench, Phillips Head Screwdriver

 CARBON MONOXIDE HAZARD 	 WARNING 
<p>Burning wood chips gives off carbon monoxide, which has no odor and can cause death.</p> <p>DO NOT burn wood chips inside homes, vehicles, tents, garages or any enclosed areas.</p> <p>Use only outdoors where it is well ventilated.</p>	<p>This manual contains important information necessary for the proper assembly and safe use of the appliance.</p> <p>Read and follow all warnings and instructions before assembling and using the appliance.</p> <p>Follow all warnings and instructions when using the appliance.</p> <p>Keep this manual for future reference.</p>
<p>Failure to follow these warnings and instructions properly could result in fire or explosion, which could cause property damage, personal injury, or death.</p>	

 DANGER 	 DANGER 
<p>If you smell gas:</p> <ol style="list-style-type: none"> 1. Shut off gas to the appliance. 2. Extinguish any open flame. 3. Open/remove door. 4. If odor continues, keep away from the appliance and immediately call your Fire Department. 	<ol style="list-style-type: none"> 1. Never operate this appliance unattended. 2. Never operate this appliance within 10 feet (3m) of any structure, combustible material or other gas cylinder. 3. Never operate this appliance within 25 feet (7.5m) of flammable liquids. 4. If fire should occur keep away from appliance and immediately call your fire department. Do not attempt to extinguish an oil/grease fire with water.
<p>FAILURE TO FOLLOW THESE INSTRUCTIONS COULD RESULT IN FIRE, EXPLOSION OR BURN HAZARD, WHICH COULD CAUSE PROPERTY DAMAGE, PERSONAL INJURY OR DEATH.</p>	

 **GENERAL WARNINGS AND SAFETY INFORMATION** 

- Unit is for outdoor use only.
- Never use inside enclosed areas such as patios, garages, buildings or tents.
- Never use inside recreational vehicles or on boats.
- Never operate unit under overhead construction such as roof coverings, carports, awnings, or overhangs.
- Never use unit as a heater.
- Maintain a minimum distance of 10ft (3m) from overhead construction, walls, rails or other structures.
- Keep a minimum 10ft (3m) clearance of all combustible materials such as wood, dry plants, grass, brush, paper, or canvas.
- Keep appliance clear and free from combustible materials such as gasoline and other flammable vapors and liquids.
- Use unit on a level, non-combustible, stable surface such as dirt, concrete, brick or rock.
- Keep children and pets away from unit at all times. Do NOT allow children to use unit.
- Unit has an open flame. Keep hands, hair, and face away from burner flame. Do NOT lean over burner when lighting. Loose hair and clothing may catch fire.
- Allow unit to cool below 115°F (46°C) before moving or storing.
- Avoid bumping or impacting unit.
- This unit is HOT while in use and during cooling process. Wear protective gloves/mitts.
- Use of alcohol, prescription or non-prescription drugs may impair user's ability to properly assemble or safely operate unit.
- Never use glass, plastic or ceramic cookware in unit.
- Do NOT allow anyone to conduct activities around unit during or following its use until it has cooled.
- Accessory attachments not supplied by Masterbuilt Manufacturing, Inc. are not recommended.
- Never use unit for anything other than its intended use. This unit is NOT for commercial use.
- Use in accordance with local, state and federal fire codes.
- This appliance shall not be used on or under any apartment or condominium balcony or deck.



GENERAL WARNINGS AND SAFETY INFORMATION



- Use 20LB (9kgs) gas cylinder that has protective collar (cylinder not included with unit).
- Installation of unit must conform with local codes or in the absence of local codes, with National Fuel Gas Code, ANSIZ223.1/NFPA 54, Storage and Handling of Liquefied Petroleum Gasses, ANSI/NFPA 58 or CSA B149.1, Natural Gas Installation Code; Propane Storage and Handling, CSA B149.2; or the Standard for Recreational Vehicles, ANSI A119.2/NFPA 1192; and Recreational Vehicle Code, CSA Z240 RV Series as applicable.
- LP gas cylinder being used must be constructed and marked in accordance with specifications for LP gas cylinders of the US Department of Transportation (DOT) or the Standard for Cylinders, Spheres and Tubes for the Transportation for Dangerous Goods, CAN/CSA-B339.
- Always perform soapy water test (see “Soapy Water Test Instructions” in this manual) **EVERY TIME** you use unit.
- Before each use check all nuts, screws and bolts to make sure they are tight and secure.
- Before each use inspect gas hose for signs of damage.
- Always disconnect gas cylinder from unit when not in use.
- Never attach/disconnect gas cylinder, move or alter gas fittings when unit is in operation.
- Never use gas cylinder if there is evidence of dents, gouges, bulges, fire damage, erosion, leakage, excessive rust, or other forms of visible external damage. This may be hazardous and cylinder should be taken to a liquid propane supplier to be checked.
- Regulator and hose assembly supplied with unit **MUST** be used. For replacement parts, if needed, contact Masterbuilt Customer Service at 1-800-489-1581.
- When lighting burner remove all grill parts to prevent explosion from gas build up.
- If ignition does not take place within five seconds using ignitor button, turn gas control valve to off position and wait five minutes and repeat lighting procedures.
- Keep fuel supply hose away from unit while in operation.
- Keep fuel supply hose away from any heated surface.
- Do **NOT** obstruct flow of combustion and ventilation. Keep ventilation openings of cylinder enclosure free and clear of debris.
- When use is complete, always turn regulator control valve **OFF** first, then gas cylinder valve **OFF**.
- Gas **MUST** be turned off at the supply cylinder when not in use.
- Do **NOT** store spare LP gas cylinder under or near unit. Gas cylinder safety relief valve may overheat allowing gas to release causing fire which may cause death or serious injury.
- Never fill cylinder over 80% full or cylinder may release gas causing fire which may cause death or serious injury.
- If you smell, hear or see gas escaping, immediately get away from gas cylinder and call the Fire Department. Fire may cause death or serious injury.
- Place a dust cap on cylinder valve outlet whenever cylinder is not in use. Only install dust cap provided with cylinder. Other caps or plugs may cause leaks.
- Cylinder **MUST** be stored outdoors, out of children’s reach and must **NOT** be stored in a building, garage, or any other enclosed area.
- This appliance is not for frying turkeys.

SOAPY WATER TEST WARNINGS & PROCEDURES

WARNINGS

- Soapy Water Test **MUST** be performed each time gas cylinder is connected to burner/hose or each time it is used.
- Soapy Water Test **MUST** be performed outdoors in well ventilated area.
- When performing Soapy Water Test keep grill away from open flames, sparks or lit cigarettes.
- Grill is designed to work with propane gas only. Only use gas cylinders marked propane with this unit. This product will **NOT** operate with natural gas.
- Never use an open flame to test for gas leaks.

PREPARATION:

- Remove any cookware from grill.
- Make sure regulator and gas cylinder valve to OFF position.
- Prepare soapy water solution: (1) part dish washing liquid (or more if desired), (3) parts water.
- Apply soapy water solution to gas cylinder valve, regulator and hose length up to burner.

Apply solution to gas cylinder valve

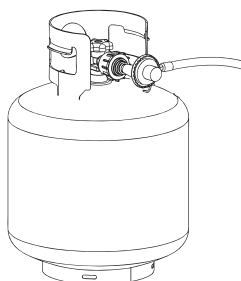

Apply solution to hose regulator and the full length of the hose

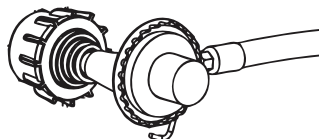

Apply solution underneath control panel where burner and hose are connected

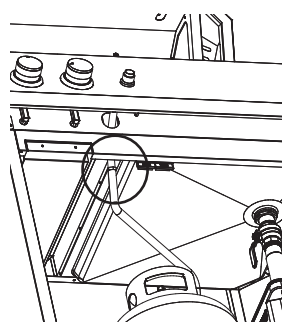

Failed test will present bubbles as shown below.

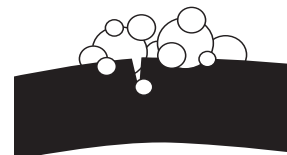

TESTING GAS VALVE:

- Turn gas cylinder valve ON and watch for bubbles. **DO NOT LEAVE GAS ON MORE THAN 12 SECONDS.** If bubbles appear, stop, turn gas cylinder OFF and retighten fitting. Repeat test.

TESTING REGULATOR AND HOSE:

- **AFTER** gas cylinder valve has passed Soapy Water Test, turn gas cylinder valve ON, open regulator control valve one full turn and check for bubbles at valve location, along full length of hose and at burner connection. **DO NOT LEAVE GAS ON MORE THAN 12 SECONDS.** If bubbles appear, stop, turn regulator valve OFF, turn gas cylinder OFF and retighten the connection that is leaking gas. If hose is source of leak, **STOP**, do not use unit. Hose must be replaced.
- When test is complete, and there are no leaks, wait minimum of 5 minutes for gas fumes to diminish before lighting cooker.

DURING ANY PORTION OF SOAPY WATER TEST IF BUBBLES CONTINUE TO APPEAR, STOP, DO NOT USE UNIT. CONTACT LOCAL PROPANE DEALER OR MASTERBUILT CUSTOMER SERVICE @ 1-800-489-1581.

Note: Use 20LB (9kgs) gas cylinder that has a protective collar with this unit. Cylinder **NOT** included with this unit.



WARNING



PERFORM “SOAPY WATER TEST” BEFORE EACH USE. SEE “SOAPY WATER TEST” SECTION IN MANUAL. EXTINGUISH ALL OPEN FLAMES BEFORE CONNECTING REGULATOR TO GAS CYLINDER. TURN GAS OFF AFTER EACH USE.

REGULATOR, BURNER AND GAS VALVE CONNECTION & OPERATION

CLOCKWISE COUNTER
CLOCKWISE

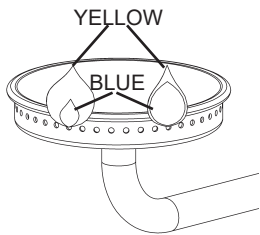
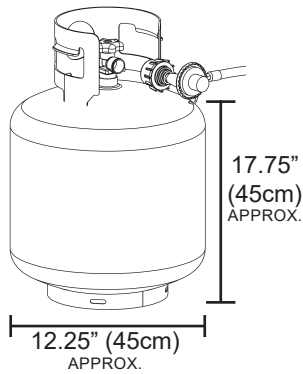

- Inspect hose before each use. If there are signs of wear, cuts, or leaks, replace unit. **DO NOT USE.**
- Inspect burner before each use. Check burner and burner ventura tube for insects and insect nests. A clogged tube can lead to a fire beneath appliance.
- Connect hose regulator to LP Gas Cylinder
 1. Make sure gas cylinder valve is closed. Turn knob clockwise until it stops.
 2. Make sure control knob on grill is in the “OFF” position.
 3. Remove protective cap from gas cylinder and coupling nut if applicable.
 4. Center and insert regulator nipple into valve outlet on gas cylinder as shown in figure on the left. Turn regulator coupling nut clockwise until it stops. **DO NOT OVER TIGHTEN.**
- Perform Soapy Water Test.
- To use turn gas cylinder ON, turn burner control knob counter-clockwise and push ignitor button to light.
- If ignition does not take place within five seconds, turn gas control valve to off position and wait five minutes and repeat lighting procedures. If ignition still does not occur, see match light directions below.
- After use turn burner control knob OFF, then turn gas cylinder OFF.
- Burner control knob adjusts burner flame. Turn control knob clockwise **SLOWLY** to increase flame. Turn control knob counter-clockwise to decrease flame and shut flame off.
- Visually check burner flame. A **CORRECT FLAME** should be blue with a small amount of yellow at the tip. An **INCORRECT FLAME** is excessively yellow and irregular. If an incorrect flame occurs, turn burner control knob to “OFF” position, turn off regulator and propane tank. Allow unit to cool and then clean burner. Let burner completely dry before re-lighting.



DO NOT RETURN TO RETAILER For Assembly Assistance, Missing or Damaged Parts
 Call: MASTERBUILT Customer Service at 1-800-489-1581.
 Please have Model Number and Serial Number available when calling.
 These numbers are located on silver label on back of unit.

PARTS LIST

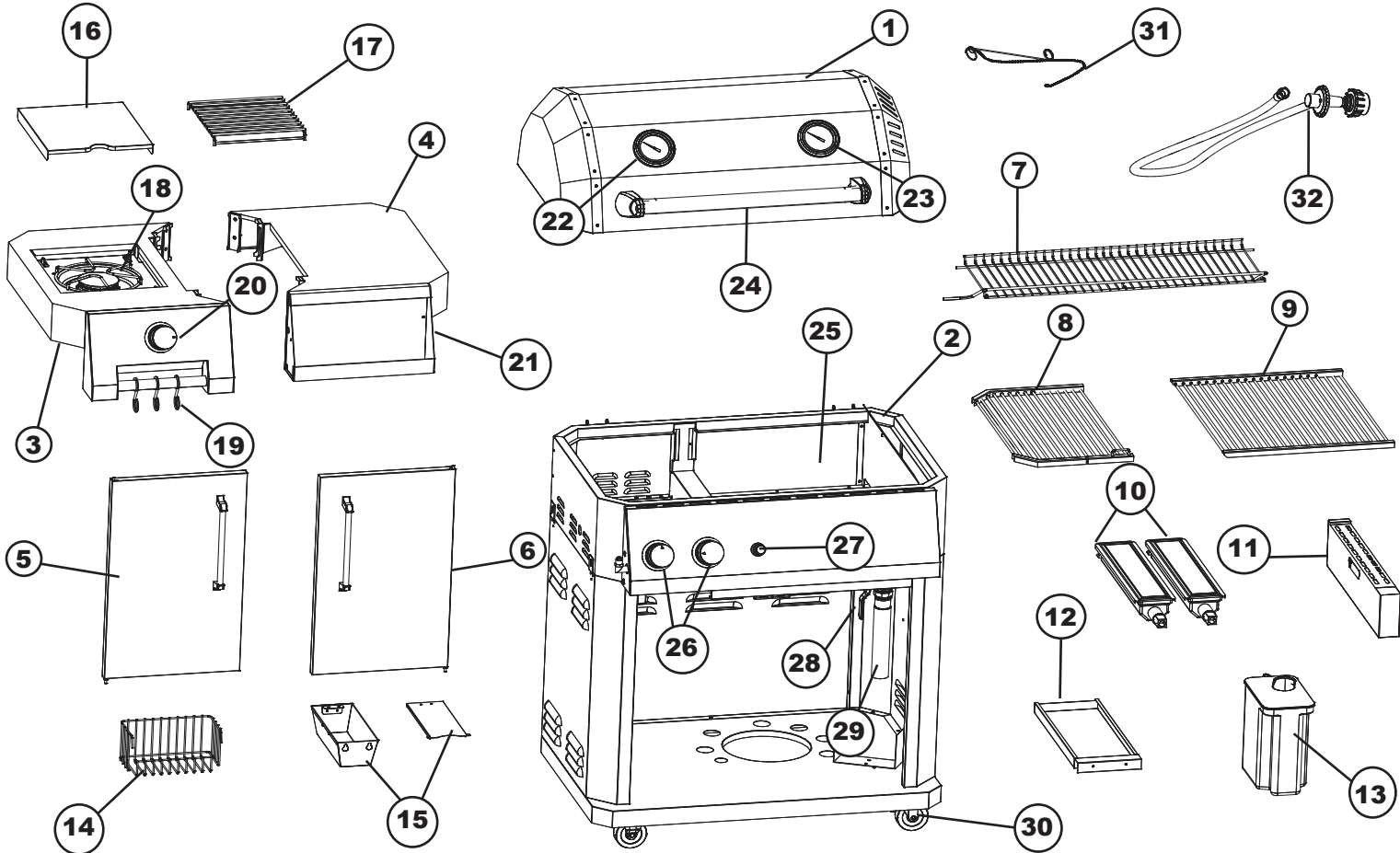

PART NO	QUANTITY	DESCRIPTION	PART NO	QUANTITY	DESCRIPTION
1	1	Grill Lid	17	1	Side Burner Grate
2	1	Grill Body	18	1	Side Burner
3	1	Left Side Shelf	19	3	Accessory Hook
4	1	Right Side Shelf	20	1	Side Burner Control Knob
5	1	Left Cabinet Door w/ Handle	21	1	Condiment Shelf
6	1	Right Cabinet Door w/ Handle	22	1	Searing Side Temperature Gauge
7	1	Warming Rack	23	1	Cooking Side Temperature Gauge
8	1	Searing Grate	24	1	Grill Lid Handle
9	1	Cooking Grate	25	1	Water Basin
10	2	Infrared Burner	26	2	Infrared Burner Control Knob
11	1	Flavor Chamber	27	1	Ignitor Button
12	1	Drip Tray	28	1	Drain Valve Control Knob
13	1	Drainage Jug	29	1	Drain Valve
14	1	Storage Basket	30	4	Caster Wheel
15	1	Wood Chip Tray w/ Lid	31	1	Matchstick w/Chain
16	1	Side Burner Lid	32	1	Regulator/Hose

HARDWARE LIST

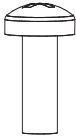

(A)
1/4"-20x0.79"
Screw
Qty-4

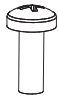

(B)
5/32"-32x0.31"
Screw
Qty-12



(C)
5/32"-32"x0.47"
Screw
Qty-2



(D)
5/32"-32
Nut
Qty-1



(E)
AA 1.5v Alkaline
Battery
Qty-1

REPLACEMENT PARTS LIST

PART NO	REPLACEMENT PART	ITEM NO	PART NO	REPLACEMENT PART	ITEM NO
1	Lid Kit	9903110001	20/26	Control Knob	9003110054
	Lid Kit-Black	9903110027	21	Condiment Shelf	9903110011
	Lid Kit-Blue	9903110028	22	Temperature Gauge Kit-Searing	9903110003
2	Grill Body Kit	9903110008	23	Temperature Gauge Kit-Cooking	9903110030
3	Left Side Panel Kit	9903110014	24	Lid Handle Kit	9903110004
4	Right Side Panel Kit	9903110013	27	Ignitor Assembly-Grill	9903110019
5	Left Door w/Handle Kit	9003110049		Ignitor Assembly-Side Burner	9903110020
	Left Door w/ Handle Kit-Black	9003110066	28/29	Drain Assembly Kit	9903110009
	Left Door w/ Handle Kit-Blue	9003110070	30	Caster Kit	9903110012
6	Right Door w/ Handle Kit	9003110050	31	Matchstick w/Chain	9003110051
	Right Door w/ Handle Kit-Black	9003110067	32	Gas Hose w/Regulator	9003110057
	Right Door w/ Handle Kit-Blue	9003110071		Gas Hose-Short	9003110056
7	Warming Rack	9003110058		Lid Hinge Kit	9903110002
8	Searing Grate	9003110060		Burner Support Kit	9903110007
9	Cooking Grate	9003110059		Inner Flange Kit	9903110010
10	Burner Kit	9903110006		Tank Blocker	9903110015
11	Flavor Chamber	9003110061		Paper Towel Holder Kit	9903110016
12	Drip Tray	9003110053		Gas Train Kit	9903110017
13	Drainage Jug w/Lid	9003110062		Spark Generator Kit	9903110018
14	Wire Accessory Basket	9003110052		Back Panel Kit	9903110024
15	Chip Tray Kit	9903110005		Cabinet Bottom Panel Kit	9903110025
16	Side Burner Cover Assembly	9903110021		Top Rail Kit	9903110026
17	Side Burner Grate	9003110055		Drainage Jug Bracket Kit	9903110031
18	Side Burner Kit	9903110022		Hardware Kit	9903110029
19	Side Burner Accessory Shelf	9903110023		Instruction Manual	9803110003



DO NOT RETURN TO RETAILER For Assembly Assistance, Missing or Damaged Parts
Call: MASTERBUILT Customer Service at 1-800-489-1581.
Please have Model Number and Serial Number available when calling.
These numbers are located on silver label on back of unit.

ASSEMBLY

- BEFORE ASSEMBLY READ ALL INSTRUCTIONS CAREFULLY.
- ASSEMBLE UNIT ON A CLEAN, FLAT SURFACE.
- TOOLS NEEDED: ADJUSTABLE WRENCH, PHILLIPS HEAD SCREWDRIVER
- UNIT IS HEAVY. DO NOT ASSEMBLE WITHOUT ASSISTANCE.

STEP 1

Loosen top screws (A) on side bracket as shown. Remove bottom screws (A) and place aside to be used later.

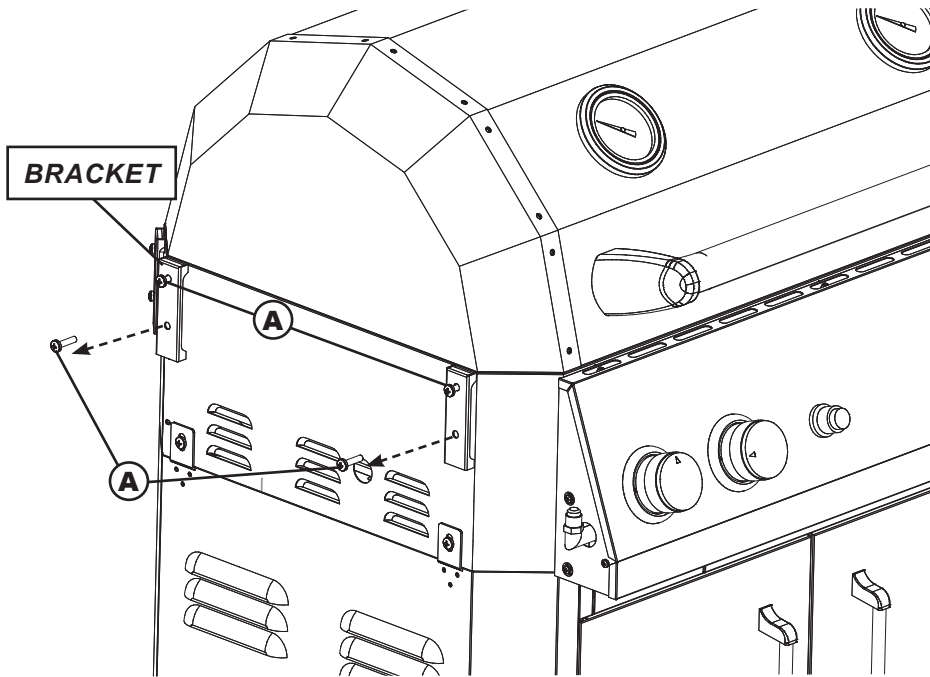

STEP 2

Use screws (B) to attach left fascia to left side shelf (3) as shown.

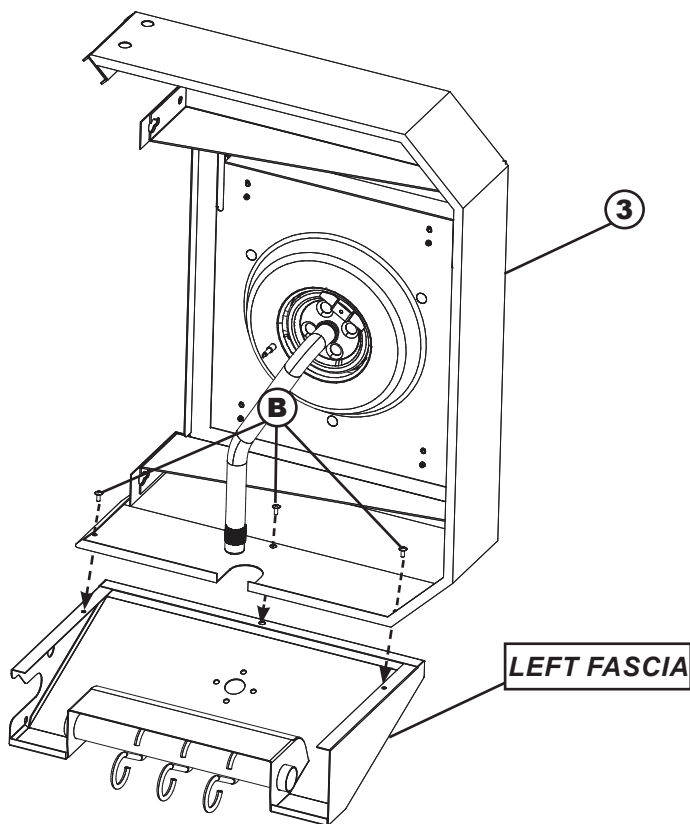

ASSEMBLY

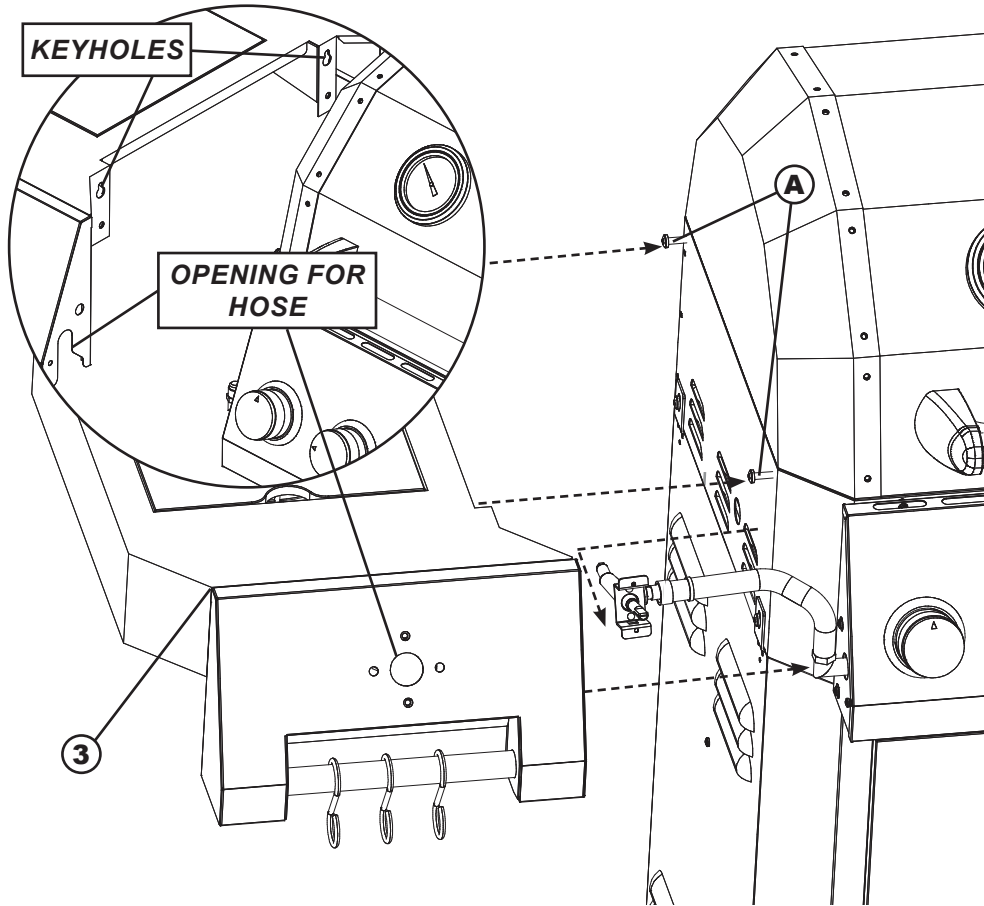

This step requires assistance. Get a helper!

STEP 3

Note: Helper will need to hold shelf in place while hose is correctly positioned.

Align keyholes on left side shelf (3) with screws (A). Position hose through openings on side shelf as shown. Gently press down on shelf to secure screws into keyholes.

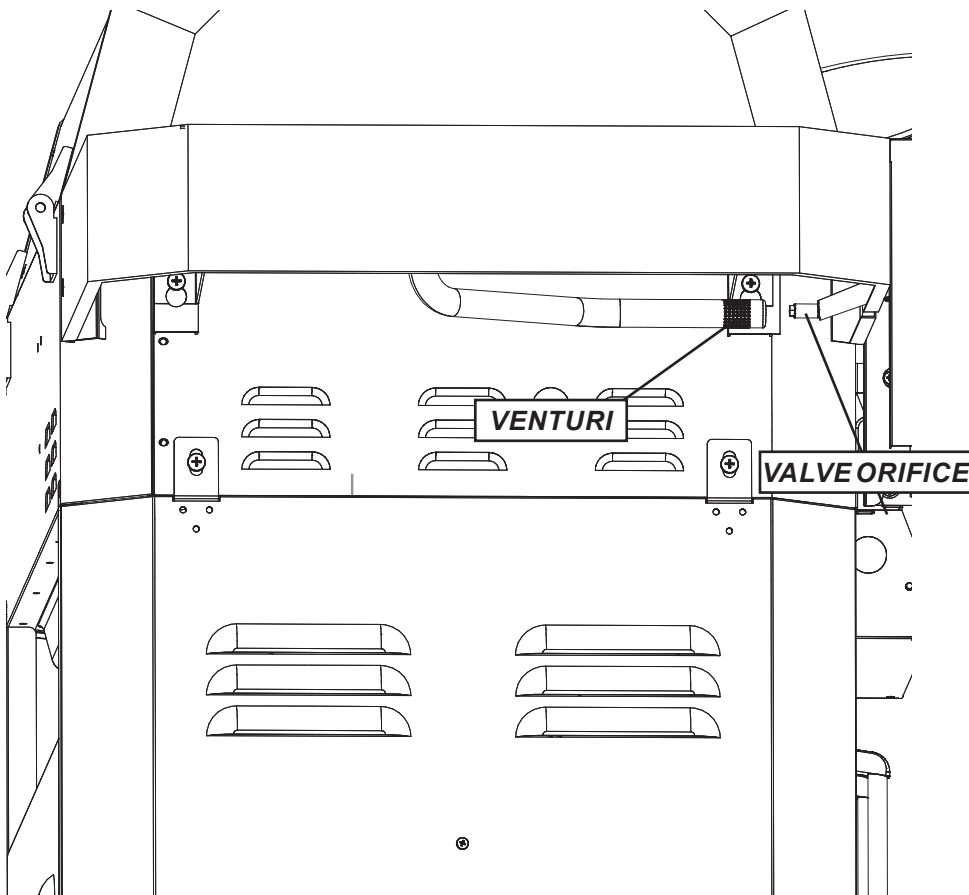

STEP 4

Insert valve orifice into venturi.

Do not fully tighten screws.

STEP 5

Reattach screws (A) from Step 1 as shown.

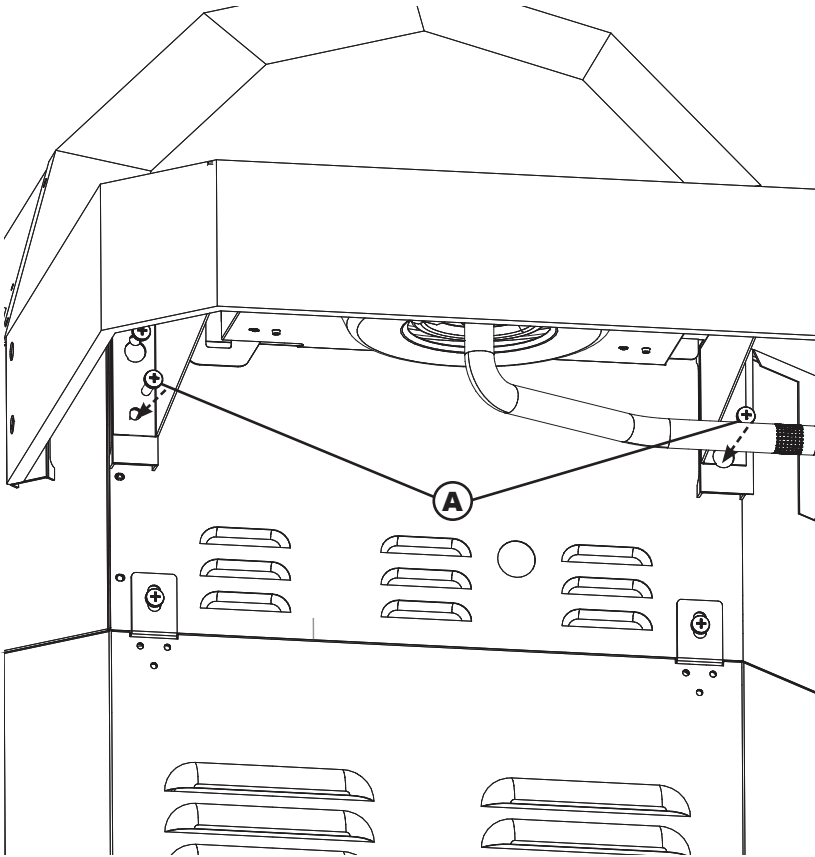

Do not fully tighten screws.

STEP 6

Note: Make sure bracket top and bottom are positioned correctly before attaching to grill.

Slide back bracket in between left side shelf (3) and grill body (2) as shown. Secure using screws (A).

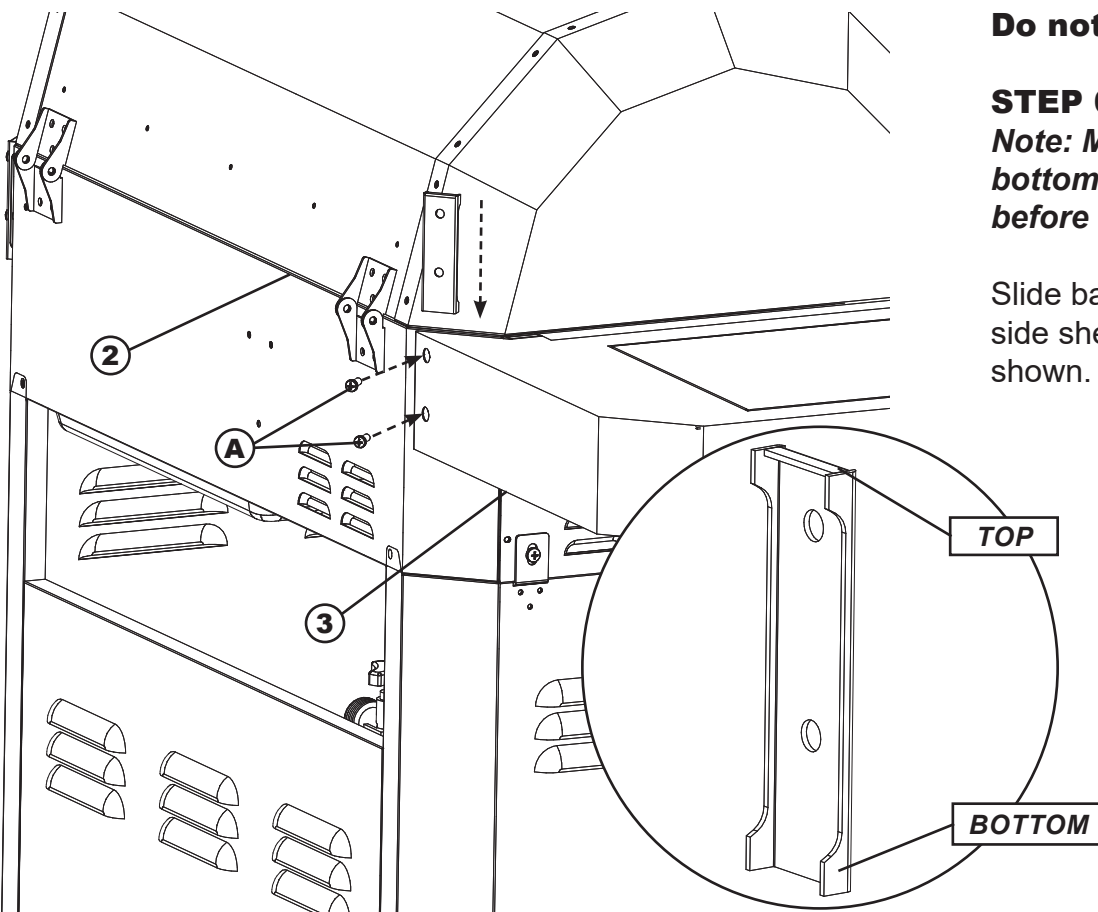

Do not fully tighten screws.

STEP 7

Use screw (B) to secure left side shelf (3) to grill body (2).

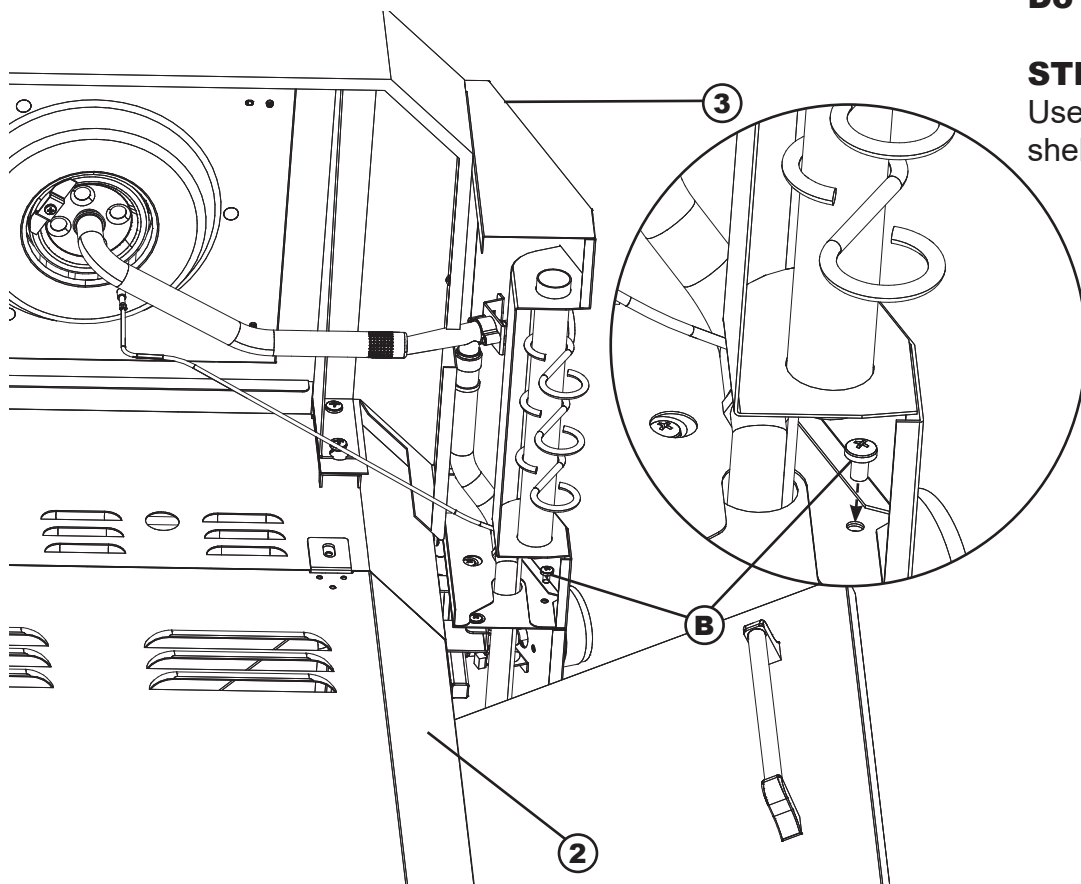

STEP 8

Note: Make sure hardware holes on valve orifice are correctly aligned with holes for bezel attachment.

Attach bezel to left side shelf (3) using screws (B). Press side burner control knob (20) onto front of shelf as shown.

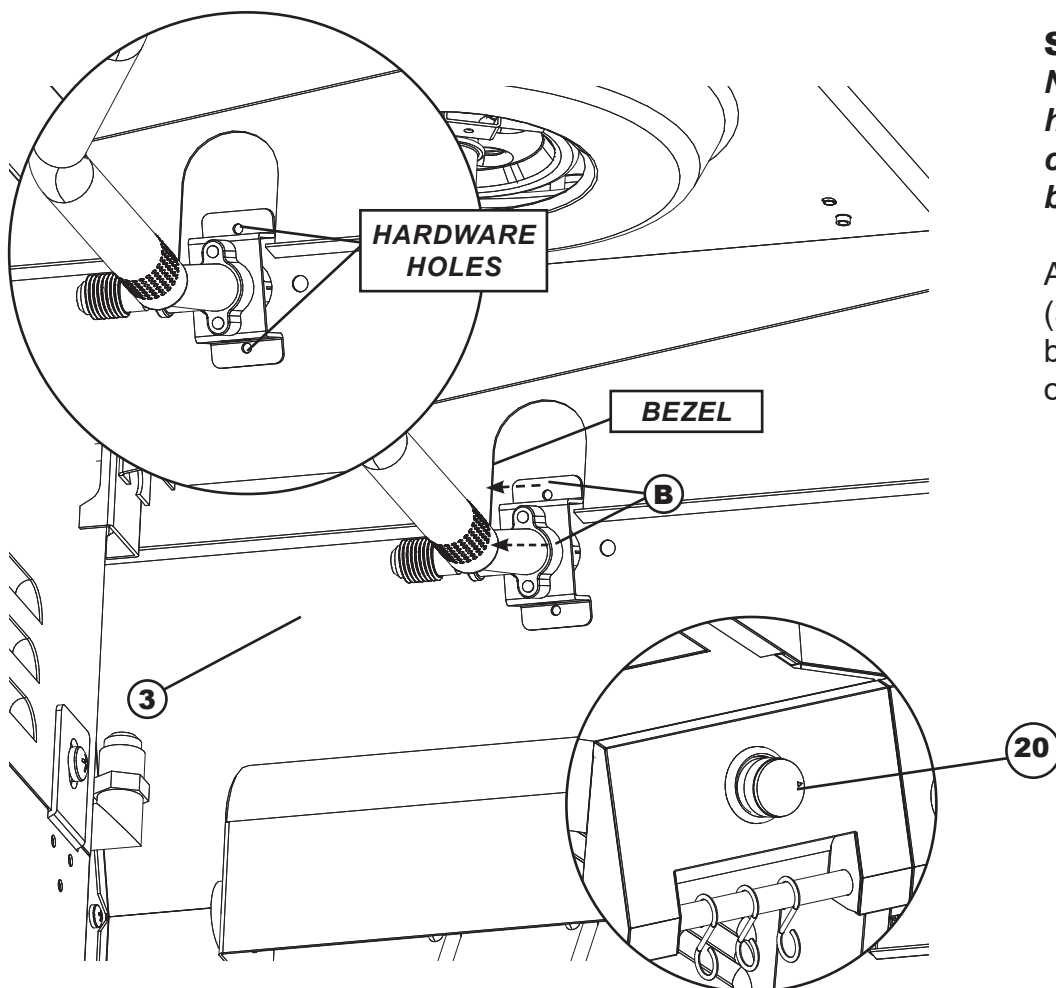

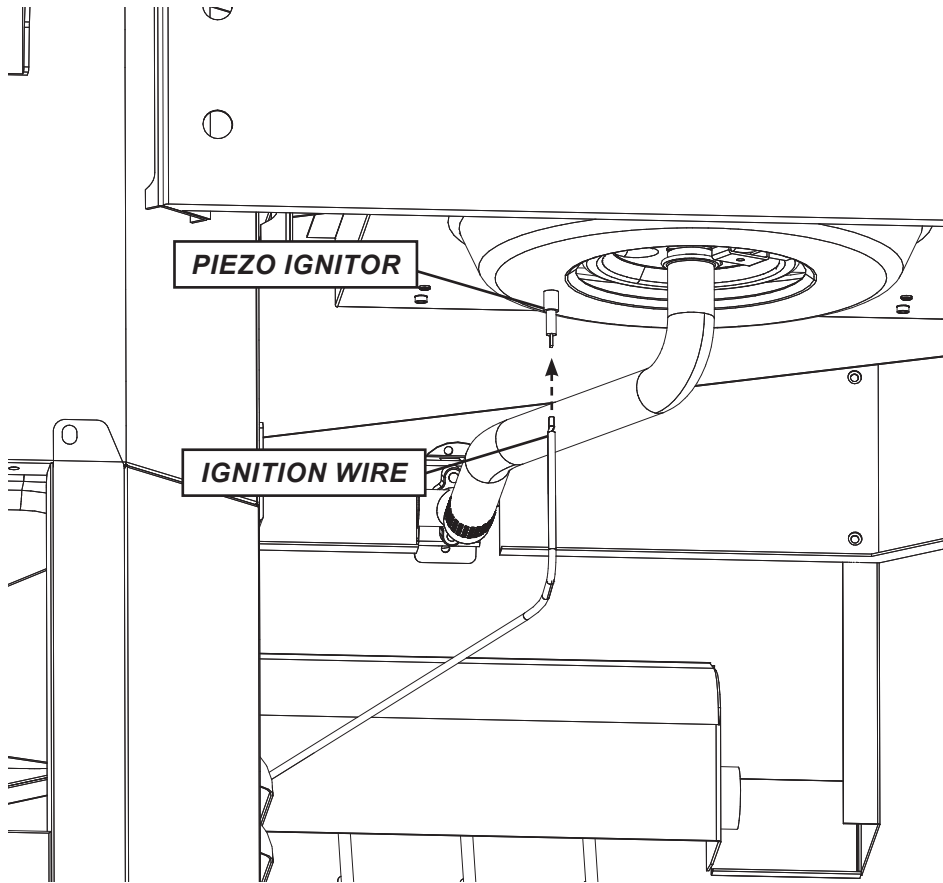

STEP 9

Firmly attach ignition wire to piezo ignitor on side burner as shown.

Tighten all hardware on left side shelf at this time.

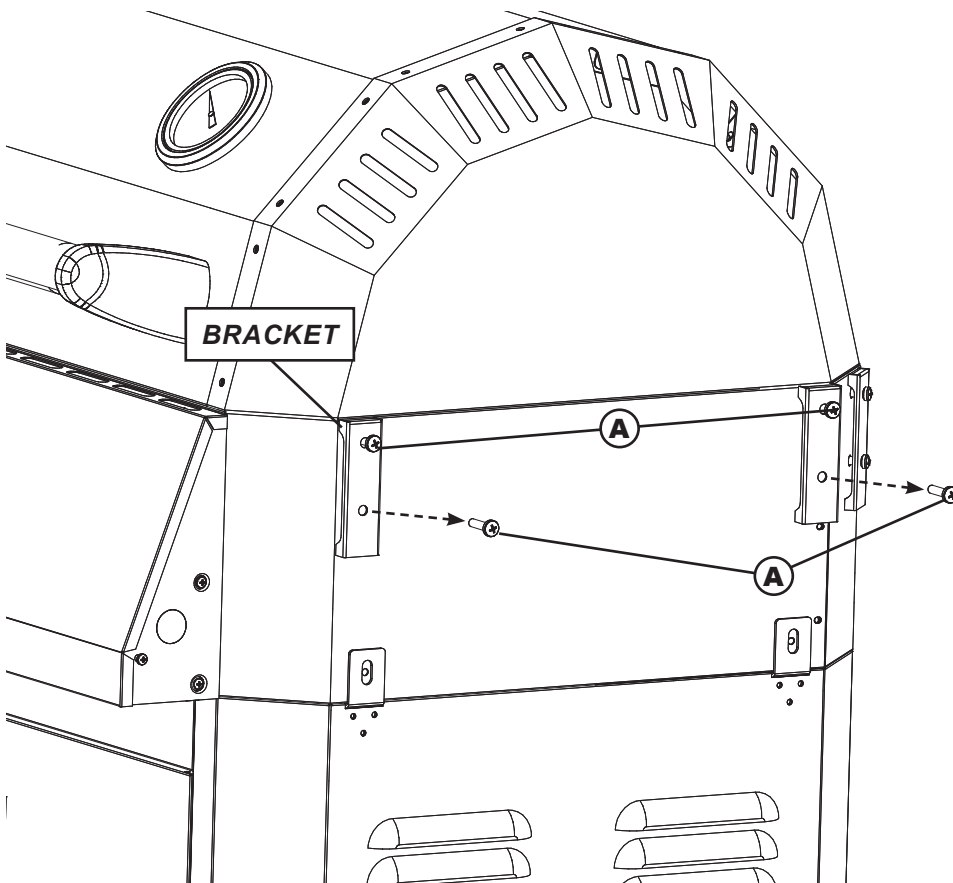

STEP 10

Loosen top screws (A) on side bracket as shown. Remove bottom screws (A) and place aside to be used later.

STEP 11

Note: Middle screw goes in opposite way of other screws.

Use screws (B) to attach condiment shelf (21) to right side shelf (4) as shown.

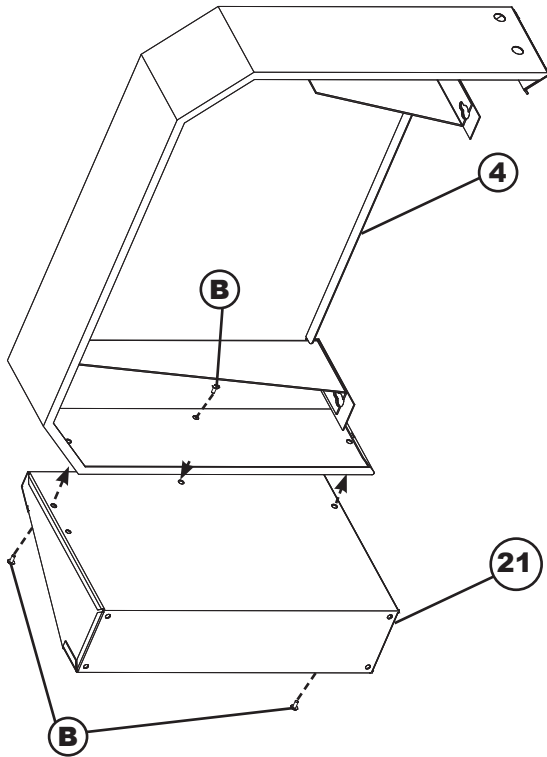

This step requires assistance. Get a helper!

STEP 12

Note: Helper will need to hold shelf in place.

Align keyholes on right side shelf (4) with screws (A). Gently press down on shelf to secure screws into keyholes.

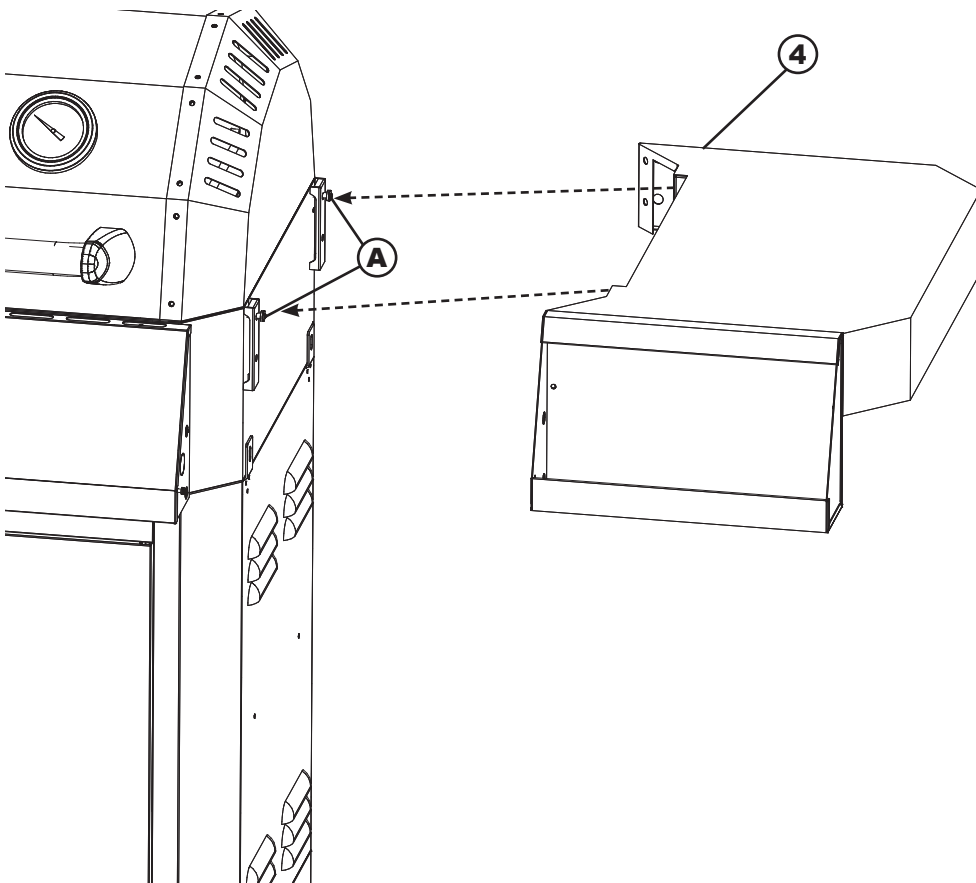

ASSEMBLY

Do not fully tighten screws.

STEP 13

Note: Make sure bracket top and bottom are positioned correctly before attaching to grill.

Slide back bracket in between right side shelf (4) and grill body (2) as shown. Secure using screws (A).

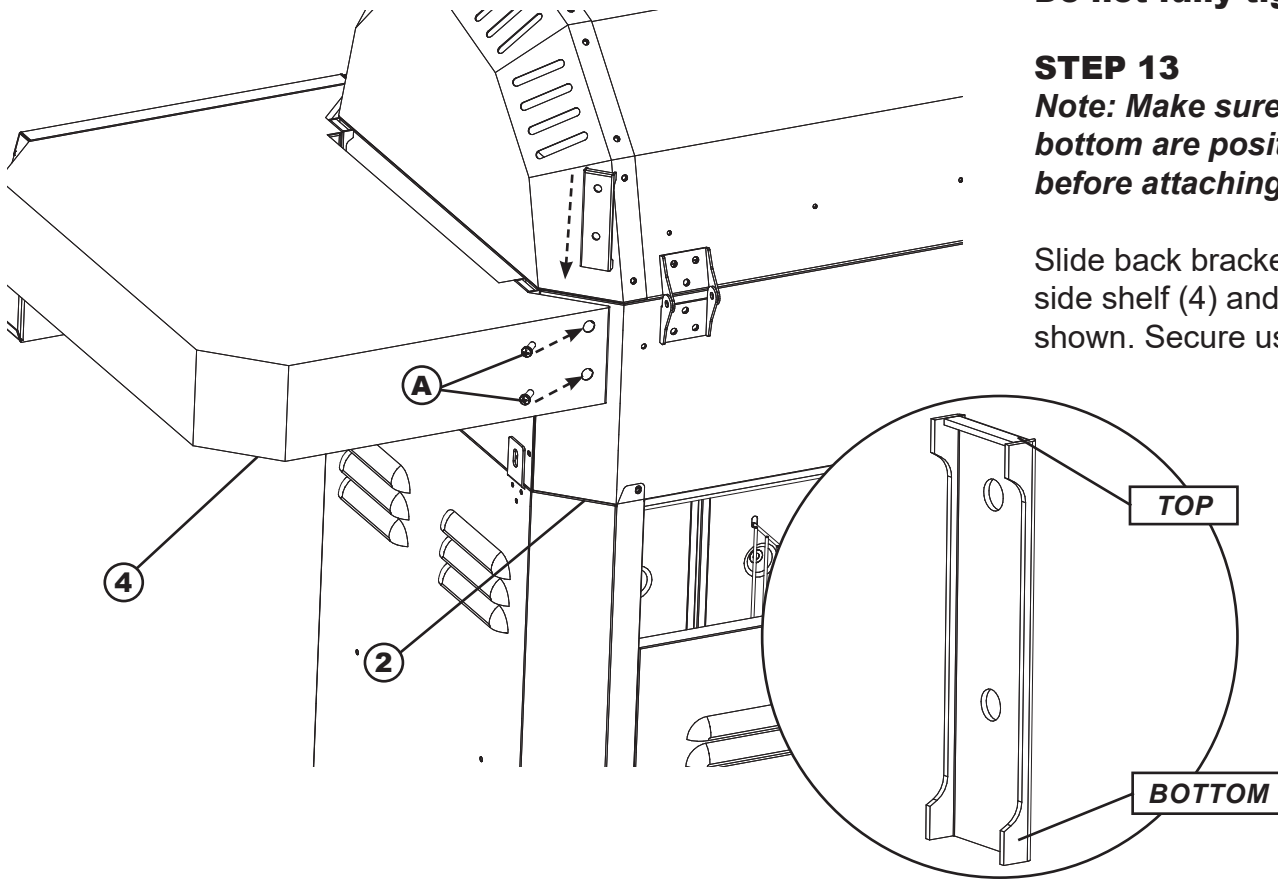

Do not fully tighten screws.

STEP 14

Reattach screws (A) from Step 10 as shown.

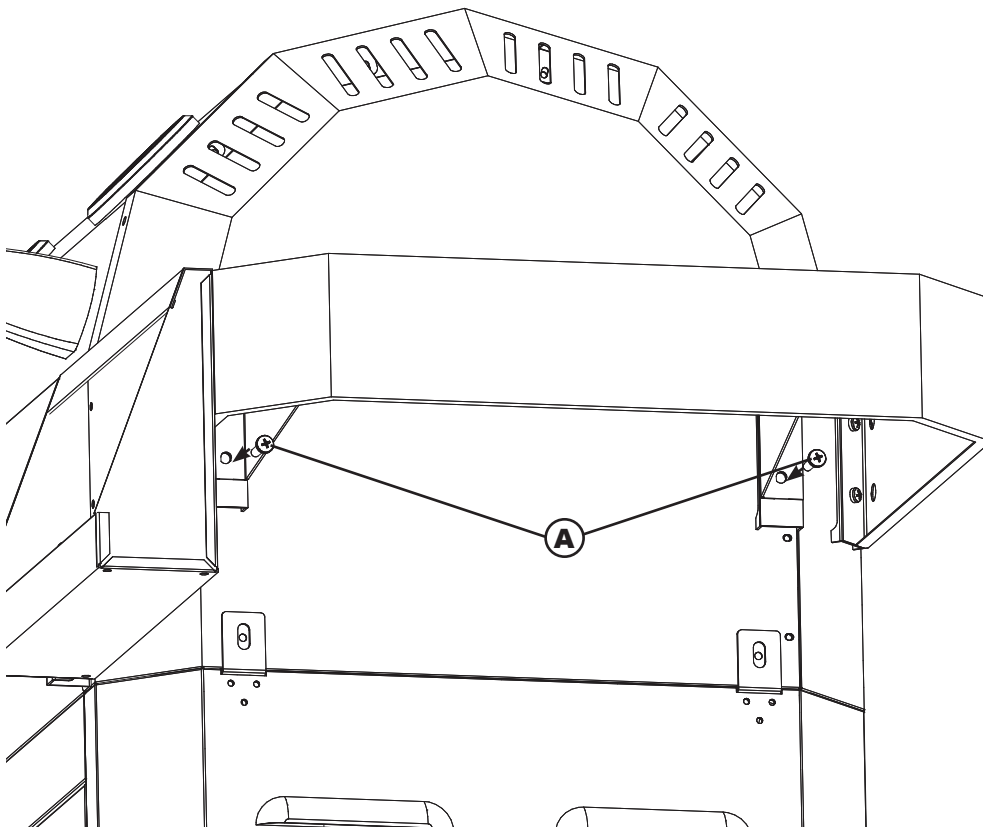

ASSEMBLY

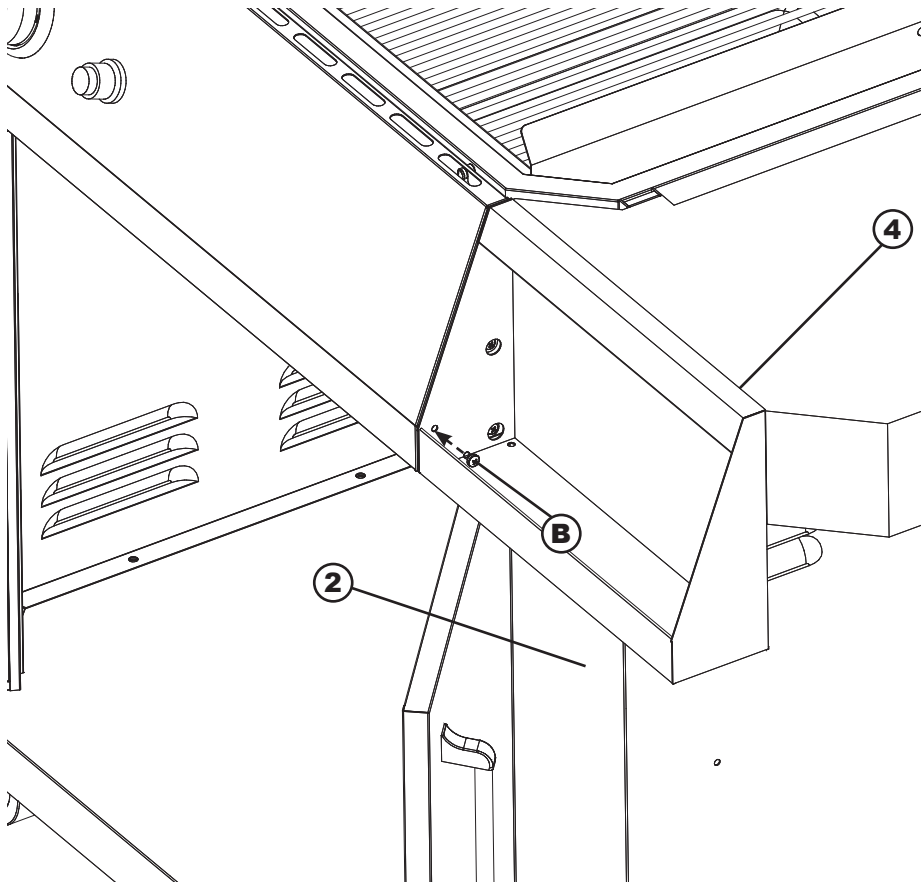

STEP 15

Use screw (B) to secure right side shelf (4) to grill body (2).

Tighten all hardware on right side shelf at this time.

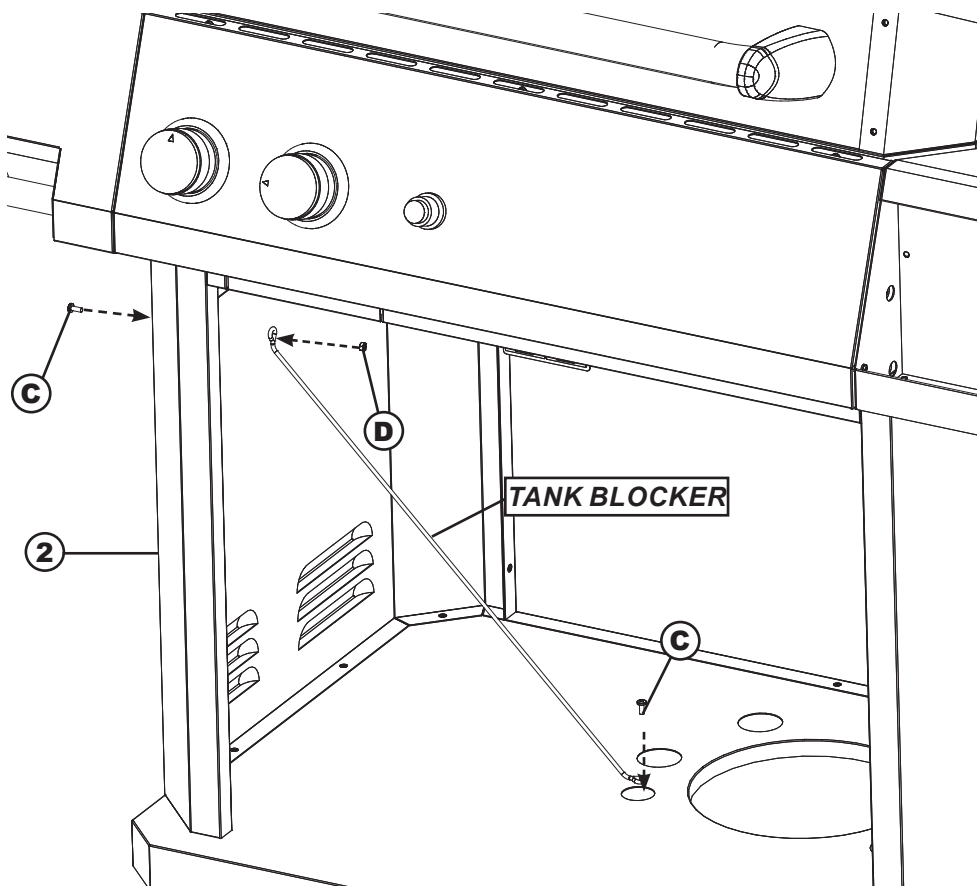

STEP 16

Align tank blocker with hardware holes on inside of grill body (2). Use screw (C) to attach tank blocker to bottom of grill body as shown. Secure other side of tank blocker using screw (C) and nut (D).

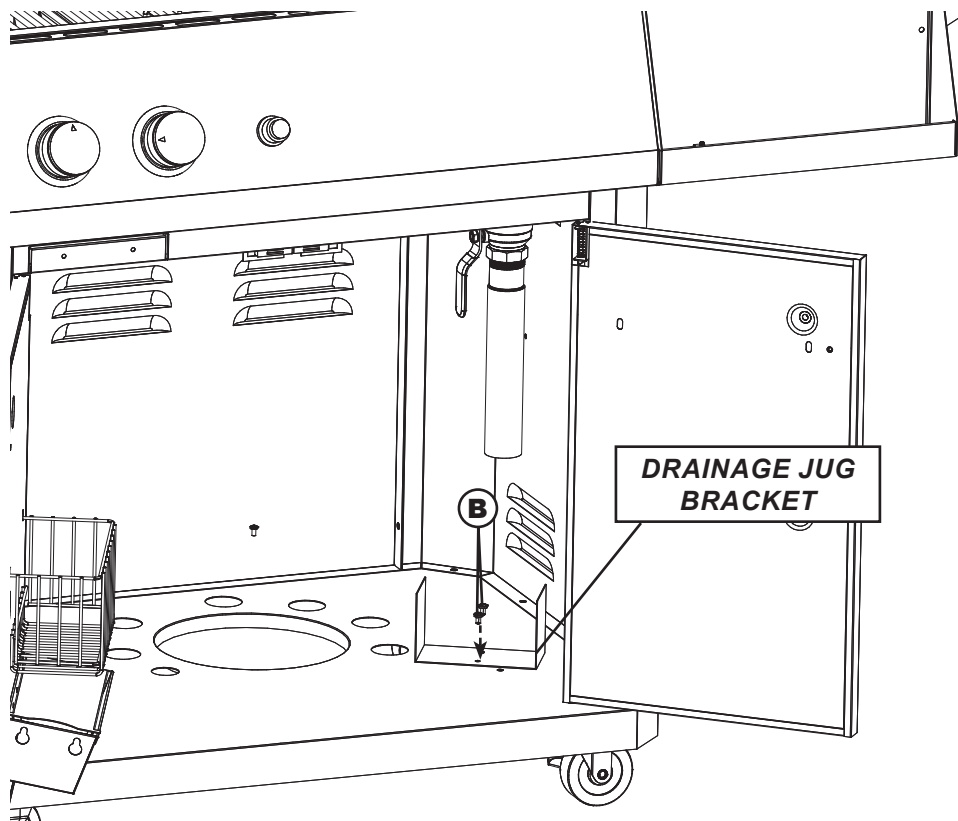

STEP 18

Attach drainage jug bracket inside grill cabinet using screws (B) as shown.

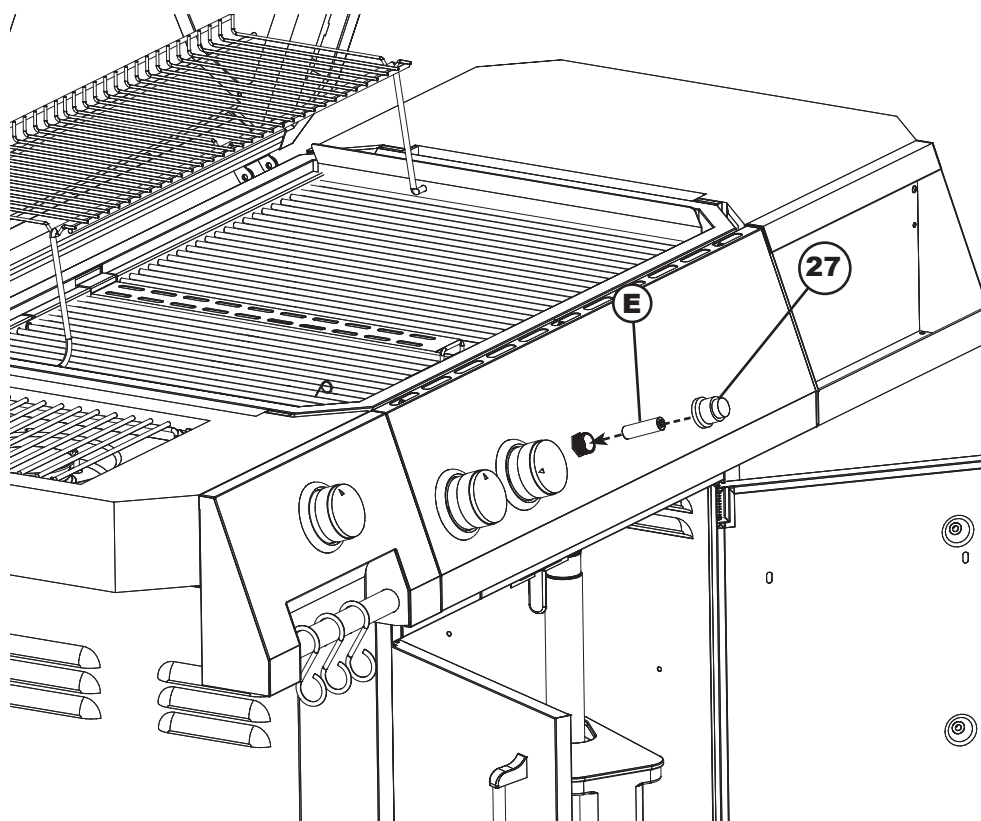

STEP 18

Unscrew ignitor button (27) and insert battery (E) with positive side facing outward as shown. Screw ignitor button back onto front panel.

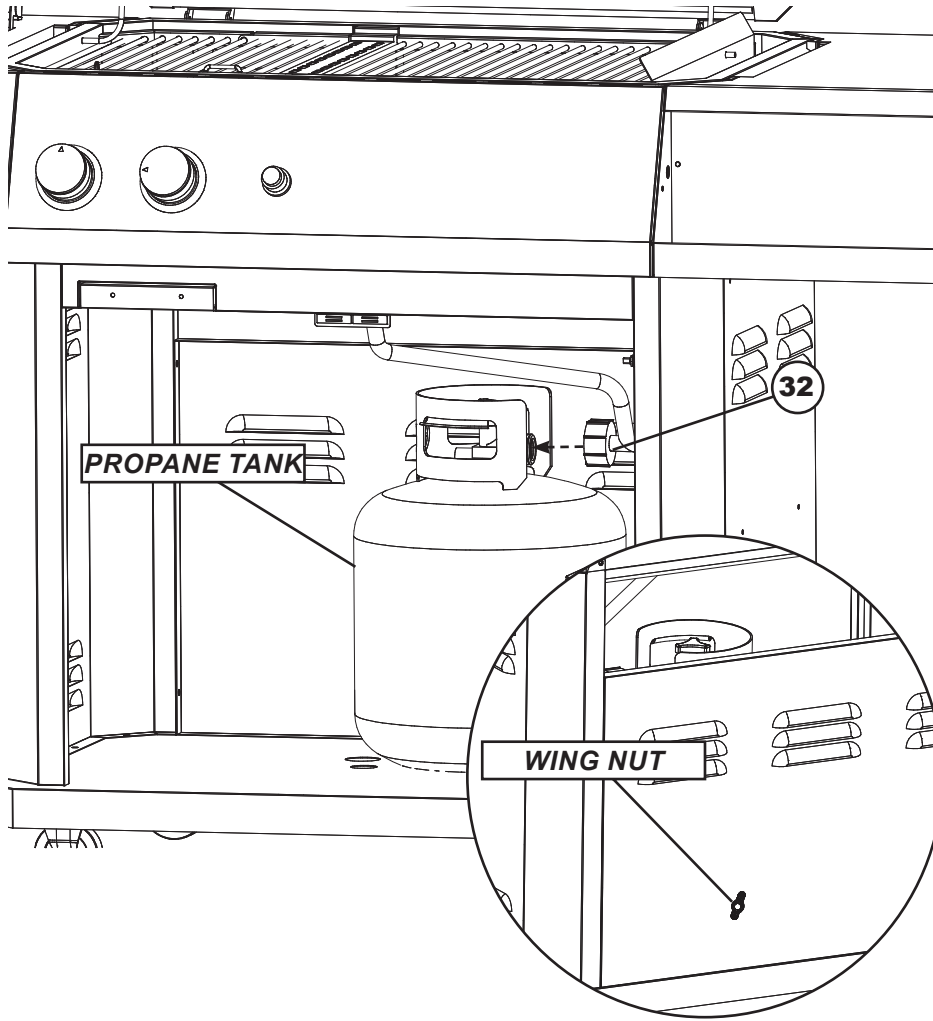

Some parts not shown for clarity.

STEP 19

Position propane tank in storage cabinet as shown. Attach regulator/hose (32) to propane tank.

Use wing nut on back of grill body to secure propane tank in place.

Assembly is complete!

Perform soapy water test to check for gas leaks before use (see pg 3).

Note: Soapy Water Test MUST be performed each time gas cylinder is connected to burner/hose, or each time it is used.

GRILL PREPARATION BEFORE FIRST TIME USE

Curing your grill will rid the unit of chemicals and oils left over by the manufacturing process allowing them to burn off.

1. Follow lighting instructions to light the grill (see pg. 18), turn the heat to HIGH and close the lid.
 2. Let the grill burn for about 30 minutes. Make sure temperature gets up to 400°F (204°C).
 3. Allow unit to cool completely.
 4. Wipe down inside of water basin with damp cloth to remove any residue.
 5. Using a napkin or cloth, rub a light coat of cooking oil on the grilling surface and inside of grill lid.
 6. Relight grill and burn the oil for 20 minutes.
- Cure your grill periodically to prevent excessive rust.

GRILL OPERATION

Grill Set-Up

1. Connect hose regulator to LP Gas Cylinder (see pg 4).
2. Fill jug with water to water basin fill line.
3. Make sure drain valve knob is in off position. Pour water into water basin.
4. Fill jug with juice or vinegar to flavor chamber fill line and pour into flavor chamber. Place jug back in storage cabinet.
6. Fill wood chip tray with wood chips (optional).

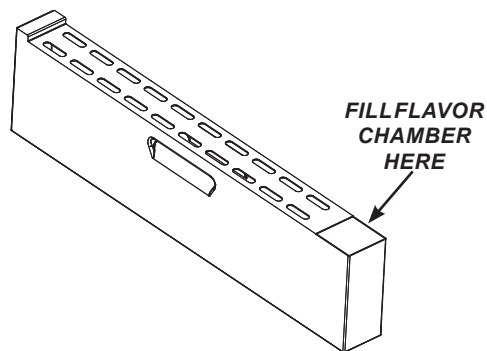
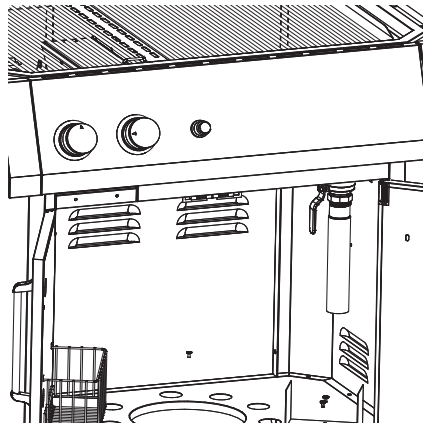

Lighting Instructions

1. Keep lid OPEN during lighting.
2. To ignite, turn burner knob to high.
3. Press and hold ignitor button.
4. If burners do not ignite within 10 seconds, release ignitor button and turn burner knob to OFF position. Wait 5 seconds and repeat Steps 1 through 3.

Note: *It is easier to light one burner at a time, rather than try to light them all at once.*

Match Light Instructions

1. Keep Lid OPEN during lighting.
2. Turn gas control valve on, turn gas cylinder valve on.
3. Place a long match into matchstick and light.
4. Place matchstick close enough to burner to ignite.

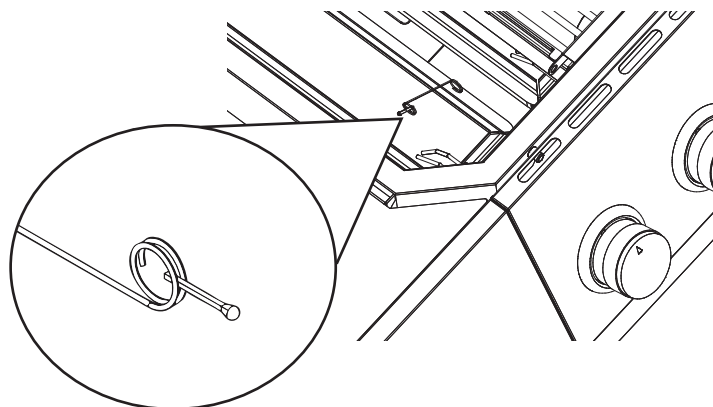

GETTING TO KNOW YOUR GRILL

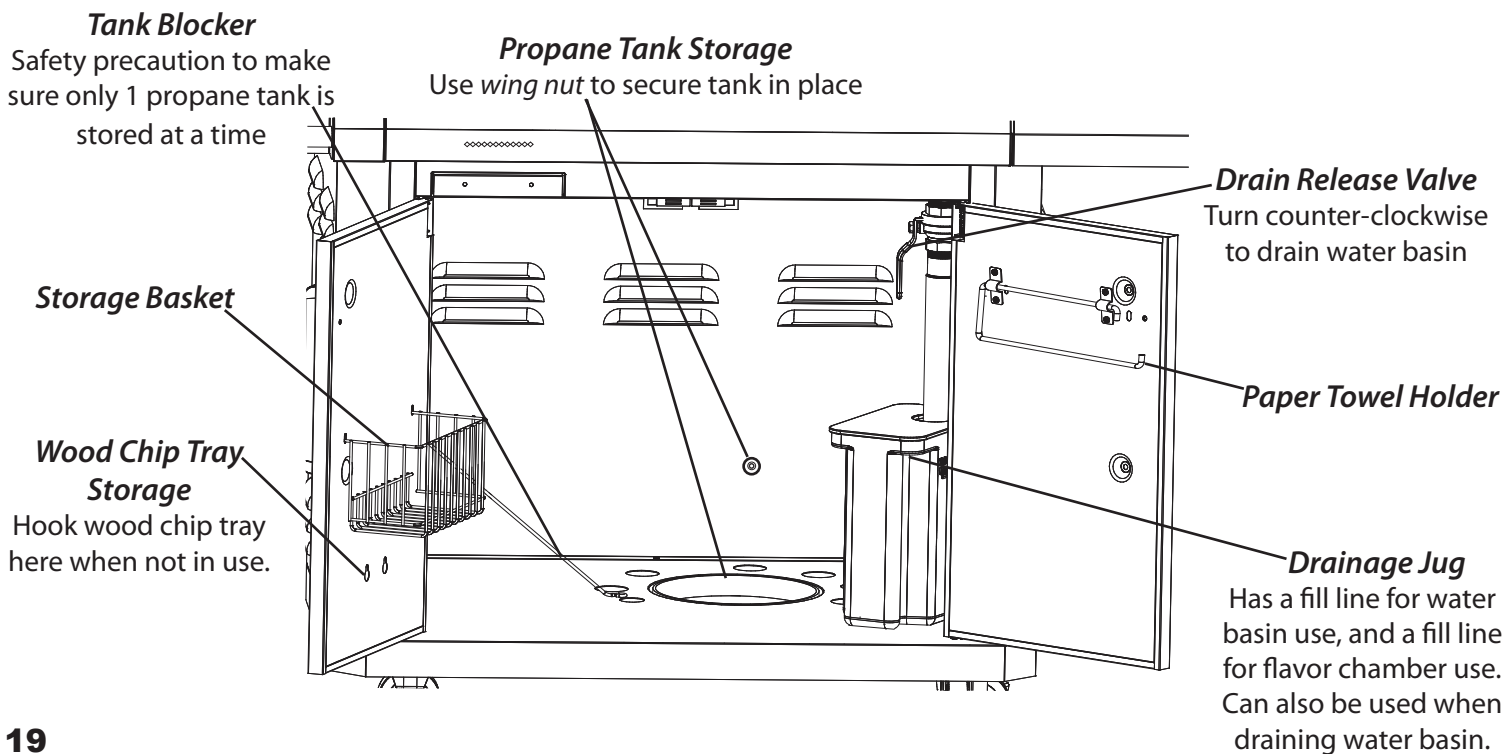
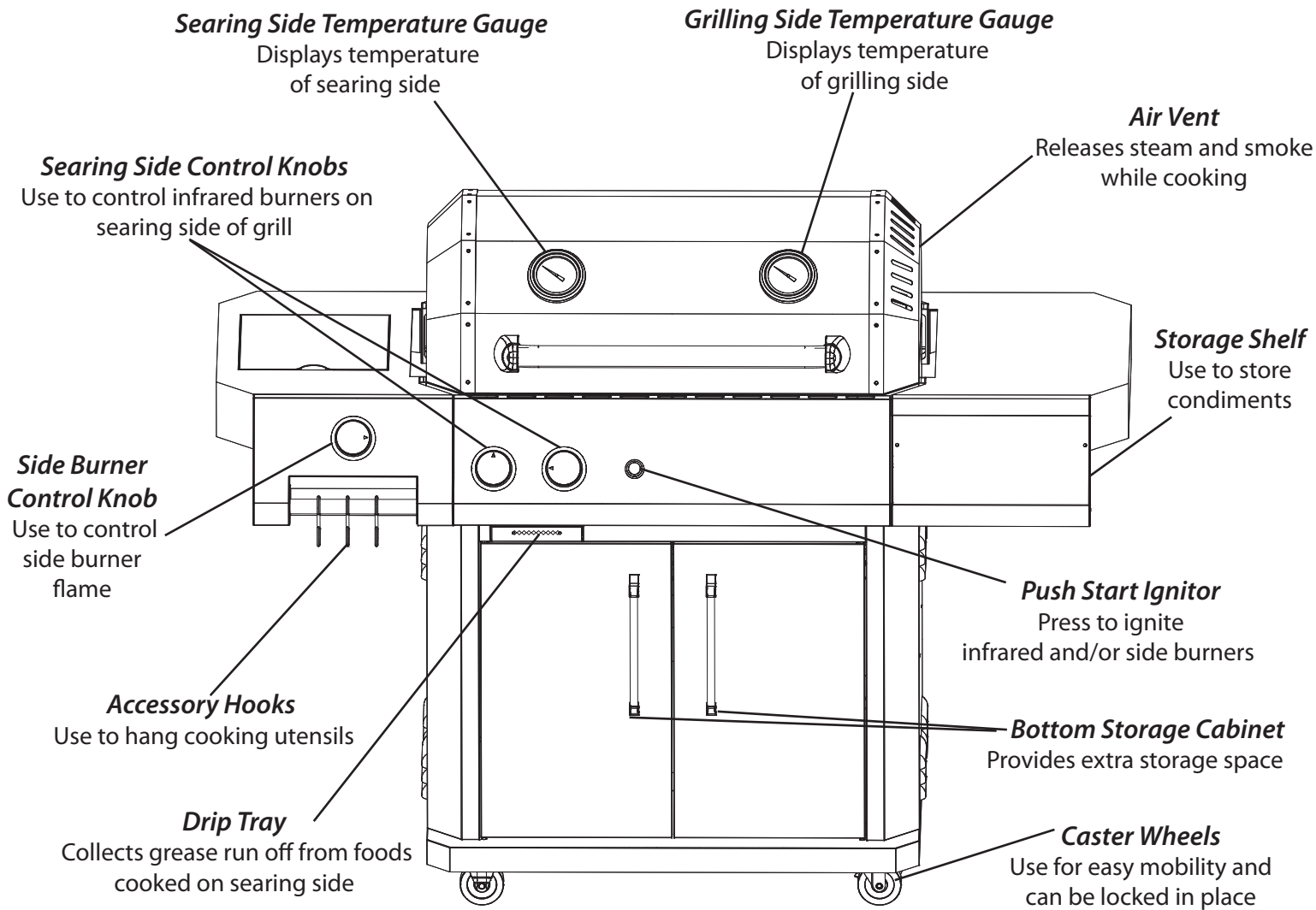

GETTING TO KNOW YOUR GRILL

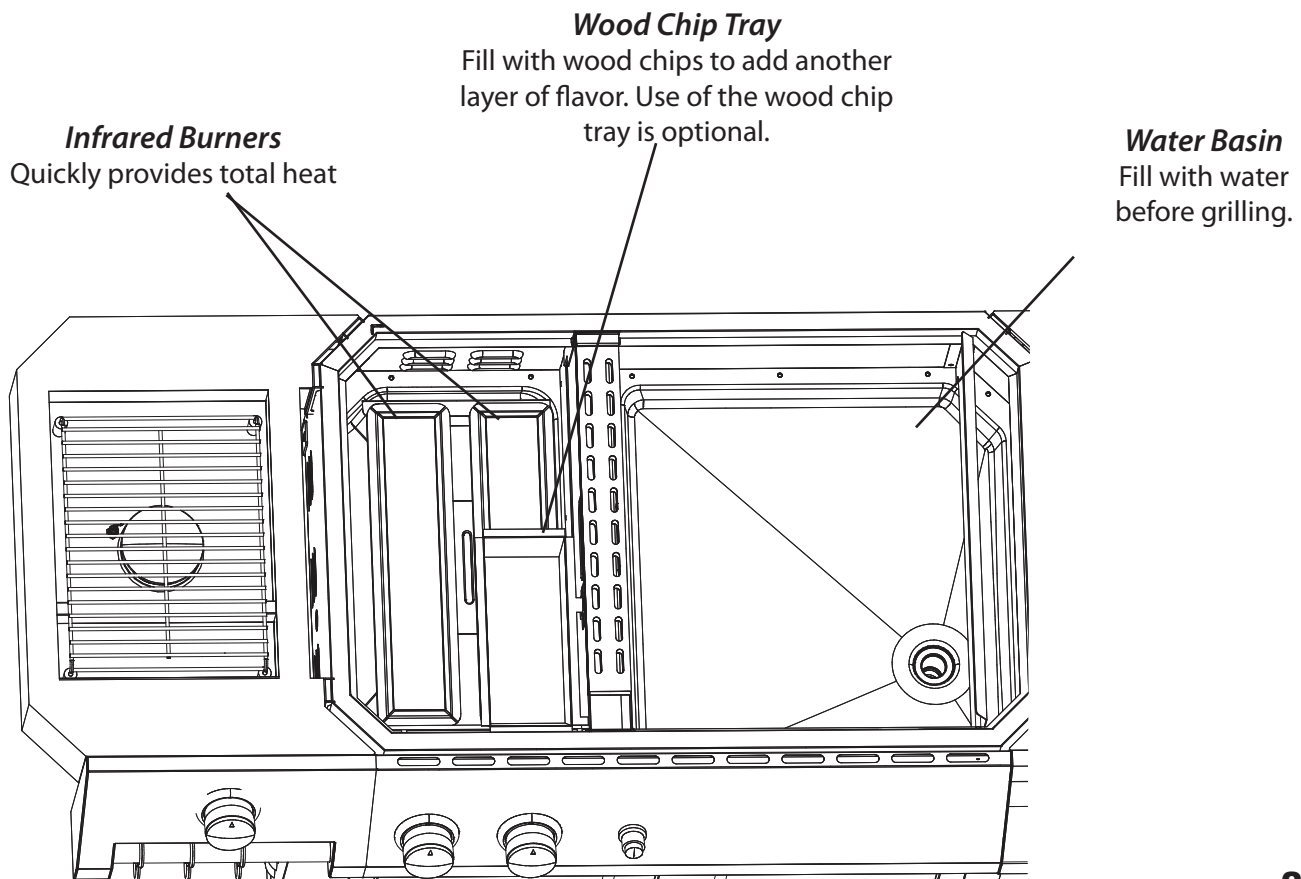
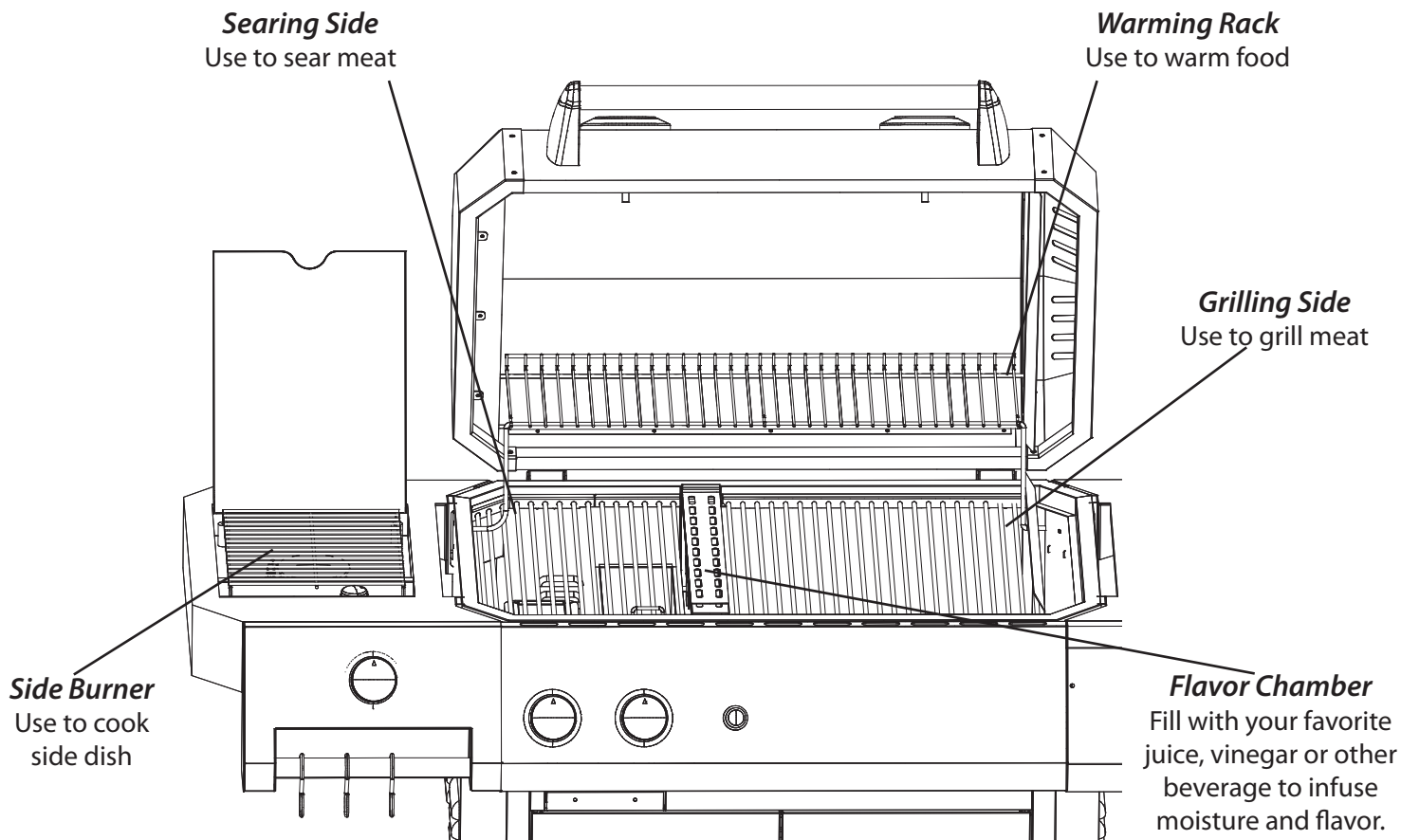

The Nfusion FlavorMaster provides five cooking methods in one grill.

Infrared Heat

- The left side of the unit is the searing side. Use infrared heat to sear meat or barbecue the conventional way. To obtain the desired brown or black crust, the meat surface must exceed 150°C (300°F), so searing requires the meat surface be free of water. Food should be seared over very high heat then moved to the lower temperature side of the grilling surface.
- All burner control knobs can be adjusted to HIGH, MEDIUM, or LOW for cooking preference.
- Use additional side burner to cook your side dishes.

Top-down Convection Grill

- The right side of the unit is the grilling side. Cook food quickly and evenly from top down with minimal tending and no burning.

Steam System

- Water basin cooks via steam to keep food moist and juicy. Water basin must be used each time to ensure food does not overcook.

Liquid Flavor Chamber

- Add juice, vinegar or other beverages to the flavor chamber to infuse moisture and flavor.

Smoker

- Add another layer of flavor by using the wood chip tray. This feature is optional.

CLEANING & MAINTENANCE

- **ALWAYS ALLOW UNIT TO COOL COMPLETELY BEFORE HANDLING.**

1. Make sure jug is in place under drain valve. Turn drain release valve to drain water from water basin.
 2. Close drain valve. Remove jug and discard water.
 3. Empty flavor chamber. Fill with warm soapy water and rinse out. Turn upside down to dry.
 4. Empty wood chip tray. Wipe out with damp cloth.
 5. Use grill brush to clean cooking grate and searing grate.
 6. Wipe down inside of water basin to remove any residue.
 7. Empty drip tray. Wash with warm soapy water and rinse well. Dry thoroughly.
 8. Use stainless steel cleaner and a soft cloth for exterior surfaces only. Wipe in the direction of the grain.
- Do not use oven cleaner, abrasive cleaners, or abrasive cleaning pads on any surfaces of the grill.
 - Store grill in a protected area.
 - Inspect all hardware in assembled parts for tightness on a regular basis to insure unit is in safe working condition.
 - Clean grill before and after each use.

BBQ BURGERS

- ¼ cup catsup
- 2 tbsp steak sauce
- 1 tbsp water
- 1 tsp sugar
- 1 tsp vinegar
- 1 clove garlic, minced
- 1 lb lean ground beef
- ¼ tsp salt
- ¼ tsp black pepper
- 4 hamburger buns, split and toasted

For sauce, in small saucepan combine catsup, steak sauce, water, sugar, vinegar, garlic, and if desired, hot pepper sauce. Bring to boiling, and reduce heat. In a medium bowl combine ground beef, salt, and pepper. Shape meat mixture into four ¾ inch thick patties.

Grill patties on the rack of an uncovered grill directly over medium coals for 14-18 minutes or until meat reaches 160° F degrees internally. Turn patties once during cooking and brush once or twice with sauce during the last five minutes.

Serve burgers on buns.

Optional: few dashes bottled hot pepper sauce, American cheese slices, lettuce leaves, tomato slices, onion slices, and pickle slices.

TANGY PEANUT-SAUCED RIBS

- 4 lbs meaty pork spareribs or pork loin back ribs
- ¼ cup hot water
- ¼ cup peanut butter
- 2 tbsp lime juice
- 2 tbsp sliced green onion
- ½ tsp grated fresh ginger or ¼ tsp ground ginger
- ¼ tsp ground red pepper

Trim fat from ribs. Cut ribs into 4-6 serving size pieces. Place ribs bone side down. Cover and grill for 1 to 1 ¾ hours or until tender. Meanwhile, for sauce, in a small saucepan gradually stir hot water into peanut butter (mixture will stiffen at first). Stir in lime juice, green onion, ginger, and red pepper. Cook and stir over low heat until heated through. Spoon sauce over ribs.

HERB-MUSTARD CHICKEN QUARTERS

2 tbsp creamy Dijon-style mustard blend

1 tbsp snipped fresh parsley

1 tbsp snipped fresh oregano or 1 tsp dried oregano crushed

1 tbsp water

1/8 tsp ground red pepper

3 to 3 ½ lb whole broiler-fryer chicken, cut into quarters

For sauce, in a small bowl combine mustard, parsley, oregano, water and red pepper. Cover and chill until ready to use. Optional to remove skin.

Place chicken bone side down. Cover and grill for 50-60 minutes or until chicken is no longer pink. (170° F degrees for breast and 180° F degrees for dark meat). Brush the pieces with sauce occasionally during the last 10 minutes of grilling.

FOR MORE TANTALIZING RECIPES
AND COOKING TIPS VISIT US ONLINE AT
WWW.MASTERBUILT.COM



WOOD SMOKING GUIDE FOR MEATS

WOOD FLAVOR	POULTRY	FISH	HAM	BEEF	PORK	LAMB
Hickory Pungent, smoky, bacon-like flavor	✓	✓	✓	✓	✓	
Mesquite Sweet and delicate flavor	✓			✓		✓
Alder Delicate, wood smoke flavor	✓	✓			✓	
Pecan Bold and hearty flavor	✓	✓			✓	
Maple Sweet, subtle flavor	✓				✓	
Apple Sweet, delicate flavor	✓	✓			✓	
Cherry Sweet, delicate flavor	✓				✓	



WARNING



COMBUSTION BY-PRODUCT PRODUCED WHEN USING THIS PRODUCT CONTAINS CHEMICALS KNOWN TO THE STATE OF CALIFORNIA TO CAUSE BIRTH DEFECTS, OTHER REPRODUCTIVE HARM, OR CANCER.

THE MATERIALS USED IN THIS PRODUCT MAY CONTAIN LEAD A CHEMICAL KNOWN TO THE STATE OF CALIFORNIA TO CAUSE BIRTH DEFECTS AND OTHER REPRODUCTIVE HARM.

LIMITED WARRANTY

Masterbuilt warrants its products to be free from defects in material and workmanship under proper assembly, normal use and recommended care for 90 days from the date of original retail purchase.

Masterbuilt warranty does not cover paint finish as it may burn off during normal use.

Masterbuilt warranty does not cover rust of the unit.

Masterbuilt requires reasonable proof of purchase for warranty claims and suggests that you keep your receipt. Upon the expiration of such warranty, all such liability shall terminate.

Within the stated warranty period, Masterbuilt, at its discretion, shall repair or replace defective components free of charge with owner being responsible for shipping. Should Masterbuilt require return of component(s) in question for inspection Masterbuilt will be responsible for shipping charges to return requested item.

This warranty excludes property damage sustained due to misuse, abuse, accident, damage arising out of transportation, or damage incurred by commercial use of this product.

This expressed warranty is the sole warranty given by Masterbuilt and is in lieu of all other warranties, expressed or implied including implied warranty, merchantability, or fitness for a particular purpose.

Neither Masterbuilt nor the retail establishment selling this product, has authority to make any warranties or to promise remedies in addition to or inconsistent with those stated above.

Masterbuilt's maximum liability, in any event, shall not exceed the purchase price of the product paid by the original consumer/ purchaser. Some states do not allow the exclusion or limitation of incidental or consequential damages. In such a case, the above limitations or exclusions may not be applicable.

California residents only: Notwithstanding this limitation of warranty, the following specific restrictions apply; if service, repair, or replacement of the product is not commercially practical, the retailer selling the product or Masterbuilt will refund the purchase price paid for the product, less the amount directly attributable to use by the original buyer prior to the discovery of the nonconformity. Owner may take the product to the retail establishment selling this product in order to obtain performance under warranty.

This expressed warranty gives you specific legal rights, and you may also have other rights which vary from state to state.



Go Online www.masterbuilt.com
or complete and return to
Attn: Warranty Registration
Masterbuilt Mfg. Inc.
1 Masterbuilt Court - Columbus, GA 31907

Name: _____ Address : _____ City: _____

State/Province: _____ Postal Code: _____ Phone Number: (____) - _____

E-mail Address: _____

*Model Number: _____ *Serial Number: _____

Purchase Date: ____ - ____ - ____ Place of Purchase: _____

**Model Number and Serial Number are located on silver label on back of unit.*



**Masterbuilt Manufacturing, Inc.
1 Masterbuilt Ct.
Columbus, GA 31907
Customer Service 1-800-489-1581
www.masterbuilt.com**