

This Owner's Manual is provided and hosted by Appliance Factory Parts.

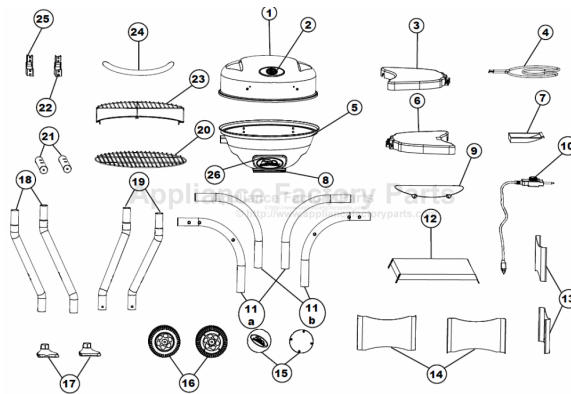

MASTERBUILT 20150213 Owner's Manual

[Shop genuine replacement parts for MASTERBUILT
20150213](#)



[Find Your MASTERBUILT Grill Parts - Select From 589 Models](#)

----- Manual continues below -----



Masterbuilt Manufacturing, Inc.
 1 Masterbuilt Ct.
 Columbus, GA 31907
 Customer Service 1-800-489-1581
 www.masterbuilt.com



ASSEMBLY, CARE & USE MANUAL
WARNING & SAFETY INFORMATION
 ELECTRIC PATIO GRILL
 MODELS 20150112, 20150213, 20150513, 20150613, 20150713
 THIS PRODUCT IS FOR OUTDOOR USE ONLY

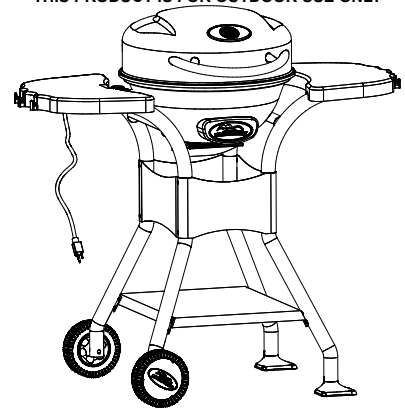

Manual Code: 9815110001 122211-02JH

Approximate assembly time : 30 minutes

Tool needed for assembly: Phillips Head Screwdriver

! WARNING !	! WARNING !
<p>Use only outdoors where it is well ventilated.</p> <p>Fuel, such as charcoal briquettes, wood or heat pellets, are not to be used in the unit.</p>	<p>This manual contains important information necessary for the proper and safe use of this unit.</p> <p>Read and follow all warnings and instructions before using grill and during use.</p> <p>Keep this manual for future reference.</p>
<p>Failure to follow these warnings and instructions properly could result in personal injury or death.</p>	



GENERAL WARNINGS AND SAFETY INFORMATION



READ ALL INSTRUCTIONS

When using electrical appliances, basic safety precautions should always be followed including the following:

- Cannot be operated for more than 3 hours.
- Use GFI protected electrical outlet to reduce the risk of electrical shock.
- For outdoor use only. Do not operate in an enclosed area.
- Unit **MUST** be on the ground. Do not place unit on tables or counters. Do **NOT** move unit across uneven surfaces.
- Do not plug in electric grill until fully assembled and ready for use.
- Use only approved grounded electrical outlet.
- Do not use during an electrical storm.
- Do not expose electric grill to rain or water at anytime.
- To protect against electrical shock do not immerse cord, plug or control panel in water or other liquid.
- Do not operate any appliance with a damaged cord or plug, or after appliance malfunctions or has been damaged in any manner. Contact Masterbuilt Customer Service for assistance at 1-800-489-1581.
- Keep a fire extinguisher accessible at all times while operating electric smoker.
- Do not let cord hang touch hot surfaces.
- Do not place on or near a hot gas or electric burner, or in a heated oven.
- Keep children and pets away from electric smoker at all times. Do not allow children to use electric smoker. Close supervision is necessary should children or pets be in area where electric smoker is being used.
- Fuel, such as charcoal briquettes, wood or heat pellets, are not to be used in electric grill.
- Never use electric grill as a heater (READ CARBON MONOXIDE HAZARD ON FRONT COVER).
- Use electric grill only on a level, stable surface to prevent tipping.
- Electric grill is HOT while in use and will remain HOT for a period of time afterwards. Use caution.
- Do not touch HOT surfaces.
- Do not allow anyone to conduct activities around electric grill during or following its use until the unit has cooled. Electric grill is HOT during operation and remains HOT for a period of time following use.
- The use of alcohol, prescription or non-prescription drugs may impair the user's ability to properly assemble or safely operate electric smoker.
- Avoid bumping or impacting electric grill.
- Never move electric grill when in use. Allow electric grill to cool completely before moving or storing.

WARNINGS & IMPORTANT SAFEGUARDS CONTINUED ON PAGE 2

LIMITED WARRANTY

Masterbuilt warrants its products to be free from defects in material and workmanship under proper assembly, normal use and recommended care for 90 days from the date of original retail purchase. Masterbuilt warranty does not cover paint finish as it may burn off during normal use. Masterbuilt warranty does not cover rust of the unit.

Masterbuilt requires reasonable proof of purchase for warranty claims and suggests that you keep your receipt. Upon the expiration of such warranty, all such liability shall terminate. Within the stated warranty period, Masterbuilt, at its discretion, shall repair or replace defective component free of charge with owner being responsible for shipping. Should Masterbuilt require return of component in question for inspection Masterbuilt will be responsible for shipping charges to return requested item. This warranty excludes property damage sustained due to misuse, abuse, accident, damage arising out of transportation, or damage incurred by commercial use of this product.

This expressed warranty is the sole warranty given by Masterbuilt and is in lieu of all other warranties, expressed or implied including implied warranty, merchantability, or fitness for a particular purpose. Neither Masterbuilt nor the retail establishment selling this product, has authority to make any warranties or to promise remedies in addition to or inconsistent with those stated above. Masterbuilt's maximum liability, in any event, shall not exceed the purchase price of the product paid by the original consumer/ purchaser. Some states do not allow the exclusion or limitation of incidental or consequential damages. In such a case, the above limitations or exclusions may not be applicable.

California residents only: Notwithstanding this limitation of warranty, the following specific restrictions apply; if service, repair, or replacement of the product is not commercially practical, the retailer selling the product or Masterbuilt will refund the purchase price paid for the product, less the amount directly attributable to use by the original buyer prior to the discovery of the nonconformity. Owner may take the product to the retail establishment selling this product in order to obtain performance under warranty. This expressed warranty gives you specific legal rights, and you may also have other rights which vary from state to state.



Go Online www.masterbuilt.com
or complete and return to
Attn: Warranty Registration
Masterbuilt Mfg. Inc.
1 Masterbuilt Court - Columbus, GA 31907

Name: _____ Address: _____ City: _____

State/Province: _____ Postal Code: _____ Phone Number: (____) - _____

E-mail Address: _____

*Model Number: _____ *Serial Number: _____

Purchase Date: ____ - ____ - ____ Place of Purchase: _____

*Model Number and Serial Number are located on silver label on back of unit.

RECIPES

HERB-MUSTARD CHICKEN QUARTERS

2 tbsp creamy Dijon-style mustard blend
1 tbsp snipped fresh parsley
1 tbsp snipped fresh oregano or 1 tsp dried oregano crushed
1 tbsp water
1/8 tsp ground red pepper

3 to 3 1/2 lb whole broiler-fryer chicken, cut into quarters

For sauce, in a small bowl combine mustard, parsley, oregano, water and red pepper. Cover and chill until ready to use. Optional to remove skin.

Place chicken bone side down. Cover and grill for 50-60 minutes or until chicken is no longer pink. (170° F degrees for breast and 180° F degrees for dark meat). Brush the pieces with sauce occasionally during the last 10 minutes of grilling.

CAJUN HALIBUT

Relish
1 can (7 oz) Green Giant Niblets whole kernel corn,
drained
1 medium tomato, chopped
2 medium green onions, chopped (2 tbsp)
1 tablespoon cider vinegar
2 tsp honey
1/4 tsp dried oregano leaves
1/4 tsp ground red pepper (cayenne)
1/4 tsp salt

Fish
4 halibut steaks (about 6 oz each)
2 tbsp Worcestershire sauce
1/2 tsp coarse ground pepper

1/4 tsp dried oregano leaves

In small bowl, mix all relish ingredients; set aside. Brush halibut with Worcestershire sauce; sprinkle with pepper and oregano. Cover and grill fish over medium heat 10-15 minutes, turning once or twice, until fish flakes easily with fork. Serve fish with relish.



GENERAL WARNINGS AND SAFETY INFORMATION



- Be careful when removing food from electric grill. All surfaces are HOT and may cause burns. Use protective gloves or long, sturdy cooking tools.
- Drip tray is only for the bottom of electric grill. Do not put drip tray on cooking grate this may damage electric grill.
- To disconnect, turn control panel "OFF" then remove plug from outlet.
- Unplug from outlet when not in use and before cleaning. Allow unit to cool completely before adding/removing grate, or drip tray.
- Dispose of cold ashes by placing them in aluminum foil, soaking with water and discarding in a non-combustible container.
- Do not store electric grill with HOT ashes inside unit. Store only when all surfaces are cold.
- Accessory attachments not supplied by Masterbuilt Manufacturing, Inc. are not recommended and may cause injury.
- The use of accessory attachments not recommended by the appliance manufacturer may cause injuries.
- Never use electric grill for anything other than its intended purpose. This unit is not for commercial use.
- Always use electric grill in accordance with all applicable local, state and federal fire codes.
- Longer detachable power-supply cords or extension cords are available and may be used if care is exercised in their use.
- If a longer detachable power-supply cord or extension cord is used: 1. The marked electrical rating of the cord set or extension cord should be at least as great as the electrical rating of the appliance; and 2. The cord should be arranged so that it will not drape over the counter top or tabletop where it can be pulled by children or tripped over intentionally.
- The extension cord must be a grounding -type 3-wire cord.
- Outdoor extension cords must be used with outdoor use products and are marked with suffix "W" and with the statement "Suitable for Use with Outdoor Appliances.
- CAUTION - To reduce the risk of electric shock, keep extension cord connection dry and off the ground.
- Do not clean this product with a water sprayer or the like.
- Keep hands, hair and face away from the element. Be careful of loose hair and clothing during operation, they could catch fire.
- Never use glassware, plastic or ceramic cookware on this grill.
- Preheating grill is not necessary. If preheating is desired, open lid with caution.
- Minimum distance from side and back of appliance to walls or railing is 24 inches.
- Do not use unit near heat sensitive or combustible structures such as vinyl or wood siding.

WARNINGS & IMPORTANT SAFEGUARDS CONTINUED ON PAGE 3

GENERAL WARNINGS AND SAFETY INFORMATION

- Fatty foods (hamburgers, etc.) can have excess grease and cause flare ups. When cooking fatty foods use a low setting with lid open.
- Clean internal base pan before each use. This will cut down on build-up and flare-ups.
- Do not expose electric grill to rain. Do not use around water or operate on wet surfaces. This could cause an electric shock leading to injury and death.
- Be sure drip tray is clean before each use.

SAVE THESE INSTRUCTIONS

WARNING

COMBUSTION BY-PRODUCT PRODUCED WHEN USING THIS PRODUCT CONTAINS CHEMICALS KNOWN TO THE STATE OF CALIFORNIA TO CAUSE BIRTH DEFECTS, OTHER REPRODUCTIVE HARM, OR CANCER.

THE MATERIALS USED IN THIS PRODUCT MAY CONTAIN LEAD A CHEMICAL KNOWN TO THE STATE OF CALIFORNIA TO CAUSE BIRTH DEFECTS AND OTHER REPRODUCTIVE HARM.

RECIPES

BBQ BURGERS

- ¼ cup catsup
- 2 tbsp steak sauce
- 1 tbsp water
- 1 tsp sugar
- 1 tsp vinegar
- 1 clove garlic, minced
- 1 lb lean ground beef
- ¼ tsp salt
- ¼ tsp black pepper

4 hamburger buns, split and toasted

For sauce, in small saucepan combine catsup, steak sauce, water, sugar, vinegar, garlic, and if desired, hot pepper sauce. Bring to boiling, and reduce heat. In a medium bowl combine ground beef, salt, and pepper. Shape meat mixture into four ¼ inch thick patties.

Grill patties on the rack of an uncovered grill directly over medium coals for 14-18 minutes or until meat reaches 160° F degrees internally. Turn patties once during cooking and brush once or twice with sauce during the last five minutes. Serve burgers on buns.

Optional: few dashes bottled hot pepper sauce, American cheese slices, lettuce leaves, tomato slices, onion slices, and pickle slices.

TANGY PEANUT-SAUCE RIBS

- 4 lbs meaty pork spareribs or pork loin back ribs
- ¼ cup hot water
- ¼ cup peanut butter
- 2 tbsp lime juice
- 2 tbsp sliced green onion
- ½ tsp grated fresh ginger or ¼ tsp ground ginger

¼ tsp ground red pepper

Trim fat from ribs. Cut ribs into 4-6 serving size pieces. Place ribs bone side down. Cover and grill for 1 to 1 ¼ hours or until tender. Meanwhile, for sauce, in a small saucepan gradually stir hot water into peanut butter (mixture will stiffen at first). Stir in lime juice, green onion, ginger, and red pepper. Cook and stir over low heat until heated through. Spoon sauce over ribs.

SAFE STORAGE AND MAINTENANCE

- Inspect hardware and assembled parts on a regular basis to insure grill is in safe working condition.
- ALWAYS allow grill to cool completely before handling.
- ALWAYS empty drip tray after use only when ashes have completely cooled.
- Clean grill, including special surfaces such as cooking grates with mild cleaning agents. Wipe outside of grill with damp rag. DO NOT use oven cleaner.
- ALWAYS cover and store cold grill in a protected area.
- Indoor storage of grill is permissible only if the grill is completely cold. Remember to clean drip tray before storing.
- Grill is made of steel and may rust over time. If rusting occurs on outside surfaces, clean area with sand paper or steel wool, then cover with heat resistant paint, except for stainless steel parts.
- If rusting occurs on the inside surface of grill, clean area with sandpaper or steel wool, then coat with cooking oil, except for stainless steel parts.
- NEVER USE PAINT ON INSIDE SURFACES OF GRILL.

ALWAYS MAKE SURE UNIT IS UNPLUGGED AND COOL TO THE TOUCH BEFORE CLEANING AND STORING.

REMINDER: NEVER OPERATE THIS GRILL UNDER ANY OVERHEAD CONSTRUCTION. MAINTAIN A MINIMUM DISTANCE OF 10 FT (3M) FROM OVERHEAD CONSTRUCTION, WALLS OR RAILS. SEE DIAGRAM BELOW.

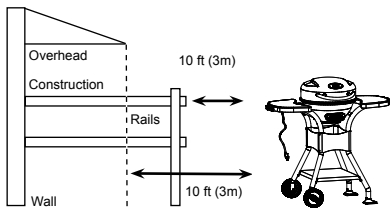

DO NOT RETURN TO RETAILER For Assembly Assistance, Missing or Damaged Parts
Call: MASTERBUILT Customer Service at 1-800-489-1581.
Please have Model Number and Serial Number available when calling.
These numbers are located on silver label on back of unit.

PARTS LIST

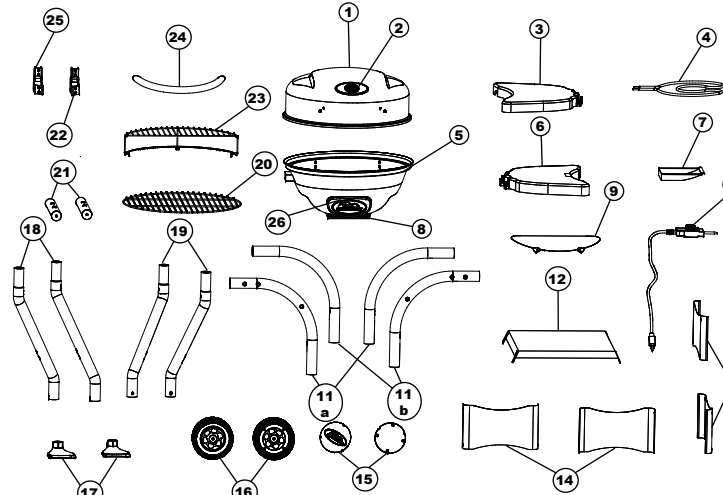

PART NO	QTY	DESCRIPTION	PART NO	QTY	DESCRIPTION
1	1	Grill Lid	14	2	Front/Back Panel
2	1	Temperature Gauge	15	2	Hub Cap
3	1	Right Side Shelf	16	2	Wheel
4	1	Heating Element	17	2	Foot
5	1	Grill Base	18*	2	Leg
6	1	Left Side Shelf	19*	2	Wheel Leg
7	1	Drip Tray	20	1	Cooking Grate
8	1	Drip Tray Bracket	21	2	Seat
9	1	Reflector Plate	22	2	Right Hinge
10	1	Controller	23	1	Warming Rack
11a	2	Front right/Back left Leg	24	1	Handle
11b	2	Front left/Back right Leg	25	2	Left Hinge
12	1	Bottom Shelf	26	1	Logo Base
13	2	Side Panel			

*Legs are marked with stickers (FR-Front Right, FL-Front Left, BR-Back Right, BL-Back Left) to correspond easily with parts 11a and 11b during assembly Steps 3-5.

HARDWARE LIST

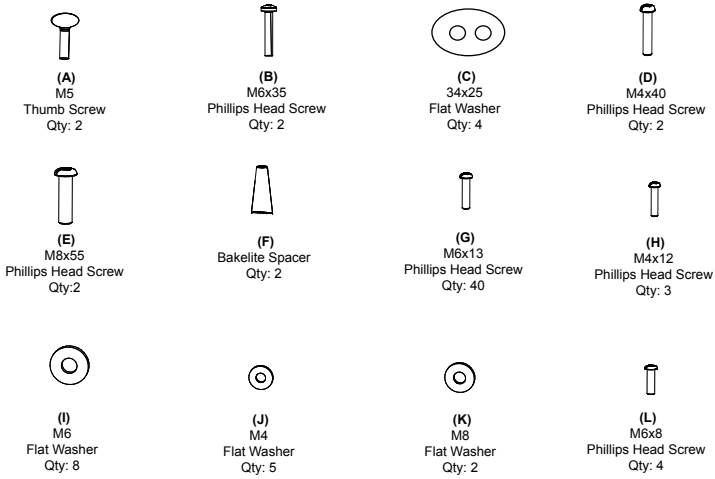

PARTS LIST

PART NO	REPLACEMENT PART	PART NO	REPLACEMENT PART
9915110002	Lid Kit - Blue	9915110016	Rear Left Leg Kit
9915110003	Base Kit	9915110017	Rear Right Leg Kit
9915110004	Lid Handle Kit	9915110018	Front Panel Kit
9915110005	Hinge Kit	9915110019	Back Panel Kit
9915110006	Right Side Shelf Kit	9915110020	Side Panel Kit
9915110007	Left Side Shelf Kit	9915110021	Bottom Shelf Kit
9915110008	Logo Plate Kit	9915110022	Wheel Kit
9915110009	Temperature Gauge Kit	9910090010	Element Kit
9915110010	Drip Pan Kit	9015110002	Foot
9915110011	Leg Brace Kit	9015110003	Warming Rack
9915110012	Front Left/Back Right Leg Kit	9015110004	Cooking Grate
9915110013	Front Right/Back Left Leg Kit	9015110005	Reflector Plate
9915110014	Front Left Leg Kit	9015110001	Grill Cover
9915110015	Front Right Leg Kit	9007090063	Analog Control w/ Power Cord
9015110006	Hub Cap	9915110001	Hardware Kit
		9815110001	Instruction Manual



DO NOT RETURN TO RETAILER For Assembly Assistance, Missing or Damaged Parts
 Call: MASTERBUILT Customer Service at 1-800-489-1581.
 Please have Model Number and Serial Number available when calling.
 These numbers are located on silver label on back of unit.

ASSEMBLY

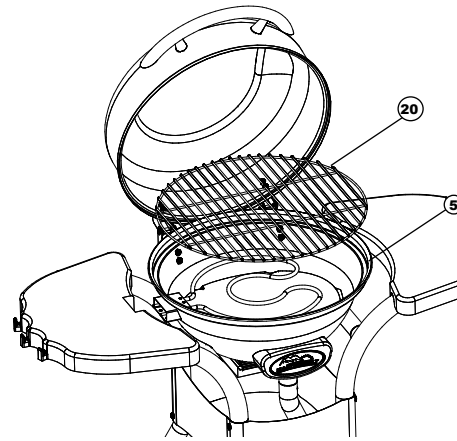

STEP 17

Position cooking grate (20) on top of grill base (5).

STEP 18

Insert warming rack (23) into grill base (5).

Insert controller (10) into side of grill base (5).

Slide drip tray (7) onto drip tray bracket (8).

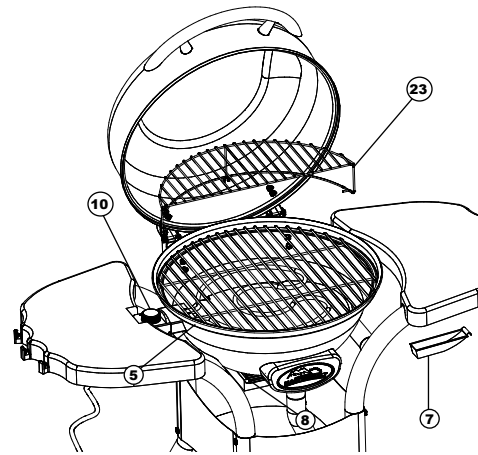

ASSEMBLY IS COMPLETE

ASSEMBLY

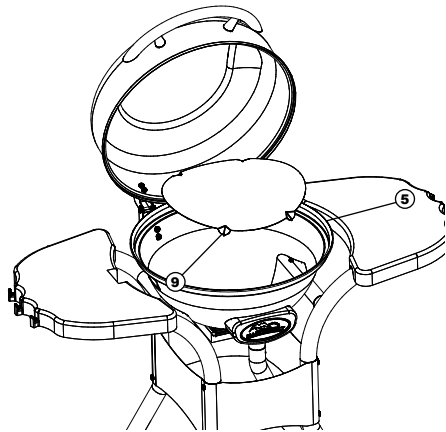

STEP 15
Place reflector plate (9) into bottom of grill base (5).

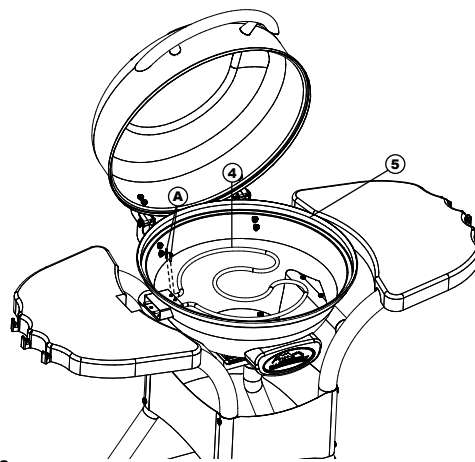

STEP 16
Attach heating element (4) to grill base (5) using screws (A) as shown.

ASSEMBLY

- BEFORE ASSEMBLY READ ALL INSTRUCTIONS CAREFULLY.
- ASSEMBLE UNIT ON A CLEAN, FLAT SURFACE.
- TOOL NEEDED: PHILLIPS HEAD SCREWDRIVER

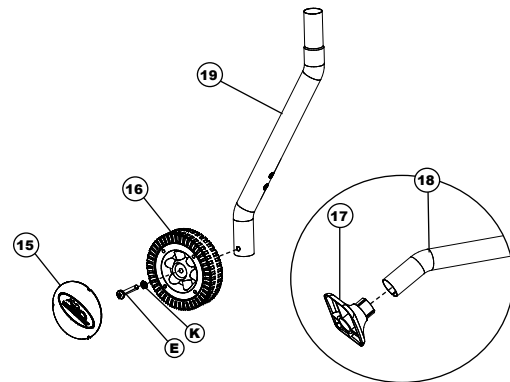

STEP 1a
Attach wheel (16) to wheel leg (19) using washer (K) and screw (E) as shown.

Snap hubcap (15) onto wheel.

STEP 1b
Align ribs on bottom of foot (17) with leg (18). Push foot (17) into bottom of leg.

Repeat step for remaining legs.

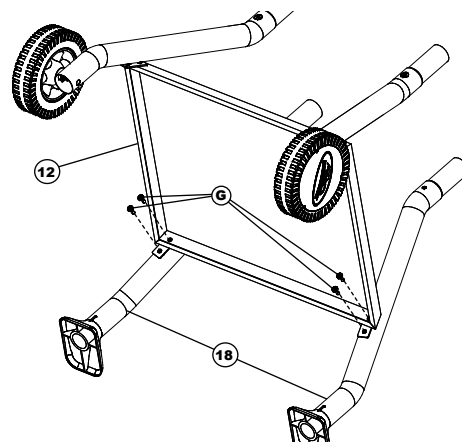

STEP 2
Attach bottom shelf (12) to legs (18) using screws (G).

Repeat step on opposite side for wheel legs.

ASSEMBLY

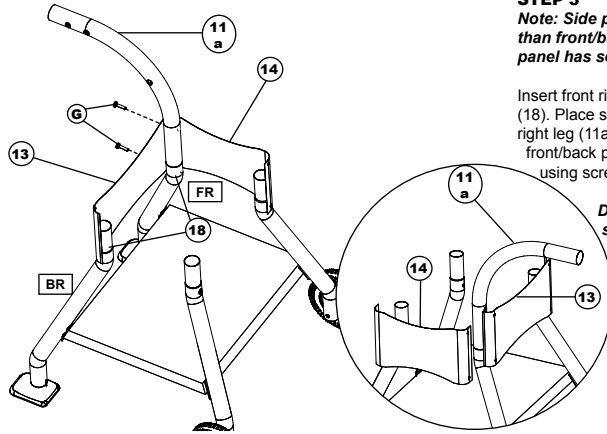

STEP 3
Note: Side panels are longer than front/back panels. Back panel has serial plate.

Insert front right leg (11a) onto leg* (18). Place side panel (13) on front right leg (11a) first. Overlap with front/back panel (14). Secure using screws (G) as shown.

Do not fully tighten screws.

**Legs are marked with stickers (FR-Front Right, FL-Front Left, BR-Back Right, BL-Back Left) to correspond easily with parts 11a and 11b during assembly Steps 3-5.*

ASSEMBLY

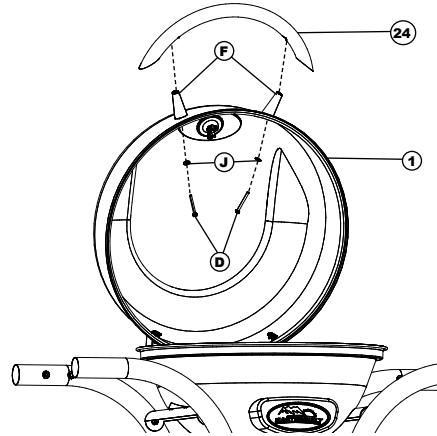

STEP 13
 Place bakelite spacer (F) on grill lid (1). Attach handle (24) using washers (J) and screws (D) as shown.

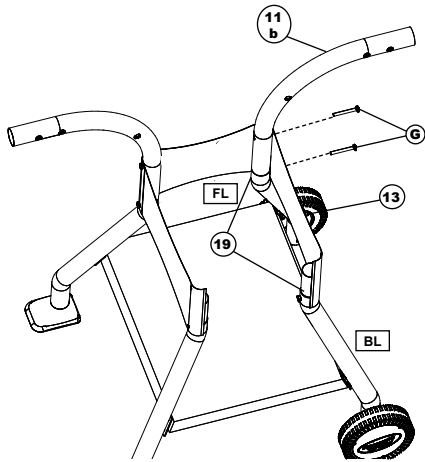

STEP 4
 Insert front left leg (11b) onto wheel leg (19). Place front/back panel (14) over side panel (13) over. Secure using screws (G).

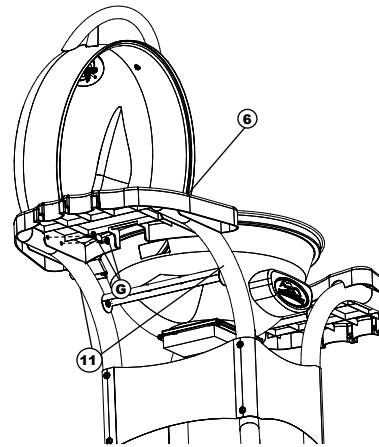

STEP 14
 Attach left side shelf (6) to both side shelf legs (11) using screws (G).

Repeat step on opposite side for right side shelf.

ASSEMBLY

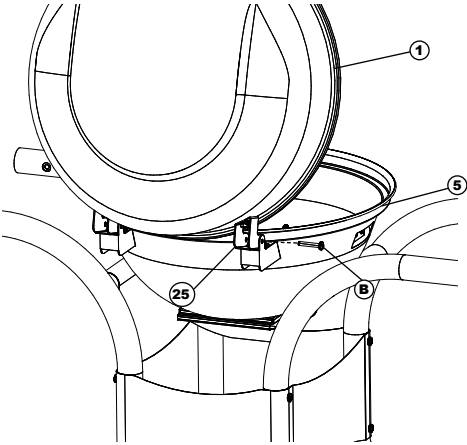

STEP 11
Position grill lid (1) on top of grill base (5) as shown. Secure hinges using screw (B).
Repeat step on opposite side.

ASSEMBLY

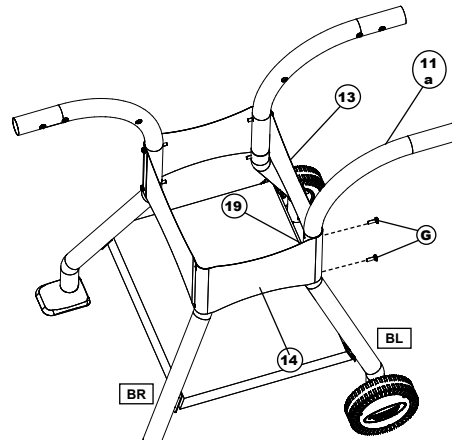

STEP 5
Insert back left leg (11a) onto wheel leg (19). Place front/back panel (14) over side panel (13). Secure using screws (G).
Insert remaining side shelf leg into long leg on opposite side and secure using screws (G).

STEP 12
Note: Wing nut is packaged with temperature gauge.
Attach temperature gauge base and temperature gauge (2) to grill lid (1) using wing nut.

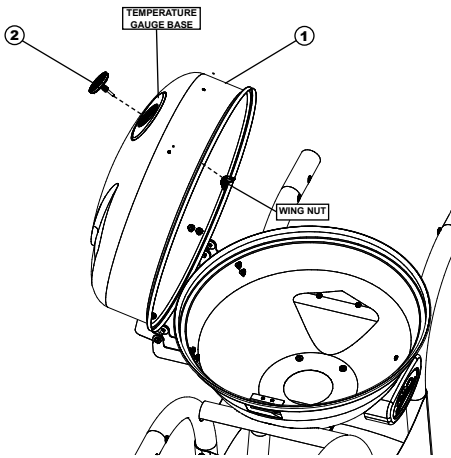

STEP 6
Attach seat (21) to back left leg (11a) using screws (G).
Repeat step for remaining seat on opposite end.

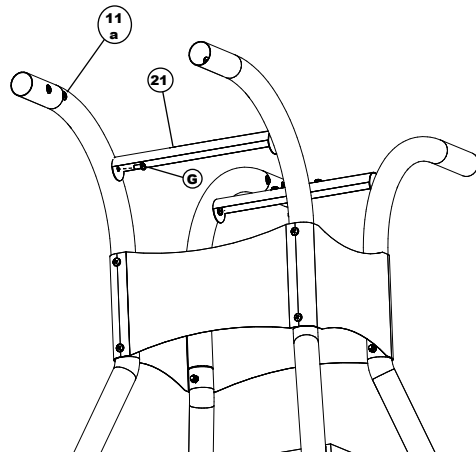

ASSEMBLY

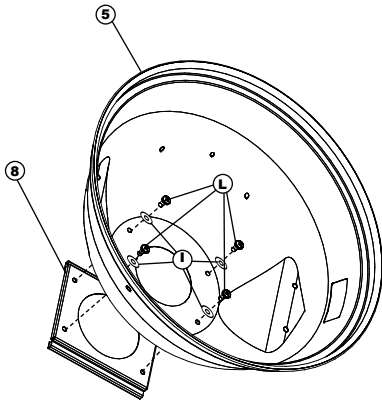

STEP 7
Attach drip tray bracket (8) to grill base (5) using washers (I) and screws (L).

ASSEMBLY

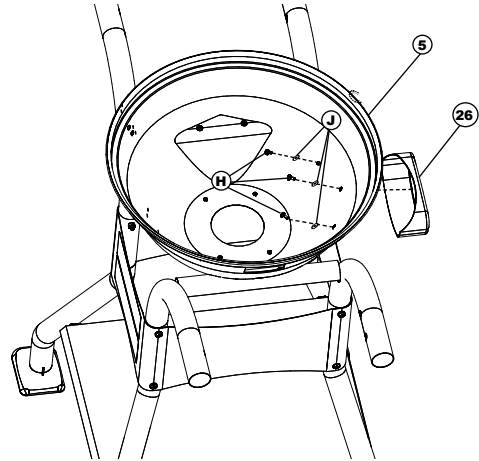

STEP 9
Place logo base (26) onto grill base (5). Secure using washers (J) and screws (H).

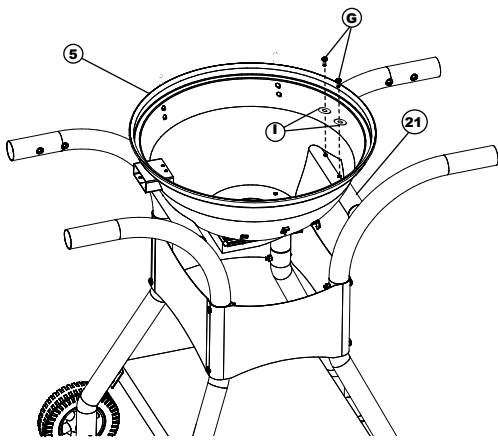

STEP 8
Position grill base (5) onto seat (21) as shown. Secure using washers (I) and screws (G).
Repeat step on opposite side.

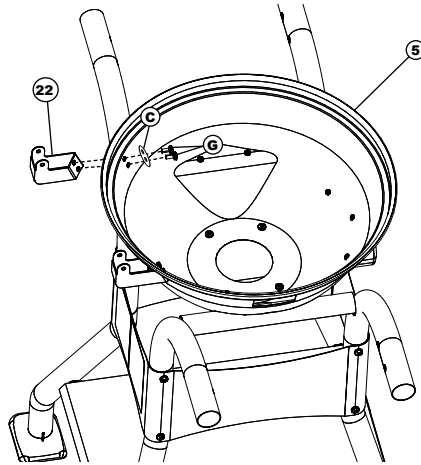

STEP 10
Note: Hinge for grill base is larger than hinge for grill lid.
Attach right hinge (22) to grill base (5) using washers (C) and screws (G) as shown.
Repeat step for grill lid (1).

