

Hybrid Grill

Infrared, Gas & Charcoal Cooking System

Models Number:

GR2071013-MM-00



ASSEMBLY & OPERATING INSTRUCTIONS

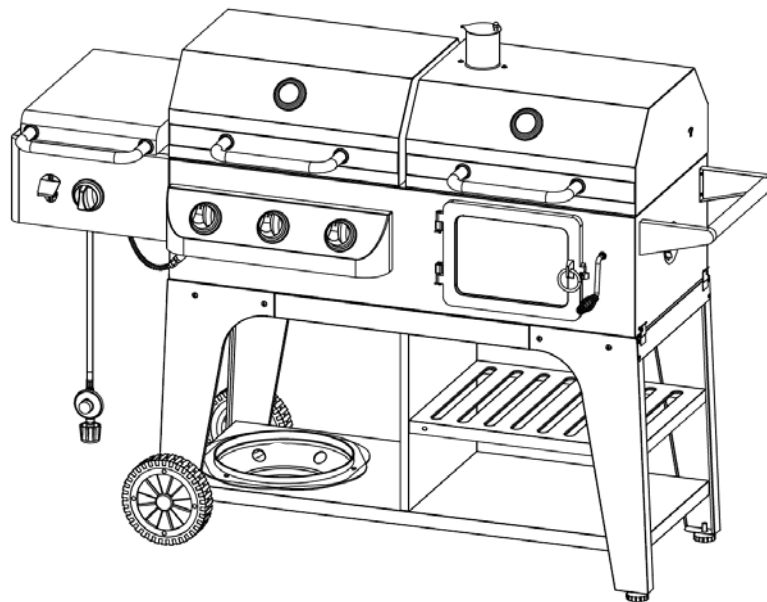

For Outdoor Use Only

- This instruction manual contains important information necessary for the proper assembly and safe use of the appliance.
- Read and follow all warnings and instructions before assembling/using the appliance.
- Follow all warnings and instructions when using the appliance.
- Keep this manual for further reference



ATTENTION



Please do not withdraw all parts from the packing boxes immediately!!

Each assembly step in this instruction manual has instructed you to find the particular part(s) from the packing box quickly. We strongly recommend that you read through the assembly procedure before proceeding assembly.

Should you encounter any problem,
CALL US FIRST.

DO NOT return product to the retail store!!

WE CAN HELP.

For assistance, contact customer service at customerservice@rankam.com
or at (888) 837-1380, Mon to Fri, 8:00am – 5:00pm Pacific Standard time



DANGER



If you smell gas:

1. Shut off gas to the appliance.
2. Extinguish any open flame.
3. Open lid.
4. If odor continues, keep away from the appliance and immediately call your gas supplier or fire department.

Failure to follow these instructions could result in fire or explosion which could cause property damage, personal injury or death.



WARNING



1. Do not store or use gasoline or other flammable liquids or vapors in the vicinity of this or any other appliance.
2. An LP cylinder not connected for use shall not be stored in the vicinity of this or any other appliance.



DANGER



- (a) Do not store a spare LP-gas cylinder under or near this appliance;
- (b) Never fill the cylinder beyond 80 percent full; and
- (c) If the information in (a) and (b) is not followed exactly, a fire causing death or serious injury may occur.





PROP 65 WARNING



Chemicals known to the State of California to cause cancer and birth defects or other reproductive harm are created by the combustion of propane, charcoal, or other wood products.

SAFETY LABELS

 **DANGER:** Indicates an imminently hazardous situation which, if not avoided, will result in death or serious injury.

 **WARNING:** Be alert to the possibility of serious bodily injury if the instructions are not followed. Be sure to read and carefully follow all of the messages.

 **CAUTION:** Indicates a potentially hazardous situation, which, if not avoided, may result in minor or moderate injury.

GAS GRILL GENERAL WARNINGS



WARNING



- This outdoor cooking gas appliance shall be used only outdoors and shall not be used in a building, garage or any other enclosed area.
- This outdoor cooking gas appliance is not intended to be installed in or on boats. This appliance is not intended to be installed in or on recreational vehicles.
- Use your grill **OUTDOORS** in a well ventilated space away from dwellings or other buildings to prevent dangers associated with gas accumulation and toxic vapors. The grill should be situated at least 60 inches (153 cm) from buildings. Not adhering to these clearances will prevent proper ventilation and may increase the risk of a fire and/or property damage, which could also result in personal injury.
- Maintain a minimum clearance of 60 inches (153 cm) between all sides of grill, deck railings, walls or other combustible material. **DO NOT** use grill under overhead combustible construction.
- **DO NOT** obstruct the flow of combustion/ventilation air.
- **DO NOT** leave the grill unattended while in use.
- **DO NOT** use while under the influence of drugs or alcohol.
- Keep the fuel supply hose away from heated surfaces.
- **DO NOT** put grill in storage or move it immediately after use. Allow grill to cool to touch before moving/storing. Failure to do so could result in fire resulting in property damage, personal injury or death.
- The appliance is for household use only. **DO NOT** use this grill for other than its intended purpose.
- Never use natural gas in a unit designed for liquid propane gas.
- Never use charcoal or wood briquettes in a gas grill. Flavoring chips must be contained in a metal smoking box to contain ash and prevent fires.
- Leak test must be conducted prior to each use.
- Keep a fire extinguisher on hand acceptable for use with gas products. Refer to your local authority to determine proper size and type.
- Grill is hot when in use. To avoid burns:
 - **DO NOT** attempt to move the grill.
 - Wear protective gloves or oven mitts.
 - **DO NOT** touch any hot grill surfaces.
 - **DO NOT** wear loose clothing or allow hair to come in contact with grill.
- Never close the **SIDE BURNER LID** during operation.

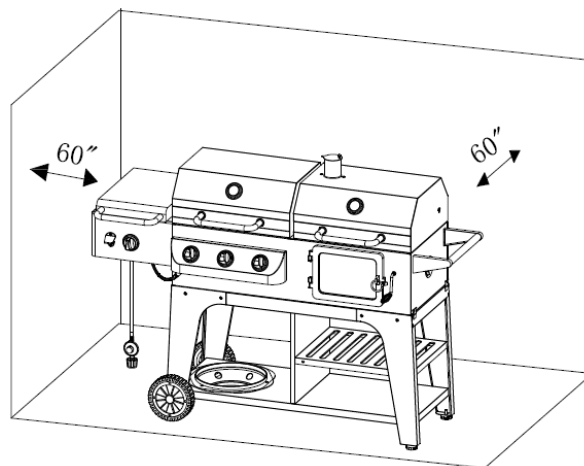

Maintain a minimum clearance of 60 in. from combustible material.

USE OF LP GAS CYLINDER AND INSTALLATION

BEFORE INSTALLING:

The installation must conform with local codes or, in the absence of local codes, with either the *National Fuel Gas Code, ANSI Z223.1/NFPA 54, Natural Gas and Propane Installation Code, CSA B149.1, or Propane Storage and Handling Code, B149.2,* or the *Standard for Recreational Vehicles, ANSI A 119.2/NFPA 1192, and CSA Z240 RV Series, Recreational Vehicle Code,* as applicable.

BEFORE EVERY USAGE:

Be sure to inspect the hose for leaks, cuts, wear, abrasion, or damage of any sort before using this appliance. If any damage is apparent the hose must be replaced with a replacement hose specified by the manufacturer before it is put in use.

LP GAS CYLINDER

The LP (liquid propane) cylinder specifically designed to be used with this unit **MUST** have a 20 lb. (9.1kg) capacity with a Type 1 cylinder valve and an overfilling protection device (OPD). Only use LP cylinders with this type of valve.

The nominal cylinder: Height = 18 inches (45.7 cm), Diameter = 12 inches (30.5cm) and bottom ring diameter = 8 inches (20.3 cm)

LP tank valve must have:

- Type 1 outlet compatible with regulator or appliance.
- Safety relief valve.
- UL listed Overfill Protection Device (OPD). This OPD safety feature is identified by a unique triangular hand wheel. Use only tanks equipped with this type of valve.
- LP tank must be arranged for vapor withdrawal.



The LP cylinder must be constructed and marked in accordance with the Specifications for LP-Gas Cylinders of the U.S. Department of Transportation (D.O.T.) or the National Standard of Canada CAN/CSA – B339, Cylinder, Spheres and Tubes for Transportation of Dangerous Goods; and Commission of Dangerous Goods; and Commission, as applicable.

- The LP cylinder must include a collar to protect the cylinder valve.
- The LP cylinder must be stored outdoors out of the reach of children and pets. It **SHALL NOT** be stored in a building, garage, shed, breezeway, or any other enclosed space.
- Storage of an outdoor cooking gas appliance indoors is permissible **ONLY** if the cylinder is disconnected and removed from the outdoor cooking gas appliance.
- The cylinder should **ALWAYS** be put in an upright position.

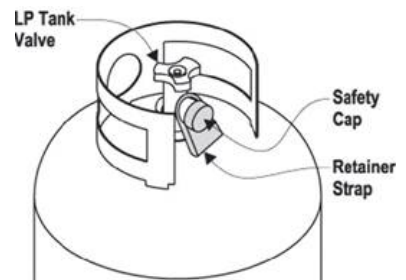



WARNING



Place dust cap on cylinder valve outlet whenever the cylinder is not in use. Only install the type of dust cap on the cylinder valve outlet that is provided with the cylinder valve. Other types of caps or plugs may result in leakage of propane.



DANGER



- DO NOT connect this grill to an existing #510 POL cylinder valve with Left hand threads. The Type 1 valve can be indentified with the large external threads on the valve outlet.
- DO NOT connect to a propane cylinder exceeding this capacity.
- DO NOT connect to a cylinder that uses any other type of valve connection device.
- Never store a spare LP gas cylinder under or near your grill. This could cause pressure to be expelled through the vapor relief valve resulting in fire, explosion, or severe personal injury including death.
- Keep the ventilation opening(s) of the LP gas cylinder enclosure free and clear from obstructions and debris.
- DO NOT insert any foreign objects into the valve outlet. Damage to the back-check could result. A damaged back-check can cause a leak, possibly resulting in explosions, fire, severe bodily harm, or death.
- Place dust cap on cylinder valve outlet whenever cylinder is not in use. Only install the type of dust cap on the cylinder valve outlet that is provided with the cylinder valve. Other types of caps or plugs may result in leakage of propane.



WARNING



FOR FILLING THE LP GAS CYLINDER

- Allow only qualified LP gas dealers to properly fill or repair your LP cylinder.
- DO NOT allow the cylinder to be filled beyond 80% capacity. Over-filled tanks can create a dangerous condition. Over-filled tanks can build-up pressure and cause the relief valve to expel propane gas vapors. The vapor is combustible and if it comes in contact with a spark source or flame an explosion causing severe burns, bodily harm, or death could occur.
- Always use a safety cap when grill is not connected to cylinder.
- If you exchange a cylinder with a qualified exchange program, be sure the cylinder has a Type 1 valve and an over-filling prevention device (OPD).

INSTALLING GAS CYLINDER

1. Check that cylinder valve is closed by turning knob clockwise.
2. Place cylinder to cylinder fixture which is at the bottom cart of the grill per picture shown.

WARNING: Keep the fuel supply hose away from any heated surfaces.

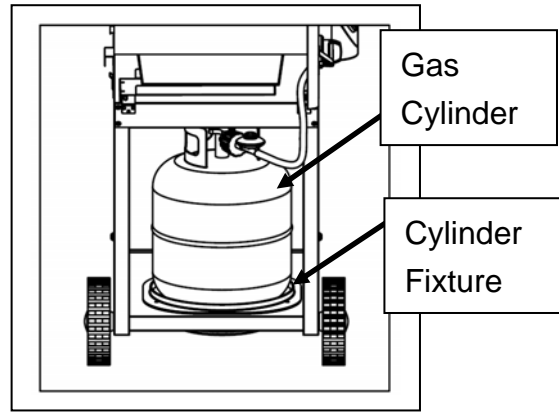

WARNING



- The pressure regulator and hose assembly supplied with your gas grill must be used. Replacement pressure regulators and hose assemblies must be those specified by the grill manufacturer.
- Do not attempt to connect it to any other fuel supply source.
- Do not attempt to adjust or repair the regulator. The regulator is designed to operate at the maximum output pressure of 11 inches of water column (2.74 kPa).

CONNECTION PROCEDURES

1. Make sure the tank valve is closed (turn valve clockwise till tight)
2. Check tank valve to insure it has proper external male threads.
3. Make sure all burner valves are **OFF**.
4. Inspect valve connections, port, and regulator assembly. Look for any damage or debris. Remove any debris. Inspect hose for damage. Never attempt to use damaged or obstructed equipment. See local L.P gas dealer for repair.
5. When connecting regulator assembly to the valve, hand tighten the quick coupling nut clockwise to a complete stop. Do not use a wrench to tighten. Use of a wrench may damage the quick coupling nut and result in a hazardous condition.
6. Open the tank valve fully (counterclockwise). Use a soapy water solution to check all connections for leaks before attempting to light the grill (see below). If a leak is found, turn the tank valve off and do not use the grill until a local LP gas dealer can make repairs.

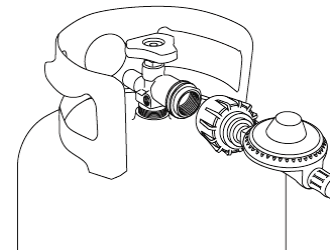

To disconnect LP gas cylinder:





WARNING



- If the grill is not in use, the gas must be turned off at the supply cylinder(s). Storage of the grill is permissible only if the cylinder is disconnected and removed from the grill.
- Cylinders must be stored outdoors out of the reach of children and pets and must not be stored in a building, garage or any other enclosed area.

1. Turn the burner valves off.
2. Turn the tank valve off fully (turn clockwise to stop).
3. Detach the regulator assembly from the tank valve by turning the quick coupling nut counterclockwise.

LEAK TEST

	WARNING	
<ul style="list-style-type: none"> ● DO NOT SMOKE WHILE CONDUCTING LEAK TEST. ● NEVER PERFORM LEAK TEST WITH AN OPEN FLAME. ● Perform test OUTDOORS only in a well ventilated area. ● If it is evident there is excessive abrasion or wear, or the hose is cut, it must be replaced prior to the appliance being operational. The replacement hose shall be specified the by manufacturer. <p>When to perform a leak test:</p> <ul style="list-style-type: none"> ● After assembling the grill and before lighting for the first time, even if purchased fully assembled. ● Every time the LP gas cylinder is refilled or if any of the gas components are replaced. 		

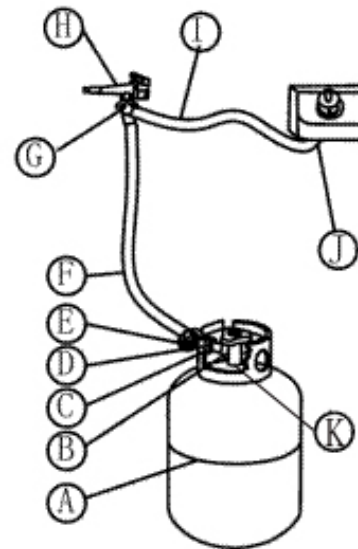

Checking for leaks:

1. Create a mixture of 50% water and 50% liquid dishwashing soap.
2. Open the lid.
3. Ensure all control knobs are set to the “OFF” position.
4. Turn on the fuel supply at the cylinder valve. Turn the cylinder valve knob one turn counter-clockwise.
5. Apply the soap water mixture to the following:
 - a. Supply tank weld.
 - b. Connection nut to tank valve.
 - c. Back side of connection nut to brass nipple.
 - d. Brass nipple connection into regulator.
 - e. Regulator connections to gas supply hoses.
 - f. Gas supply hose connection.
 - g. Side burner valve stem cap
 - h. Side burner connection to hose.
 - i. Stainless Steel Flexible Gas Tube.
 - j. The full length of gas supply hose.
 - k. Tank valve to cylinder.
6. Check each place (a-k) for growing bubbles which indicates a leak.
7. Turn off gas supply at cylinder valve.
8. Turn on control knobs to release gas pressure in hose.
9. Turn control knobs to “OFF” position.
10. Tighten any leaking connections.
11. Repeat soapy water test until no leaks are detected.
12. Turn off gas supply at cylinder valve until you are ready to use your grill.



LIGHTING INSTRUCTIONS

BEFORE LIGHTING

	<h1>WARNING</h1>	
<ul style="list-style-type: none">● Inspect the gas supply hose prior to turning the gas “ON”.● If there is evidence of cuts, wear, or abrasion, it must be replaced prior to use.● Do not use the grill if the odor of gas is present.● Only the pressure regulator and hose assembly supplied with the unit should be used.● Perform the “LEAK TEST” according to instruction before operating the grill.● ALWAYS keep your face and body as far away from the burner as possible while lighting.		

LIGHTING THE MAIN BURNER OF GRILL

1. Read all instructions before lighting.

2. Open lid during lighting.

3. Light the IGNITION BURNER first. Push and turn main burner knob slowly to HI. Burner should light immediately.

Light this burner first! Turn counterclockwise to open

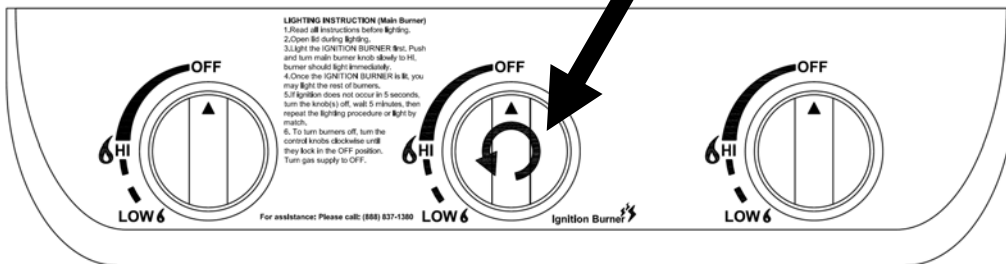

4. Once the IGNITION BURNER is lit, you may light the rest of burners.

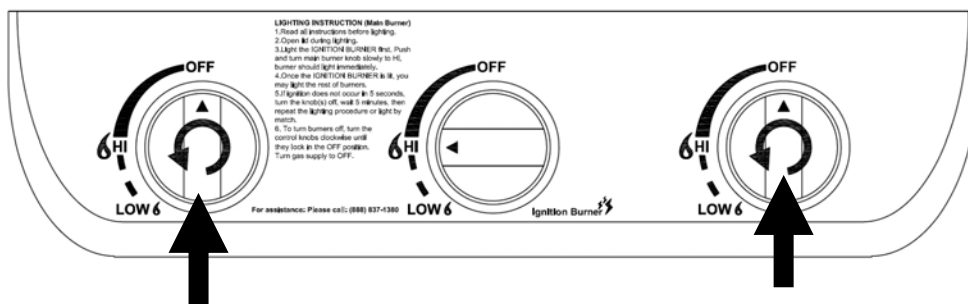

5. If ignition does not occur in 5 seconds, turn the knob(s) off, wait 5 minutes, then repeat the lighting procedure or light by match.

6. To turn burners off, turn the control knobs clockwise until they lock in the OFF position. Turn gas supply to OFF.

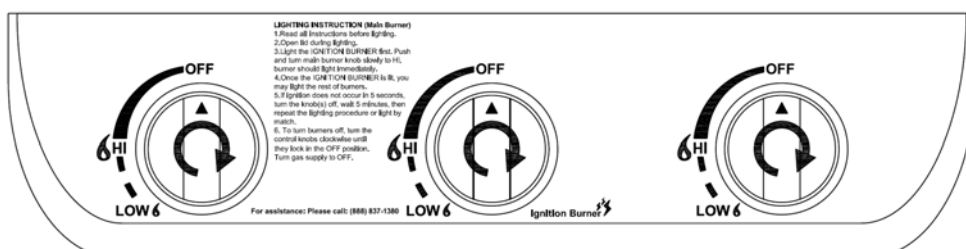

LIGHTING THE SIDE BURNER (Side burner):



DANGER



Never close the SIDE BURNER LID during operation

1. Read all instructions before lighting.
2. Open lid during lighting.
3. Push and turn main burner knob slowly to HI. The side burner should light immediately.
4. If ignition does not occur in 5 seconds, turn the knob off, wait 5 minutes, then repeat the lighting procedure or light by match.
5. To turn burners off, turn the control knob clockwise until it locks in the OFF position. Turn gas supply to OFF.

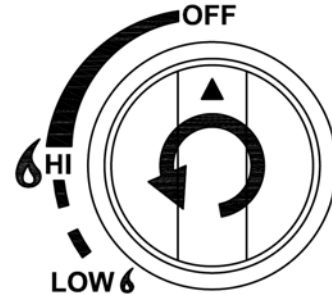

MATCH LIGHTING THE MAIN BURNERS:

1. Turn **OFF** all burner valves.
2. Make sure the lid is open.
3. Place a lighted match between the coils on the extension rod and hold next to the burner.
4. Turn the control knob(s) to the "HI" position. Burner should light immediately.
5. If the burner does not light in 4 seconds turn the knob off, wait 5 minutes and repeat above procedures.

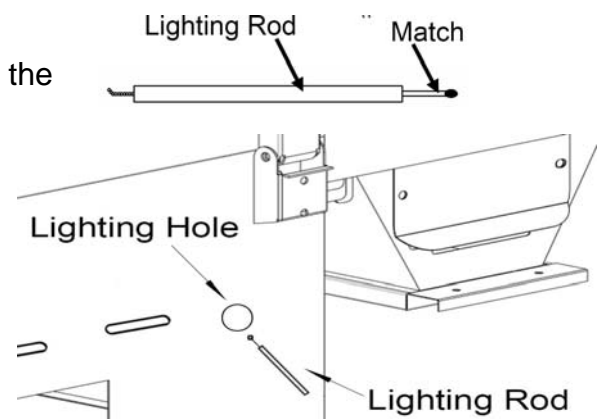

MATCH LIGHTING THE SIDE BURNER:

1. Turn **OFF** all burner valves.
2. Make sure the lid is open.
3. Strike and carefully place a long match 1/2" (1 to 2 cm) from the side burner
4. Turn the control knob to the "HI" position. Burner should light immediately.
5. If the burner does not light in 4 seconds turn the knob off, wait 5 minutes and repeat above procedures.

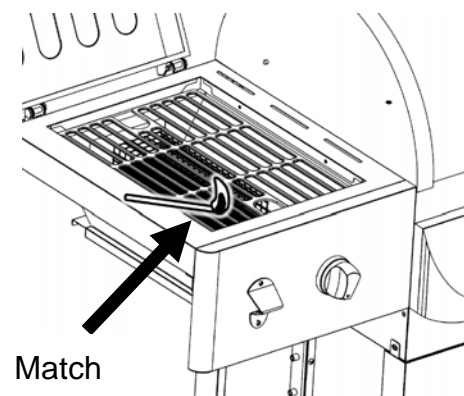

Infrared Side Burner Usage Tips

Infrared burners are commonly used in steak restaurants and they can quickly cook steaks or other thick meats. The infrared radiation generated by the burner immediately sears the outside of meat, locking in the moisture and giving the meat a charcoal-like taste.

Start your grill up

Turn on the gas at the tank and then the infrared burner. The infrared burner will heat up in around three minutes.

Place the steak on the cooking grate

The best is thick cuts of meat like steaks and pork chops when you use an infrared burner. Start by searing for one minute, then flip the meat and sear the other side. Infrared burners reach extremely high temperatures and therefore, thinner cuts of meat and delicate foods such as fish and vegetables are not recommended.

Finishing

There are 2 ways to cook meats to desired doneness. Leave the meat on the infrared burner, flipping it every 30 seconds to one minute until it's done. The whole process will not take over 4 to 5 minutes to cook. Or, you can move the seared meat to the non-infrared side of the grill and finish it off the traditional way. It takes double time but is easier to handle with this method.

Remove the meat

Remove the meat from the grill and cut thorough it to make sure all is cooked. Then turn off the grill to let it cool down.

	DANGER	
<ul style="list-style-type: none">● Keep your face and hands as far away from the grill as possible when lighting it.		

FLAME CHARACTERISTICS

This procedure outlines how to check for proper burner flame characteristics.

Burner flames should be blue and stable with little yellow tips, with no excessive noise, or lifting. If the flame is yellow, it indicates insufficient air. If the flame is noisy and tends to lift away from the burner, it indicates too much air. If any of these conditions exist call our customer service line.

Visually check the burner flames prior to each use. The flames should look like this picture. If they do not, refer to the cleaning burners and side burner of this manual.

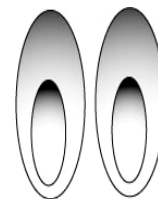

MAINTENANCE GUIDE

Before cleaning the grill, place it in an area clear and free from combustible materials, gasoline and other flammable vapors and liquids.

Do not obstruct the flow of combustion and ventilation air.

GREASE TRAY

The grease tray should be emptied and wiped down periodically and washed with a mild detergent and warm water solution. A small amount of sand or cat litter may be placed in the bottom of grease tray to absorb the grease. Check the grease tray frequently. Don't allow excess grease to accumulate in the grease tray. Accumulated grease will easily ignite. Therefore, it is important to clean and remove grease after each use.

GRILL BURNERS

Extreme care should be taken when removing a burner as it must be correctly centered on the orifice before any attempt is made to re-light the grill. Frequency of cleaning will depend on how often you use the grill.

Spiders and small insects occasionally spin webs or make nests in the grill burner tubes during transit and warehousing. These webs can lead to gas flow obstruction which could result in a fire in and around burner tubes. This type of fire is known as flashback and can cause serious damage to your grill and create an unsafe operating condition for the user.

Although an obstructed burner tube is not the only cause of flashback, it is the most common cause. To reduce the chance of flashback, you must clean the burner tubes before assembling your grill, and at least once a month in late summer or early fall when spiders are most active. Also, perform this burner tube cleaning procedure if your grill has not been used for an extended period of time.

You should inspect the burners at least once a year or immediately after any of the following conditions occur:

1. The smell of gas in conjunction with the burner flames appearing yellow.
2. The grill does not reach temperature.
3. The grill heats unevenly.
4. The burners make popping noises.

	<h1>WARNING</h1>	
<ul style="list-style-type: none">● ENSURE that the gas supply and the knobs are in the "OFF" position.		

Cleaning The Burner Tubes and Burner Ports (For main burners)

To reduce the chance of **FLASHBACK FIRE** you must clean the Burner Tubes as follows at least once a month in summer and fall or whenever spiders are active in your area, and if your grill has not been used for an extended period of time.

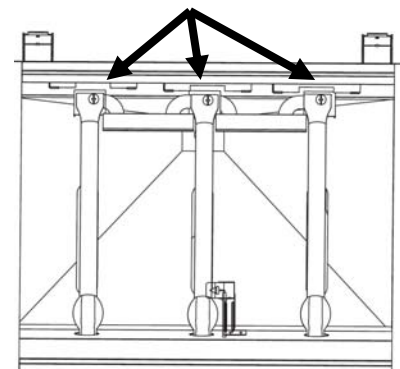

Removing the main burner(s):

1. Turn all Burner Valves to the full OFF position.
2. Turn the LP Gas tank valve to the full OFF position.
3. Detach the LP Gas regulator assembly from your gas cylinder.
4. Remove the Cooking Grates and Heat Distribution Plates from your grill.
5. Remove the screw from the front of each Burner using a Phillips Head Screwdriver.
6. Carefully lift each Burner up and away from the Gas Valve Orifice.
7. Check and clean burner/ venturi tubes for insects and insect nests. A clogged tube can lead to a fire beneath the grill.
8. Bend a stiff wire or wire coat hanger into a small hook as shown and run the hook through the Burner Tube and inside the Burner several times to remove debris.

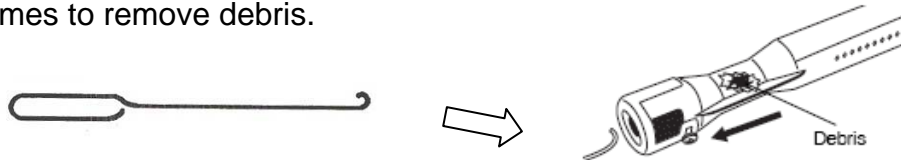

	<h1>WARNING</h1>	
<p>For safe operation ensure the Gas Valve Assembly Orifice is inside the Burner Tube before using your grill. See figure. If the Orifice is not inside the Burner Tube, lighting the Burner may cause explosion and/ or fire resulting in serious bodily injury and/or property damage.</p>		

When an appliance is supplied on casters and is connected to the supply piping by means of a connector for movable appliances, the operator shall be aware there is a restraint on the appliance and, if disconnection of the restraint is necessary, to reconnect this restraint after the appliance has been returned to its originally installed position.

Cleaning the Infrared side burner

1. Turn all Burner Valves to the full OFF position.
2. Turn the LP Gas tank valve to the full OFF position.
3. Detach the LP Gas regulator assembly from your gas cylinder.
4. Remove the Cooking Grates from the side burner.
5. Remove the mounting screws at the back of side burner.
6. Slide the infrared burner out of the enclosure.
7. Check and clean burner/ venturi tubes for insects and insect nests. A clogged tube can lead to a fire beneath the grill.
8. Bend a stiff wire or wire coat hanger into a small hook as shown and run the hook through the Burner Tube and inside the Burner several times to remove debris.

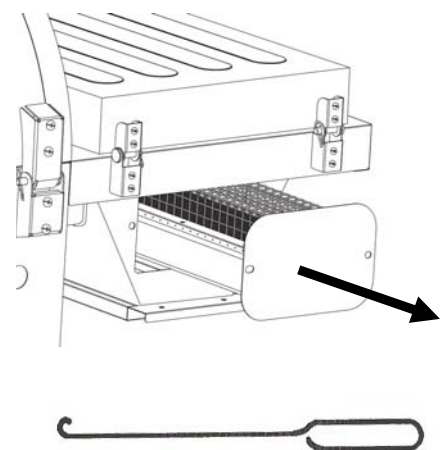



WARNING



For safe operation ensure the Gas Valve Assembly Orifice is inside the Burner Tube before using your grill. See figure. If the Orifice is not inside the Burner Tube, lighting the Burner may cause explosion and/ or fire resulting in serious bodily injury and/or property damage.

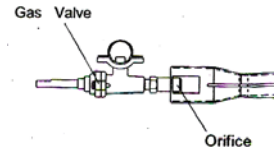

CAUTION



- Keep outdoor cooking gas appliance area clear and free from combustible materials, gasoline and other flammable vapors and liquids.
- Do not obstruct the flow of combustible and ventilation air.
- Keep the ventilation openings of the cylinder enclosure free and clear of debris.
- Check and clean burner/venturi tubes for insects and insect nests. A clogged tube can lead to a fire beneath the grill.

Clean the Grill

Clean grill often, preferably after each cookout. If a bristle brush is used to clean any of the grill cooking surfaces, ensure no loose bristles remain on cooking surfaces prior to grilling. It is not recommended to clean cooking surfaces while grill is hot.

CHARCOAL GRILL GENERAL WARNINGS



WARNING



- The maximum weight of charcoal to be used is 3.3lb (1.5kg). Too much charcoal may cause the gas component to over heat and malfunction.
- The charcoal chamber is for charcoal cooking only. Gas grill and side burner cannot be used for charcoal cooking.
- Only use this grill on a hard, level, non-combustible, stable surface (concrete, ground etc.) capable of supporting the weight of the grill. Never use on wooden or other surface that could burn.
- DO NOT use grill without charcoal ash tray in place. DO NOT attempt to remove charcoal ash tray while tray contains hot coals.
- Use your grill OUTDOORS in a well ventilated space away from dwellings or other buildings to prevent dangers associated with gas accumulation and toxic vapors. The grill should be situated at least 60 inches (153cm) from buildings. Not adhering to these clearances will prevent proper ventilation and may increase the risk of a fire and/or property damage, which could also result in personal injury.
- Maintain a minimum clearance of 60 inches (153 cm) between all sides of grill,

deck railings, walls or other combustible material. DO NOT use grill under overhead unprotected combustible construction.

- For outdoor use only. Do not use this grill for other than its intended purpose.
- For household use only. Do not use this grill for other than its intended purpose.
- We recommend the use of a Charcoal Chimney Starter to avoid the dangers associated with charcoal lighting fluid.
- Use charcoal chimney starter or charcoal that has been pre-treated with lighter fluid when starting fire in charcoal section of your grill.
- Do not store lighter fluid or other flammable liquids, material or charcoal that has been pre-treated with lighter fluid under the grill or inside storage shelves.
- Do not use gasoline or alcohol for lighting charcoal. Use of any of these or similar products could cause an explosion possibly leading to severe bodily injury.
- Never add charcoal lighting fluid to hot or even warm coals as flashback may occur causing severe burns.
- Place grill in an area where children and pets cannot come into contact with unit. Close supervision is necessary when grill is in use.
- Do not leave grill unattended when in use.
- When adding charcoal and/or wood, use extreme caution and follow instruction in Adding Charcoal / Wood during cooking section of this manual.
- Do not store or use grill near gasoline charcoal or other flammable liquids or where flammable vapors may be present.
- Use caution when adjusting charcoal grate height. Handle may be hot when in use.
- Use caution since flames can flare-up when fresh air suddenly comes in contact with fire. When opening the lid, keep hands, face and body a safe distance from hot steam and flame flare-ups.
- Extinguished coals and ashes should be placed a safe distance from all structures and combustible materials.
- Never raise or lower charcoal grate when water is smoking as hot water may splash onto coals.
- Use caution since flames can flare-up when fresh air suddenly comes in contact with fire. When opening the lid, keep hands, face and body a safe distance from hot steam and flame flare-ups.
- After each use, clean the grill thoroughly and apply a light coat of vegetable oil to the interior to prevent rusting. Cover the grill to protect it from excessive rusting.
- Grill is hot when in use. To avoid burns:
 - DO NOT attempt to move the grill
 - Wear protective gloves or oven mitts.
 - DO NOT touch any hot grill surfaces.
 - DO NOT wear loose clothing or allow hair to come in contact with grill.

PREPARATION FOR USE & LIGHTING INSTRUCTIONS



WARNING



OUTDOOR USE ONLY. DO NOT OPERATE GRILL INDOORS OR IN AN ENCLOSED SPACE. Never use grill indoors. Carbon Monoxide poisoning can lead to death.

Curing your grill

Prior to your first use of the Grill, follow the instructions below carefully to cure your grill. Curing your grill will minimize damage to the exterior finish as well as rid the grill of paint odor that can impart unnatural flavors to the first meal prepared on the grill.

IMPORTANT: To protect your grill from excessive rust, the unit must be properly cured and covered at all times when not in use.

Step 1

Lightly coat all interior surfaces of the grill with vegetable oil or vegetable oil spray.

Step 2

Follow the instructions below carefully to build a fire. You may use charcoal and/or wood as fuel for the grill (see “Adding Charcoal/Wood during Cooking” section of this manual).



WARNING



Use only a high grade plain charcoal or charcoal /wood mixture.

NOTE: To extend the life of your grill, make sure that hot coals and wood do not touch the walls of grill.

IF USING CHARCOAL CHIMNEY STARTER, PROCEED TO STEP 5.

If you choose to use charcoal lighting fluid, ONLY use charcoal lighting fluid approved for lighting charcoal. Do not use gasoline, kerosene, alcohol or other flammable material for lighting charcoal. Follow all manufacturer’s warnings and instructions regarding the use of their product. Start with 3.3 lb(1.5 kg) of charcoal. This should be enough charcoal to cook with, once the curing process has been completed. Place the charcoal in the center of each charcoal grate.

Step 3

Saturate charcoal with lighting fluid. With lid open, wait 2 to 3 minutes to allow lighting fluid to soak into charcoal. Store lighting fluid a safe distance from the grill.

Step 4

With grill lid and doors open, stand back and carefully light charcoal through the doors. Allow to burn until covered with a light ash (approximately 20 minutes).



WARNING



Charcoal lighting fluid must be allowed to completely burn off prior to closing grill lid (approximately 20 minutes). Failure to do this could trap fumes from charcoal lighting fluid in grill and may result in a flash-fire or explosion when lid is opened.

Step 5

Place lump or briquette charcoal on top of grate in chimney starter until full. Underneath grate place balled up paper and light with match or lighter thru holes in bottom of chimney sides. Once paper lights, fire will spread up thru charcoal until entire column is glowing red in the bottom with ash formation on top. Pick up by handle and pour lit charcoal into grill.

With coals burning strong, close the lid and doors. Allow the temperature to reach 225°F (107°C) on both heat indicators. Maintain this temperature for 2 hours.

Step 6

Increase the temperature to 400°F (205°C) on charcoal chamber indicator. This can be achieved by adding more charcoal and/or wood (see “Adding Charcoal/Wood During Cooking” section of this manual). Maintain this temperature for 1 hour then allow unit to cool completely.

IMPORTANT: to protect your grill from excessive rust, the unit must be cured periodically and covered at all times when not in use.

OPERATING INSTRUCTIONS



WARNING



DO NOT use grill without charcoal ash tray in place. DO NOT attempt to remove charcoal ash tray while tray contains hot coals.



CAUTION



Always wear oven mitts/gloves when adjusting cooking levels to protect your hands from burns.

Grilling/Searing

Step 1

Follow the instructions below carefully to build a fire. You may use charcoal and/or wood as fuel in the charcoal side of the Hybrid Grill (see “Adding Charcoal/Wood During Cooking” section of this manual).



WARNING



Use only a high grade plain charcoal or charcoal/wood mixture.

If using a **Charcoal Chimney Starter**, follow “Operating Instruction Step 4” or follow all manufacturer’s warnings and instructions regarding the use of their product.

Start with 3.3 pounds (1.5 kg) of charcoal. When charcoal is burning strong, carefully place hot coals in center of the charcoal tray.



WARNING



DO NOT use grill without charcoal ash tray in place. DO NOT attempt to remove charcoal ash tray while tray contains hot coals.

NOTE: To extend the life of your grill, make sure that hot coals and wood do not touch the walls of grill.

IF USING CHARCOAL CHIMNEY STARTER, PROCEED TO STEP 4.

If you choose to use charcoal lighting fluid, ONLY use charcoal lighting fluid approved for lighting charcoal. Do not use gasoline, kerosene, alcohol or other flammable materials for lighting charcoal. Follow all manufacturer's warnings and instructions regarding the use of their product. Start with 3.3 pounds (1.5 kg) of charcoal. Place the charcoal in center of the charcoal tray.

Step 2

Saturate charcoal with lighting fluid. With lid and doors open wait 2 to 3 minutes to allow lighting fluid to soak into charcoal. Store charcoal lighting fluid a safe distance from the grill.

Step 3

With grill lid and doors open, stand back and carefully light charcoal and allow to burn until covered with a light ash (approximately 20 minutes).



WARNING



Charcoal lighting fluid must be allowed to completely burn off prior to closing grill lid and doors (approximately 20 minutes). Failure to do this could trap fumes from charcoal lighting fluid in grill and may result in a flash-fire or explosion when lid is opened.

Step 4

Place cooking grates on grill support lips. Use charcoal tray handle adjuster to position charcoal grates to desired cooking level.



WARNING



Always wear oven mitts/gloves when adjusting cooking levels to protect your hands from burns.

Step 5

Place food on cooking grates and close grill lid. Always use a meat thermometer to ensure food is fully cooked before removing from grill.

Step 6

Allow grill to cool completely, and then follow instructions in the "After-Use Safety" and "Proper Care & Maintenance" sections of this manual.

Flavoring Wood

To obtain your favorite smoke flavor, experiment by using chunks, sticks or chips of flavor producing wood such as hickory, pecan, apple, cherry, or mesquite. Most fruit or nut tree wood may be used for smoke flavoring. Do not use resinous wood such as pine as it will produce an unpleasant taste.

Wood chunks or sticks 3" to 4" (7 to 10 cm) long and 1" to 2" (2 to 4 cm) thick work best. Unless the wood is still green, soak the wood in water for 30 minutes or wrap each piece in foil and tear several small holes in the foil to produce more smoke and prevent the wood from burning too quickly. Only a few pieces of wood are required to obtain a good smoke flavor. A recommended amount for the grill is 5 to 6 wood chunks or sticks. Experiment by using more wood for stronger smoke flavor or less wood for milder smoke flavor.

Additional flavoring wood should not have to be added during the cooking process. However, it may be necessary when cooking very large pieces of food. Follow instructions and cautions in the “Adding Charcoal/Wood During Cooking” section of this manual to avoid injury while adding wood.

Regulating Heat

By adjusting the position of the charcoal tray, the temperature of grill can be regulated. To increase the heat, move the charcoal towards the cooking grates. Lowering it will decrease the temperature. Rotate the crank to raise or lower the position of the charcoal tray to achieve the desired temperature.

To increase heat, more wood and/or charcoal may be needed. Follow instructions in “Adding Charcoal/Wood During Cooking” section of this manual. To maintain the temperature, more wood and/or charcoal may need to be added during the cooking cycle.

NOTE: Dry wood burns hotter than charcoal, so you may want to increase the ratio of wood to charcoal to increase the cooking temperature. Hardwood such as oak, hickory, mesquite, fruit and nut wood are an excellent fuel because of their burning rate. When using wood as fuel, make sure the wood is seasoned and dry. DO NOT use resinous wood such as pine as it will produce an unpleasant taste.

Adding Charcoal/Wood During Cooking

Additional charcoal and/or wood may be required to maintain or increase cooking temperature.

Step 1

Stand back and carefully open grill lid. Use caution since flames can flare-up when fresh air suddenly comes in contact with fire.

Step 2

Wearing oven mitts/gloves, use charcoal tray adjuster to place charcoal tray at the lowest level of cooking chamber. Open doors to allow access to charcoal tray.

Step 3

Stand back at a safe distance and use long cooking tongs to lightly brush aside ashes on hot coals. Use cooking tongs to add charcoal and/or wood to charcoal tray, being careful not to stir-up ashes and sparks. If necessary, use your Charcoal Chimney Starter to light additional charcoal and/or wood and add to existing fire.

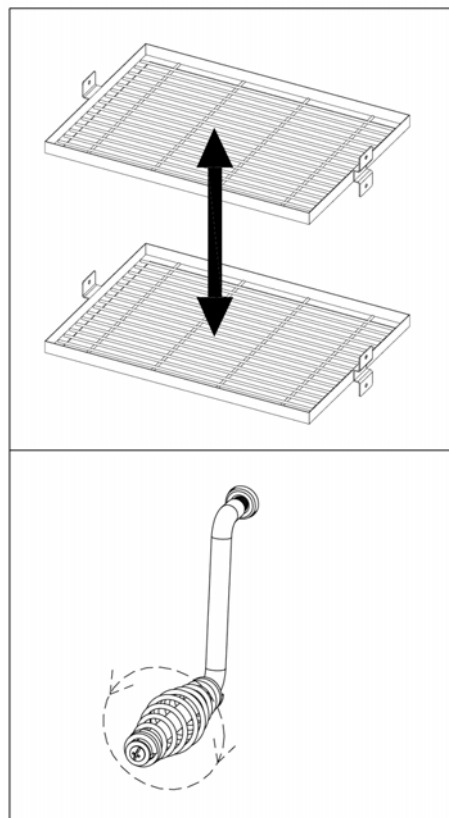

WARNING



Never add charcoal lighting fluid to hot or even warm coals as flashback may occur causing severe burns.

Step 4

When charcoal is burning strong again, wear oven mitts/gloves and carefully return charcoal tray to desired cooking level. Extinguish any hot ashes, coals or embers which may have fallen from doors or beneath and around grill.

Step 5

Close the grill lid and doors. Allow food to continue cooking.

AFTER-USE SAFETY



CAUTION



- Always allow grill and all components to cool completely before handling.
- Never leave coals and ashes in grill unattended. Make sure coals and ashes are completely extinguished before removing.
- Before grill can be left unattended, remaining coals and ashes must be removed from grill. Use caution to protect yourself and property. Place remaining coals and ashes in a non-combustible metal container and completely saturate with water. Allow coals and water to remain in metal container 24 hours prior to disposing.
- Extinguished coals and ashes should be placed a safe distance from all structures and combustible materials.
- With a garden hose, completely wet surface beneath and around the grill to extinguish any ashes, coals or embers which may have fallen during the cooking or cleaning process.
- Cover and store grill in a protected area away from children and pets.

Proper Care & Maintenance

- Cure your grill periodically throughout the year to protect against excessive rust.
- To protect your grill from excessive rust, the unit must be properly cured and covered at all times when not in use.
- Wash cooking grates with hot, soapy water, rinse well and dry. Lightly coat grates with vegetable oil or vegetable oil spray.
- Clean inside and outside of grill by wiping off with a damp cloth. Apply a light coat of vegetable oil or vegetable oil spray to the interior surface to prevent rusting.
- If rust appears on the exterior surface of your grill, clean and buff the affected area with steel wool or fine grit emery cloth. Touch-up with a good quality high-temperature resistant paint.
- Never apply paint to the interior surface. Rust spots on the interior surface can be buffed, cleaned, and then lightly coated with vegetable oil or vegetable oil spray to minimize rusting.

How do I season my Cast Iron Grates?

1. Wash grates in hot, soapy water. Rinse grates and dry completely using a towel. Towel may become discolored. This is normal.
2. Apply a thin, even coating of melted shortening (Crisco, as an example) to the grates with a soft cloth or paper towel. Apply to both sides of the grates.
3. Heat grill with a small fire to around 350 degrees. Place grates in grill not directly over the coals and close lid. Leave closed for at least one hour. Let grates remain in grill until cool.
4. Place grates in proper position in the grill.

Your cast iron grates should be properly seasoned and ready to use!

Tips & Suggestions:

1. Seasoning is an ongoing process. Periodically reapply the oil to grates with a soft cloth, especially if you see any rust developing or before long periods of storage.
2. Never put your Cast Iron Grates in the dishwasher or allow to air dry.
3. IF rust does appear, remove with a grill brush and repeat the seasoning process.
4. Cleaning of the grates should be done before the cooking begins, not after the cooking is over. A little residue left on the Cast Iron crates helps protect them between uses.
5. The more Cast Iron Grates are used the better the non-stick qualities become. This is a great excuse to grill more often!

Packing List



ATTENTION



Please do not withdraw all small parts from the packing boxes immediately
Each assembly step in this instruction manual has instructed you to find the particular part(s) from the packing box quickly. We strongly recommend that you read through the assembly procedure before proceeding assembly.

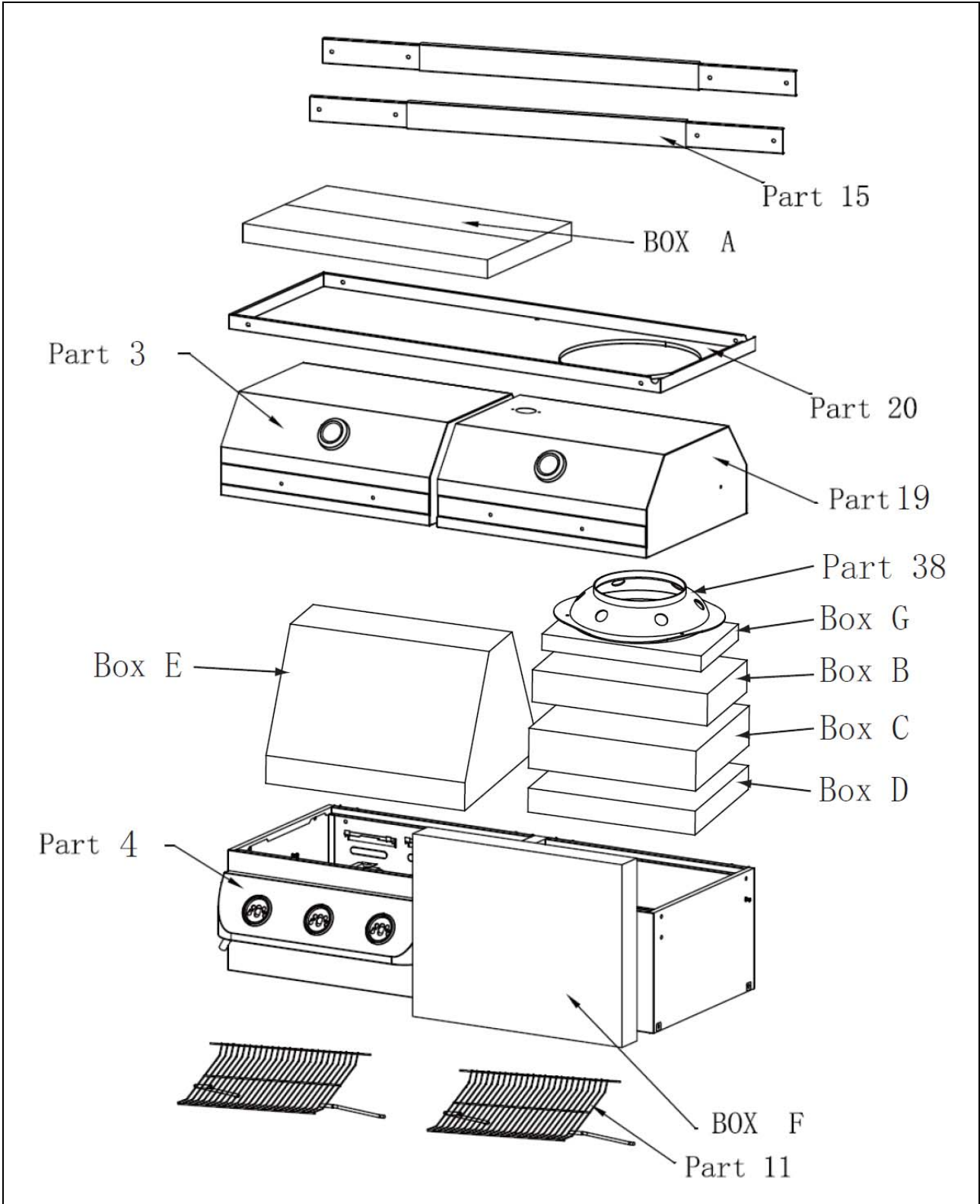

Box A		
Part 17	Left Pivot Leg	1pc
Part 18	Right Pivot Leg	1pc
Part 33	Left Wheel Leg	1pc
Part 34	Right Wheel Leg	1pc

Box B		
Part 12	Charcoal Grill Cooking Grate	2pcs
Part 13	Flame Tamer	3pcs
Part 23	Side Burner Cooking Grate	1pc
Part 32	Gas Grill Cooking Grate	2pcs

Box C		
Part 2	Charcoal Chimney	1pc
Part 6	Grill Handle	1pc
Part 8	Lid Handle	3pcs
Part 16	Leg Brace	2pcs
Part 30	Grease Cup	1pc
Part 35	Wheel	2pcs

Box E		
Part 22	Side Burner Assembly	1pc

Box F		
Part 14	Bottom Rack	1pc
Part 39	Middle Panel	1pc

Box G		
Part 24	Side Burner Control Panel	1pc







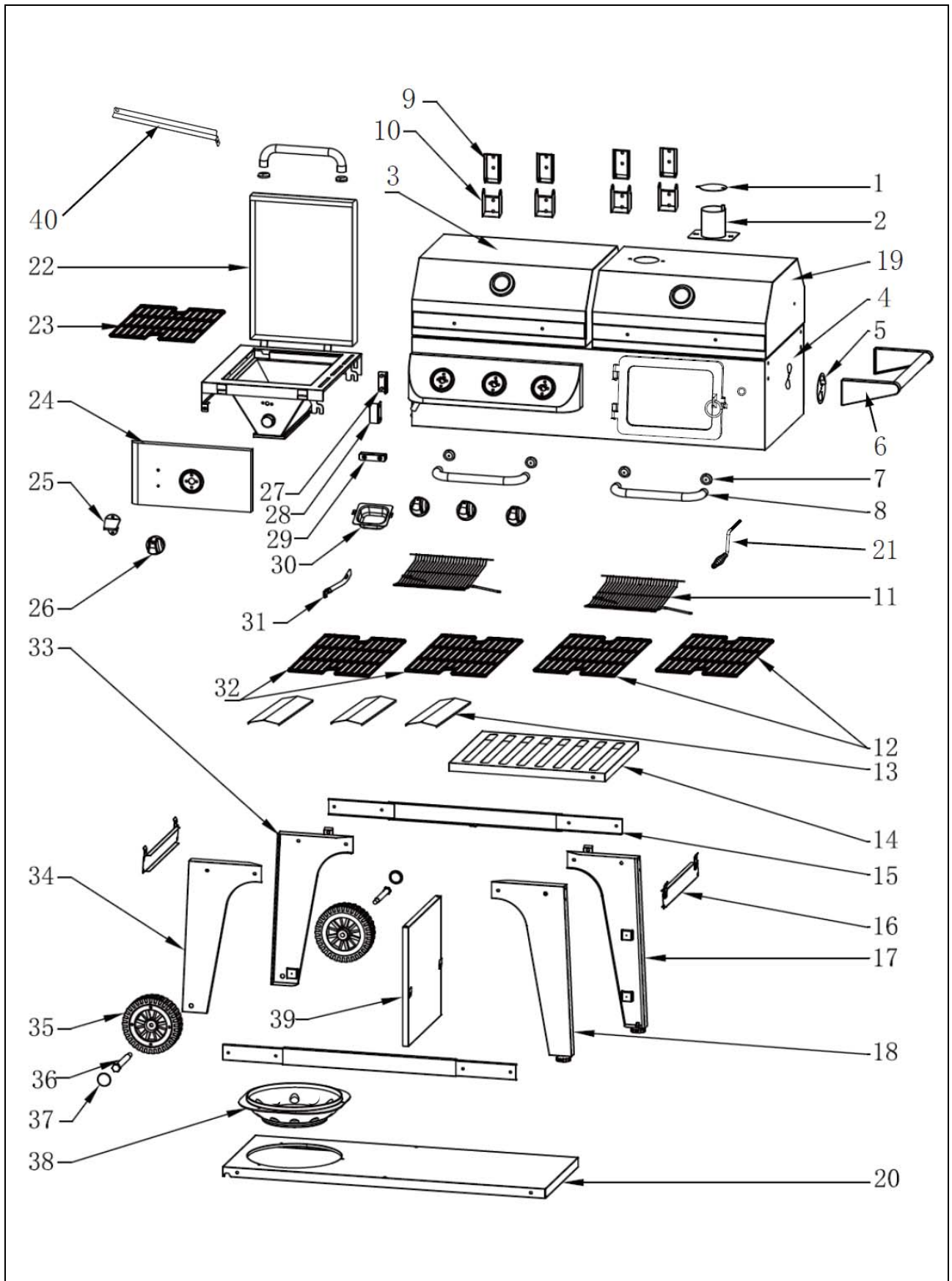



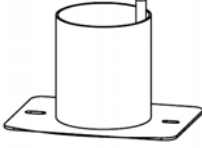

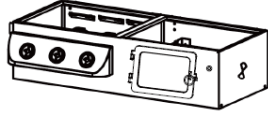
Box D		
Part 1	Chimney Cover	1pc
Part 5	Air Vent	1pc
Part 7	Bezel	6pcs
Part 21	Crank	1pc
Part 25	Bottle Opener	1pc
Part 26	Control Knob	4pcs
Part 27	Side Burner Bracket (Left)	1pc
Part 28	Side Burner Bracket (Right)	1pc
Part 29	Charcoal Grease Tray Handle	1pc
Part 31	Cooking Grate Lifter	1pc
Part 36	Wheel Axle	2pcs
Part 37	Wheel Cover	2pcs
Part 40	Side Burner Supporting Bar	1pc
Part 9	Upper Hinge	4pcs
Part 10	Lower Hinge	4pcs

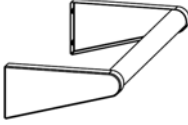
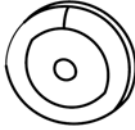

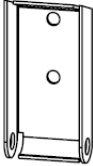
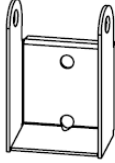

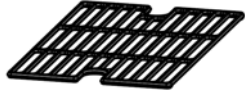
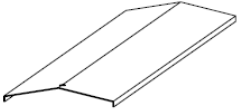
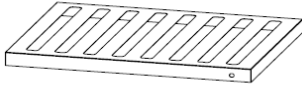

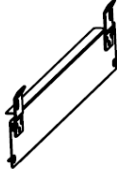
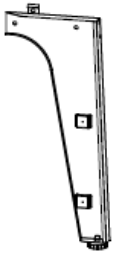

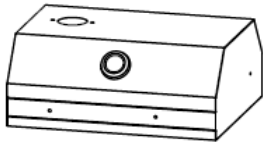
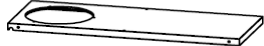

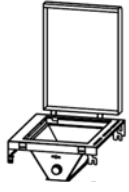

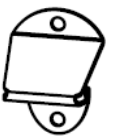

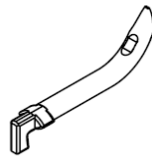

Not Place In Small Box		
Part 11	Warming Rack	2pcs
Part 15	Middle Brace	2pcs
Part 20	Bottom Shelf	1pc
Part 38	Tank Fixture	1pc
Part 4	Grill Body Assembly	1pc
Part 3	Left Lid Assembly (Gas)	1pc
Part 19	Right Lid Assembly (Charcoal)	1pc

Product Diagram



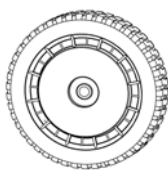
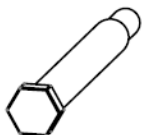

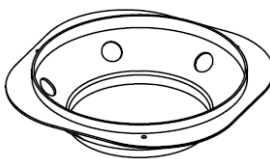



Component List

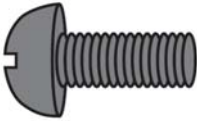

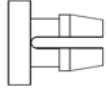
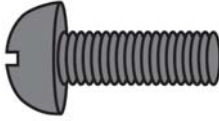
<p>1.Chimney Cover</p>  <p>Box D Qty: 1 pc</p>	<p>2.Charcoal Chimney</p>  <p>Box C Qty: 1 pc</p>	<p>3.Left Lid Assembly (Gas)</p>  <p>Qty: 1 pc</p>	<p>4.Grill Body Assembly</p>  <p>Qty: 1 pc</p>
<p>5.Air Vent</p>  <p>Box D Qty: 1 pc</p>	<p>6.Grill Handle</p>  <p>Box C Qty: 1 pc</p>	<p>7.Bezel</p>  <p>Box D Qty: 6 pcs</p>	<p>8. Lid Handle</p>  <p>Box C Qty: 3 pcs</p>
<p>9. Upper Hinge</p>  <p>Box D Qty: 4 pcs</p>	<p>10. Lower Hinge</p>  <p>Box D Qty: 4 pcs</p>	<p>11.Warming Rack</p>  <p>Qty: 2 pcs</p>	<p>12.Charcoal Grill Cooking Grate</p>  <p>Box B Qty: 2 pcs</p>
<p>13.Flame Tamer</p>  <p>Box B Qty: 3 pcs</p>	<p>14.Bottom Rack</p>  <p>Box F Qty: 1 pc</p>	<p>15.Middle Brace</p>  <p>Qty: 2 pcs</p>	<p>16.Leg Brace</p>  <p>Box C Qty: 2 pcs</p>
<p>17.Left Pivot Leg</p>  <p>Box A Qty: 1 pc</p>	<p>18.Right Pivot Leg</p>  <p>Box A Qty: 1 pc</p>	<p>19. Right Lid Assembly (Charcoal)</p>  <p>Qty: 1 pc</p>	<p>20.Bottom Shelf</p>  <p>Qty: 1 pc</p>

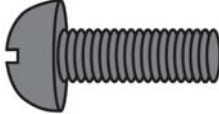
<p>21. Crank</p>  <p>Box D Qty: 1 pc</p>	<p>22.Side Burner Assembly</p>  <p>Box E Qty: 1 pc</p>	<p>23.Side Burner Cooking Grate</p>  <p>Box B Qty: 1 pc</p>	<p>24.Side Burner Control Panel</p>  <p>Box G Qty: 1 pc</p>
<p>25.Bottle Opener</p>  <p>Box D Qty: 1 pc</p>	<p>26.Control Knob</p>  <p>Box D Qty: 4 pcs</p>	<p>27.Side Burner Bracket (Left)</p>  <p>Box D Qty: 1 pc</p>	<p>28. Side Burner Bracket (Right)</p>  <p>Box D Qty: 1 pc</p>
<p>29.Charcoal Grease Tray Handle</p>  <p>Box D Qty: 1 pc</p>	<p>30.Grease Cup</p>  <p>Box C Qty: 1 pc</p>	<p>31.Cooking Grate Lifter</p>  <p>Box D Qty: 1 pc</p>	<p>32. Gas Grill Cooking Grate</p>  <p>Box B Qty: 2 pcs</p>
<p>33.Left Wheel Leg</p>  <p>Box A Qty: 1 pc</p>	<p>34.Right Wheel Leg</p>  <p>Box A Qty: 1 pc</p>	<p>35.Wheel</p>  <p>Box C Qty: 2 pcs</p>	<p>36. Wheel Axle</p>  <p>Box D Qty: 2 pcs</p>
<p>37.Wheel Cover</p>  <p>Box D Qty: 2 pcs</p>	<p>38. Tank Fixture</p>  <p>Qty: 1 pc</p>	<p>39.Middle Panel</p>  <p>Box F Qty: 1 pc</p>	<p>40. Side Burner Supporting Bar</p>  <p>Box D Qty: 1 pc</p>

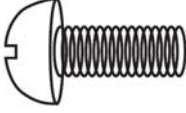
Hardware List

Item No.	Item name	Diagram	Qty
A	M6 X 12mm Bolt (Black)		39
B	M12 Washer		2
C	Plastic Rivet		3
D	M6 X 15mm Bolt (Black)		8
E	Hex Nut Wrench		1
F	M6 X 25mm Bolt (Black)		4
G	Cotter Pin		9
H	M6 Locking Nut		1
I	M6 X 12mm Bolt (Sliver)		2

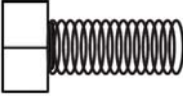
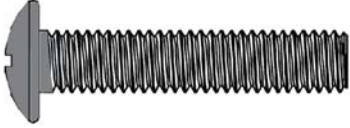
Hardware List

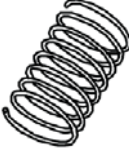
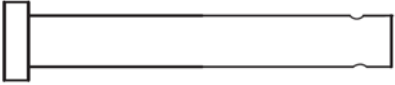
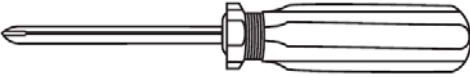
J	M6 X 12mm Hexagonal Bolt		4
K	M6 X 35mm Bolt (Black)		16
L	M8 Cap Nut		1
M	Spring		1
N	Hinge Pin		4
O	Screwdriver		1

Replacement Part List (I)

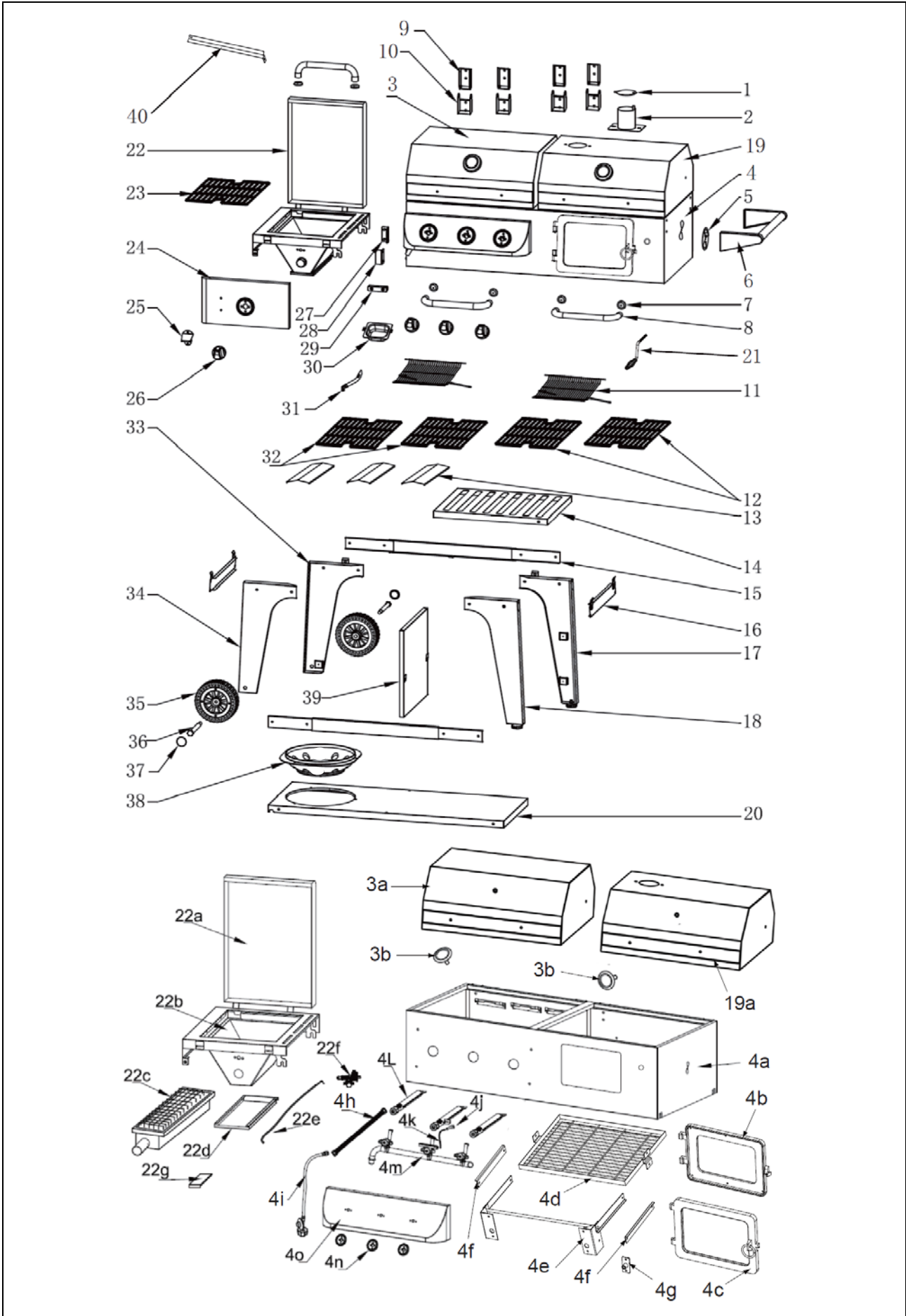

Replacement Part List (II)

1.	Chimney Cover	6	Grill Handle	22e	Side Burner Ignition Electrode With Wire
2.	Charcoal Chimney	7	Bezel	22f	Side Burner Valve
3	Left Lid Assembly (Gas)	8	Lid Handle	22g	Side Burner Electrode Cover
3a	Left Lid (Gas)	9	Upper Hinge	23	Side Burner Cooking Grate
3b	Thermometer	10	Lower Hinge	24	Side Burner Control Panel
4	Grill Body Assembly	11	Warming Rack	25	Bottle Opener
4a	Grill Body	12	Charcoal Grill Cooking Grate	26	Control Knob
4b	Bottom Charcoal Door	13	Flame Tamer	27.	Side Burner Bracket(Left)
4c	Top Charcoal Door	14	Bottom Rack	28.	Side Burner Bracket(Right)
4d	Charcoal Tray	15	Middle Brace	29.	Charcoal Grease Tray Handle
4e	Charcoal Tray Lifter	16	Leg Brace	30.	Grease Cup
4f	Charcoal Tray Lifter Bar	17	Left Pivot Leg	31.	Cooking Grate Lifter
4g	Crank Holder	18	Right Pivot Leg	32.	Gas Grill Cooking Grate
4h	Corrugate Gas Tube	19	Right Lid Assembly (Charcoal)	33.	Left Wheel Leg
4i	Regulator	19a	Right Lid (Charcoal)	34.	Right Wheel Leg
4j	Ignition Electrode (Main burner)	20	Bottom Shelf	35.	Wheel
4k	Ignition Wire	21	Crank	36.	Wheel Axle
4L	Burner	22	Side Burner Assembly	37.	Wheel Cover
4m	Manifold With Gas Valves	22a	Side Burner Lid	38.	Tank Fixture
4n	Control Knob bezel	22b	Side Burner Bottom Body	39.	Middle Panel
4o	Control Panel	22c	Infra-red Side Burner	40	Side Burner Supporting Bar
5	Air Vent	22d	Side Burner Grease Tray		

Assembly Procedures

Step 1: Attach the **Leg Brace (16)** to the **Left Wheel Leg (33)** and **Right Wheel Leg (34)** by using 4 pcs of **Bolts (A)**.

Tips. Each "Wheel Leg" has a hole at the bottom. (Please see the Gray Triangles)

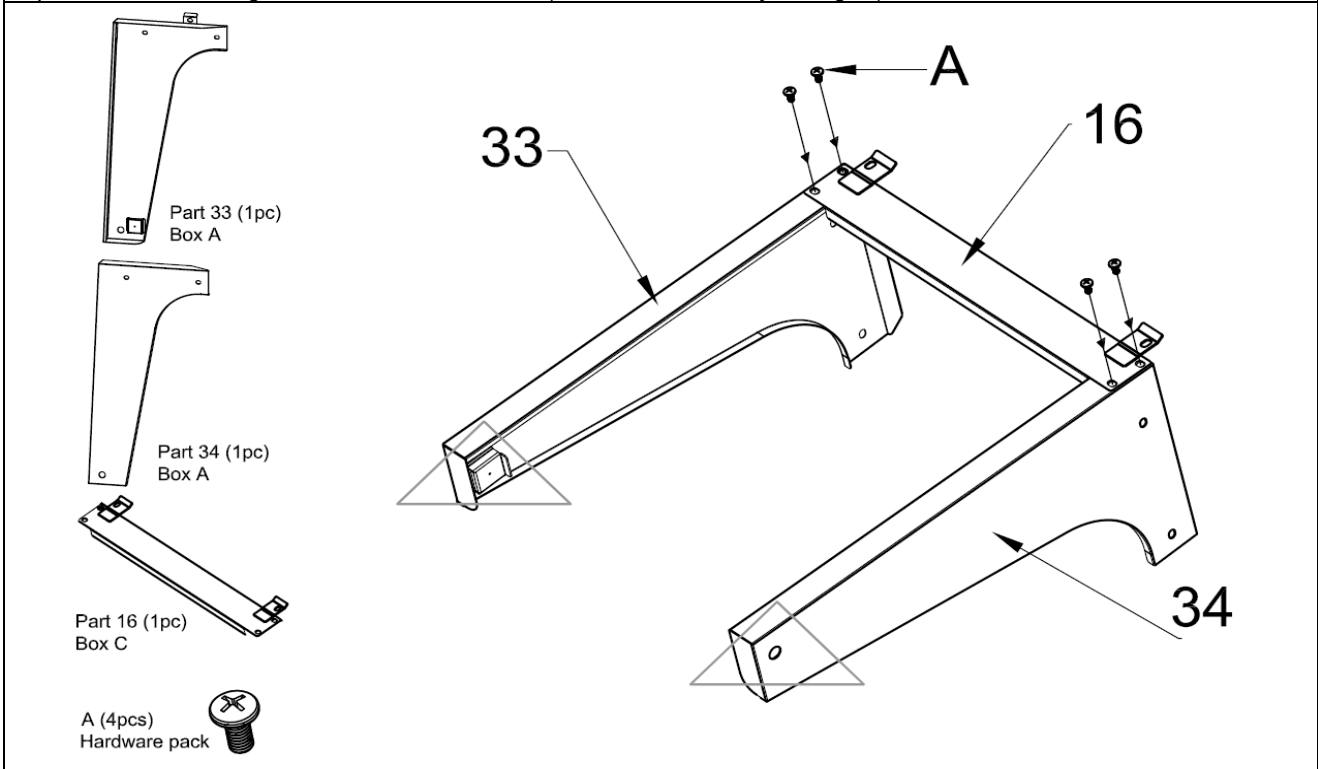

Step 2: Attach the **Leg Brace (16)** to the **Left Pivot Leg (17)** and **Right Pivot Leg (18)** by using 4 pcs of **Bolts (A)**.

Tips. Each "Pivot Leg" has a leg adjuster at the bottom. (Please see the Gray Triangles)

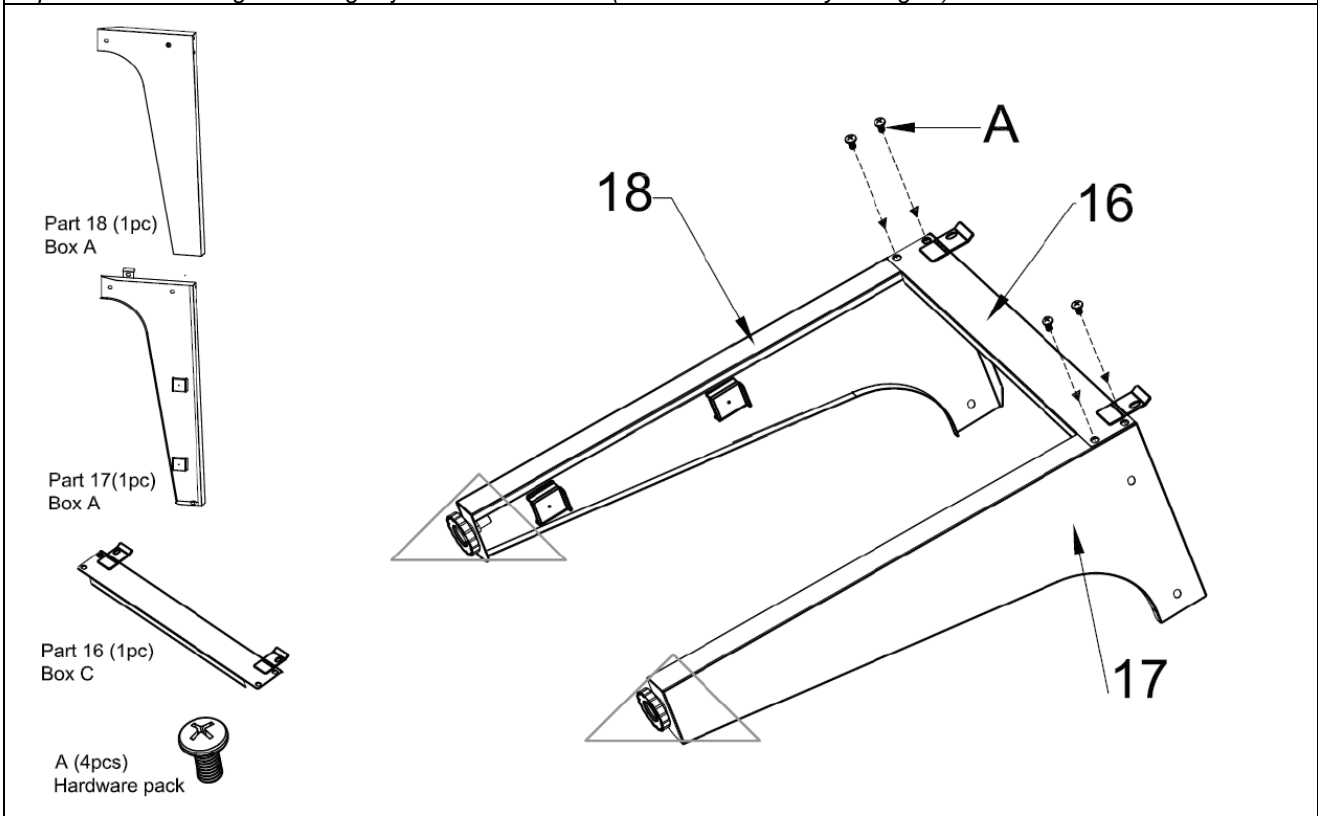

Step 3: Place the legs on the floor at upside down position per shown. Attach the 2 pcs of **Middle Brace (15)** by using 8 pcs of **Bolt (A)**

Tips. Make sure the middle bracket must be on top during the assembly and pointing into inside. (Please see the Gray Triangles)

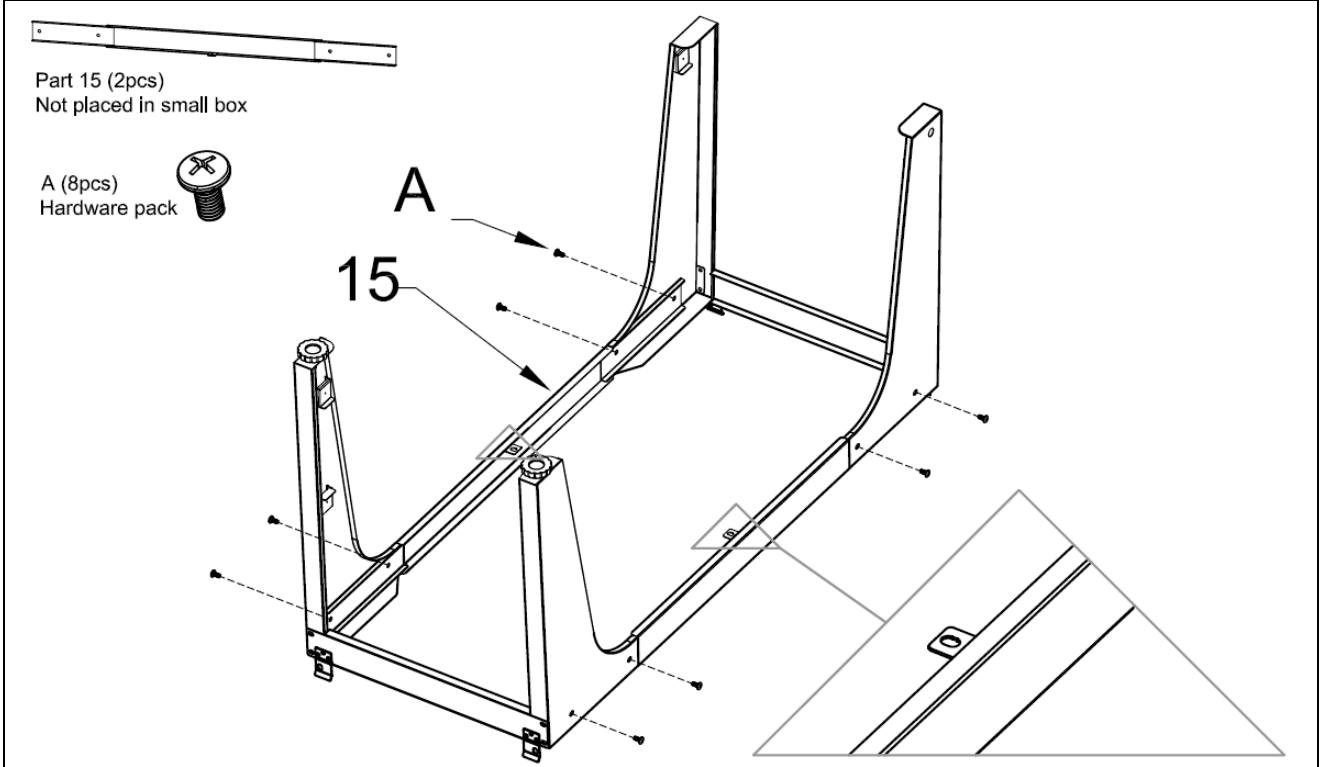

Step 4: Attach the **Bottom Shelf (20)** to the Legs assembly by using 4 pcs of **Bolts (A)**

Tips: Make sure the big tank hole of bottom shelf should be placed at the side of SHORT leg opposite the leg adjustor. (Please see the Gray Triangles)

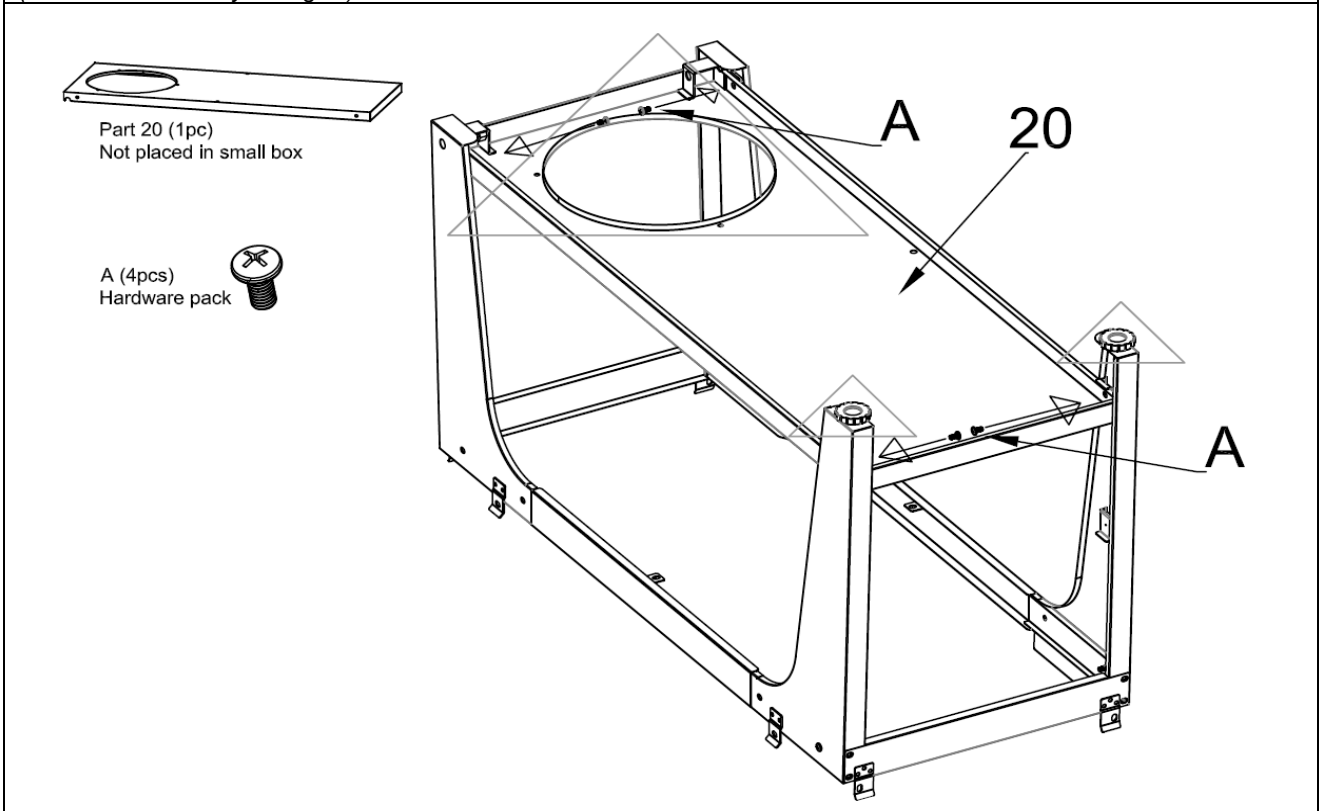

Step 5: Attach the 2 pcs of **Wheel (35)** to short leg sides by using 2 pcs of **Wheel Washer (B)** and **Wheel Axle (36)**. The Wheel Axle can be fastened the **Hex Nut Wrench (E)**. Attach the **Wheel Cover (37)** to the wheels.

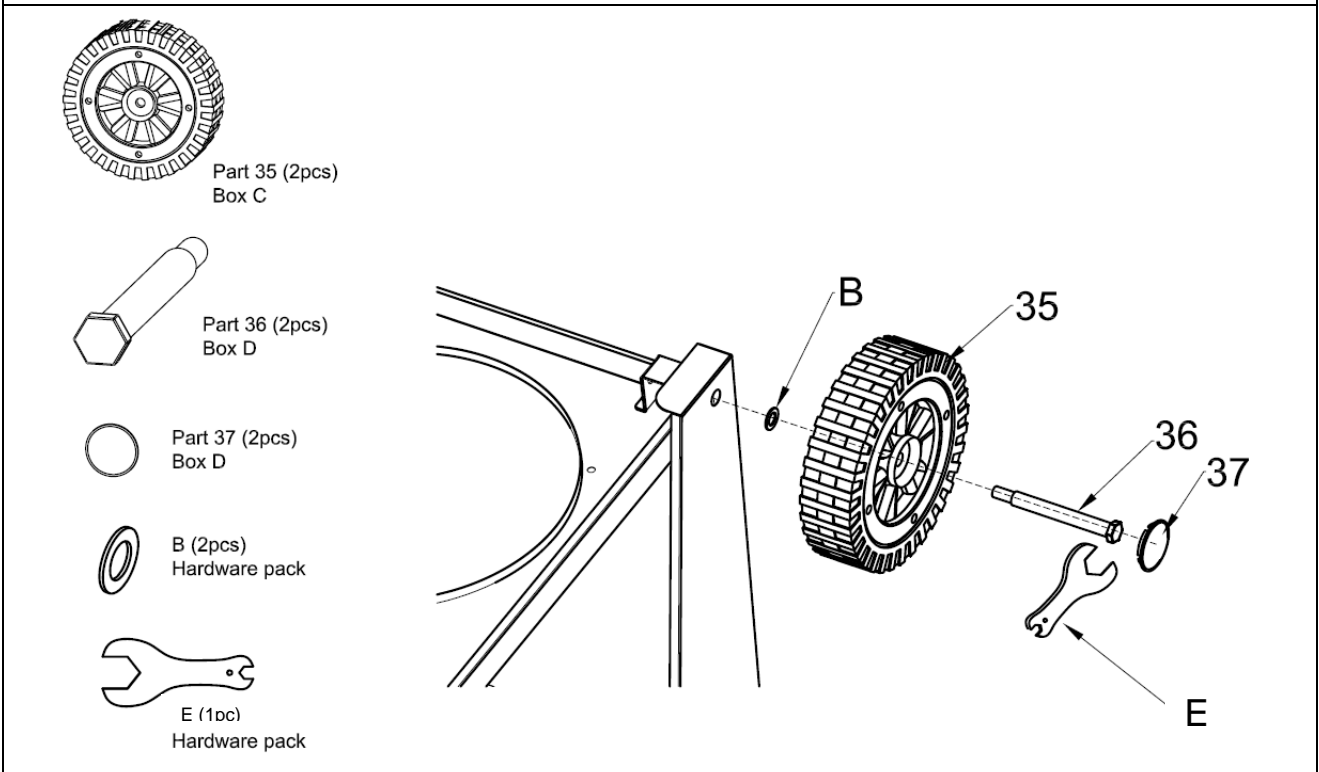

Step 6: Attach the **Middle Panel (39)** to the bottom cart by using 4pcs of **Bolts (A)**.

Tips: Make sure the middle panel should be placed with bracket on opposite side of big tank hole. (Please see the Gray Triangles).

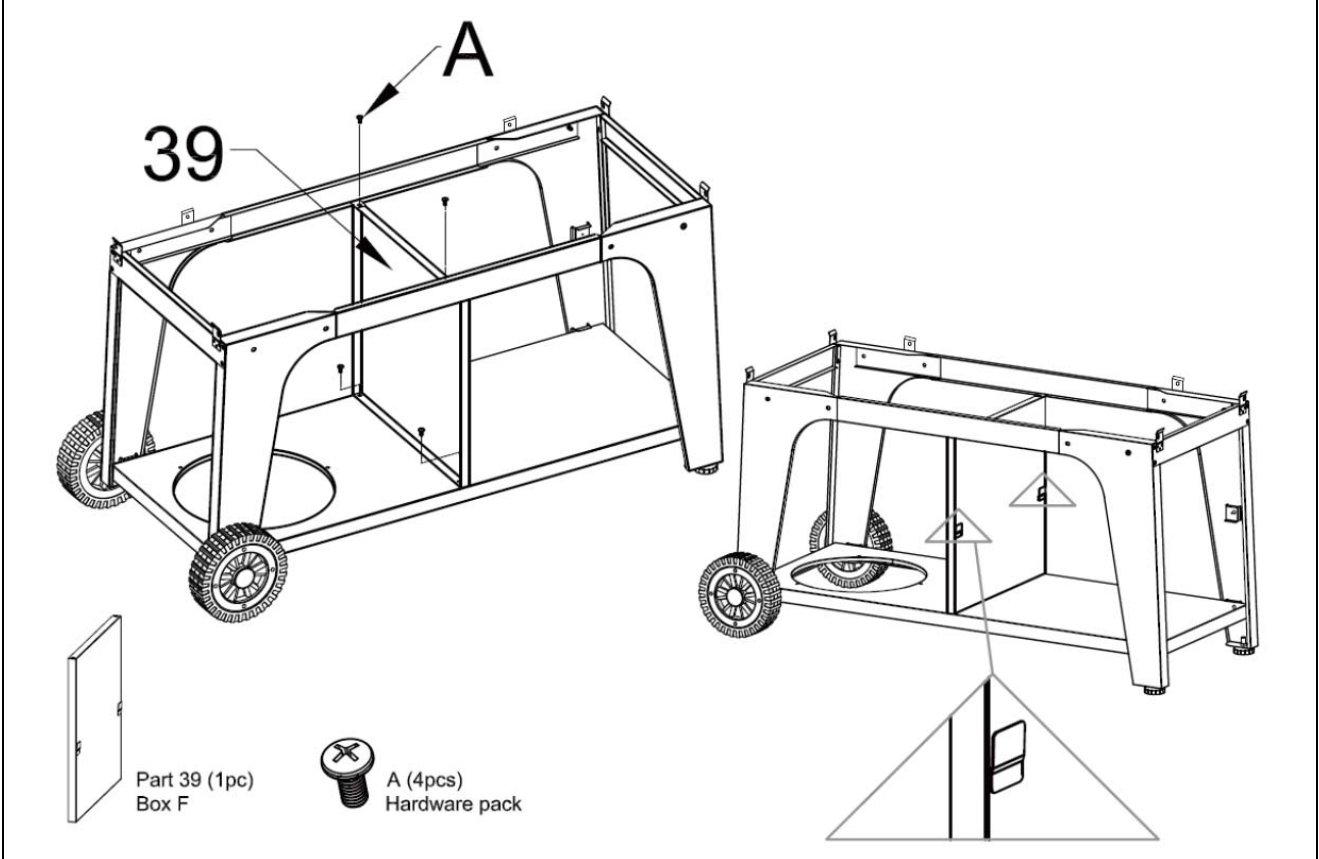

Step 7: Attach the **Bottom Rack (14)** to the bottom cart by using 2 pcs of **Bolt (A)**.

Tip: Attach the bottom rack to bracket first per (a), then fasten the bolts per (b). (Please see the Gray Triangles).

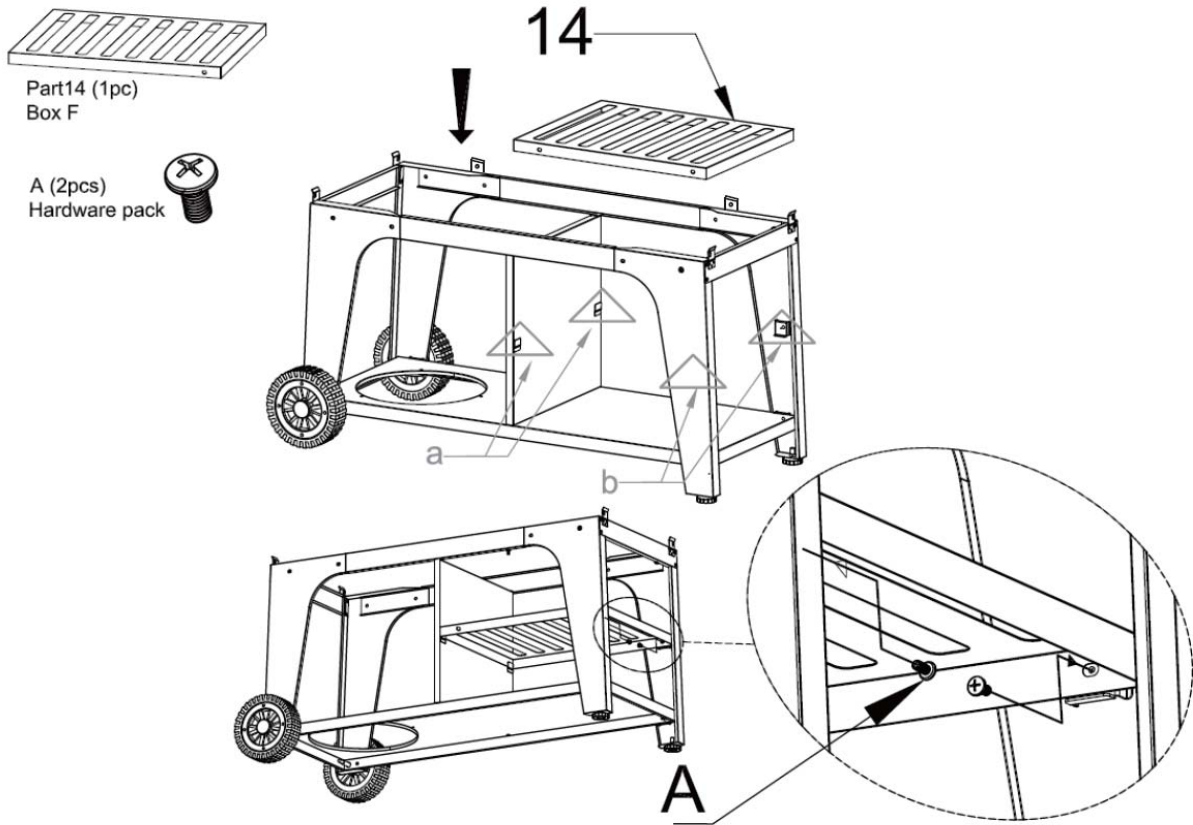

Step 8: Attach the **Tank Fixture (38)** to the big hole of bottom cart by snapping in with 3 pcs of **Plastics Rivet (C)**.

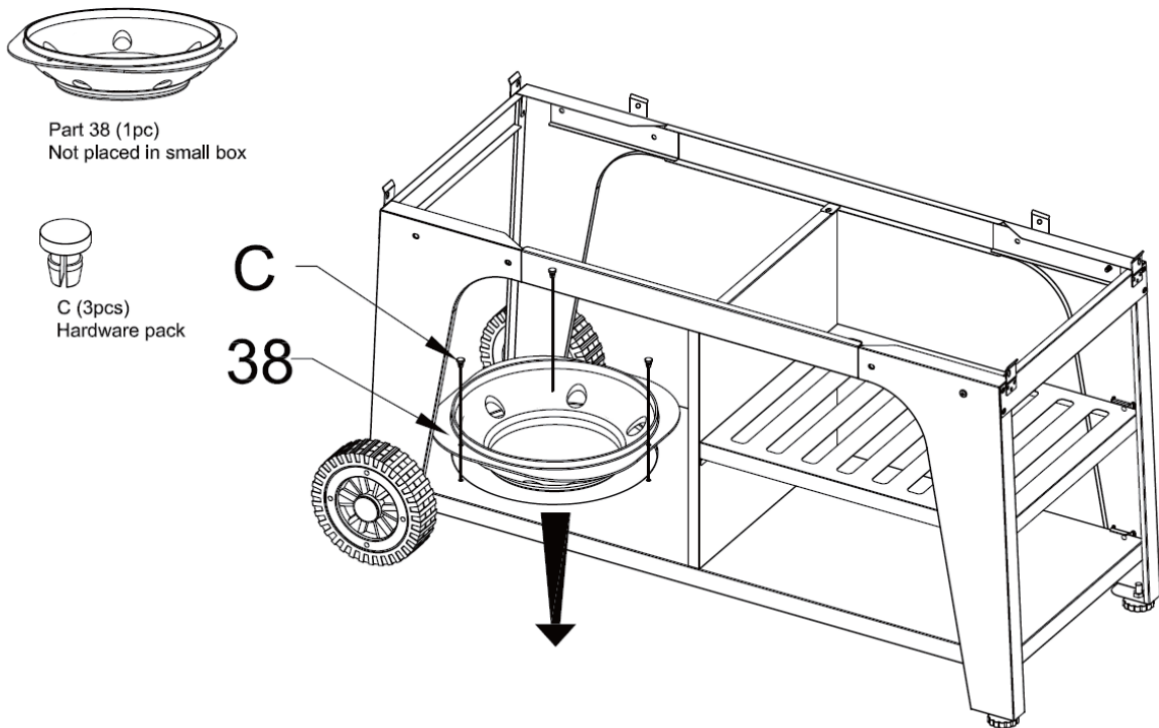

Step 9: This step requires 2 people! Attach the **Grill Body Assembly (4)** on the bottom cart by using 6 pcs of **Bolt (D)** .

*Tips: Do not tighten all the screws during installing each bolt. Make sure the grill body should be well aligned with the bottom cart braces then tighten all bolts.
If either of the middle brace cannot be aligned with the front or back grill body. Simply adjust the position of middle panel and middle brace by loosening the top bolt. These top bolts can be found through the charcoal chamber when the charcoal tray doesn't in place. Tighten all bolt on the grill body after tighten the top bolts.*

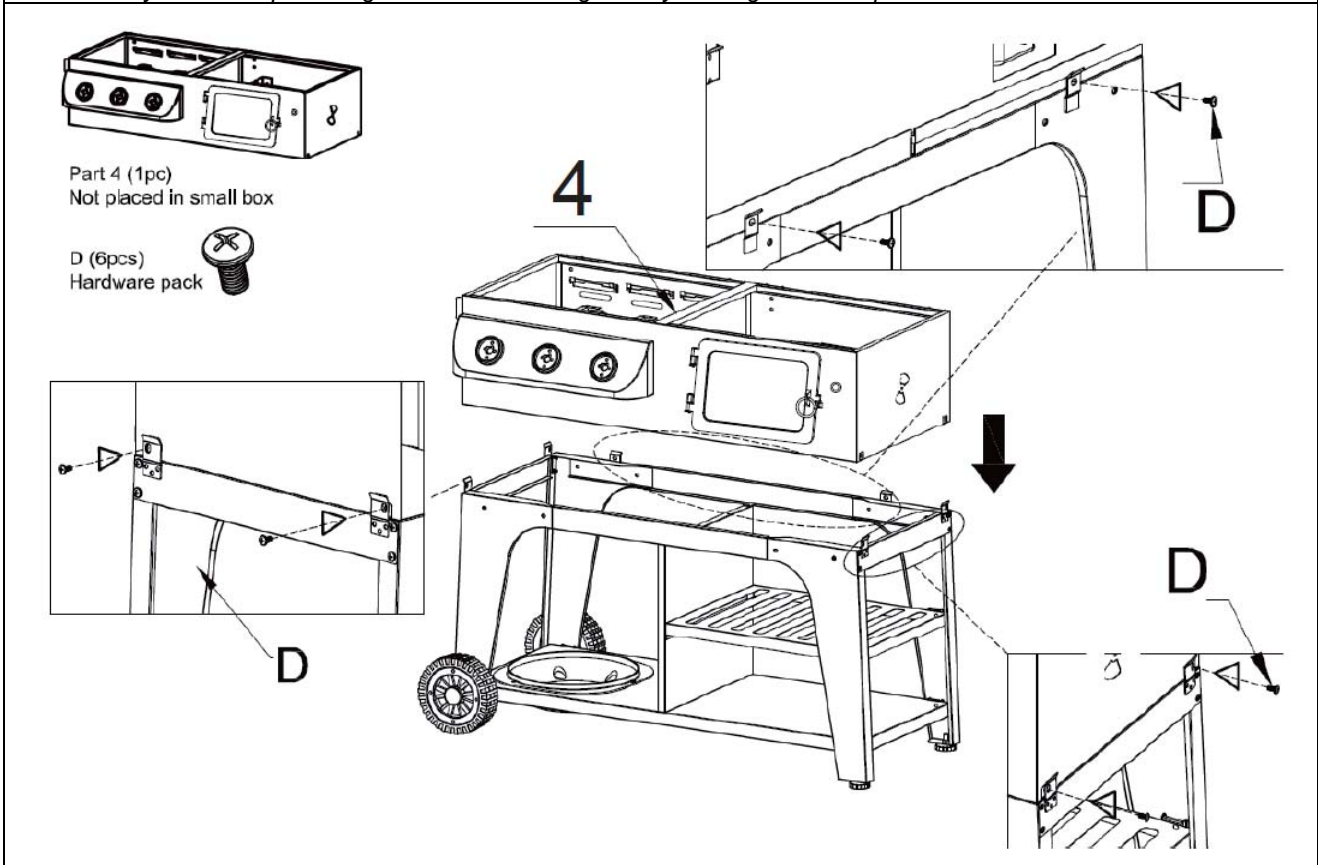

Step 10: Attach the **Air Vent (5)** to the charcoal side of grill body by using 1pc of **Bolt (A)** and **Nut (H)**.

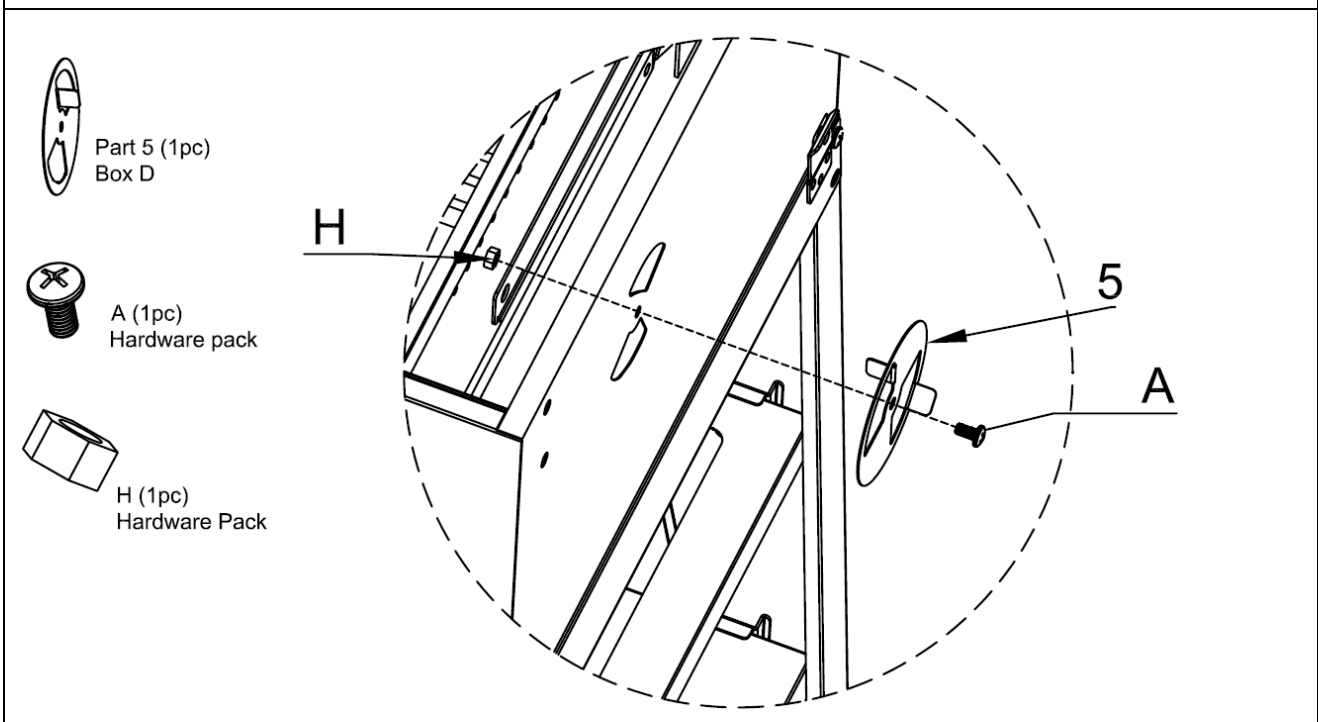

Step 11: Rotate the **Crank (21)** into the crank holder on the charcoal side of grill body then using 1 pc of **Cotter Pin (G)** to fix the crank.

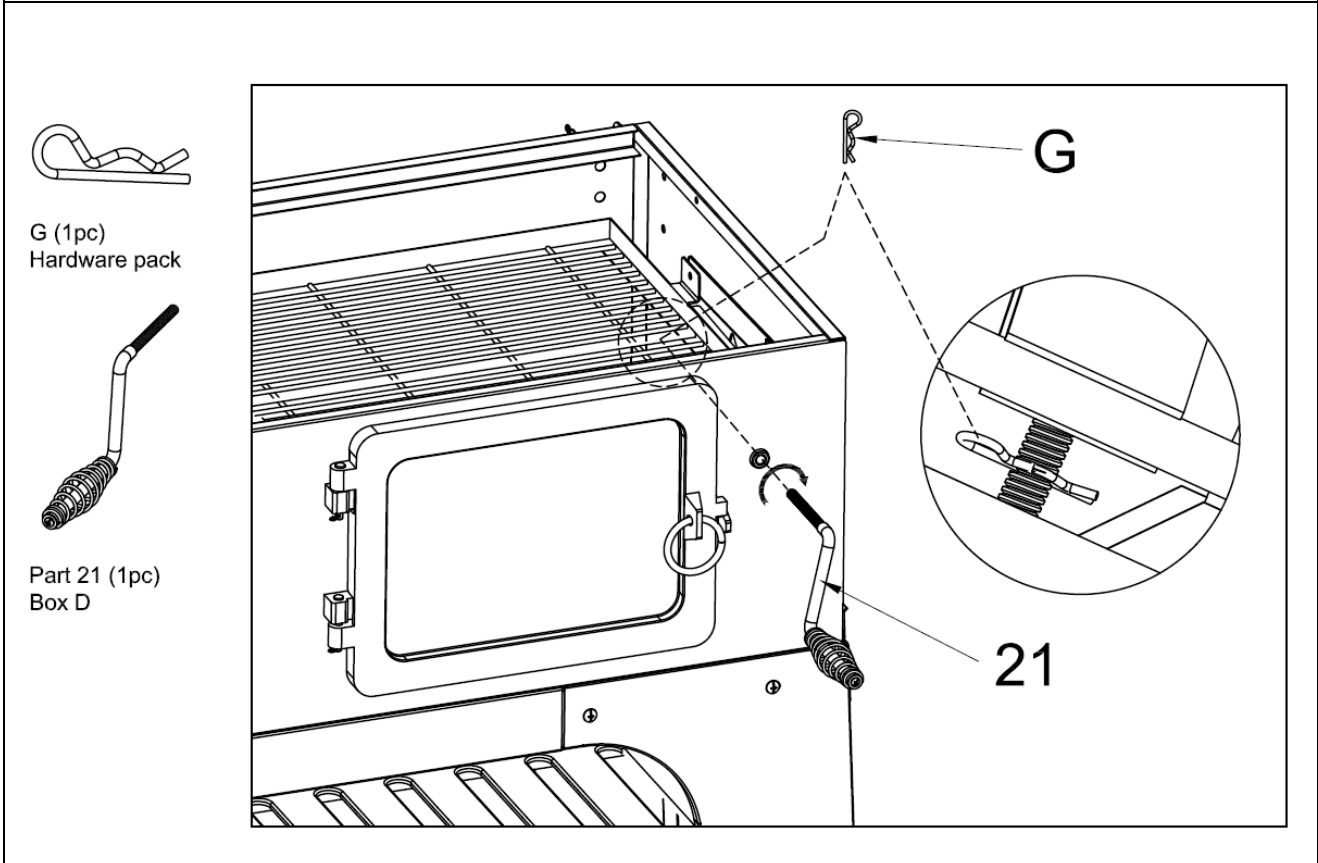

Step 12: Attach the **Grill Handle (6)** to the grill body by using 4 pcs of **Hexagonal Bolt (J)**. These bolts can be fastened by **Hex Nut Wrench (E)**.

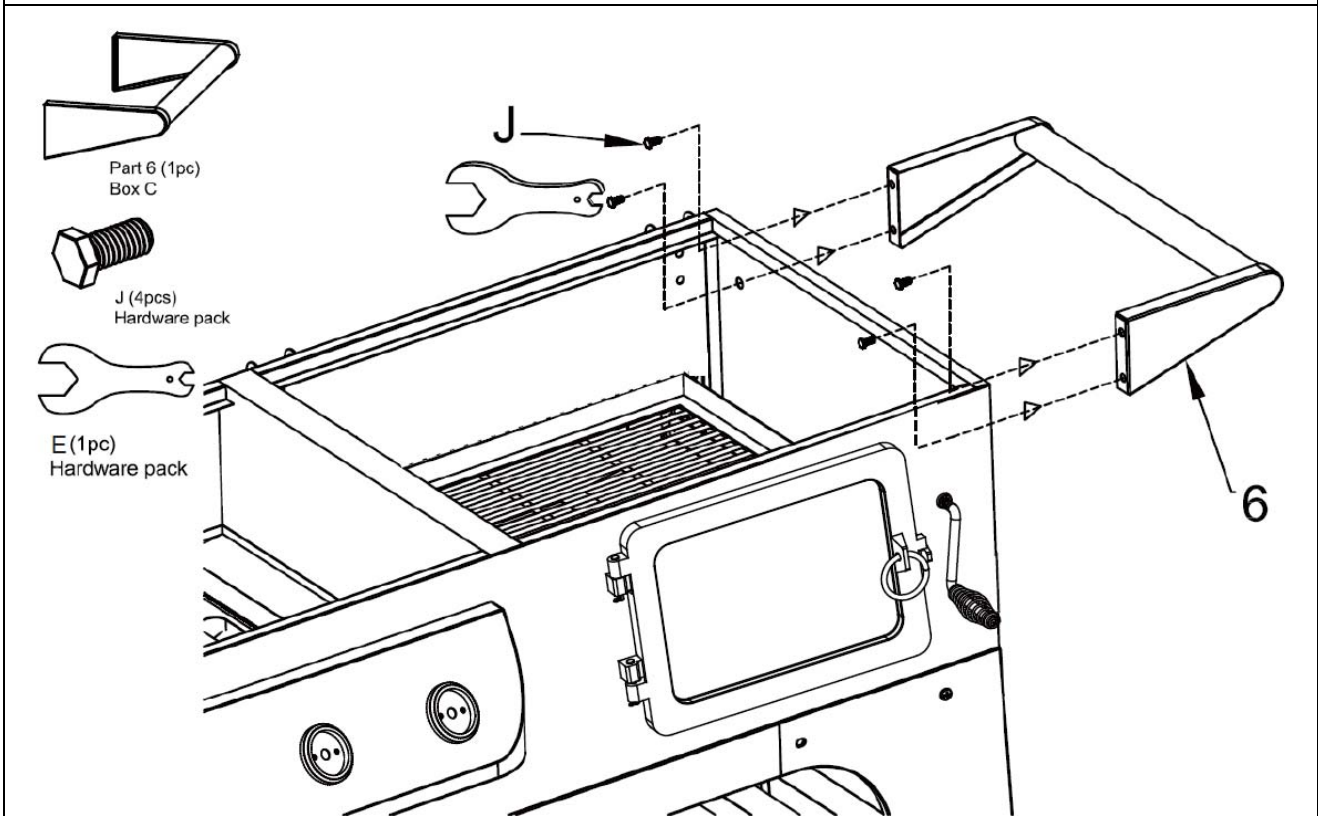

Step13: Attach **Left and Right Side Burner Bracket (27 and 28)** to the grill body by using 2 pcs of **Bolt (A)**.



Part 27 (1pc)
Box D



Part 28 (1pc)
Box D



A (2 pcs)
Hardware pack

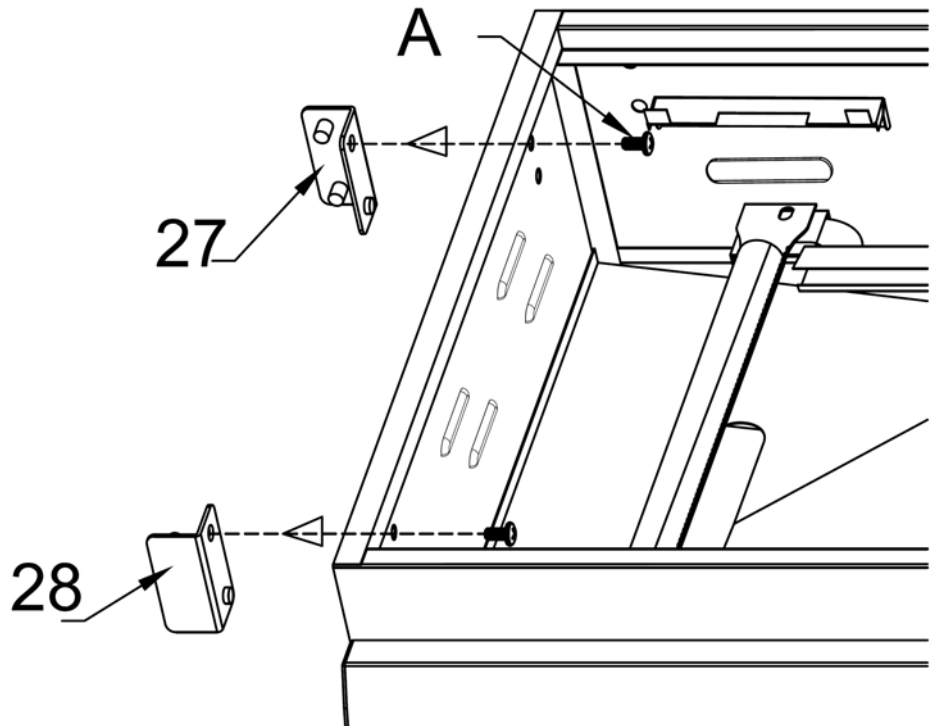

Step14: Attach the **Side Burner Assembly (22)** on the side burner brackets per following shown.

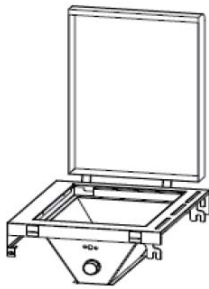

Part 22 (1pc)
Box E

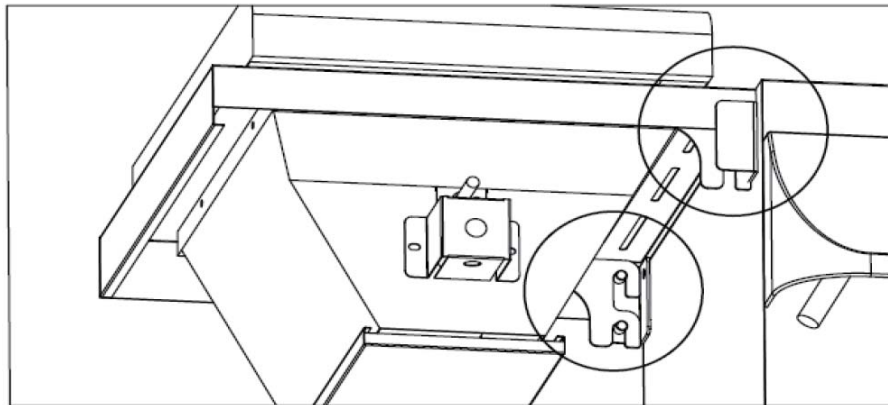
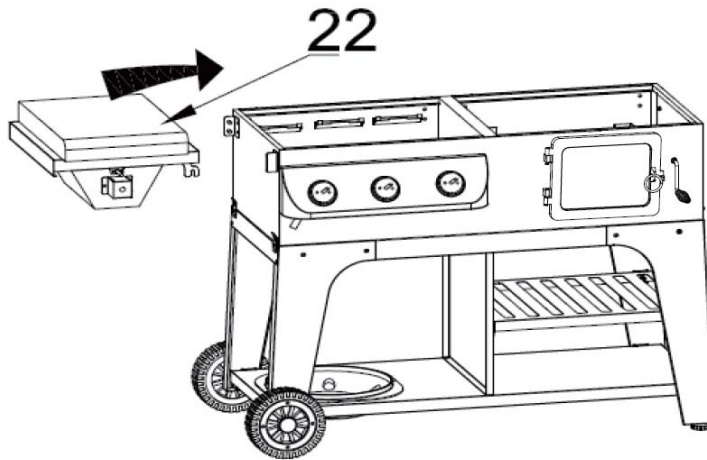

Step15: Secure the side burner assembly by using 2pcs of **Bolt (A)**.

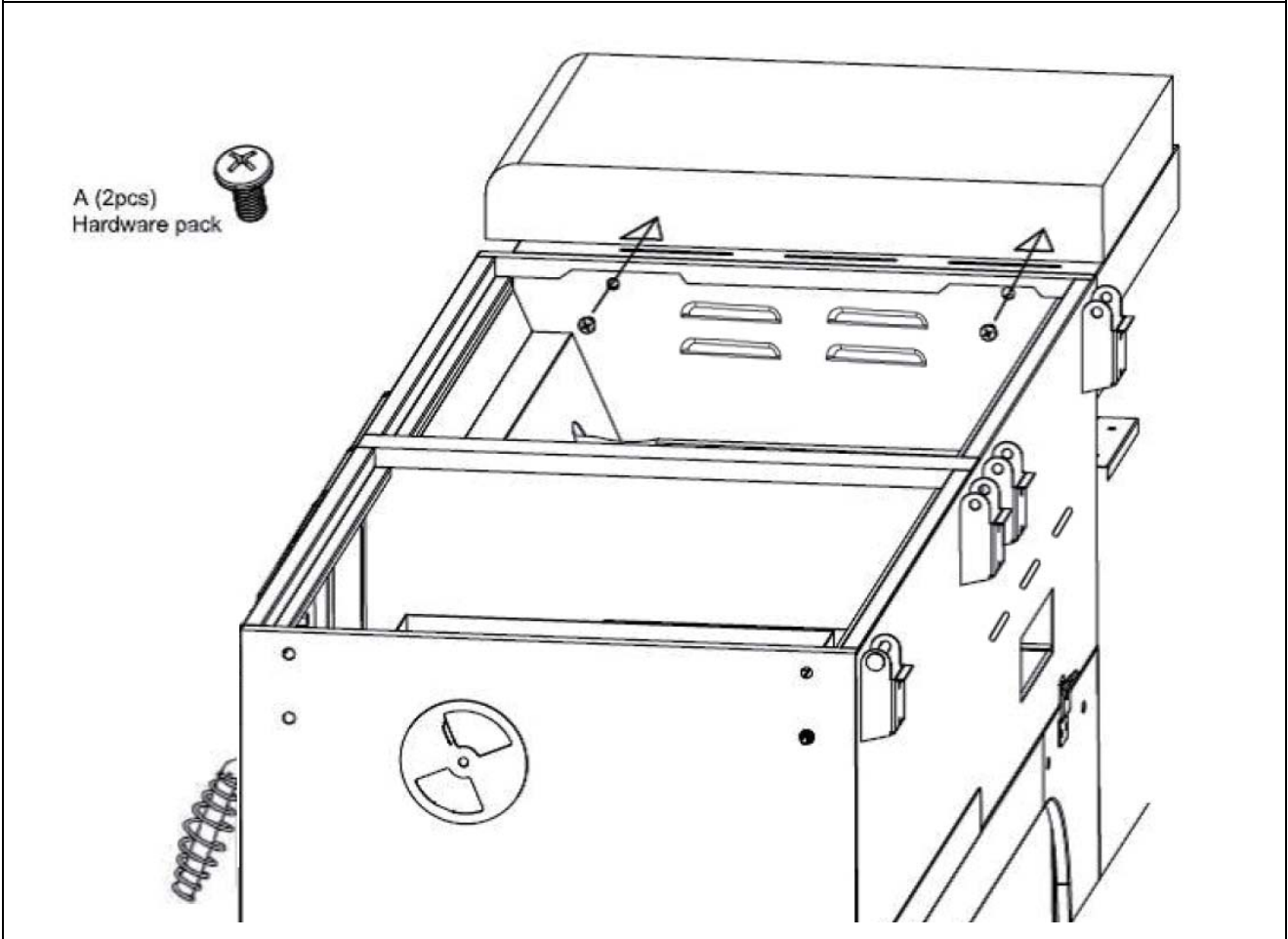

Step16: Attach the **Bottle Opener (25)** to the **Side Burner Control Panel (24)** by using 2 pcs of **Bolt (I)**.

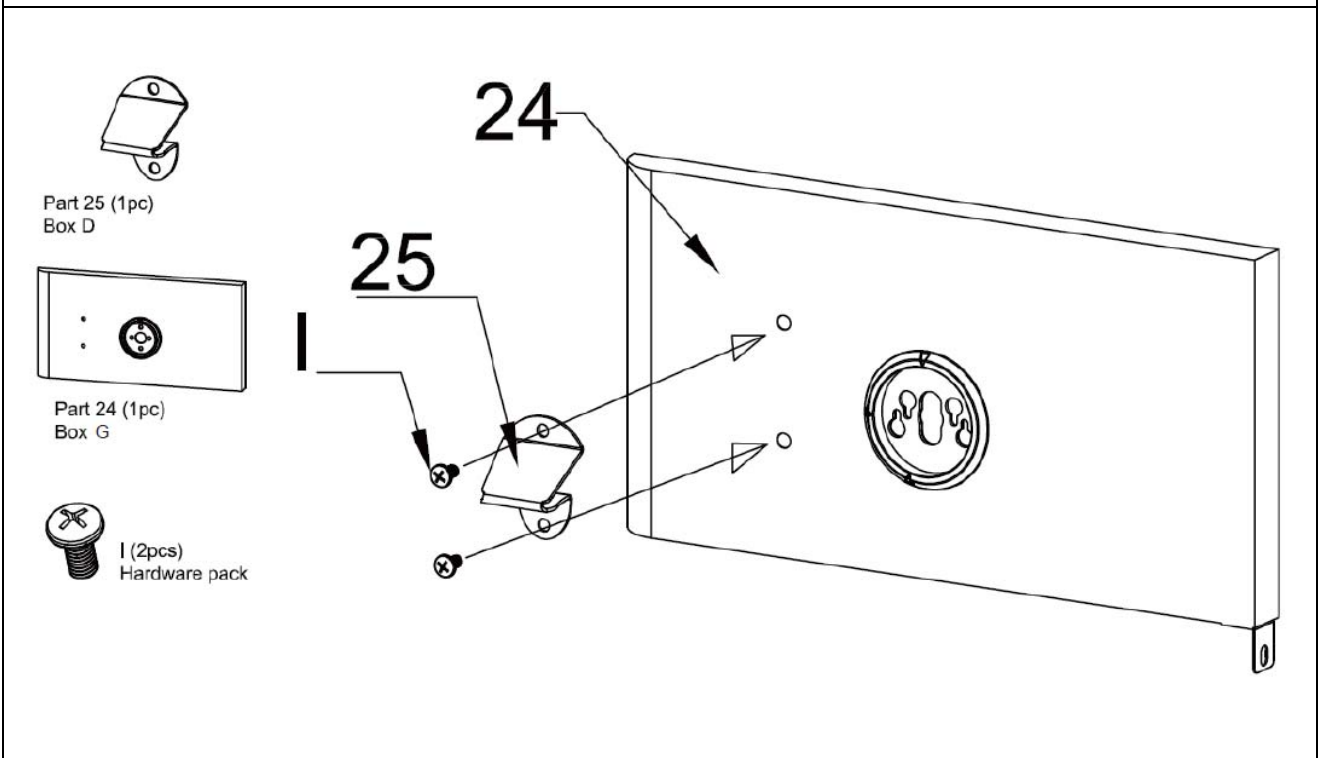

Step 17. Take out the side valve with gas regulator assembly from main control panel at grill side per following shown. Understand the construction of side burner gas components, it would help you proceed the side burner assembly in next several steps.

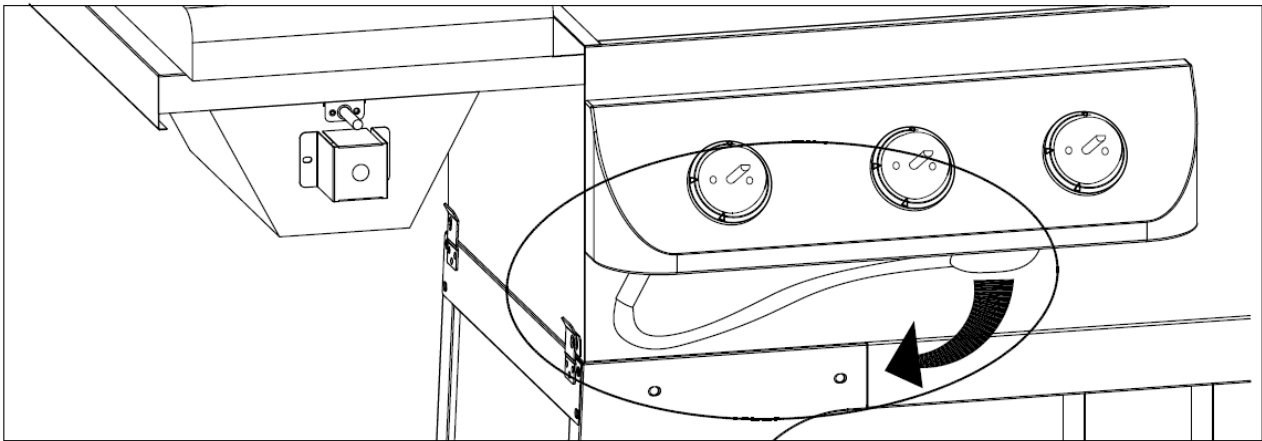

Construction of Side burner gas components

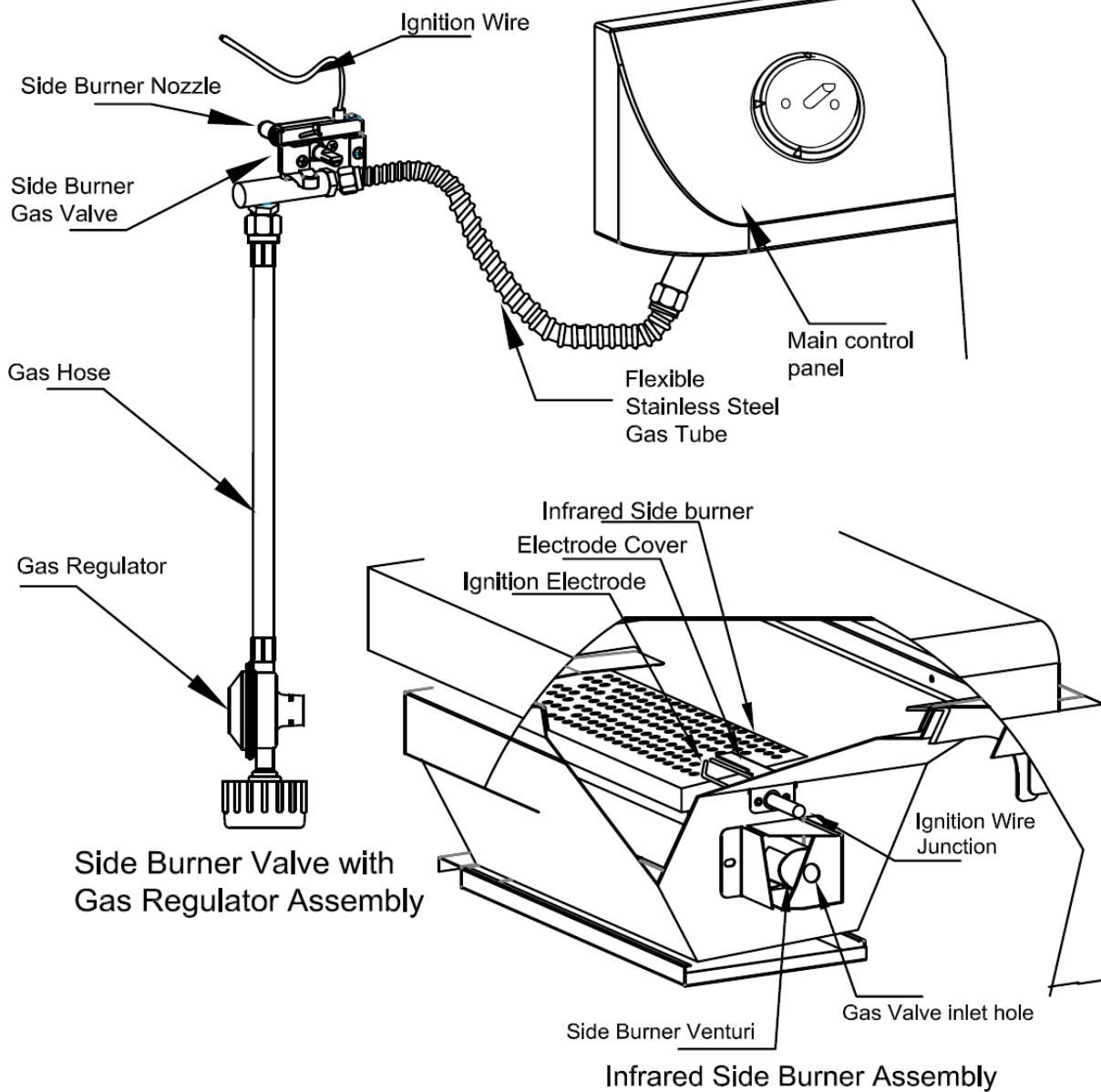

Step 18: ATTENTION: DO NOT OVER TWISTING THE FLEXIBLE STAINLESS STEEL GAS TUBE

GENTLY bend the Flexible Stainless Steel Gas Tube its route is similar to illustration (a).
Loosen the pre-assemble screws at Side Burner Gas Valve per illustration (b)

Tips: Do not let the pre-assemble screws get grid of the gas valve. It will help to proceed next step.

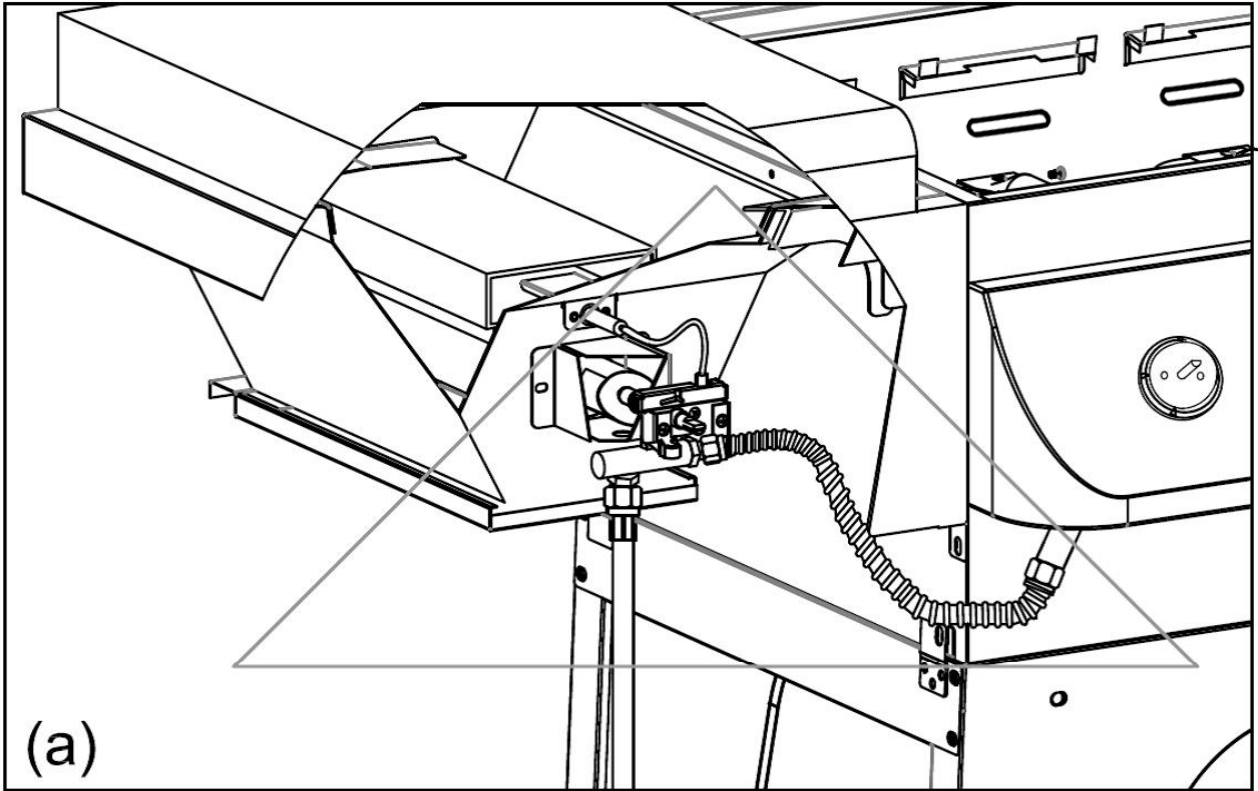

(a)

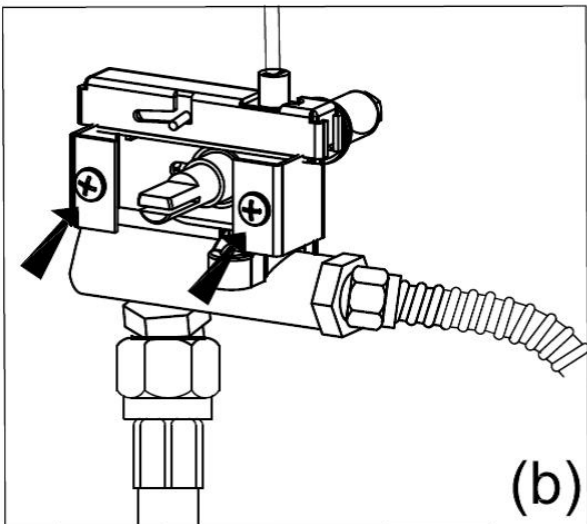

(b)

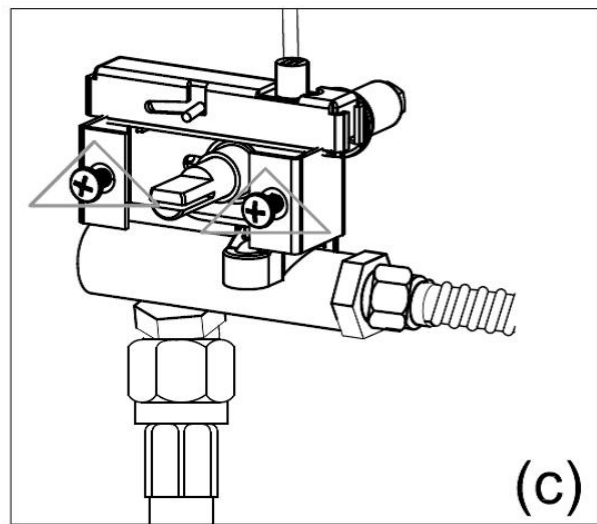

(c)

Step 19: Attach the Side Burner Gas Valve to Side Burner Control Panel per illustration (a) and (b). Before fastening the pre-assembled screws of gas valve, make sure the gas valve should be pushed up at correct position per illustration (c).

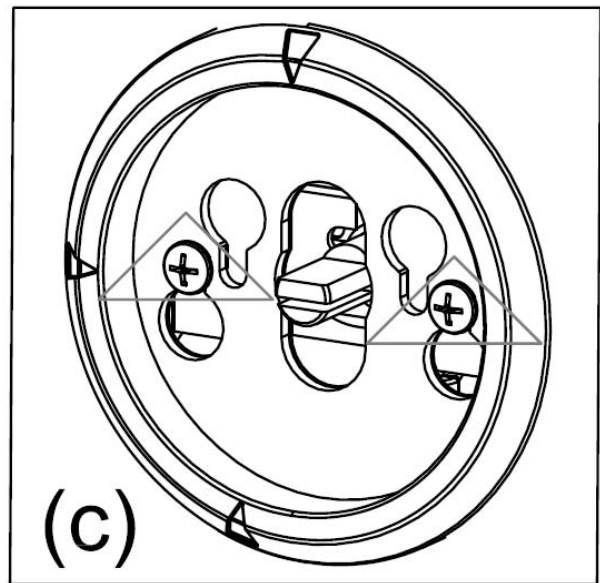
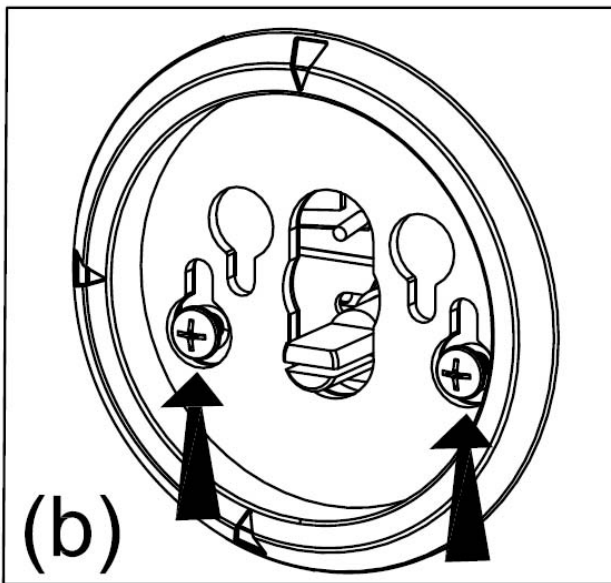
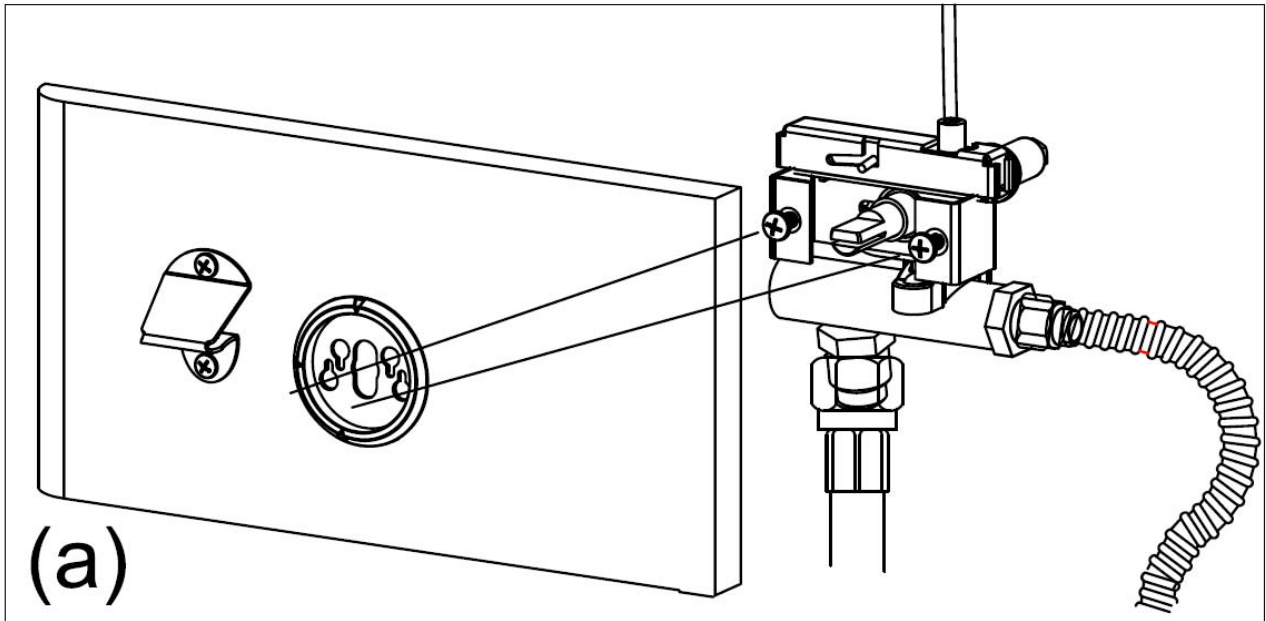

Step20: Connect the Ignition Wire with Ignition Wire Junction first. Attach the Side Burner Control Panel to the Control Panel Bracket. Remember to check that the top lip of the side burner control panel should be hooked onto the side burner control panel brackets. During putting the control panel on the bracket, make sure the Valve Nozzle should be engaged with the Gas Valve Inlet Hole and Side Burner Venturi.

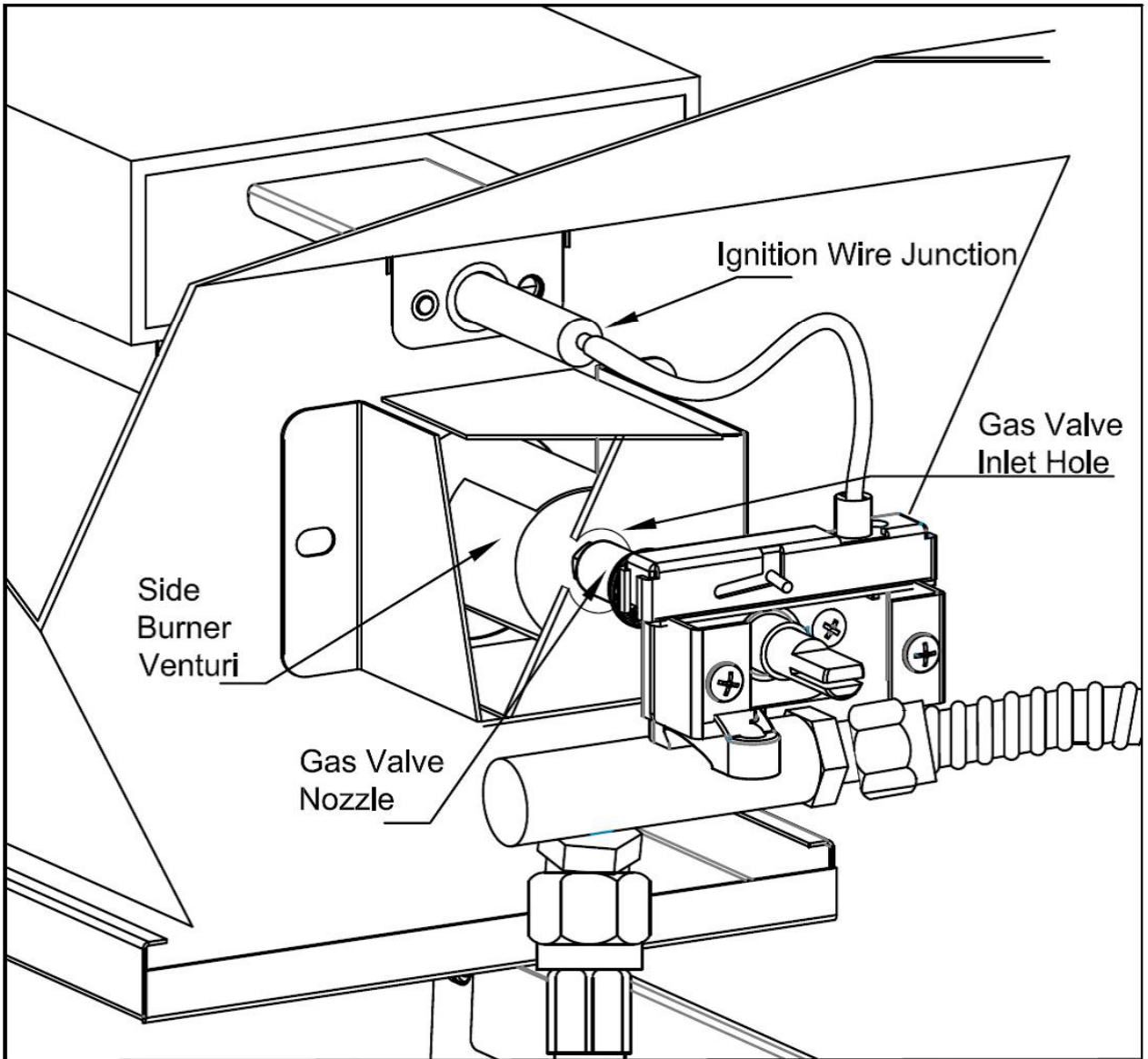
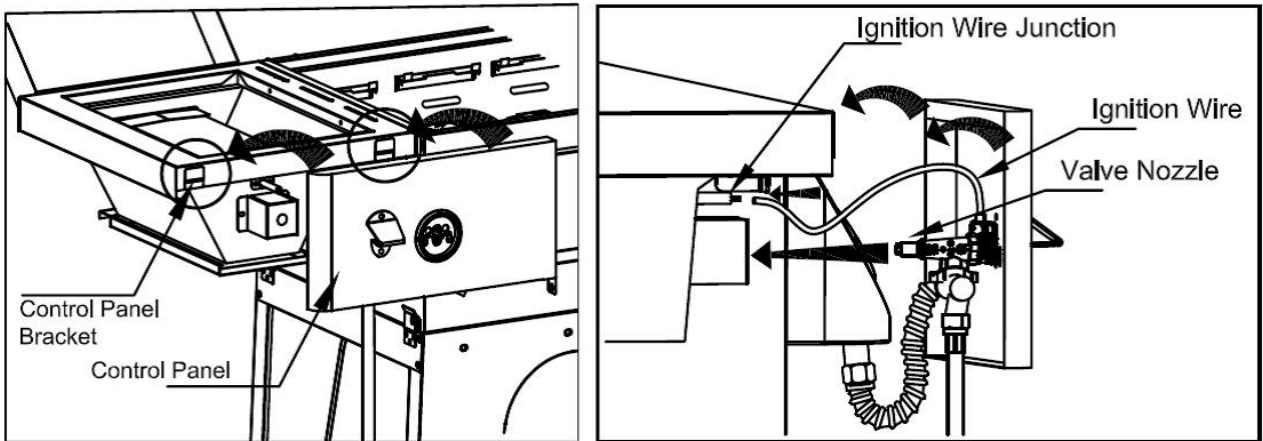

Step 21: Attach the side burner control panel to the side burner per shown. Secure the side burner control panel by using 2 pcs of Bolt (A).

Tips:

Before secure the side burner control panel. Double check following points:

(1) Make sure the Gas Valve Nozzle has already engaged with the Side Burner Venturi. You can see and check through the observation hole at side burner bracket. (Please see the Gray Triangle).

(2) Checking the Ignition wire has already been connected to Ignition Wire Junction. (Please see the Gray Triangle).

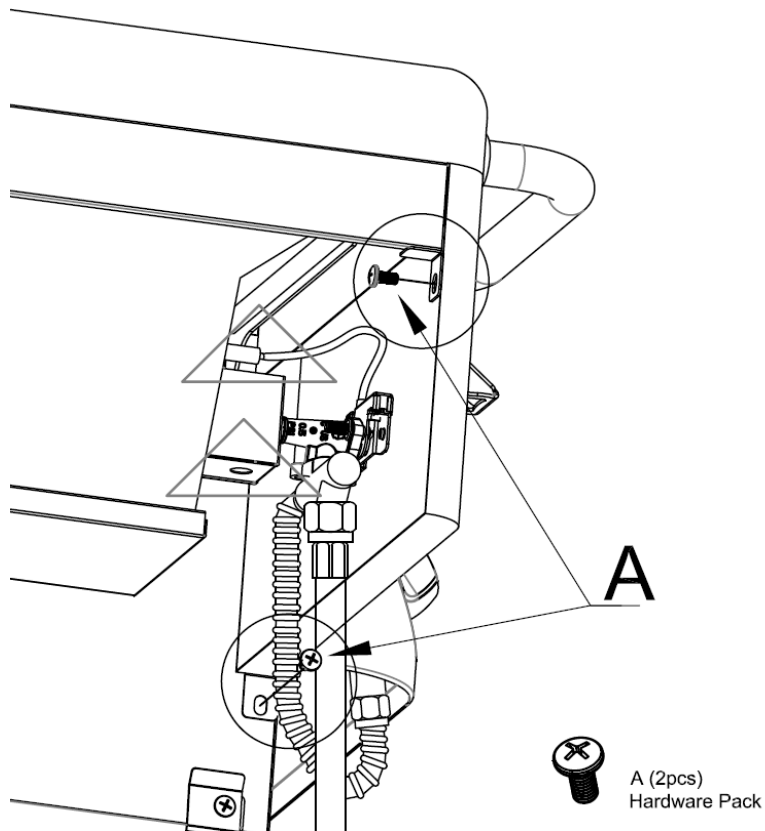

Step 22: Attach the Side Burner Supporting Bar (40) to the side burner and fire box by using 2 pcs of Bolt (A).

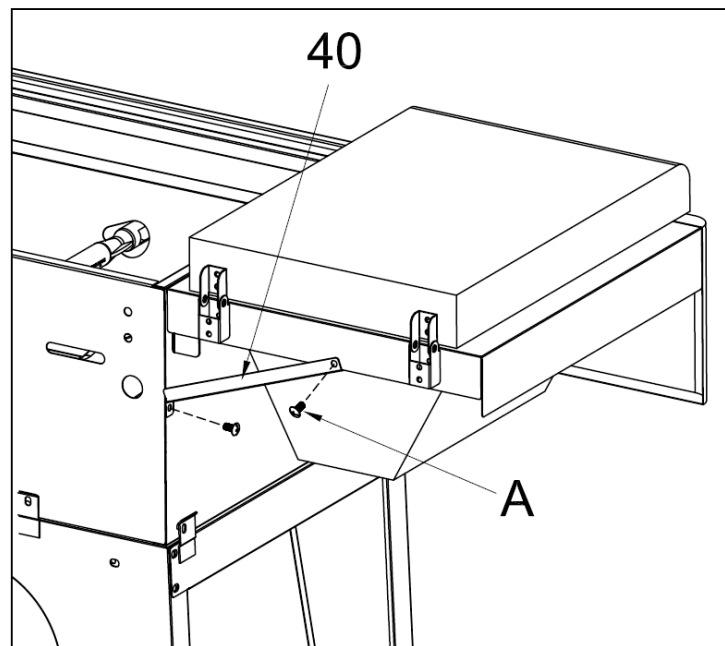
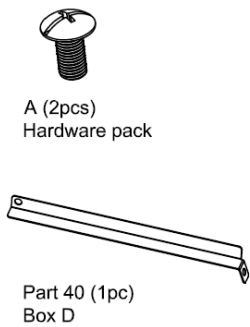

Step 23: Attach the **Control Knobs (26)** to each gas valve.

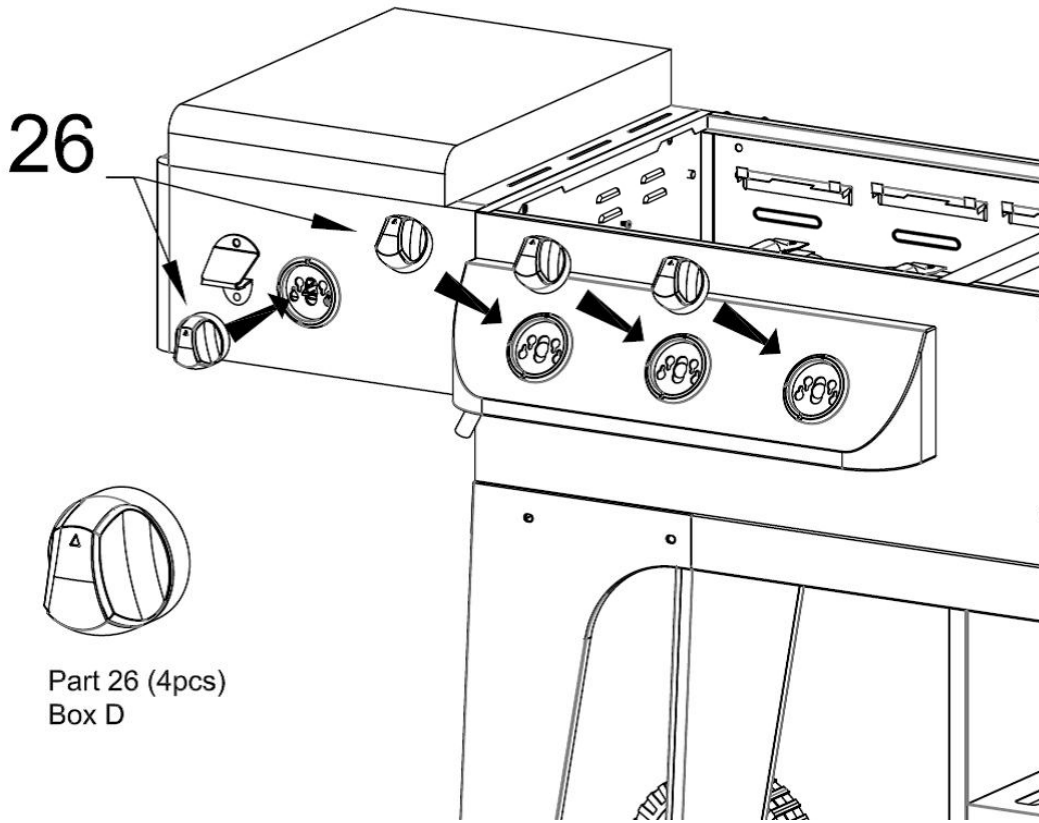

Step 24: Attach the **Lid Handle (8)** and **Bezel (7)** to the side burner lid by using 2 pcs of **Bolt (D)**

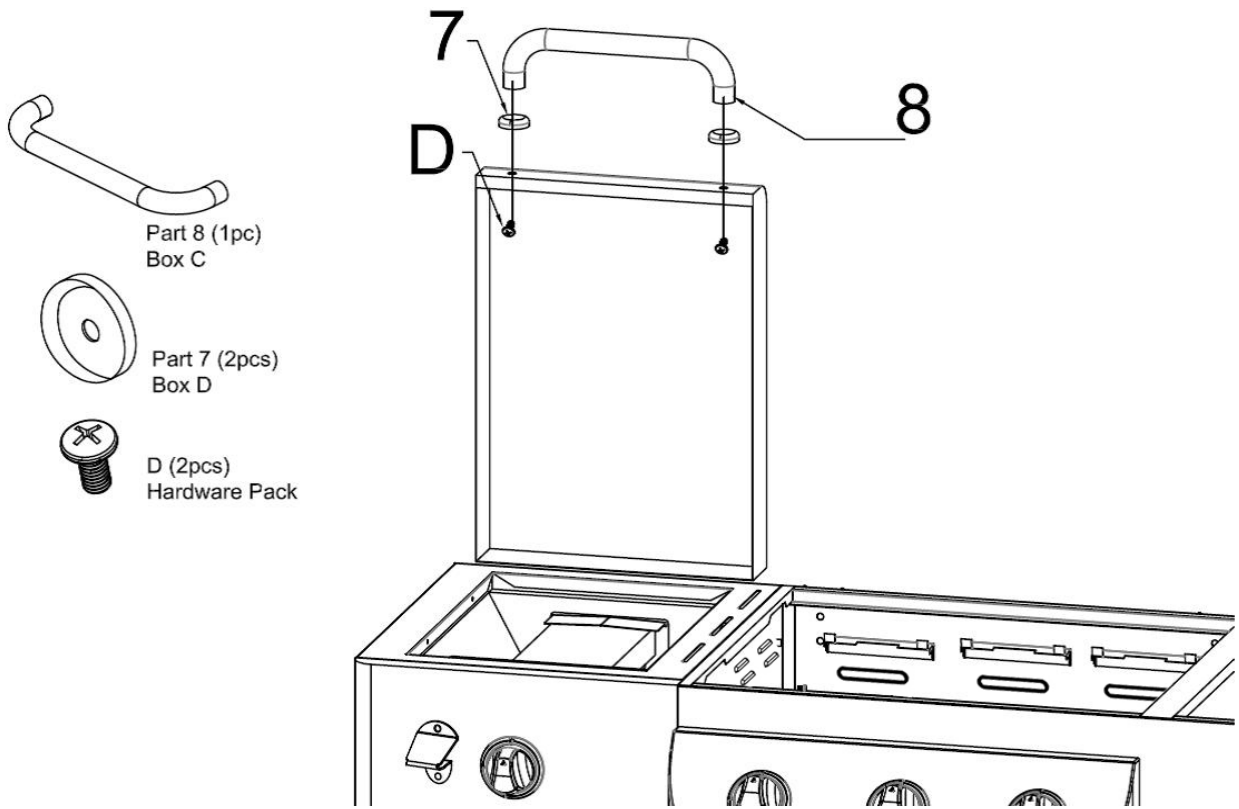

Step 25: Attach **Lid Handle (8)** and **Bezel (7)** to **Right Lid Assembly (19)** and **Left Lid Assembly (3)** by using 4 pcs of **Bolt (F)** respectively. Attach **Upper Hinge (9)** to the **Right Lid Assembly (19)** and **Left Lid Assembly (3)** by using 8 pcs of **Bolt (K)** respectively.

Tips: Remember to check the shape of the hinges and make sure to use the correct hinges for this step. (Please see the grey triangles)

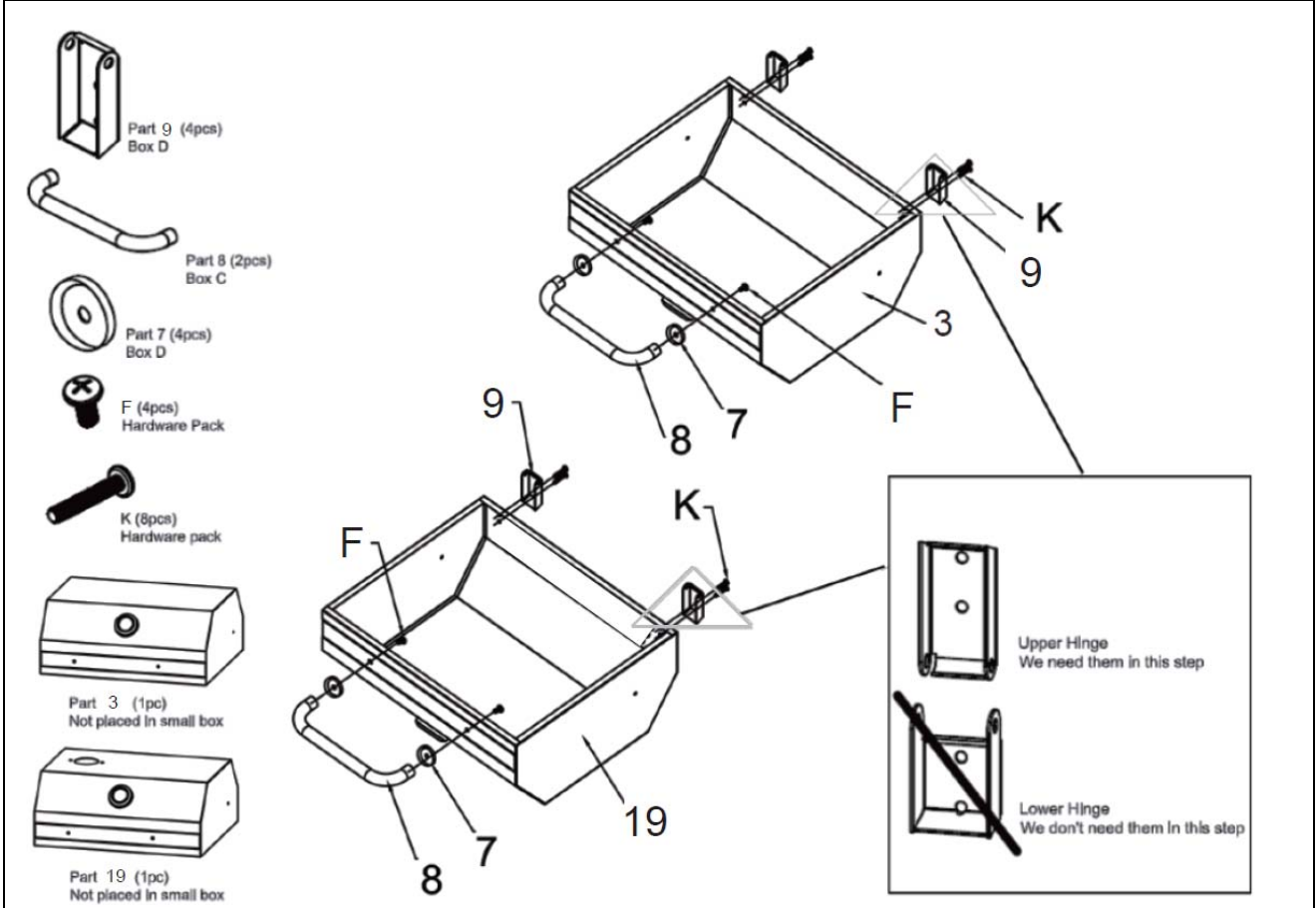

Step 26: Put the **Charcoal Chimney (2)** through the hole of right lid assembly. Secure the charcoal chimney by using 2 pcs of **Bolt (A)**. Attach the **Chimney Cover (1)**, **Spring (M)** to the charcoal chimney by using 1 pcs of **M8 Cap Nut (L)**.

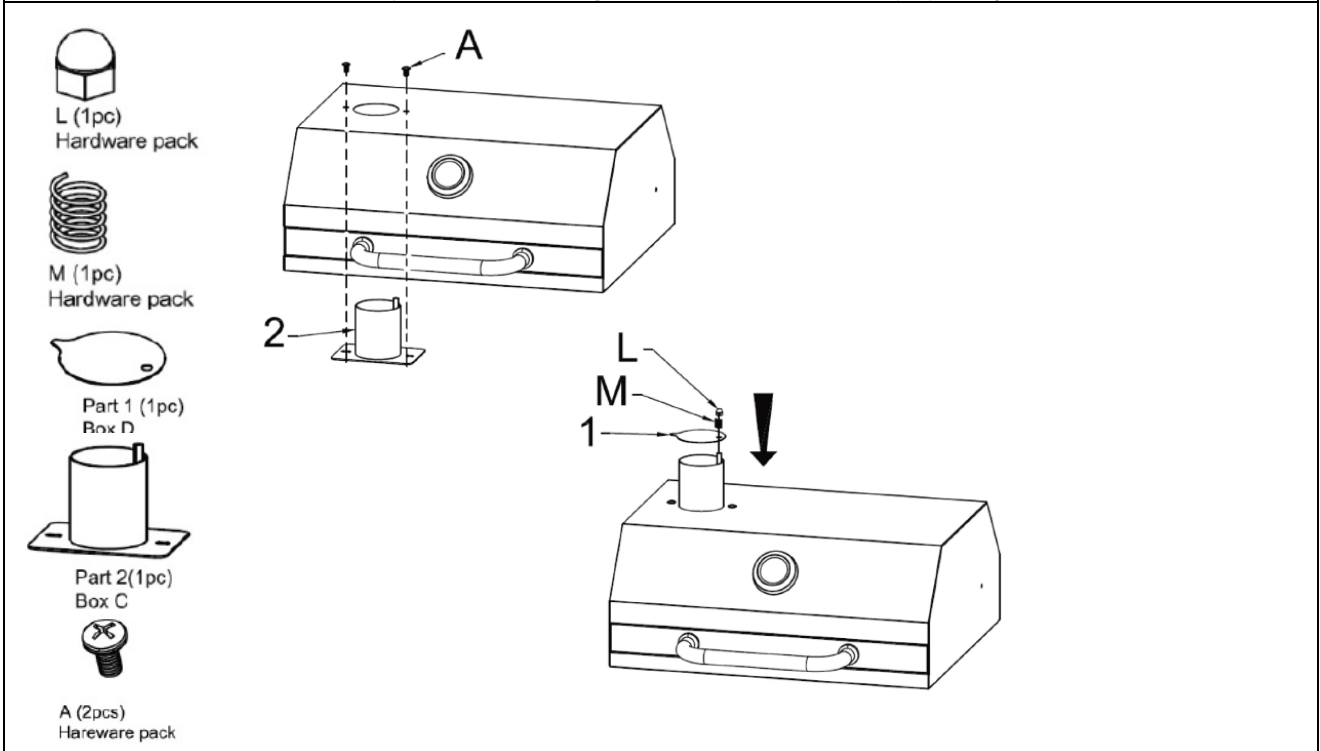

Step27: Attach the **Lower Hinge (10)** to the back of grill body by using 8pcs of **Bolt (K)**.

Tips: Remember to check the shape of the hinges and make sure to use the correct hinges for this step. (Please see the grey triangles)

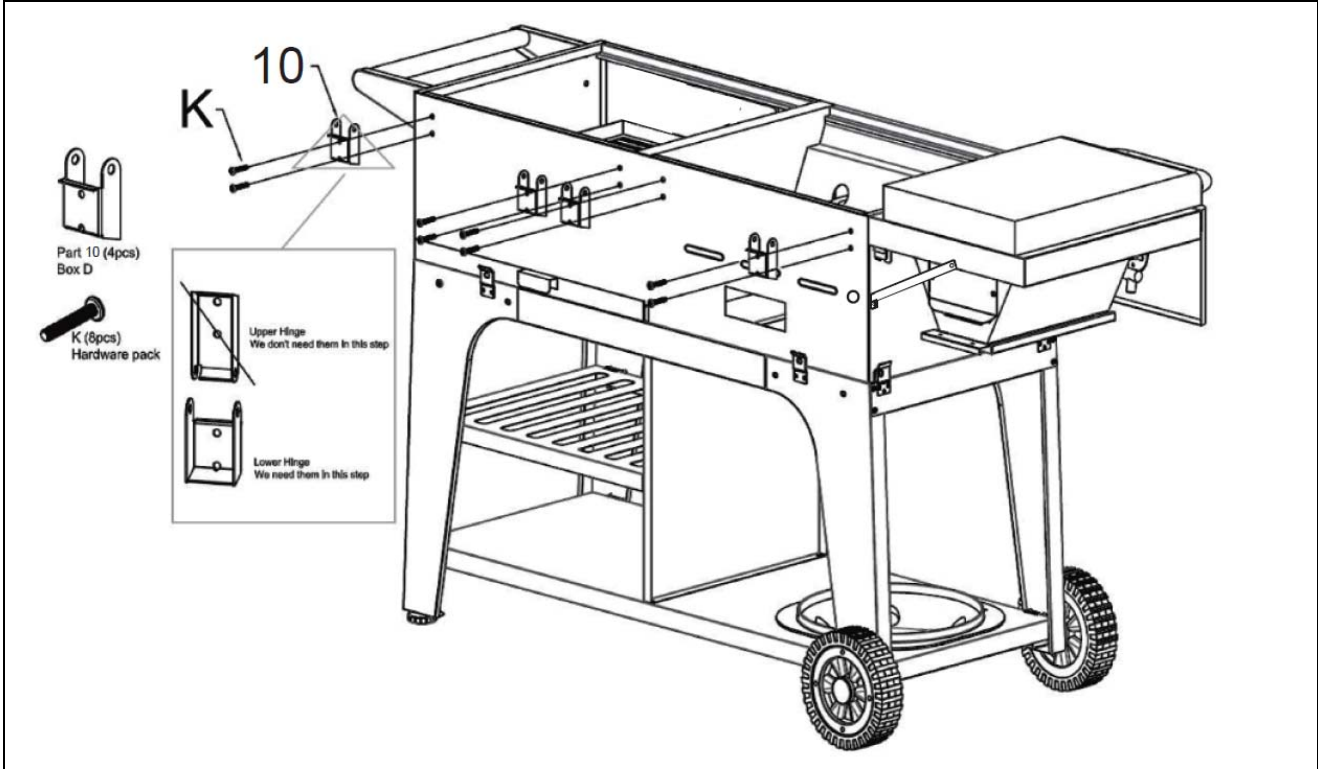

Step 28: Attach the Right and Left Lid on the grill body. The hinges are secured by using 4pcs of **Hinge Pin (N)** and **Cotter Pin (G)** per following shown.

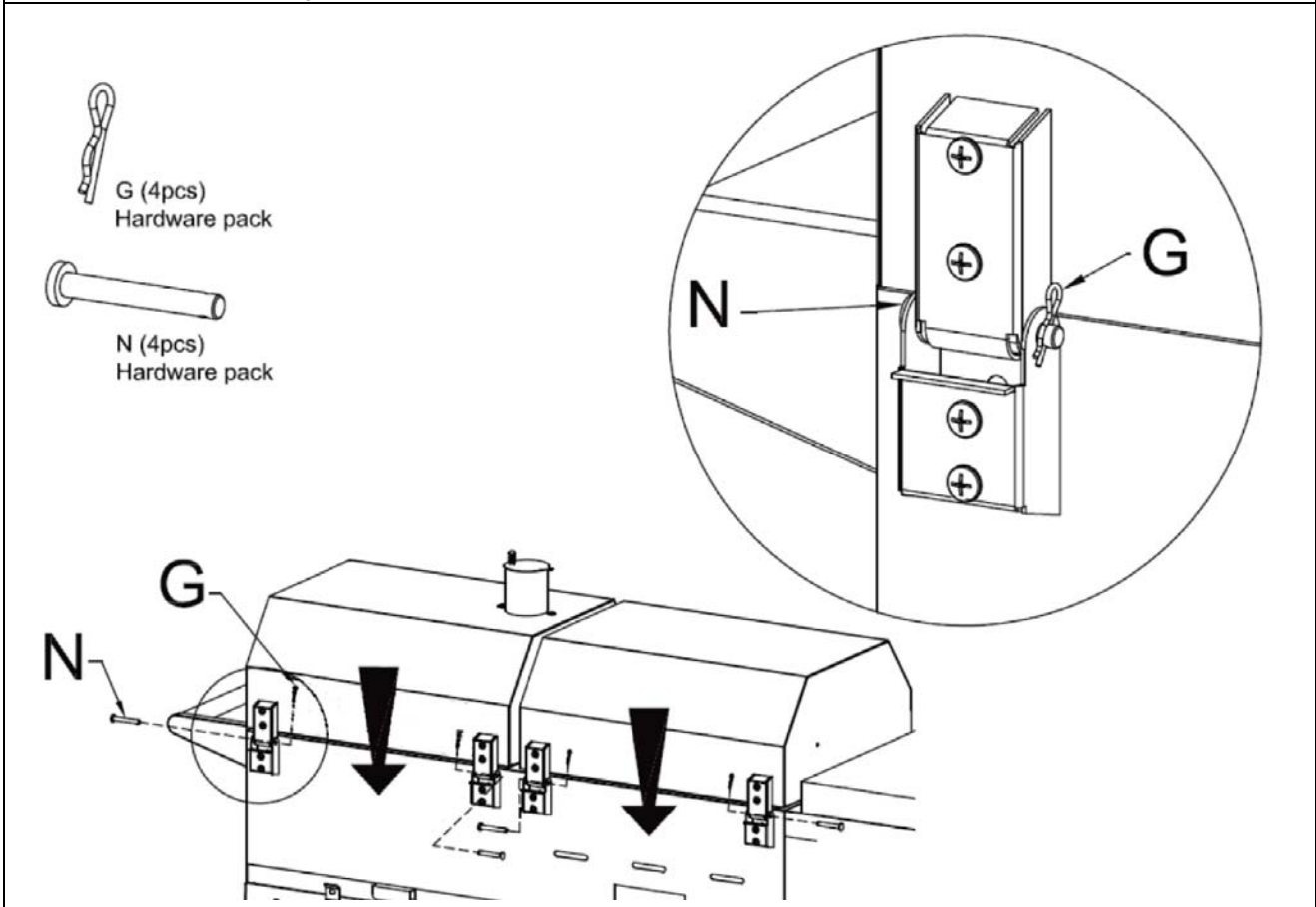

Step 29: Put the **Flame Tamer (13)** over the gas burners first. Then put **Side Burner Cooking Grate (23)**, **Gas Grill Cooking Grate (32)** and **Charcoal Grill Cooking Grate (12)** to the grill body. The **Cooking Grate Lifter (31)** is for lifting up the cooking grates during the cooking.

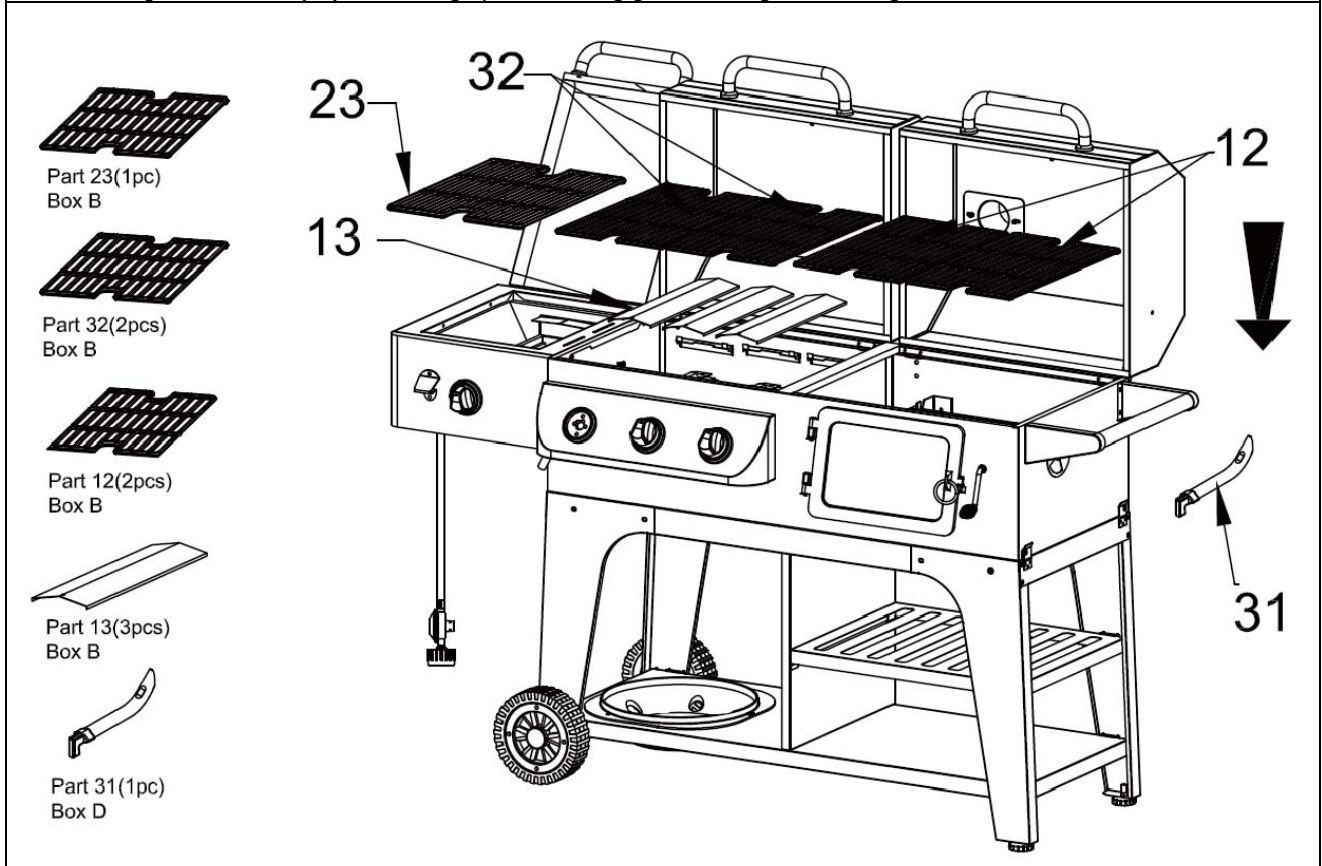

Step 30: Attach the **Warming Rack (11)** to the grill chambers. The top rods of warming rack are inserted into the holes in the lids. The bottom rods of warming rack are inserted into the holes in the grill body. The racks are secured by using 4 pcs of **Cotter Pin (G)**.

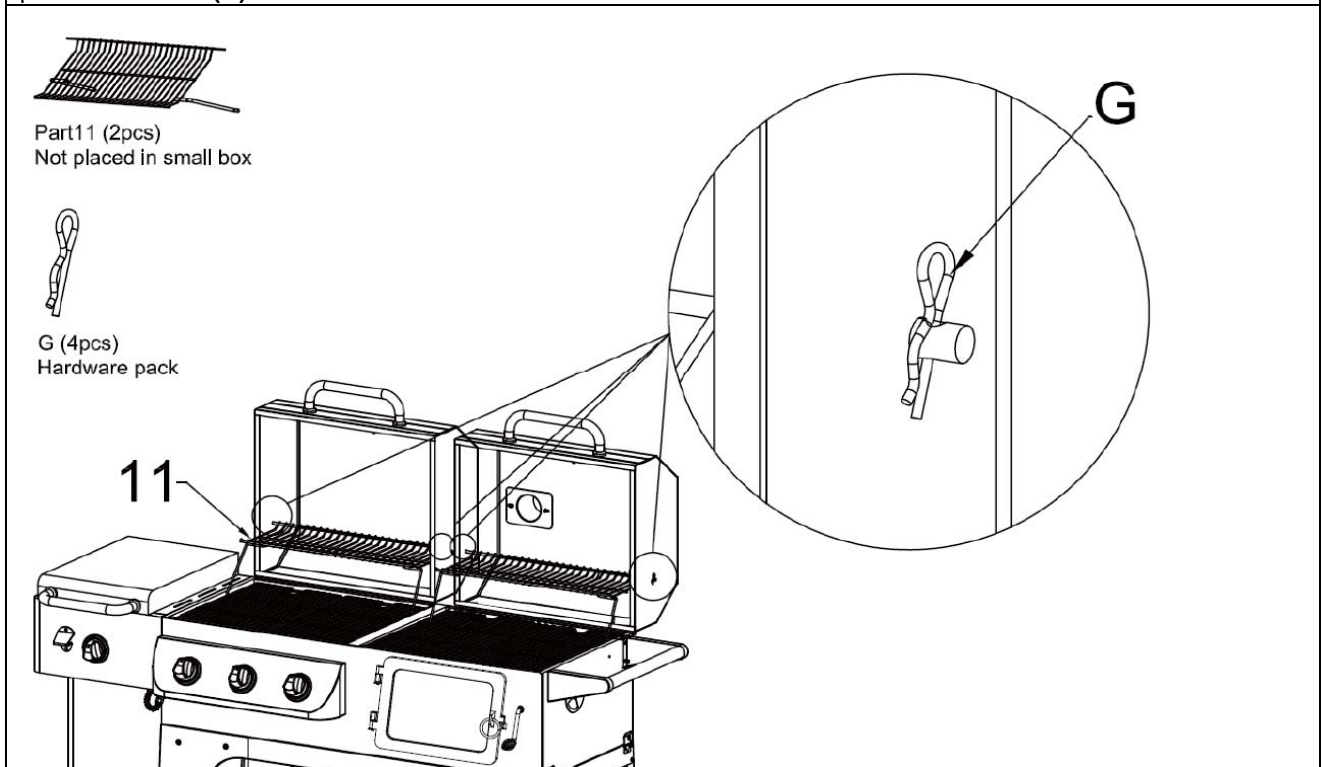

Step31: Take out the grease tray from the grill body. Attach **Charcoal Grease Tray Handle (29)** by using 2 pcs **Bolt (A)**. Also put the **Grease Cup (30)** to the Grill body as shown.

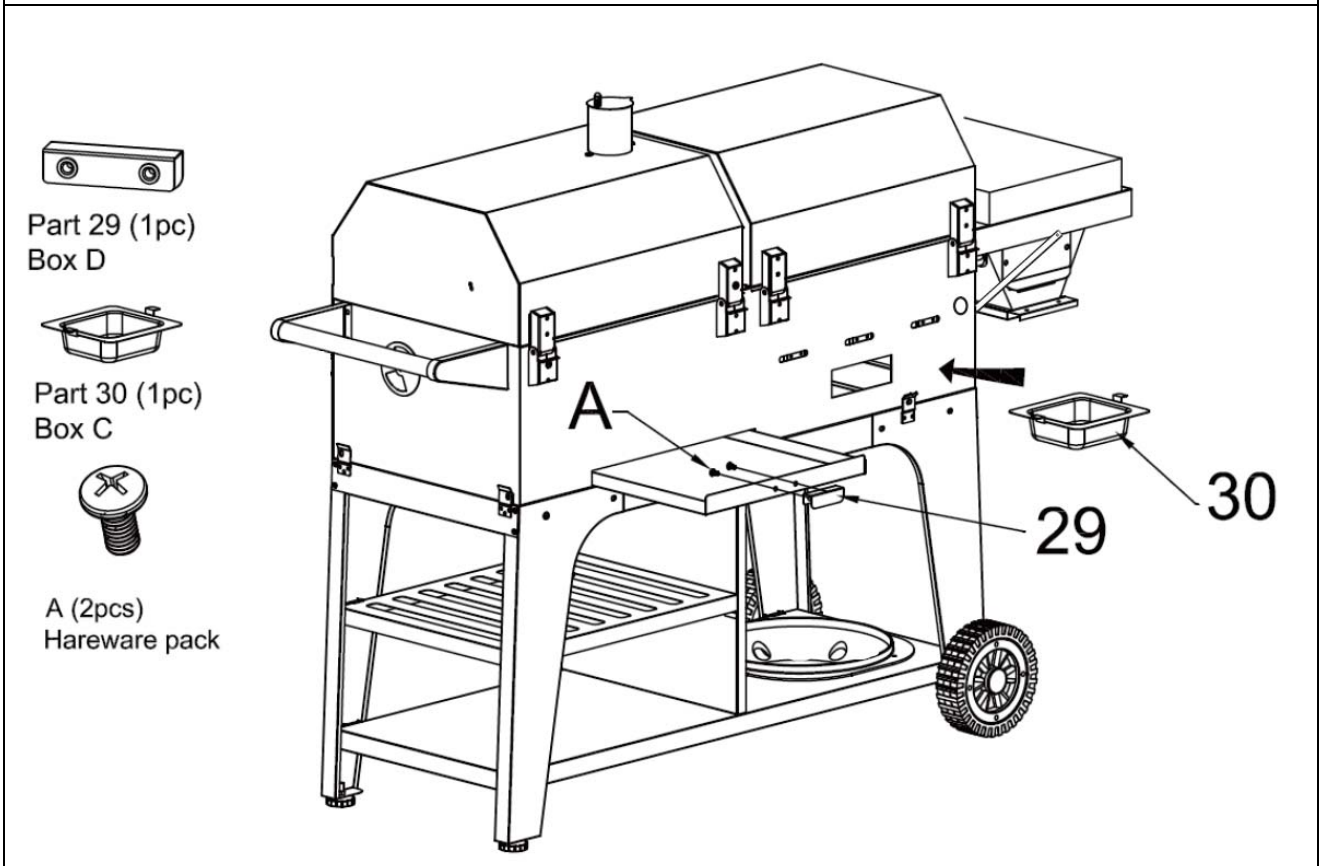

Assemble Completed

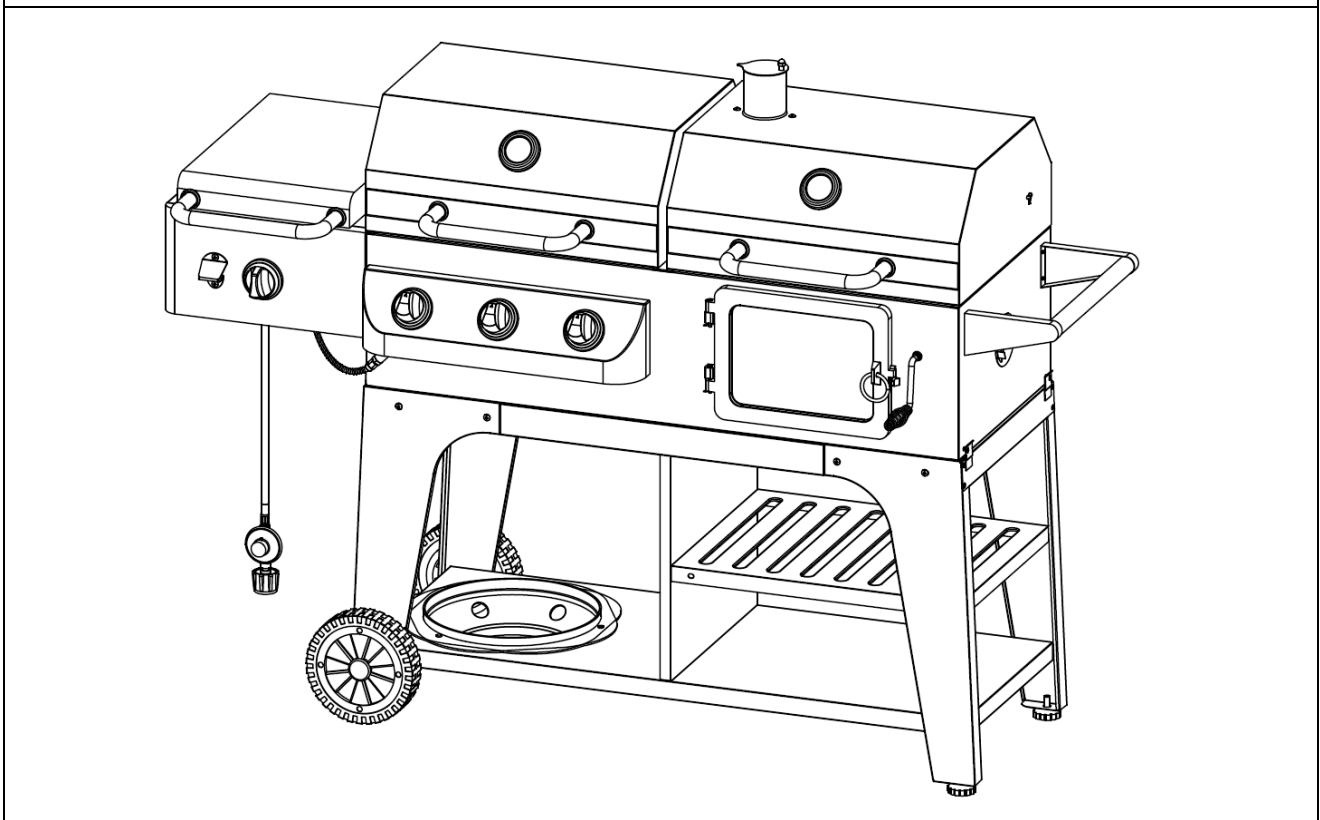

Troubleshooting

Problem	Possible Cause	Prevention / Cure
Burner will not light using "Ignition Burner".	<ol style="list-style-type: none"> 1. Wire/or electrode covered with cooking residue. 2. Electrode and burner are wet. 3. Electrode cracked or broken – sparks at crack 4. Ignitor wire loose or disconnected 	<ol style="list-style-type: none"> 1. Clean wire and/or electrode, with rubbing alcohol. 2. Wipe dry with cloth. 3. Call customer Service to replace electrode. 4. Reconnect ignitor or replace electrode/wire assembly.
Main burner cannot light.	<ol style="list-style-type: none"> 1. No gas flow 2. Coupling nut and regulator not connected. 3. Obstruction of gas flow. 4. Dis-engagement of burner to valve. 5. Spider webs or insect nest in venturi (burner insert). 6. Burner ports clogged or blocked. 	<ol style="list-style-type: none"> 1. Check if propane tank is empty. If propane tank is not empty, refer to "Sudden drop in gas flow or reduced flame height". If empty, replace the tank. 2. Turn the coupling nut about one-half fully connected to three quarters additional turn until solid stop. Tighten by hand only- do not use tools. 3. Clear burner tubes. Check for bent or kinked hose. 4. Re-engage burner and valve. 5. Clean venturi. 6. Clean burner ports.
Side burner cannot light.	<ol style="list-style-type: none"> 1. No gas flow 2. Coupling nut and regulator not connected. 3. Obstruction of gas flow. 4. Dis-engagement of burner to valve. 5. Spider webs or insect nest in venturi (burner insert). 6. Burner ports clogged or blocked 	<ol style="list-style-type: none"> 1. Check if propane tank is empty. If propane tank is not empty, refer to "Sudden drop in gas flow or reduced flame height". If empty, replace the tank. 2. Turn the coupling nut about one-half fully connected to three quarters additional turn until solid stop. Tighten by hand only- do not use tools. 3. Clear burner tubes. Check for bent or kinked hose. 4. Re-engage burner and valve per assembly procedure. Clean venturi. 5. Clean burner ports.
Sudden drop in gas flow or reduced flame height.	<ol style="list-style-type: none"> 1. Out of gas. 2. Excess flow safety device may have been activated. 	<ol style="list-style-type: none"> 1. Change Propane Tank. 2. Turn off knobs, wait 30 second and light the grill. If flames are still low. Reset the excessive flow safety device by turning off knobs and propane tank valve. Disconnect regulator. Turn burner control knobs to HI. Wait 30 seconds and then light grill.
Irregular flame pattern, flame does not run the full length of burner.	<ol style="list-style-type: none"> 1. Burner ports are clogged or blocked. 	<ol style="list-style-type: none"> 1. Clean burner ports.
Flame is yellow or orange.	<ol style="list-style-type: none"> 1. New burner may have residual production oil. 	<ol style="list-style-type: none"> 1. Burn grill for 15 minutes with the lid closed.
Flame blows out.	<ol style="list-style-type: none"> 1. High or gusting winds. 2. Low gas pressure. 3. Excess flow valve tripped. 	<ol style="list-style-type: none"> 1. Turn front of grill to face wind or increase flame height. We highly recommend not to use the grill during high winds.) 2. Change Propane Tank. 3. Refer to "Sudden drop in gas flow or reduced flame height".
Flare-up	<ol style="list-style-type: none"> 1. Grease buildup. 2. Excessive fat in meat. 3. Excessive cooking temperature. 	<ol style="list-style-type: none"> 1. Clean grill. 2. Trim fat meat before grilling. 3. Adjust (lower) temperature accordingly.
Flashback (Fire in burner tube)	<ol style="list-style-type: none"> 1. Burner and/or burner tubes 	<ol style="list-style-type: none"> 1. Clean burner and/or burner tubes.

We would like to hear from you with any comments or suggestions. In the continental U.S or Canada, you can call us toll-free at 1.888.301.0332 from 8 a.m. to 5 p.m. CST Monday – Friday. You can also send us an email using the feedback icon at SamsClub.com. Call center for missing parts 1.888.837.1380

LIMITED WARRANTY

1. Manufacturer warrants this Product to be free from defects in workmanship and materials for a period of Ninety (90) days from the date of purchase, PROVIDED claims are submitted, in writing, with proof of purchase.
2. If any part of this item fails because of a manufacturing defect within the Limited Warranty Period, Manufacturer offers to replace such part(s) provide that such parts have not been improperly repaired, altered, or tampered with or subject to misuse, abuse or exposed to corrosive conditions. This Limited Warranty is, however, subject to certain limitations, exclusions, time limits and exceptions (Hereinafter "Conditions") as listed below. Read these Conditions carefully.
3. This Limited Warranty shall be limited to the replacement or repair of any part(s) which Manufacturer determines, after reasonable examination, to have been defective at the time of manufacturing and manufacturer's obligation(s) shall be limited to replacement, if any, of defective part(s) which shall be shipped at Original Purchaser's expense to Original Purchaser's designated shipping address.
4. This Limited Warranty is given to and covers the **ORIGINAL PURCHASER ONLY** and such coverage terminates Ninety (90) days from the date of purchase.
5. **DAMAGE LIMITATION WARNING:** IN NO EVENT SHALL MANUFACTURER BE LIABLE FOR ANY INCIDENTAL OR CONSEQUENTIAL DAMAGES, INCLUDING (BUT NOT LIMITED TO) LOSS OF USE OF THE PRODUCT, LOSS OF TIME, LOSS OF FOOD, INCONVENIENCE, EXPENSES FOR TRAVEL, TRANSPORTATION LODGING EXPENSES, LOSS BY DAMAGE TO PERSONAL PROPERTY OR LOSS OF INCOME, PROFITS OR REVENUE.
6. **MANUFACTURER'S OBLIGATION:** Manufacturer's liability shall be limited to the delivery of a good, merchantable Product and, if necessary, the repair or replacement, at manufacturer's option, of any defective part or unit.
7. **TRANSFER LIMITATIONS:** This Limited Warranty is not assignable or transferable. It covers only the original purchaser.
8. **RESERVED RIGHT TO CHANGE:** Manufacturer reserves the right to make changes or improvements to products it produces in the future without imposing on itself any obligations to install the same improvements in the products it has previously manufactured.
9. This Limited Warranty gives the Original Purchaser specific legal rights but there may be other rights which vary by jurisdiction.
10. This warranty does not cover the following items:
 - Chips or scratches on porcelain or painted surfaces.
 - Rust or corrosion is not deemed a manufacturing or materials defect.
 - Discoloration or loss of paint due to handling during assembly, heat or cleaning products. Paint may require touch up.
 - Stainless steel discoloration or corrosion.
 - Consumables such as batteries.

IF CUSTOMER SERVICE BECOME NECESSARY:

1. The Original Purchaser is responsible for shipping and handling charges of the returned item(s) and replacement parts, if any.
2. All parts to be replaced will need to be shipped before replacement items will be sent.
3. Follow the Customer Service Representative's instructions exactly. If a return is necessary, it must be packed carefully and shipped prepaid.

Should you encounter any problem,
CALL US FIRST.
Do not return product to the store.
WE CAN HELP.

For assistance, contact customer service at customerservice@rankam.com
or at (888) 837-1380, Mon to Fri, 8:00am – 5:00pm Pacific Standard time

Manufacturer information

Rankam (China) Manufacturing Company Limited
Address: 18/F., New Lee Wah Centre, 88 Tokwawan Road, Kowloon, Hong Kong.