

This Owner's Manual is provided and hosted by [Appliance Factory Parts](#).



SOLEUSAIR Pmx-08-01 Owner's Manual

[Shop genuine replacement parts for SOLEUSAIR
Pmx-08-01](#)

PRODUCT DIAGRAM

MODEL# PMX-08-01/PMX-10-01

1. Control Panel
2. Manual Control Louver & Air Outlet
3. Carry Handle
4. Casters
5. Air Filter
6. Continuous Drain Port
7. Air Discharge Opening
8. Air Intake Grille
9. Condensation Drain Hole
10. Exhaust Hose
11. Exhaust Hose Connector
12. Window Kit Adapter Grille
13. Window Kit Adapter
14. Optional Window Kit Adapter Extension
15. Window Kit Panels
16. Wing Nuts
17. Optional Drain Tube
18. Drain Tube Stopper
19. Remote Control
20. Batteries
21. Optional Window Security Pack

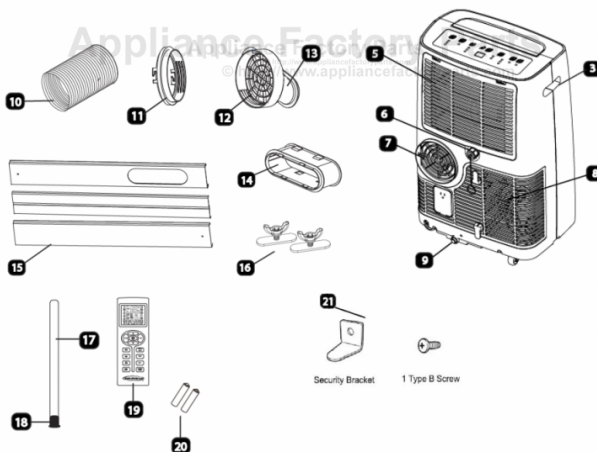

[Find Your SOLEUSAIR Air Conditioner Parts - Select From 74 Models](#)

----- Manual continues below -----



Portable Air Conditioner

8,000 BTU • 10,000 BTU • 12,000 BTU • 14,000 BTU

OPERATING INSTRUCTIONS

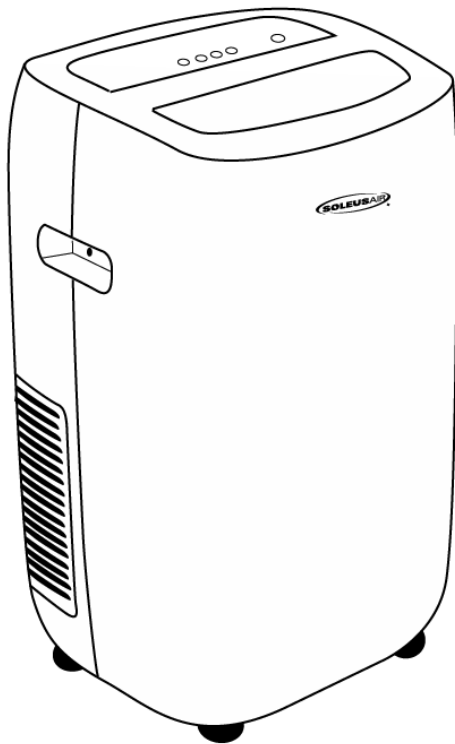

PMX-08-01

PMX-10-01

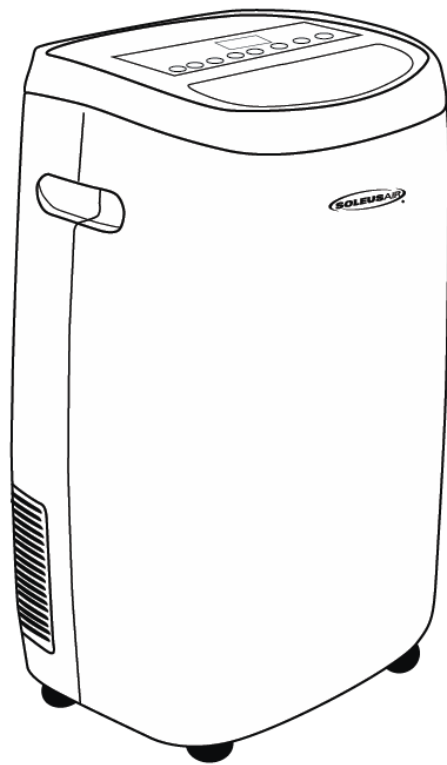

PMC-12-01

PMC-14-01

 **WARNING:** This product can expose you to chemicals including Lead and Bisphenol-A, which are known to the State of California to cause birth defects or other reproductive harm. For more information go to www.P65Warnings.ca.gov

Air conditioner must be upright for 24 hours prior to operating.
This ensures that the compressor will function as intended.



Intertek

3058080

V190404

PURCHASE INFORMATION

Thank you for choosing a Soleus Air Portable Air Conditioner. This Owner's Manual will provide you with valuable information necessary for the proper care and maintenance of your new product. Please take a few moments to thoroughly read the instructions and familiarize yourself with all the operational aspects of your new Soleus Air Portable Air Conditioner.

For your own records, please attach a copy of your sales receipt to this manual. Also, write the store name/location, date purchased, and serial number below:

Store Name: _____

Location: _____

Date Purchased: _____

Serial Number (located on back of unit): _____

IMPORTANT INSTRUCTIONS

Before installing and using your portable air conditioner, please read this owner's manual carefully. Store this manual in a safe place for future reference.

- 1) Always place the unit on a level surface.
- 2) Never use or store gasoline or other flammable vapor or liquid near this unit unless instructed by this manual.
- 3) Maintain at least 10 inches (25 cm) clearance space around this unit. Do not block or cover air inlet or outlet grilles.
- 4) The unit must be connected to a correctly grounded power supply.
- 5) Do not start or stop the unit by inserting or pulling out the power plug.
- 6) Do not use an adapter plug or extension cord.
- 7) Do not use the unit directly by a bathtub, shower or swimming pool.
- 8) Do not insert anything into the air outlet. Do not obstruct air inlet or outlet grills unless instructed by this manual.
- 9) Do not let children play near this unit.
- 10) Always inspect the cord for signs of damage before use. If the power cord is damaged, it must be replaced by the manufacturer or a qualified service technician.
- 11) When cleaning the unit, always turn the unit off and unplug the power cord.
- 12) Do not mix old and new batteries in the remote control.

Do not mix Alkaline, Standard (Carbon - Zinc) or Rechargeable (Nickel - Cadmium) Batteries.



PACKAGE CONTENTS

Portable Air Conditioner (1)
 Exhaust Hose (1)
 Exhaust Hose Connector (1)
 Window Kit Panel (3)
 Window Kit Adapter (1)
 Window Kit Adapter Grille (1)
**8,000 & 10,000 BTU Only*

Optional Window Kit Adapter Extension (1)
 Wing Nut (2)
 Optional Drain Tube (1)
 Drain Tube Stopper (1)
 Remote Control (1)
 AAA Battery (2)
 Owner's Manual (1)
 Optional Window Security Pack (1)

SPECIFICATIONS

Model Number	PMX-08-01	PMX-10-01	PMC-12-01	PMC-14-01
Cooling Capacity	8,000 BTU/Hr	10,000 BTU/Hr	12,000 BTU/Hr	14,000 BTU/Hr
Dehumidification	86 pts/Day	107 pts/Day	120 pts/Day	120 pts/Day
Cooling Power Usage	938 Watts 8.2 Amps	1160 Watts 10.1 Amps	1385 Watts 12 Amps	1545 Watts 13.5 Amps
Air Flow (H/M/L)	176/155/132 CFM	176/155/132 CFM	223/206/188 CFM	241/217/176 CFM
Power Source	115 V / 60 HZ	115 V / 60 HZ	115 V / 60 HZ	115 V / 60 HZ
Noise Level dB(A)	52-54	52-54	53-55	53-55
Product Weight	51.8 Lbs	54 Lbs	65 Lbs	66.1 Lbs
Operating Temperature	61°F -88°F	61°F -88°F	61°F -88°F	61°F -88°F
Product Dimension (W x H x D)	17.125" × 27.125" × 12.375"	17.125" × 27.125" × 12.375"	17.5" × 28.75" × 14.5"	17.5" × 28.75" × 14.5"
Refrigerant	R-410A	R-410A	R-410A	R-410A

- *The cooling capacity is measured at an ambient temperature of DB 95°F, WB 83°F.*
- *Noise level is measured at a distance of 3.28 ft away from the front of the unit, when the unit is in cooling mode.*
- *Power consumption is measured when the fan runs at the highest speed setting.*
- *These specifications are for reference only. For actual data, please refer to the rating label on the back of the unit.*
- *If the environment temperature is higher than the max operating temperature or lower than the minimum operating temperature, the air conditioner may not work properly.*



POWER CORD AND PLUG

This air conditioner is equipped with an LCDI (Leakage Current Detection and Interruption) power cord and plug as required by US National Electric Code 440.65. This cord consists of a length of shielded flexible cord with no termination on the load side and a LCDI attachment plug on the line side.

The LCDI power cord and plug will remove the supply source via electrical disconnect (circuit trip) if the nominal current leakage between the cord shield and either load conductor exceeds a predetermined value. The cord will remain de-energized until the device has been manually reset. This is intended to reduce the risk of a fire in the power cord or combustible materials nearby. The cord shields are not grounded and they must be considered a shock hazard if exposed. The cord shield must not be connected to ground or to any exposed metal.

The test and reset buttons on the LCDI Plug are used to check if the plug is functioning properly. To test:

1. Plug power cord into wall outlet, the LED light will turn on.
2. Press TEST Button, circuit should trip, cutting power to the air conditioner. When this occurs, the LED light will turn off.
3. Press RESET button to restore power to the unit. Once power is restored, the LED light will turn on again.

If test button is pressed and unit can still be turned on, current leakage has been detected. Do not use the air conditioner or attempt to reset the LCDI Plug. Contact Customer Service for troubleshooting recommendations.

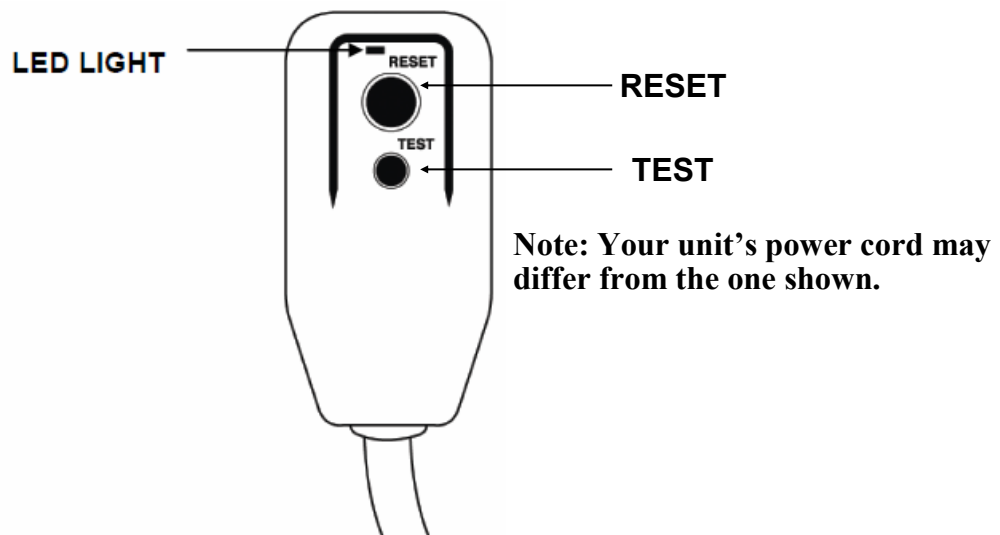

WARNING:

1. DO NOT press the TEST button while the air conditioner is operating.
2. The TEST and RESET buttons should not be used as “ON” and “OFF” switches.
3. The cord and plug are not intended to offer protection to externally connected loads or supply circuits.
4. The cord and plug are intended for indoor use only.



1. Control Panel
2. Manual Control Louver & Air Outlet
3. Carry Handle
4. Casters
5. Air Filter
6. Continuous Drain Port
7. Air Discharge Opening
8. Air Intake Grille
9. Condensation Drain Hole
10. Exhaust Hose
11. Exhaust Hose Connector
12. Window Kit Adapter Grille
13. Window Kit Adapter
14. Optional Window Kit Adapter Extension
15. Window Kit Panels
16. Wing Nuts
17. Optional Drain Tube
18. Drain Tube Stopper
19. Remote Control
20. Batteries
21. Optional Window Security Pack

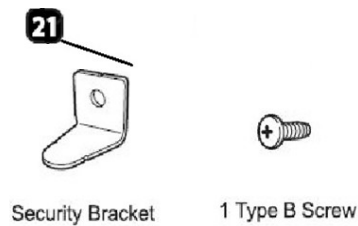
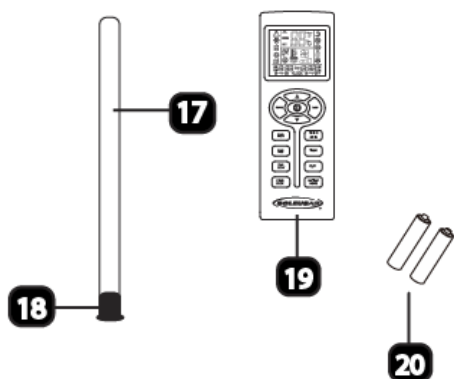
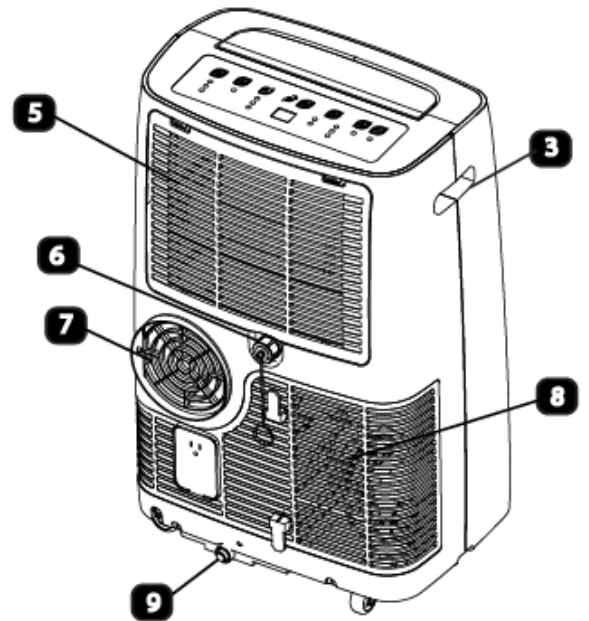
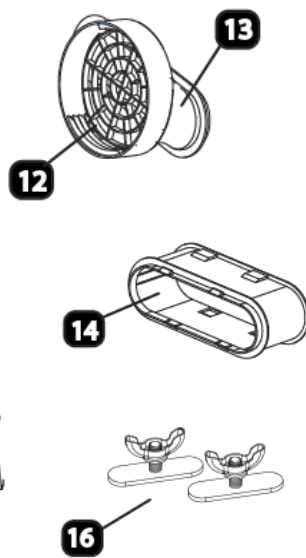
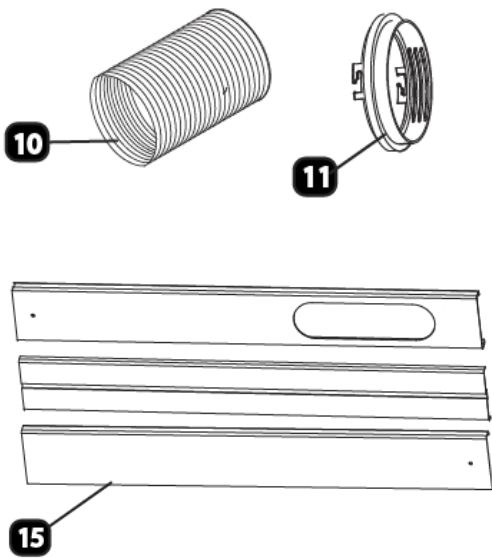

1. Control Panel
2. Manual Control Louver & Air Outlet
3. Carry Handle
4. Casters
5. Air Filter
6. Continuous Drain Port
7. Air Discharge Opening
8. Air Intake Grille
9. Condensation Drain Hole
10. Exhaust Hose
11. Exhaust Hose Connector
12. Window Kit Adapter
13. Window Kit Panels
14. Optional Window Kit Adapter Extension
15. Wing Nuts
16. Drain Tube Stopper
17. Optional Drain Tube
18. Remote Control
19. Batteries
20. Optional Window Security Pack

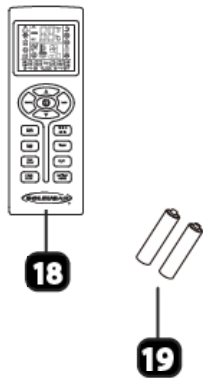
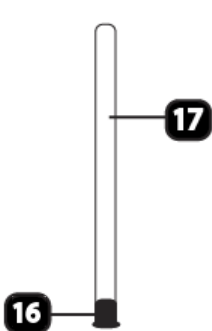
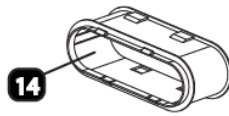
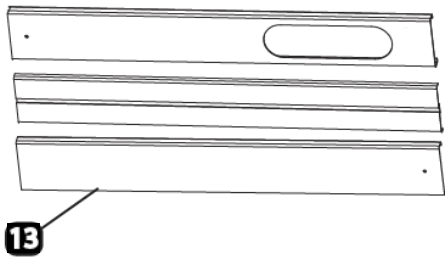
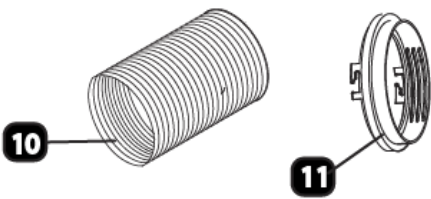
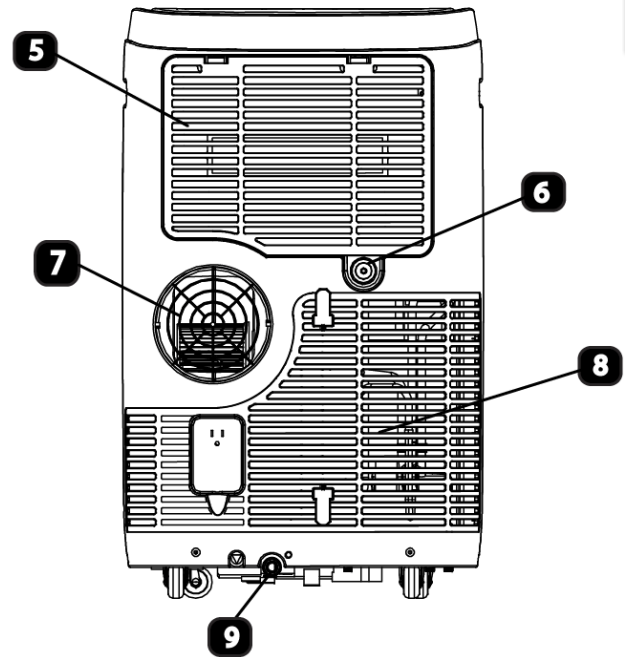
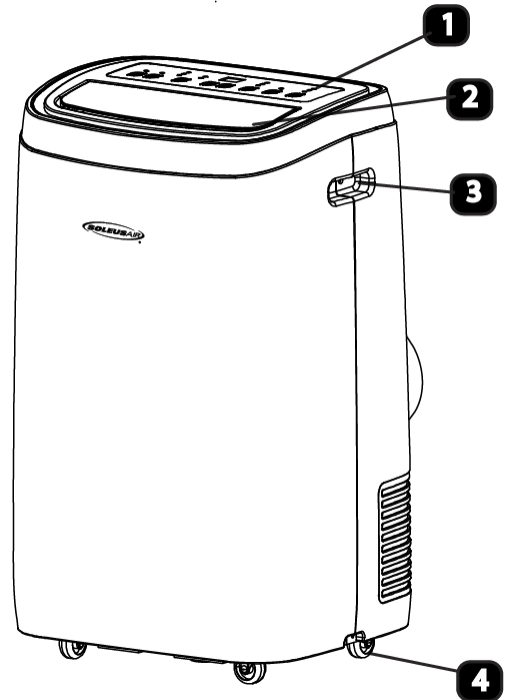

Security Bracket



1 Type B Screw

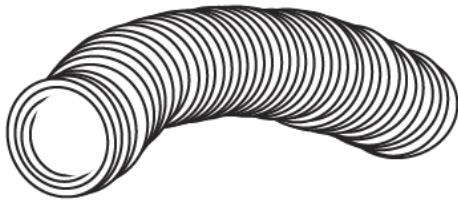

WINDOW VENTING KITExhaust Hose
Connector

Exhaust Hose

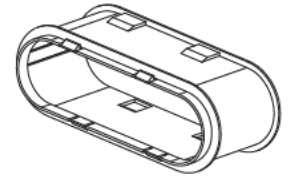
Window Kit Adapter &
Window Kit Adapter Grille
**8,000 & 10,000 BTU Only*Optional Window Kit
Adapter Extension**OPTIONAL WINDOW SECURITY BRACKET**

Security Bracket



1 Type B Screw

ASSEMBLY & INSTALLATION

When the unit is operating in air conditioning mode, the unit draws in indoor air and exhausts hot air out of the room to complete the air exchange. The Window Kit must be installed when operating the unit in air conditioning, dehumidification. When the unit is operating in Fan Mode, no outdoor air exchange takes place. The window kit and exhaust hose do not need to be installed when the unit is used as a fan.

The supplied window kit can be installed in sliding windows and sliding glass doors up to 7 ft. long (approximate length). When installed, be sure to keep the exhaust hose as short and straight as possible for maximum efficiency.



WINDOW KIT ASSEMBLY

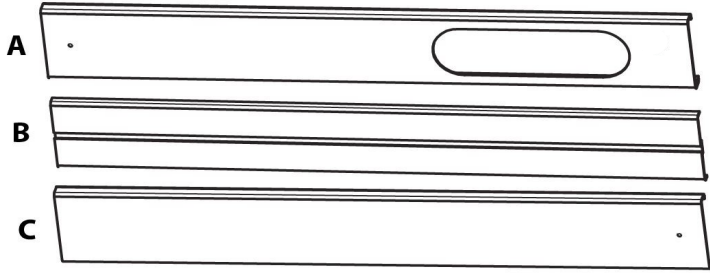

WING NUTS

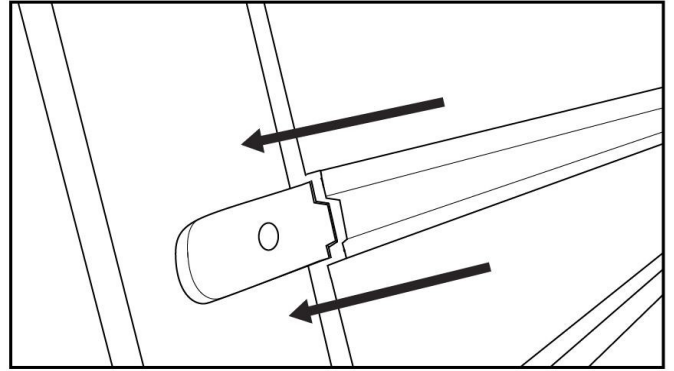

3. Place the Panel B over the Wing Nut Base on Panel C.

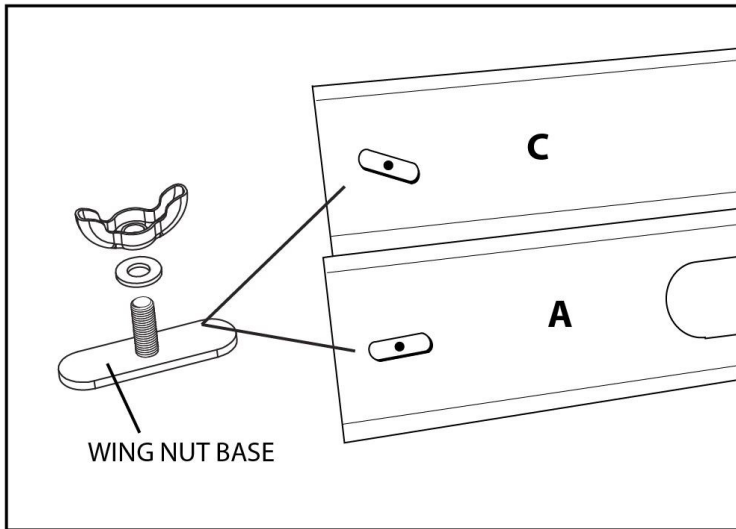

WING NUT BASE

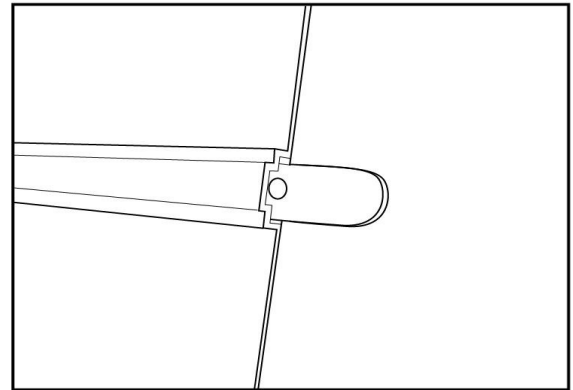

4. Connect Panel A and Panel C by placing the Panel B over the Wing Nut Base on Panel A.

1. Loosen the Wing Nut and the Wing Nut Base, screw Wing Nut into each of the small holes found on the Panel A and Panel C.

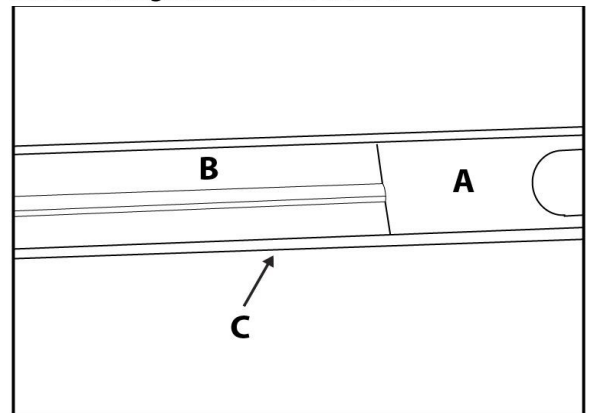

5. The Panel A & C Panel should now be connected using the Panel B.

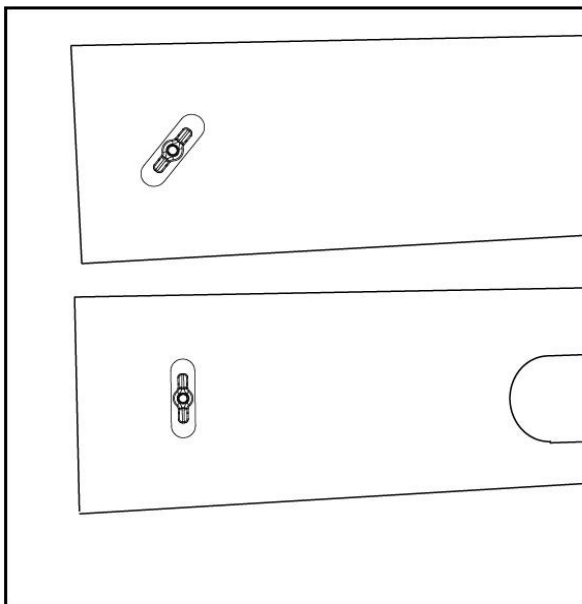

2. Tighten the Wing Nut with Wing Nut Base. **DO NOT** tighten the Wing Nuts all the way; make sure they are somewhat loose.

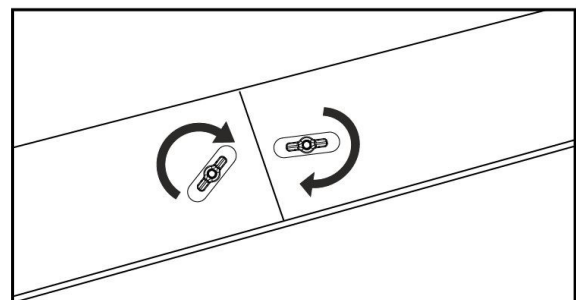

6. To complete the assembly, tighten the Wing Nuts installed earlier.

WINDOW KIT INSTALLATION

PORTABLE AIR CONDITIONER

The window venting kit must be installed in order for the unit to work correctly. The window venting kit has been designed to fit into most vertical and horizontal window openings and sliding glass doors up to 7 feet. *The window kit included with your purchase may vary slightly from what is shown below.

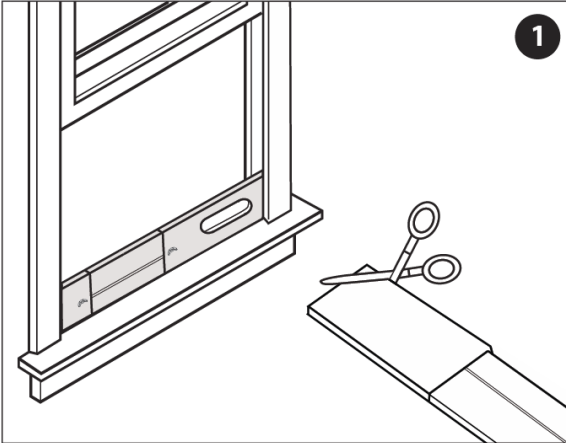

1

1. Open the window or door to adjust the length of the Window Kit Panels to fit the opening. If necessary, mark the kit and cut one end down to properly fit the opening.

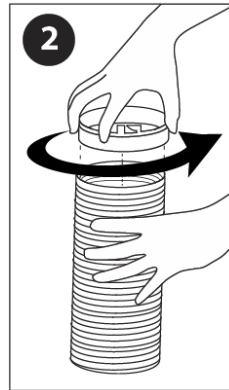

2

2. Twist the Exhaust Hose Connector onto Exhaust Hose.

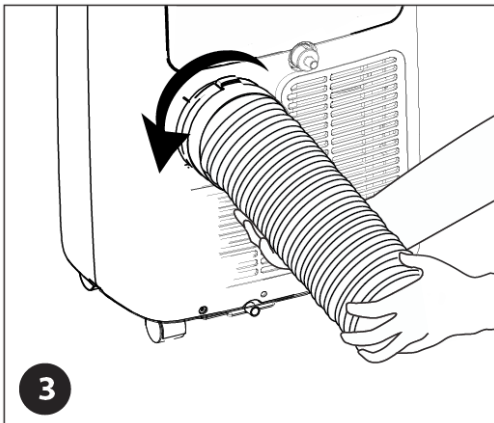

3

3. Twist the Exhaust Hose Connector over the discharge opening on the back of the unit and extend the Exhaust Hose. (Keep the exhaust hose as short and straight as possible)

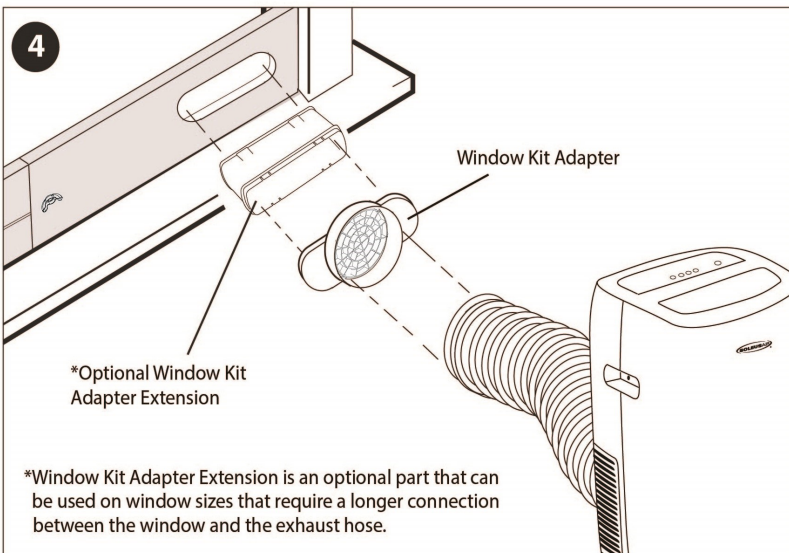

4

4. Attach the Exhaust Hose to the Window Kit Adapter. Now connect the Optional Window Kit Adapter Extension to the Window Kit Adapter. Then attach the Optional Window Kit Adapter Extension to the Window Kit panel. Close the window or door tightly.

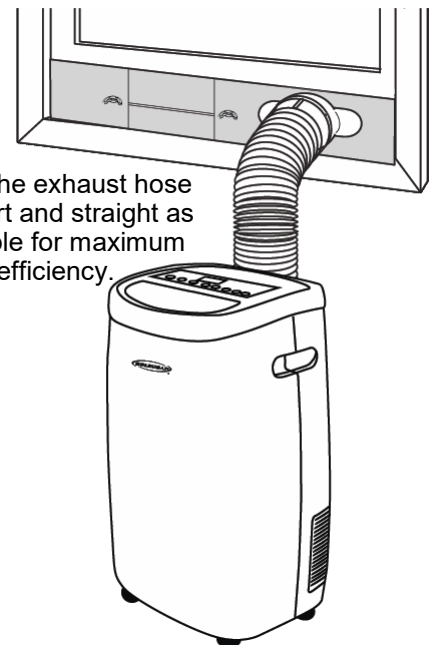

Keep the exhaust hose as short and straight as possible for maximum efficiency.

SECURITY BRACKET

Optional Security Bracket Installation

Your Window Kit also includes an optional security bracket that can be installed to prevent the window from being opened from the outside while a Window Kit is installed.

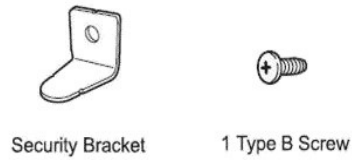

Single and Double Hung Windows

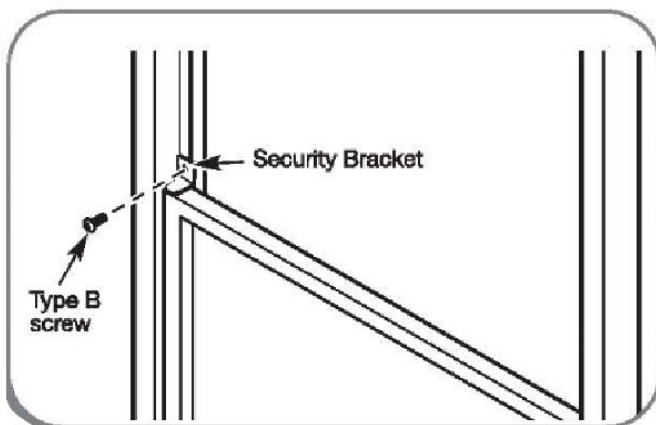

Install the security bracket with a type B screw as shown if you need.

Sliding Windows

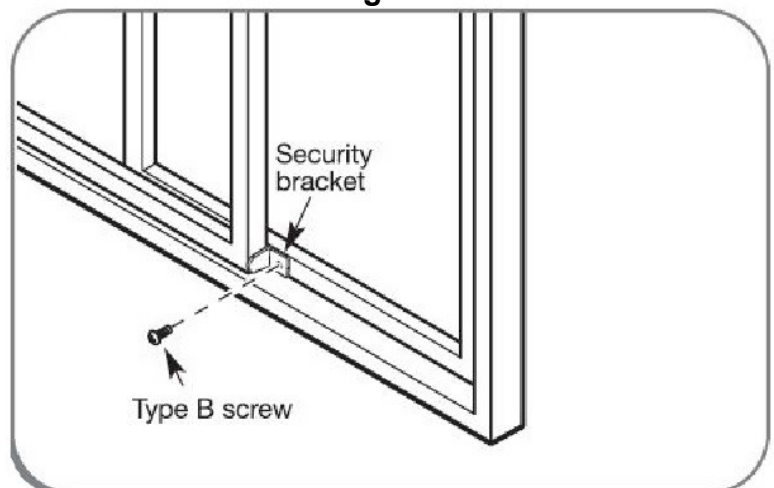

Install the window security bracket with a type B screw as shown.

CONTROL PANEL

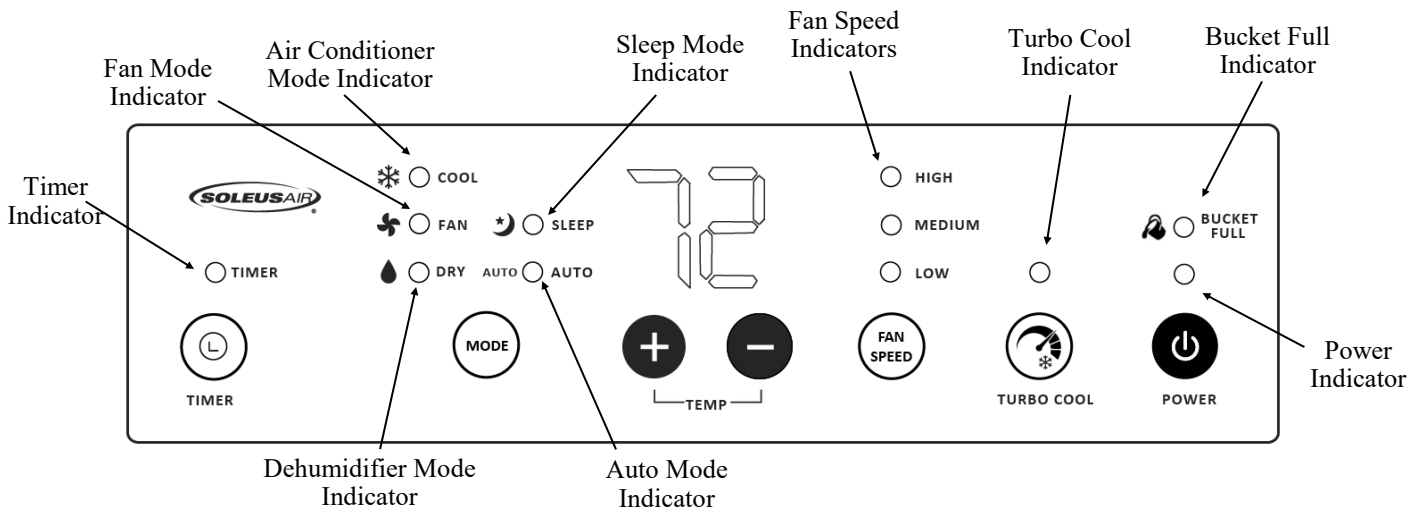

OPERATING INSTRUCTIONS FOR CONTROL PANEL BUTTONS

- 1) **Power On and Off** - Press the **POWER** button once to manually turn the unit on. Press the **POWER** button once more to turn the unit off.
- 2) **Mode Selection** - Press the **MODE** Button repeatedly to cycle between the different modes: Air Conditioner (Cool) mode, Fan-only mode, Dehumidifier (Dry) mode, Sleep mode, and Auto mode. Each press of the MODE button will light up a different indicator on the control panel. The exhaust hose and window kit must be installed when the unit is in Air Conditioner, Dehumidifier mode, Auto mode, and Sleep mode. When using the unit as a fan, the window kit is not required.
- 3) **Temperature** - Select the desired temperature by pressing either the + or - button when using the unit in Air Conditioner mode. The temperature indicator flashes to display the desired temperature setting. After the temperature is set, the unit will display this temperature setting until it is changed by the user. The temperature indicator display shows temperature in Fahrenheit. While the unit is plugged in, but not powered on, press and hold the + and - buttons for 3 seconds to switch between Celsius and Fahrenheit.
- 4) **Fan Speed** - Press **FAN SPEED** button to choose fan speed in High, Medium or Low.
- 5) **Timer** - Press **TIMER** button to set the unit automatically turn ON or OFF. Use the + and - buttons to program the hour increment.
- 6) **Turbo Cool** - When Turbo Cool is activated, the unit will cool at 61°F on fan high for 10 minutes and then return to the original settings.
- 7) **Bucket Full** - When the unit cannot evaporate the collected moisture fast enough, the excess water will collect in a backup water tank located inside the unit. The BUCKET FULL indicator will light up.
- 8) **Louver Direction** - This unit has 2-way directional louvers. Use the louver guides manually to direct air up and down.



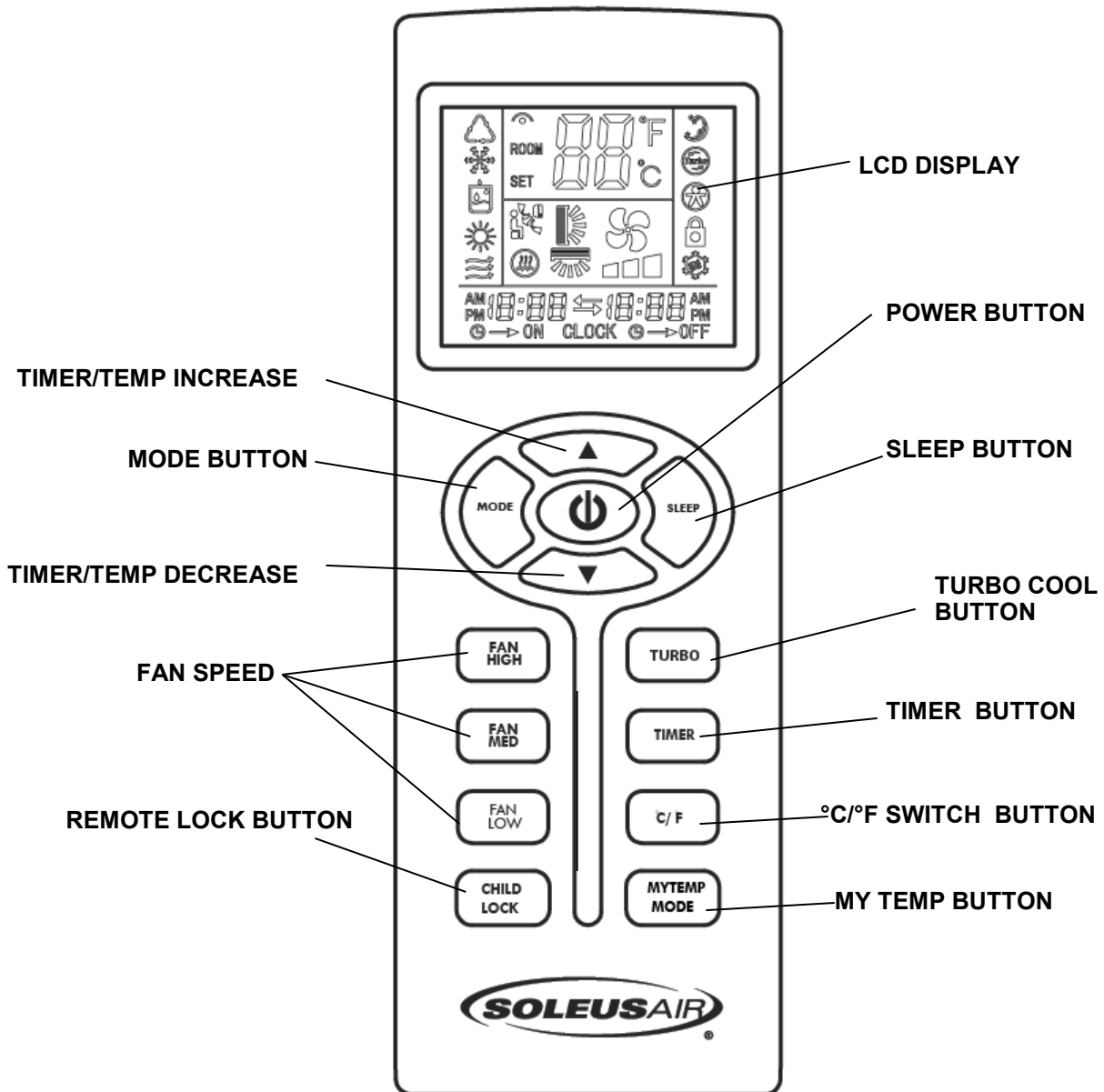

REMOTE CONTROL

- 1) **Power On and Off** - When the unit is plugged in, press the **POWER**  button to turn on the unit. Press the **POWER** button once more to turn the unit off. When in Air Conditioner mode, Auto mode, and Sleep mode, the selected temperature will appear on the remote control LCD display. When the unit is in Fan mode or Dehumidifier mode, no temperature will be displayed. This shows that temperature selection is not available when the unit is in Fan mode and Dehumidifier mode.
 - 2) **Mode Selection** - Press the **MODE** Button repeatedly to cycle between the different modes: Auto, Sleep, Air Conditioner, Dehumidifier, and Fan-Only mode. The mode icon on LCD display will light up showing which mode is selected.
 - 3) **Fan Speed** - Press the **FAN HIGH, FAN MED, or FAN LOW** button to choose desired fan speed. When the unit is in Dehumidifier mode, the fan speed cannot be changed. When Turbo Cool is activated, fan speed is automatically set on high and is not adjustable in this mode.
 - 4) **Temperature Setting** - When the unit is in Air Conditioner mode, you can select your desired temperature. Press the **▲** or **▼** to select your desired temperature setting. The temperature on the LCD display on the remote control will increase or decrease accordingly. Pressing the **°C /°F** button will switch the temperature select between °C and °F.
 - 5) **SLEEP MODE** - When in air conditioning mode, press the **SLEEP** Button on the remote control, Sleep mode icon will show on the remote control LCD display. When in **SLEEP** mode, the fan will run on low to keep fan noise at a minimum. The temperature setting will gradually increase to 2°F above the original set temperature each of first 2 hours. The unit will keep operating the same temperature until the sleep mode is turned off.
 - 6) **TIMER** -
Auto-On: Press the **TIMER** button when the unit is off to set up the Auto-on timer. The hour indicator on the LCD display will turn on. Press the **TIMER** buttons to set timer within 1-24 hours.
Auto-Off: Press the **TIMER** button when the unit is On to set up the Auto-off timer. The hour indicator on the LCD display will turn on, Press the **TIMER** buttons to set timer within 1-24 hours. To cancel the timer, press **TIMER** button until the timer mode is turned off.
 - 7) **TURBO COOL** - Press the **Turbo Cool** button to activate Turbo Cool mode. The unit will cool at 61°F on fan high for 10 minutes and then return to the original settings. Fan speed is not adjustable in this mode.
- NOTE:** If Fan mode activates less than 3 minutes and switches to Turbo Cool, it will be a compressor protection shut down, compressor will turn on again until the 3 minutes is topped off.
- 8) **MY TEMP MODE** - Press this button to change the thermostat sensor from the air conditioner to the remote control location. The air conditioner will cool the area at the location and set temperature of the remote control.
 - 9) **CHILD LOCK** - Press this button to lock/unlock the remote control buttons.



Air Conditioner Mode

- 1) Install the exhaust hose and window kit properly (see pages 8&9).
- 2) Plug the power cord into an electrical outlet.
- 3) Turn on the unit by pressing the **POWER** button.
- 4) Press the **MODE** button until the air conditioner mode indicator lights up on the control panel display.
- 5) Press the + or - until the desired room temperature appears on the control panel display. The temperature ranges from 61°F - 88°F.
- 6) Select the desired fan speed by pressing the **FAN SPEED** button.

NOTE: During hot days, the unit will cool the room most efficiently by setting the temperature at the lowest setting and the fan speed on high. Reducing the length of the exhaust duct, insulating the exhaust hose and window kit, and keeping direct sunlight to a minimum will also improve the cooling efficiency.

NOTE: When the unit is running on air conditioning mode, the exhaust hose is required and must be vented outside using the supplied window kit.

Dehumidifier Mode

- 1) Install the exhaust hose and window kit properly (see pages 8&9).
- 2) Plug the power cord into an electrical outlet.
- 3) Turn on the unit by pressing the **POWER** button.
- 4) Press the **MODE** button until the Dehumidifier Mode indicator lights up on the control panel display.
- 5) Temperature indicator displays room temperature.

NOTE: The unit operates at low fan speed while in Dehumidifier Mode. The unit cools room slightly during the dehumidification process. Keep windows and doors closed to aid the effectiveness of the unit in removing the moisture from the room.

NOTE: When the unit is running on Dehumidifier Mode, the exhaust hose is required and must be vented outside using the supplied window kit.

NOTE: The unit will not perform in Dehumidifier Mode when the room temperature is lower than 50°F .



Auto Mode

- 1) Install the exhaust hose and window kit properly (see pages 8&9).
- 2) Plug the Power cord into an electrical outlet.
- 3) Turn on the unit by pressing the **POWER** button.
- 4) Press the **MODE** button until the Auto mode indicator lights up on the control panel display.

Auto Mode will operate the unit in Air Conditioning Mode when the temperature is above 72 degrees, Fan Mode when the temperature is below 72 degrees.

Sleep Mode

- 1) Install the exhaust hose and window kit properly (see pages 8&9).
- 2) Plug the power cord into an electrical outlet.
- 3) Turn on the unit by pressing the **POWER** button on the control panel.
- 4) Press the **MODE** button until the Sleep Mode indicator lights up on the control panel display.

NOTE: When in Sleep Mode, the fan will run on low to keep fan noise at a minimum. The temperature setting will gradually increase to 2°F above the original set temperature each of first 2 hours. The unit will keep operating the same temperature until the Sleep Mode is turned off.

Fan Mode

- 1) Plug the power cord into an electrical outlet.
- 2) Turn on the unit by pressing the **POWER** button on the control panel.
- 3) Press the **MODE** button until the fan mode indicator lights up on the control panel display.
- 4) Select the fan speed by pressing the **FAN SPEED** button.

NOTE: It is not necessary for the exhaust hose and window kit to be installed to operate the unit in fan mode.



BUCKET FULL INDICATOR

When the Internal Water Tank is full, the Bucket Full light will illuminate and the unit will automatically shut down. The air conditioner will resume normal operation once Internal Water Tank is emptied.

INTERNAL WATER TANK

When the room temperature is low and the indoor humidity is high, the air conditioner may not be able to evaporate some of the moisture fast enough. When this happens, the water will accumulate in an internal water tank inside the unit. The internal water tank holds approximately 1.5 liters of water. When this tanks becomes full, the unit will automatically shutdown and illuminate the Bucket Full indicator.

HOW TO INSTALL CONTINUOUS DRAIN OPTION:

1. Place the Portable AC on a level surface.
2. Remove the cap on continuous drain port on the back of the unit to access the Continuous Drain Port.
3. Thread a *Garden Hose (not supplied)* onto the accessible Continuous Drain Port.
4. Lead *Garden Hose* to a floor drain and cut to length.
5. Make sure that there are no kinks or knots in the *Garden Hose* (Fig 16.1).
6. Turn on the unit and gravity draining will begin automatically.

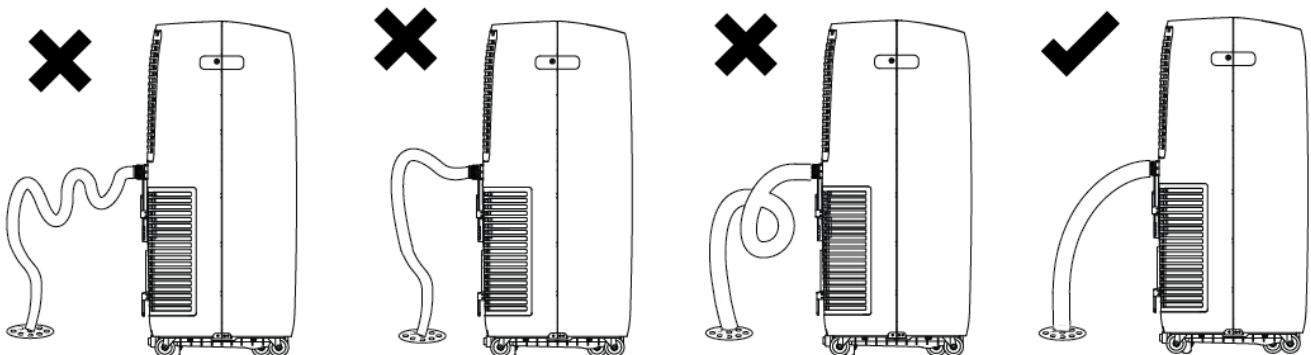

Fig 16.1

HOW TO DRAIN THE INTERNAL WATER TANK

*You will need a small pan, approximately 1” high to catch the water coming out of the water tank. Once the water tank is empty, the unit will resume operation within a few minutes.

1. Do not move the unit when the water container is full (water will spill out).
2. Place a small pan under the condensation drain hole on the bottom side of the unit.
3. Remove the drain plug from the condensation drain hole. The condensate water will drain out automatically.
4. When the drain pan is full, install the drain plug back onto the condensation drain hole to stop the water flow.
5. Empty the drain pan.
6. Repeat steps 2-5 until all the water is emptied.

NOTE: Once the condensate tank has been emptied, firmly press the drain plug back onto the condensation drain hole (Fig 17.1). It is not advised to use continuous drainage when the room temperature is higher than 90°F.

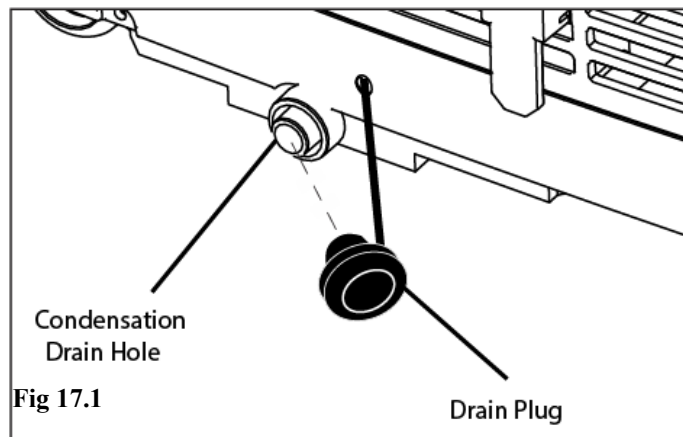

NOTE: You may also use enclosed Optional Drain Tube to facilitate the draining process, make sure to re-plug the Drain Stopper once the condensation tank has been emptied (Fig 17.2).

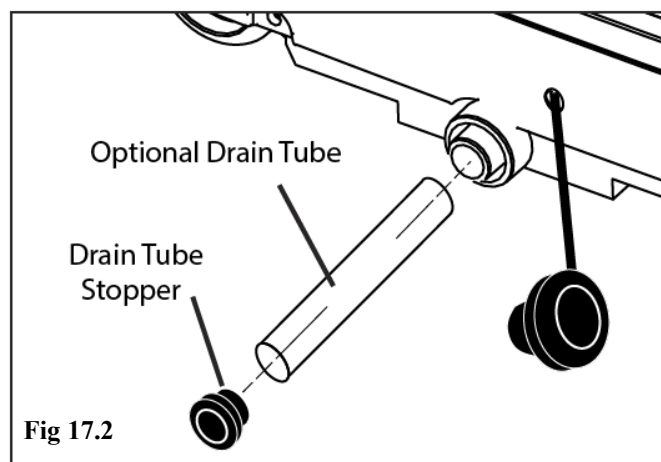

NOTE: Make sure power is off and the power cord is not plugged into an electrical outlet prior to performing any maintenance on the unit.

Clean or Replace Filter - If the air filter is blocked with a dust, the airflow volume may reduce. It is recommended to clean the filter once every two weeks or as needed.

- 1) Remove the filter from the filter compartment on the back of the unit.
- 2) Wash the air filter by immersing it gently into warm water with a neutral detergent. Rinse the filter and dry it thoroughly out of sunlight.
- 3) Slide the filter back into the filter compartment after it is thoroughly dried.
- 4) If the filter is torn or unusable, order a new filter by calling the customer service number on the warranty page of this manual.

Clean the Unit Housing

- 1) Keep the unit from being exposed directly to the sun to prevent color fading.
- 2) Clean the surface with a damp cloth and dry it with a soft towel.

Storing the Unit for an Extended Period of Time or Transporting the Unit

- 1) Empty excess water by unplugging the drain plug in the back of the unit (located at the bottom).
- 2) Unplug the unit.
- 3) The unit should be stored in a cool dry place.

DISCLAIMER

ALL INFORMATION AND THE TECHNICAL SPECIFICATIONS PRESENTED IN THIS USER'S MANUAL ARE THE PRESENTATION OF THE MANUFACTURER. SOLEUS N.A HAS NOT CONDUCTED AN INDEPENDENT TEST TO THE INFORMATION AND THE SPECIFICATIONS PRESENTED HEREWITHIN.



PROBLEM	CAUSE	SOLUTION
Air conditioner does not power on	<ul style="list-style-type: none"> • Unit is not plugged in • No electric current to outlet • Internal safety device has tripped 	<ul style="list-style-type: none"> • Plug unit in • Check electric breaker box for a trip • Wait 30 minutes for safety device to reset
Air conditioner works for a limited amount of time	<ul style="list-style-type: none"> • There are bends in the exhaust hose • Something is blocking the air from being discharged 	<ul style="list-style-type: none"> • Position the air exhaust hose correctly, keeping it as short and free of curves as possible • Check and remove anything obstructing air discharge
During operation, there is an unpleasant smell in the room	<ul style="list-style-type: none"> • Air filter is dirty 	<ul style="list-style-type: none"> • Remove air filters, clean and re-install
Air conditioner does not operate after restarting the unit	<ul style="list-style-type: none"> • The internal compressor safety device prevents the unit from being restarted until three minutes have elapsed since it was last turned off 	<ul style="list-style-type: none"> • Wait for compressor to turn on (approximately 3 minutes)
The control panel display shows Error Codes	<ul style="list-style-type: none"> • The unit has a self diagnosis system to identify a number of malfunctions 	<ul style="list-style-type: none"> • See page 20 Self-Diagnosis
Bucket Full indicator is illuminated and unit will not blow air	<ul style="list-style-type: none"> • Internal water tank is full and needs to be drained 	<ul style="list-style-type: none"> • Drain internal water tank (see page 17)

SELF-DIAGNOSIS

The unit has a self diagnosis system to identify a number of malfunctions. Error codes are displayed on the appliance display.

Error Code	Possible Causes	Solution
E1	Outdoor Pipe Temperature Sensor Failure	Turn the unit on and off to remove error code. If this code appears again, please call customer service at (877)-665-9765
E2	Indoor Temperature Sensor Failure	Turn the unit on and off to remove error code. If this code appears again, please call customer service at (877)-665-9765
E3/E4	Coil Pipe Sensor Failure	Please call customer service at (877)-665-9765
E7	Heating Mode Low-Temperature Protection	Please makes sure the room temperature is above 41F when using Heating Mode. If this code appears again, please call customer service at (877)-665-9765
E8	Overheat protection	Please turn off the unit and check surrounding temperature. If the error code continue appearing, please call customer services at (877)-665-9765.



Two Year Components Limited Warranty Five Year Compressor Limited Warranty

Soleus N.A. warrants the accompanying Soleus Air Portable Air Conditioner to be free of defects in material and workmanship for the applications specified in its operation instruction for a period of TWO (2) year for components and FIVE (5) years for the compressor from the date of original retail purchase in the United States.

If the unit exhibits a defect in normal use, Soleus N.A. will, at its option, either repair or replace it, free of charge within a reasonable time after the unit is returned during the warranty period.

As a condition to any warranty service obligation, the consumer must present this Warranty Certificate along with a copy of the original purchase invoice.

THIS WARRANTY DOES NOT COVER:

- Damage, accidental or otherwise, to the unit while in the possession of a consumer not caused by a defect in material or workmanship.
- Damage caused by consumer misuse, tampering, or failure to follow the care and special handling provisions in the instructions.
- Damage to the finish of the case, or other appearance parts caused by wear.
- Damage caused by repairs or alterations of the unit by anyone other than those authorized by Soleus N.A.
- Freight and Insurance cost for the warranty service.
- Filter and Accessories.

ALL WARRANTIES, INCLUDING ANY IMPLIED WARRANTY OF MERCHANT ABILITY ARE LIMITED TO THE DURATION OF THIS EXPRESS LIMITED WARRANTY. **SOLEUS N.A. DISCLAIMS ANY LIABILITY FOR CONSEQUENTIAL OR INCIDENTAL DAMAGES AND IN NO EVENT SHALL SOLEUS N.A.'S LIABILITY EXCEED THE RETAIL VALUE OF THE UNIT FOR BREACH OF ANY WRITTEN OR IMPLIED WARRANTY WITH RESPECT TO THIS UNIT.**

This warranty covers only new products purchased from our authorized dealers or retailers. It does not cover used, salvaged, or refurbished products.

As some states do not allow the limitation or exclusion of incidental or consequential damages, or do not allow limitation on implied warranties, the above limitations and exclusions may not apply to you. This warranty gives you specific legal rights, and you may also have other rights that vary from state to state.

For Technical Support and Warranty Service

Please Call (877) 665-9765

www.soleusna.com

