

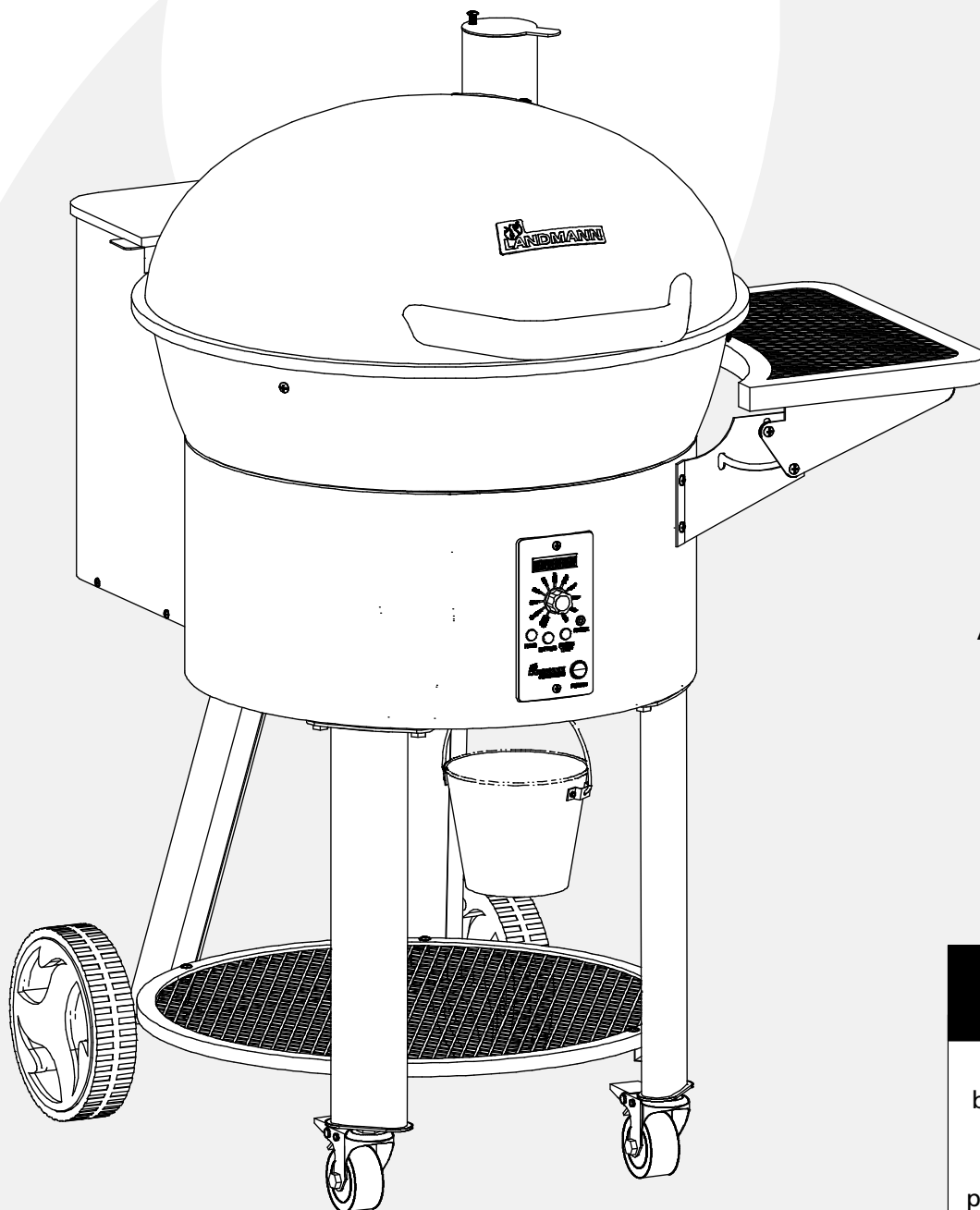

LANDMANN® Pellet Kettle



Pellet Kettle Grill

Assembly and Operating Instructions for Model: 470106

VER. 7, 7/28/2017

A MAJOR CAUSE OF FIRES IS FAILURE TO MAINTAIN REQUIRED CLEARANCES (AIR SPACES) TO COMBUSTIBLE MATERIALS. IT IS OF UTMOST IMPORTANCE THAT THIS PRODUCT BE INSTALLED ONLY IN ACCORDANCE WITH THESE INSTRUCTIONS.



Appliance Type: Pellet Fuel
Burning Cooking Appliance
Test Standards

Conforms To:
UL Subject 2728
Certified To:
ULC/ORD STD C2728



Please read this entire manual before assembling and using this pellet fuel burning appliance. Failure to follow these instructions could result in property damage, bodily injury or even death.

Contact local building or fire officials about restrictions and installation inspection requirements in your area.

Please save this instruction manual for future reference.

READ FIRST! RULES FOR PELLET KETTLE GRILL SAFE OPERATION.

- **WARNING!** THE GRILL IS FOR OUTDOOR USE ONLY!
- **WARNING!** NEVER USE GASOLINE, GASOLINE-TYPE FUEL, KEROSENE, CHARCOAL LIGHTER FLUID, OR SIMILAR LIQUIDS TO START OR "FRESHEN UP" A FIRE IN THIS APPLIANCE. KEEP ALL SUCH LIQUIDS AWAY FROM THE APPLIANCE WHEN IN USE.
- DO NOT STORE FLAMMABLE LIQUIDS OR MATERIALS ON THE BOTTOM SHELF OR SIDE SHELF.
- THE GRILL IS FOR ADULT USE ONLY.

- **WARNING!** THIS GRILL GETS EXTREMELY HOT DURING USE! USE EXTREME CAUTION AROUND THE GRILL.
- USE CAUTION WHEN OPENING THE LID AS HOT STEAM OR A FLARE UP COULD CAUSE BURNS.
- KEEP THE GRILL A MINIMUM OF 24 IN. AWAY FROM BUILDINGS, STRUCTURES, ANY FLAMMABLE ITEMS AND VEHICLES DURING USE.
- KEEP CHILDREN AND PETS AWAY WHILE THE GRILL IS BEING USED.
- USE CAUTION AFTER THE FIRE HAS BEEN EXTINGUISHED- SURFACES WILL REMAIN HOT FOR SOME TIME.

- **WARNING!** NEVER PUT YOUR FINGERS IN THE AUGER CHANNEL FOR ANY REASON!
- THE HOPPER PELLET FUEL SCREEN MUST BE IN PLACE DURING USE.

- NEVER USE THE GRILL UNDER COVERED PORCHES, AWNINGS, COMBUSTIBLE CEILINGS, LOW HANGING TREE BRANCHES, TRELIS, OR OVERHANGS OF ANY KIND.
- NEVER USE INSIDE ENCLOSED AREAS SUCH PATIOS, GARAGES, ENCLOSED ROOMS, BUILDINGS OR TENTS.
- DO NOT USE IN WINDY CONDITIONS.
- DO NOT USE IN VERY WET OR RAINY CONDITIONS.

- KEEP THE LID CLOSED DURING USE. THIS PELLET GRILL IS INTENDED TO BE USED WITH A CLOSED LID.
- NEVER USE THIS GRILL AS A HEATER.
- THIS GRILL IS NOT FOR COMMERCIAL USE.
- BEFORE STARTING, MAKE SURE THE GREASE BUCKET IS IN PLACE.
- ALWAYS UNPLUG GRILL AFTER USING. WIND CORD AROUND THE CORD WRAP SO IT IS OUT OF THE WAY.
- DURING USE, THE PLUG WIRING SHOULD BE SORTED SO IT DOES NOT IMPOSE A TRIPPING HAZARD.
- ALWAYS USE THE GRILL ON A HARD, STABLE AND LEVEL SURFACE.

- THIS GRILL OPERATES AUTOMATICALLY THROUGH THE CONTROL PANEL. DO NOT MANUALLY FILL THE FIRE POT OR OVER-FILL THE FIRE POT BY HAND. THIS WILL CAUSE A DANGEROUS OVER-FIRING CONDITION.

- THE SIDE SHELF CAN HOLD 15 LBS. SAFELY, DO NOT PUT MORE THAN 15 LBS. ON THE SIDE SHELF.
- DO NOT LEAN OR PUSH DOWN ON THE SIDE SHELF.
- DO NOT MOVE THE GRILL WHILE IT IS BEING USED.
- DO NOT USE ACCESSORIES NOT SPECIFIED FOR USE WITH THIS APPLIANCE.
- MAKE SURE THE FRONT WHEEL CASTERS ARE LOCKED WHILE IN USE.
- DO NOT LEAVE UNATTENDED AT ANY TIME WHILE IN USE.

- BEFORE EACH USE, MAKE SURE THE GRILL IS IN GOOD WORKING CONDITION.
- DO NOT ALTER THE GRILL IN ANY WAY.
- DO NOT MODIFY OR HARDWIRE THE AUGER TO RUN CONTINUOUSLY.
- DO NOT USE THE GRILL UNTIL IT IS COMPLETELY ASSEMBLED WITH ALL PARTS SECURELY TIGHTENED.
- THE GRILL MUST BE COMPLETELY COOLED OFF AND MUST BE EXTINGUISHED BEFORE ANY COVER CAN BE USED.

- MAINTAINING THE GRILL IS THE RESPONSIBILITY OF THE OWNER OR USER. THE FIREBOWL, DRIP TRAY AND DRIP TRAY TUBE MUST BE CLEANED OCCASIONALLY TO REMOVE GREASE BUILDUP. FAILURE TO CLEAN GREASE BUILDUP CAN CAUSE GREASE FIRES WHICH ARE VERY DANGEROUS.
- **WARNING!** AFTER EVERY 20 HRS OF USE, THE FIRE POT MUST BE CLEANED OUT TO REMOVE ANY ASH BUILDUP. THIS IS REQUIRED MAINTENANCE.
- NEVER POUR WATER INTO THE FIREBOWL, FIRE POT OR DRIP TRAY.
- IF A GREASE FIRE WERE TO OCCUR, BAKING SODA CAN BE USED TO EXTINGUISH THE FIRE. USE EXTREME CAUTION NOT TO BURN YOURSELF.
- IF THE FIRE DOES NOT EXTINGUISH, REMOVE THE FOOD IF POSSIBLE. KEEP THE LID CLOSED, CLOSE THE CHIMNEY DAMPER AND PRESS THE POWER BUTTON TO OFF.
- ONCE THE FIRE IS EXTINGUISHED, CLEAN THE GREASE BUILDUP BEFORE COOKING IS RESUMED.

- DISPOSAL OF ASHES - ANY ASHES THAT ARE REMOVED FROM THE GRILL SHOULD BE PLACED IN A METAL CONTAINER WITH A TIGHT FITTING LID. THE CLOSED CONTAINER OF ASHES SHOULD BE PLACED ON A NONCOMBUSTIBLE FLOOR OR GROUND, WELL AWAY FROM ALL COMBUSTIBLE MATERIALS, PENDING FINAL DISPOSAL. IF THE ASHES ARE DISPOSED OF BY BURIAL IN SOIL OR OTHERWISE LOCALLY DISPERSED, THEY SHOULD BE RETAINED IN THE CLOSED CONTAINER UNTIL ALL CINDERS HAVE THOROUGHLY COOLED.

READ FIRST! RULES FOR PELLET KETTLE GRILL SAFE OPERATION.

! WARNING!

CARBON MONOXIDE HAZARD!

BURNING WOOD OR CHARCOAL PRODUCES CARBON MONOXIDE, WHICH HAS NO ODOR AND CAN CAUSE DEATH IF BURNED IN ENCLOSED AREAS. NEVER BURN WOOD OR CHARCOAL INSIDE HOMES, VEHICLES, TENTS OR ANY OTHER ENCLOSED AREAS.

NOTE THE FOLLOWING TO PREVENT THIS COLORLESS, ODORLESS GAS FROM POISONING YOU, YOUR FAMILY OR OTHERS:

- KNOW THE SYMPTOMS OF CARBON MONOXIDE POISONING: HEADACHE, DIZZINESS, WEAKNESS, NAUSEA, VOMITING, SLEEPINESS, AND CONFUSION. CARBON MONOXIDE REDUCES THE BLOOD'S ABILITY TO CARRY OXYGEN. LOW BLOOD OXYGEN LEVELS CAN RESULT IN LOSS OF CONSCIOUSNESS AND DEATH.
- SEE A DOCTOR IF YOU OR OTHERS DEVELOP COLD OR FLU-LIKE SYMPTOMS WHILE COOKING OR IN THE VICINITY OF THIS APPLIANCE. CARBON MONOXIDE POISONING, WHICH CAN EASILY BE MISTAKEN FOR A COLD OR FLU, IS OFTEN DETECTED TOO LATE.
- CARBON MONOXIDE IS ESPECIALLY TOXIC TO MOTHER AND CHILD DURING PREGNANCY, INFANTS, THE ELDERLY, SMOKERS, AND PEOPLE WITH BLOOD OR CIRCULATORY SYSTEM PROBLEMS, SUCH AS ANEMIA OR HEART DISEASE.

! FUEL

- USE ONLY FOOD GRADE HARDWOOD PELLETS MADE FOR PELLET GRILLS.
- DO NOT USE HEATING PELLETS WHICH MAY CONTAIN HAZARDOUS CONTAMINANTS.
- IT IS RECOMMENDED THAT EXCESS PELLETS ARE NOT STORED IN THE HOPPER FOR EXTENDED PERIODS AS THEY CAN ABSORB MOISTURE CAUSING THE AUGER TO SEIZE.
- IF THE PELLETS ARE GOING TO BE STORED IN THE BAG THEY WERE PURCHASED IN, CLOSE THE BAG TIGHTLY AND PLACE IN A DRY LOCATION. A BETTER CHOICE IS A MOISTURE PROOF SEALED CONTAINER. CARE MUST BE TAKEN TO INSURE THE PELLET FUEL IS KEPT FROM ALL MOISTURE.
- DO NOT USE PELLETS THAT HAVE GOTTEN WET. DO NOT USE PELLETS THAT HAVE BECOME EXCESSIVELY POWDERY OR DUSTY. THIS IS A SIGN THE PELLETS ARE DEFECTIVE OR HAVE BEEN EXPOSED TO MOISTURE AT SOME TIME.

! DO NOT USE THIS APPLIANCE UNDER OVERHEAD COMBUSTIBLE SURFACES.

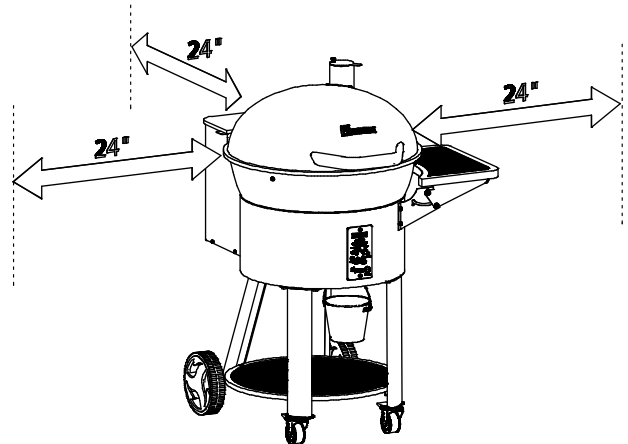

- KEEP THE GRILL A MINIMUM OF 24 IN. AWAY FROM BUILDINGS, STRUCTURES, ANY FLAMMABLE ITEMS AND VEHICLES DURING USE.
- NEVER USE THE GRILL UNDER COVERED PORCHES, AWNINGS, COMBUSTIBLE CEILINGS, LOW HANGING TREE, BRANCHES, TRELIS, OR OVERHANGS OF ANY KIND.
- IT IS RECOMMENDED THAT THE APPLIANCE BE INSTALLED ON NONCOMBUSTIBLE FLOORS. THE APPLIANCE CAN BE INSTALLED ON COMBUSTIBLE FLOORS WITH A NONCOMBUSTIBLE SURFACE WHERE THE PROTECTIVE SURFACE HAS BEEN APPROVED FOR SUCH USE BY THE AUTHORITY HAVING JURISDICTION.

! WARNING!

WOOD DUST AND FUELS USED IN WOOD BURNING APPLIANCES, AND THE PRODUCTS OF COMBUSTION OF SUCH FUELS, CONTAIN CHEMICALS KNOWN TO THE STATE OF CALIFORNIA TO CAUSE CANCER AND BIRTH DEFECTS OR OTHER REPRODUCTIVE HARM.

!

IT IS GOOD PRACTICE TO ALWAYS HAVE A WELL MAINTAINED FIRE EXTINGUISHER AVAILABLE WHENEVER ANY TYPE OF GRILL IS BEING USED.

! WARNING!

OUTDOOR USE ONLY

HARDWARE AND SMALL PART LISTING

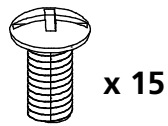

x 15

AA

(15) M6 x 12MM
BOLT

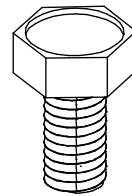

x 8

AB

(8) M8 x 15MM
HEXBOLT

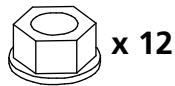

x 12

AC

(12) M6 FLANGE
HEXNUT

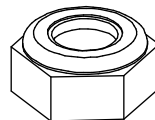

x 2

AE

(2) M10 LOCKING
HEXNUT

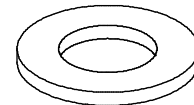

x 4

AF

(4) 20MM WASHER

ASSEMBLED PARTS

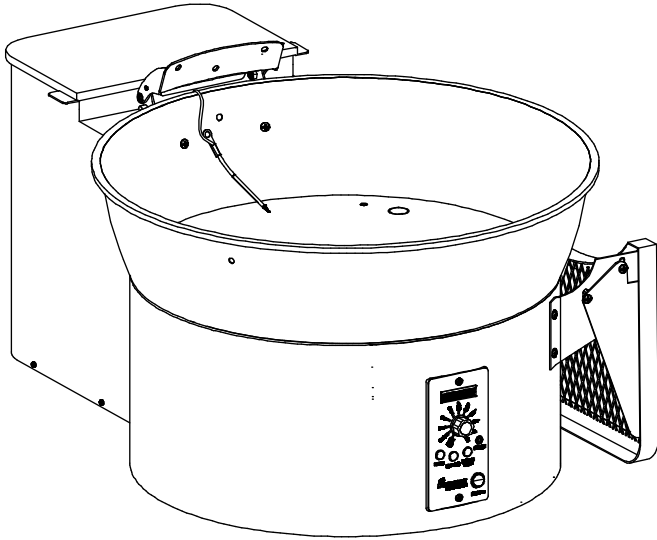

A
(1) MAIN GRILL ASSEMBLY

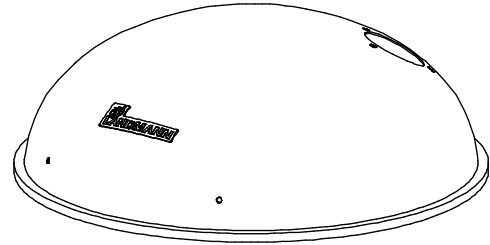

B
(1) LID

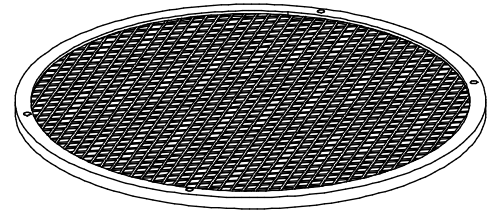

F
(1) BOTTOM SHELF

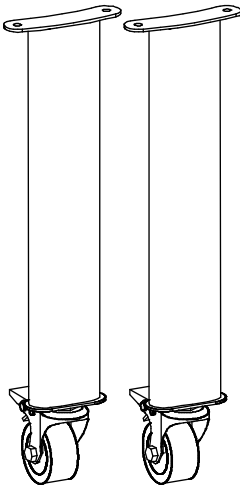

C
(2) FRONT LEGS

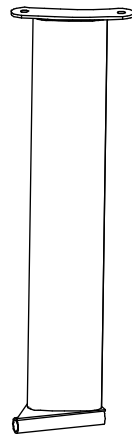

D
(1) RIGHT BACK LEG

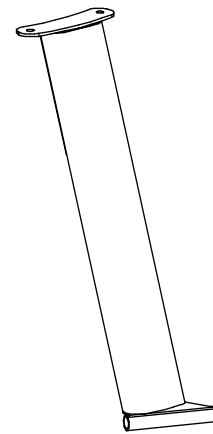

E
(1) LEFT BACK LEG

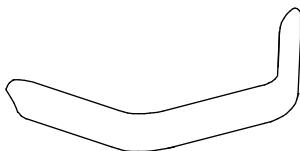

K
(1) LID HANDLE

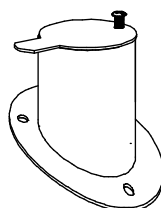

L
(1) CHIMNEY ASSEMBLY

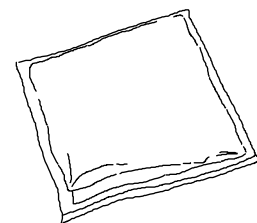

H
(1) COVER

ASSEMBLED PARTS

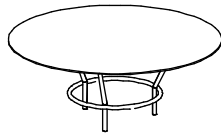

M

(1) HEAT DIFFUSER

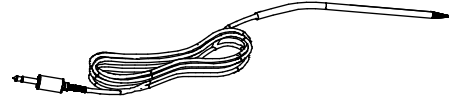

R

(1) MEAT PROBE

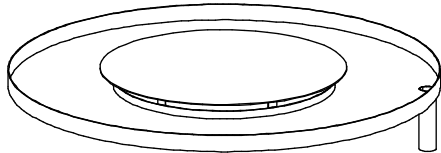

N

(1) DRIP TRAY

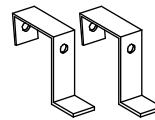

S

(2) LOW GREASE TRAY HOLDERS



T

(1) HIGH GREASE TRAY HOLDER

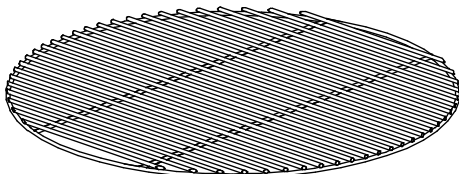

P

(1) COOKING GRATE

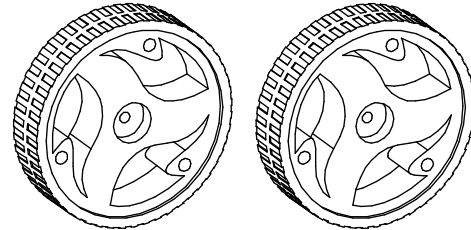

V

(2) WHEELS

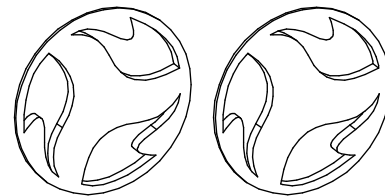

W

(2) WHEEL COVERS



Q

(1) GREASE BUCKET

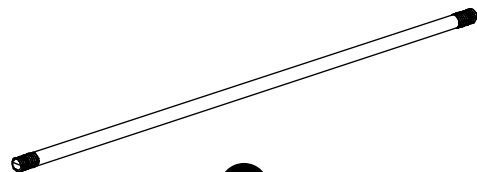

X

(1) WHEEL AXLE

EXPLODED VIEW FOR ASSEMBLED PARTS

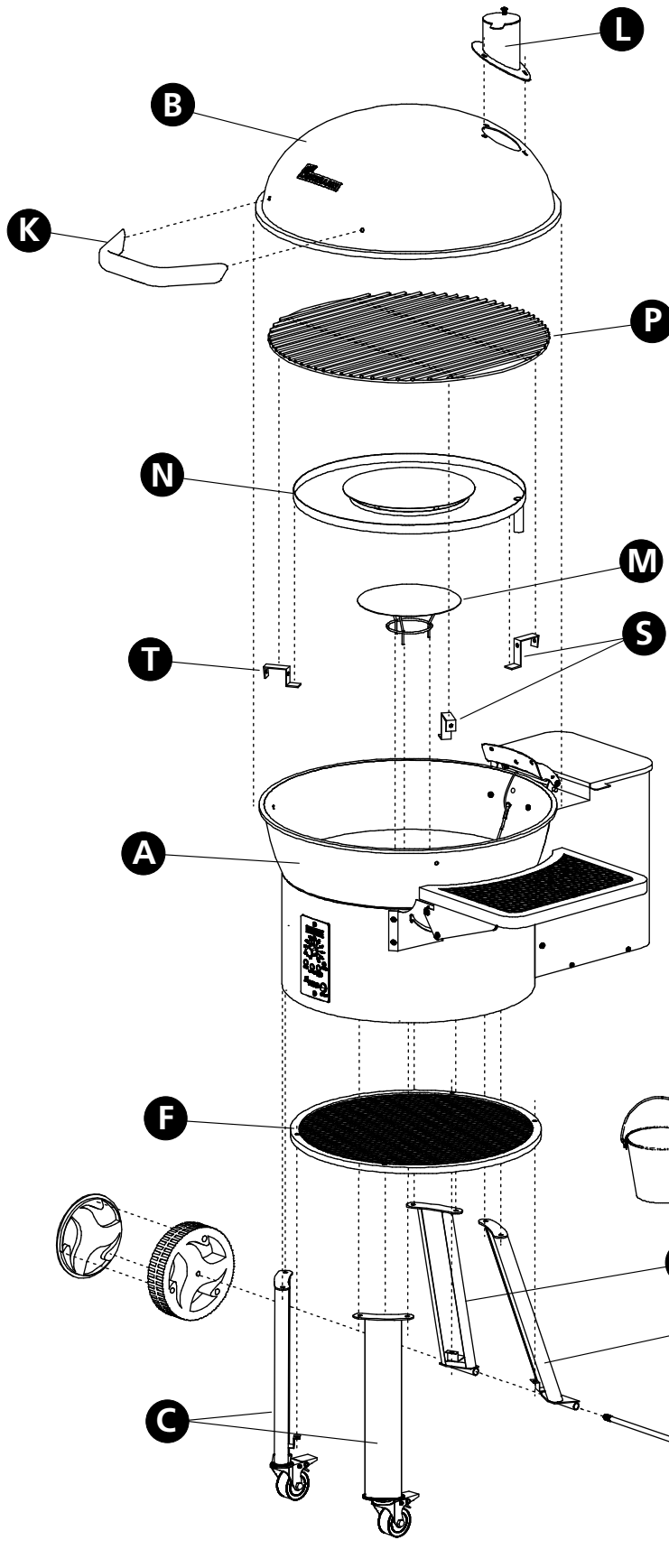

PELLET KETTLE PARTS	QTY
A. MAIN GRILL ASSEMBLY.....	1
B. LID	1
C. FRONT LEGS	2
D. RIGHT BACK LEG	1
E. LEFT BACK LEG	1
F. BOTTOM SHELF	1
H. COVER	1
K. LID HANDLE.....	1
L. CHIMNEY ASSEMBLY	1
M. HEAT DIFFUSER	1
N. DRIP TRAY	1
P. COOKING GRATE.....	1
Q. GREASE BUCKET	1
R. MEAT PROBE	1
S. LOW DRIP TRAY HOLDERS	2
T. HIGH DRIP TRAY HOLDER	1
V. WHEELS	2
W. WHEEL COVERS.....	2
X. WHEEL AXLE	1

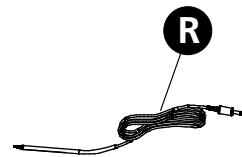

PELLET KETTLE ASSEMBLY INSTRUCTIONS

PAGE 8

LANDMANN.
Pellet Kettle



A Phillips or plain screwdriver and adjustable wrench are needed for assembly.

Assembly time: 45 minutes

STEP 1: ASSEMBLE THE LEGS

Very carefully turn the main grill assembly [A] over.

Assemble the (2) front legs [C] to the main grill using (4) hexbolts [AB]. Tighten securely.

Assemble the (2) back legs [D,E] to the main grill using (4) hexbolts [AB]. Tighten securely.

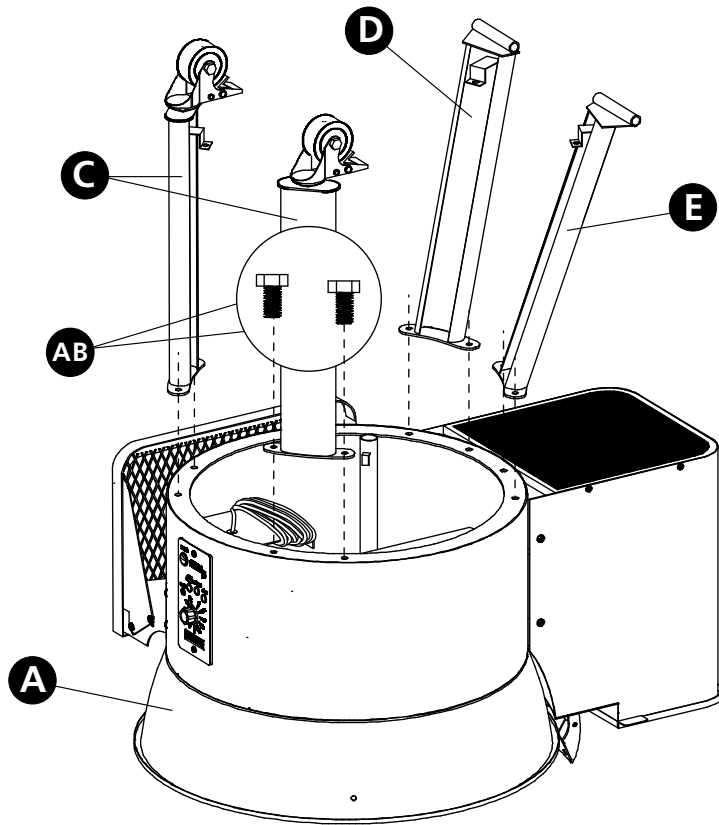

STEP 1

STEP 2: ASSEMBLE THE WHEEL AXLE AND THE WHEELS

Insert the wheel axle [X] through the back leg holders. To assemble the wheels [V], slide (1) washer [AF] onto each side of the axle. Slide the wheels on the axle, a washer [AF] and secure each wheel with a locking hexnut [AE].

Align the wheel cover [W] pins with the wheels and snap in place.

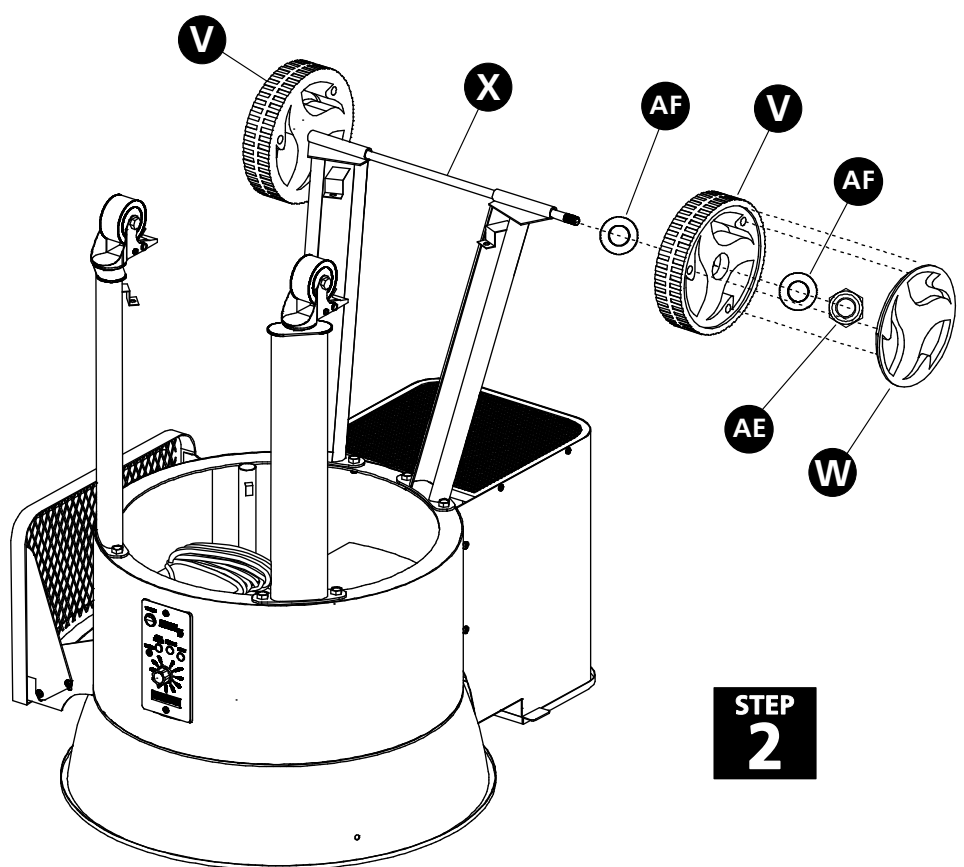

STEP 2

**DO NOT RETURN PRODUCT TO THE STORE.
IF YOU HAVE QUESTIONS OR HAVE
TROUBLE WITH ASSEMBLY, PLEASE CALL
1-877-347-4557 FOR ASSISTANCE.**

STEP 3: ASSEMBLE BOTTOM SHELF

Align the bottom shelf [F] with the tabs on the legs and assemble with (4) 12MM bolts [AA] and (4) M6 flange hexnuts [AC]. Tighten bolts securely.

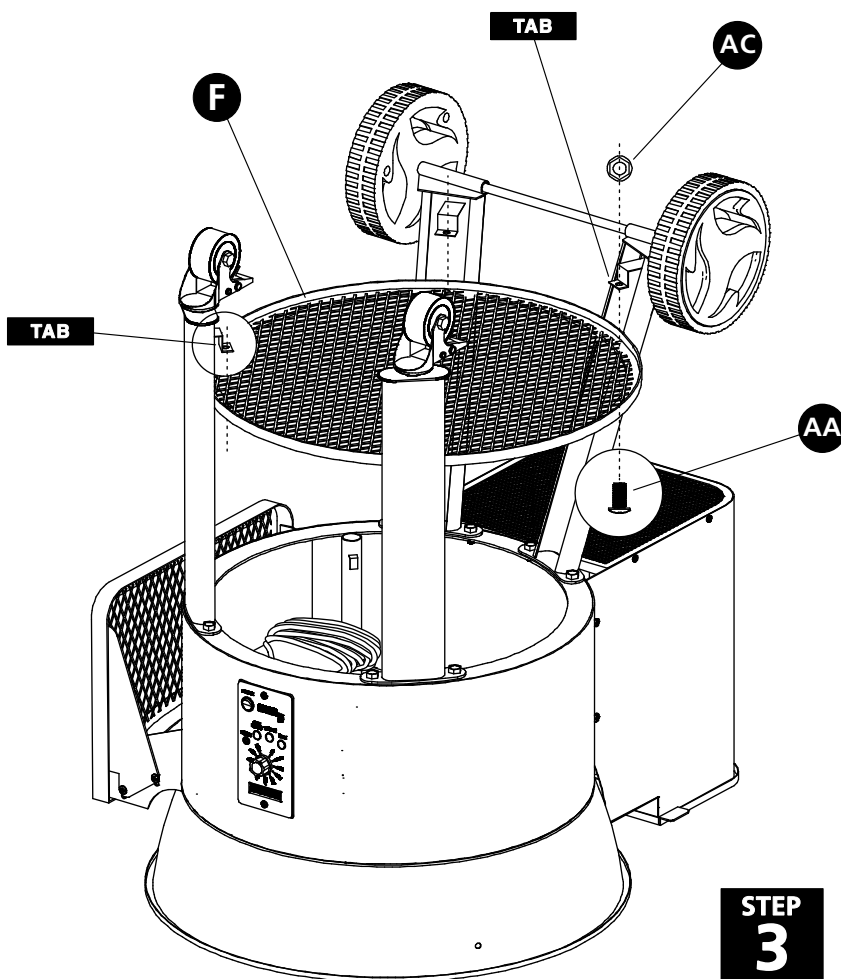

**DO NOT RETURN PRODUCT TO THE STORE.
IF YOU HAVE QUESTIONS OR HAVE
TROUBLE WITH ASSEMBLY, PLEASE CALL
1-877-347-4557 FOR ASSISTANCE.**

PELLET KETTLE ASSEMBLY INSTRUCTIONS

STEP 4: ASSEMBLE LID AND TEMPERATURE PROBE

Insert the temperature probe through the slot on the lid [B]. See STEP 4A.

Assemble the lid to the hinge using (2) 12MM bolts [AA] and (2) M6 flange hexnuts [AC].

Assemble the temperature probe using (1) 12MM bolt [AA] and (1) M6 flange hexnut [AC]. Align the probe so the tip is pointing upwards. See STEP 4B.

Add cooking oil to the pins and hinge. SEE STEP 4C.

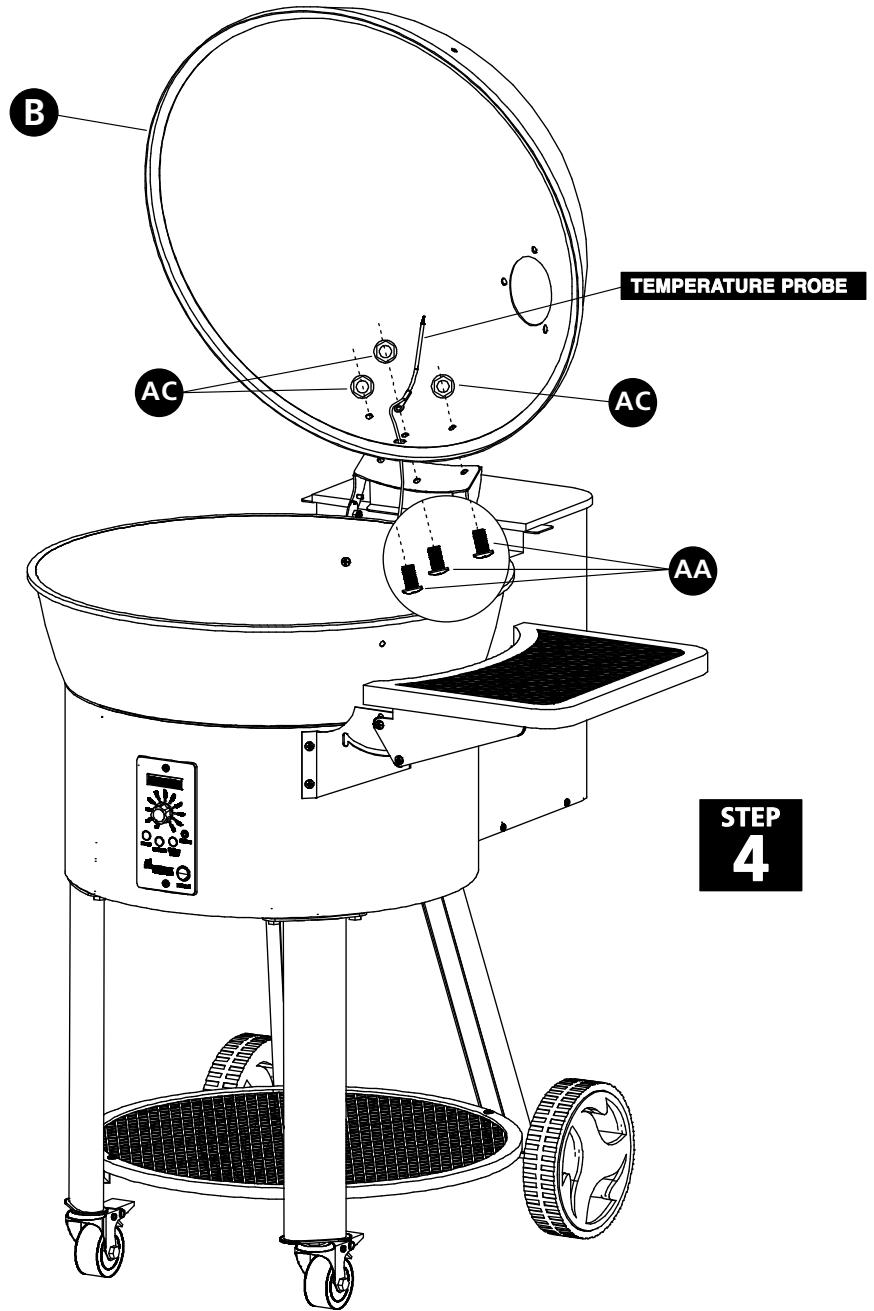
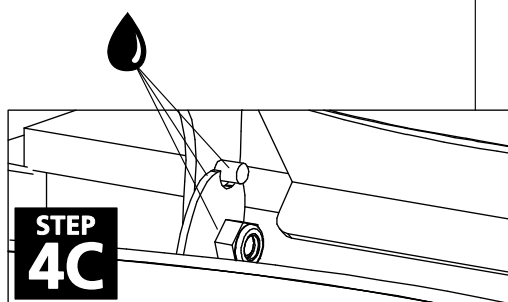
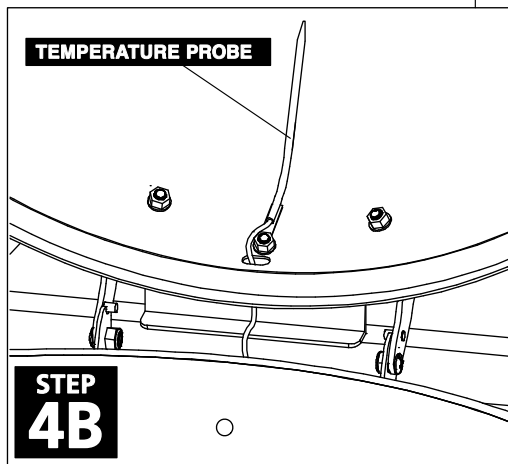
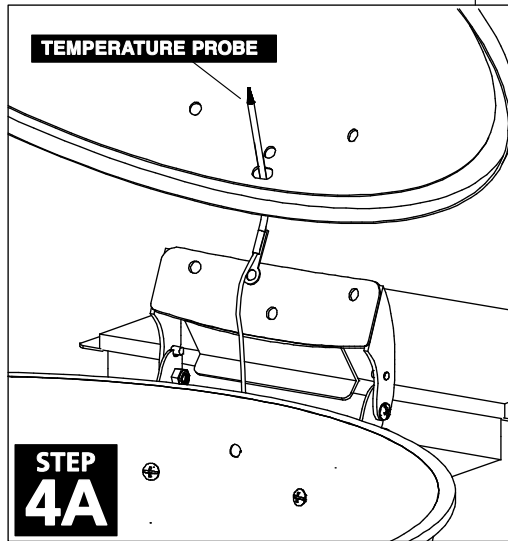

NOTE
ADD COOKING OIL TO THE
MOVING PINS AND PIVOTING
BOLTS ON THE HINGE.

STEP 5: ASSEMBLE THE LID HANDLE

Align the lid handle [K] with the holes in the lid and assemble using (2) 12MM bolts [AA]. Tighten securely.

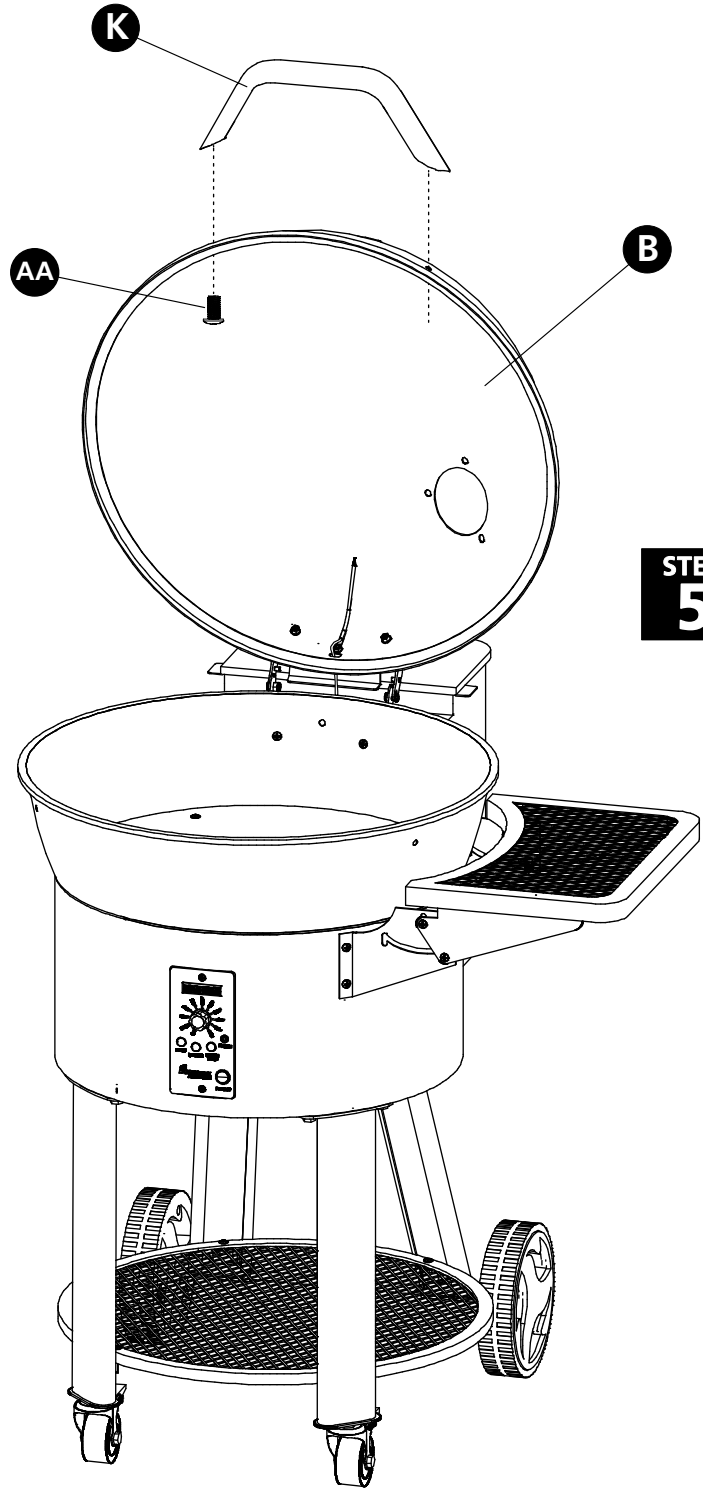

**STEP
5**

**DO NOT RETURN PRODUCT TO THE STORE.
IF YOU HAVE QUESTIONS OR HAVE
TROUBLE WITH ASSEMBLY, PLEASE CALL
1-877-347-4557 FOR ASSISTANCE.**

**STEP 6: ASSEMBLE THE CHIMNEY
ASSEMBLY**

Align the chimney assembly [L] with the lid. Assemble using (3) 12MM bolts [AA] and (3) M6 flange hexnuts [AC]. Tighten bolts securely.

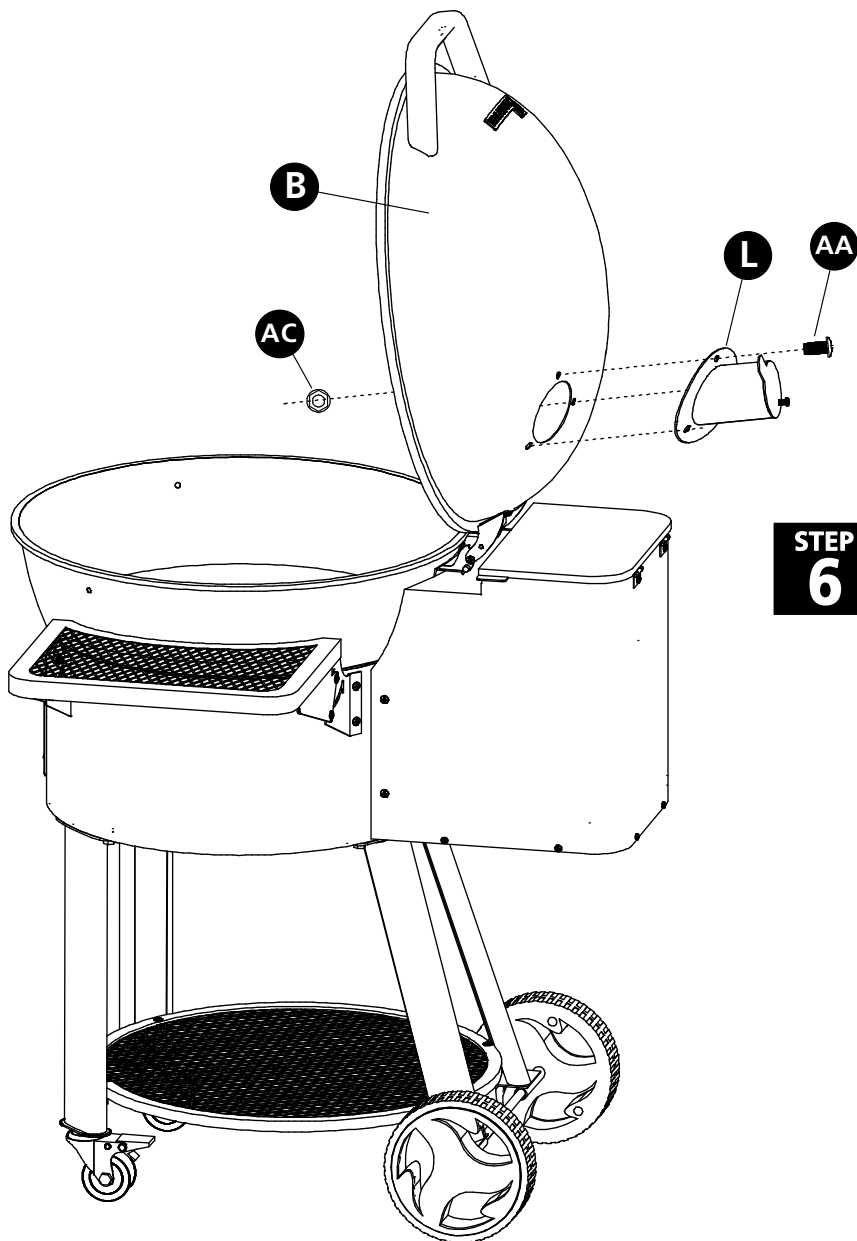

**STEP
6**

**DO NOT RETURN PRODUCT TO THE STORE.
IF YOU HAVE QUESTIONS OR HAVE
TROUBLE WITH ASSEMBLY, PLEASE CALL
1-877-347-4557 FOR ASSISTANCE.**

**STEP 7: ASSEMBLE THE DRIP PAN
HOLDERS**

Assemble (1) low drip pan holder [S] to the back of the firebowl using (1) 12MM bolt [AA]. This bolt will thread into the hinge.

Assemble (1) low drip pan holder [S] to the side shelf side of the firebowl using (1) 12MM bolt [AA] and (1) M6 flange hexnut [AC].

Assemble (1) high drip pan holder [T] to the firebowl using (1) 12MM bolt [AA] and (1) M6 flange hexnut [AC].

Make sure all holders are level and tighten the bolts securely.

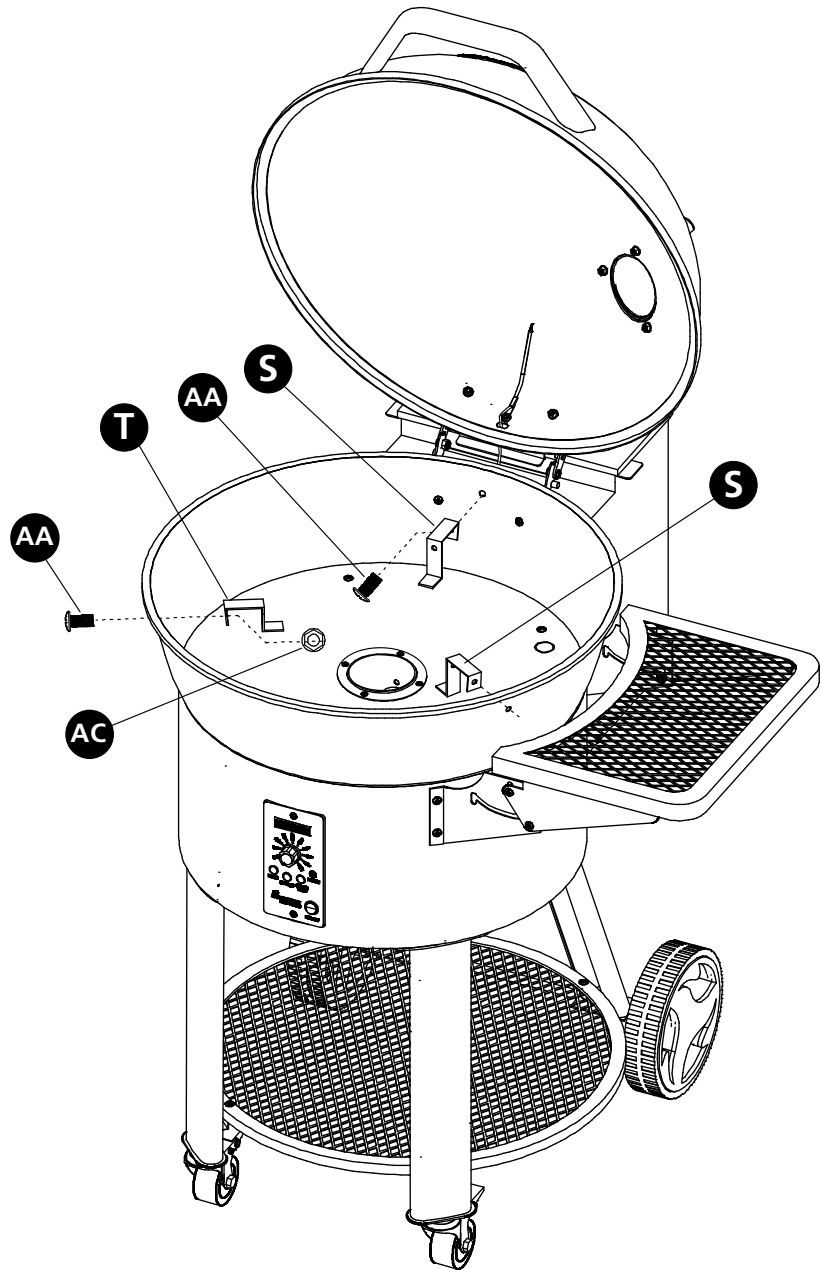

**STEP
7**

**DO NOT RETURN PRODUCT TO THE STORE.
IF YOU HAVE QUESTIONS OR HAVE
TROUBLE WITH ASSEMBLY, PLEASE CALL
1-877-347-4557 FOR ASSISTANCE.**

**STEP
8**

STEP 8: PLACE HEAT DIFFUSER

Place the heat diffuser [M] onto the fire pot. Make sure the diffuser is fully inserted and level.

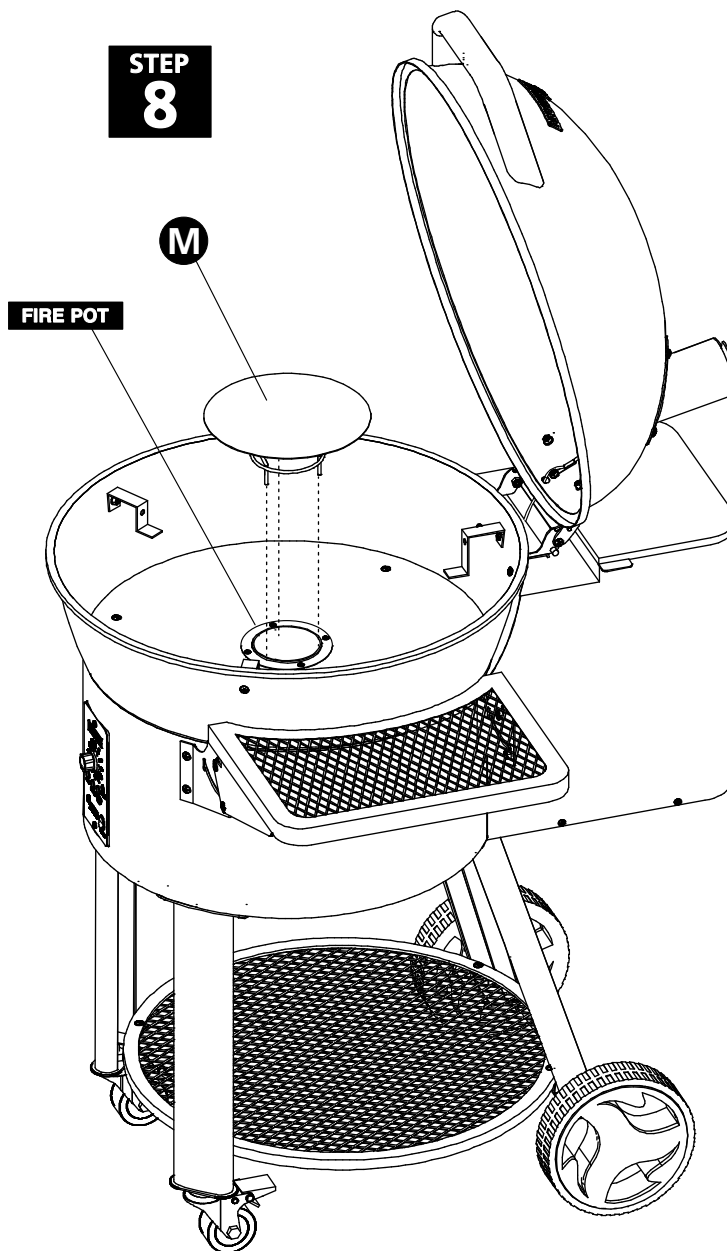

⚠ WARNING!
DO NOT OPERATE GRILL
WITHOUT THE HEAT
DIFFUSER IN PLACE.

**DO NOT RETURN PRODUCT TO THE STORE.
IF YOU HAVE QUESTIONS OR HAVE
TROUBLE WITH ASSEMBLY, PLEASE CALL
1-877-347-4557 FOR ASSISTANCE.**

**STEP
9**

STEP 9: PLACE DRIP TRAY

Align the drip tray [N] tube with the slot and place the drip tray on the holders.

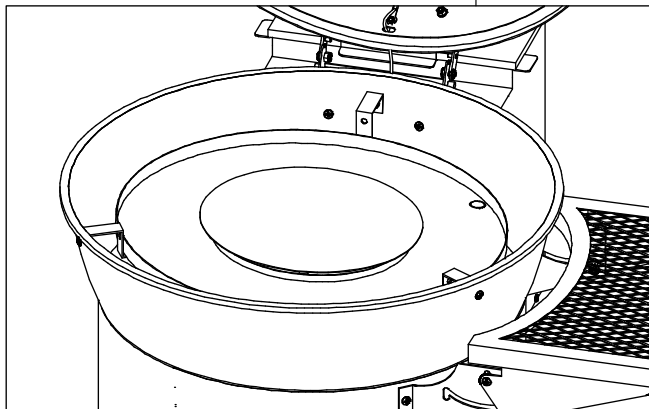

The drip tray will rest in an angled position. This allows the grease to move to the hole so it drop into the grease bucket to be collected.

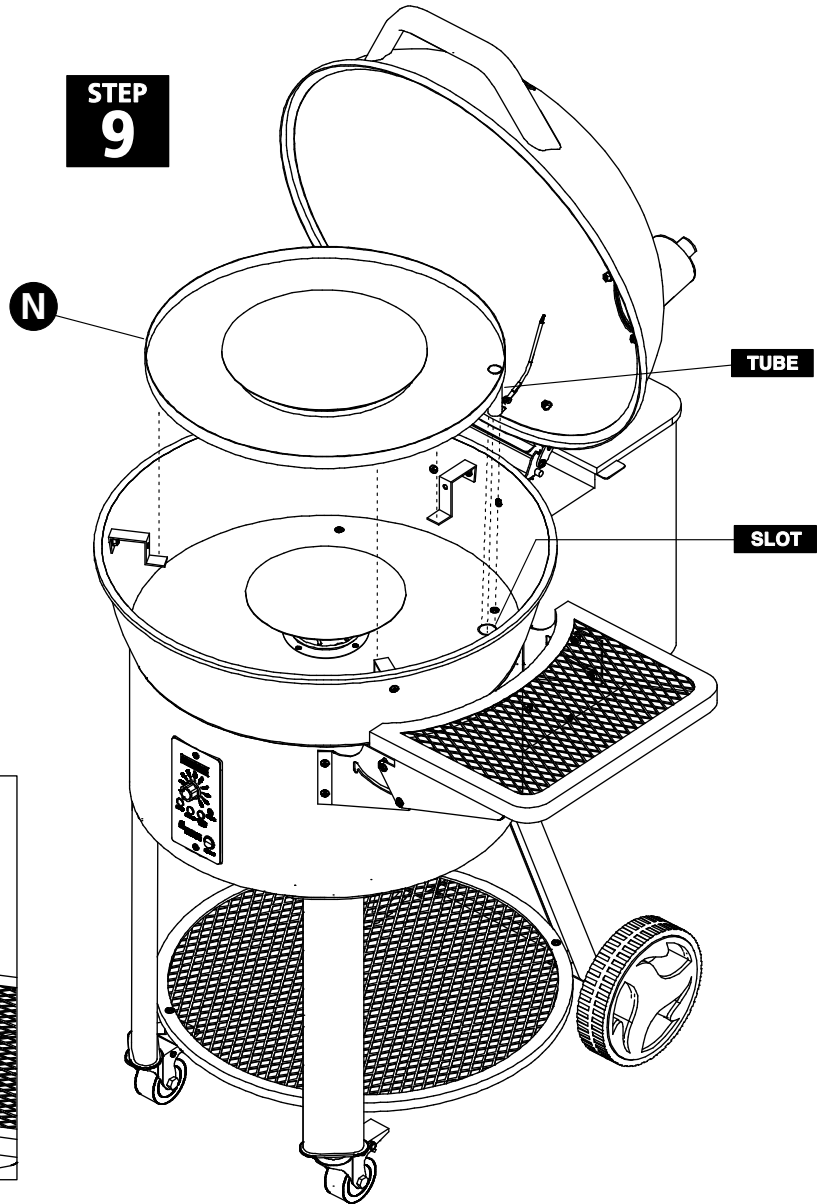

⚠ WARNING!
DO NOT OPERATE GRILL
WITHOUT THE HEAT
DIFFUSER OR DRIP TRAY
IN PLACE.

**DO NOT RETURN PRODUCT TO THE STORE.
IF YOU HAVE QUESTIONS OR HAVE
TROUBLE WITH ASSEMBLY, PLEASE CALL
1-877-347-4557 FOR ASSISTANCE.**

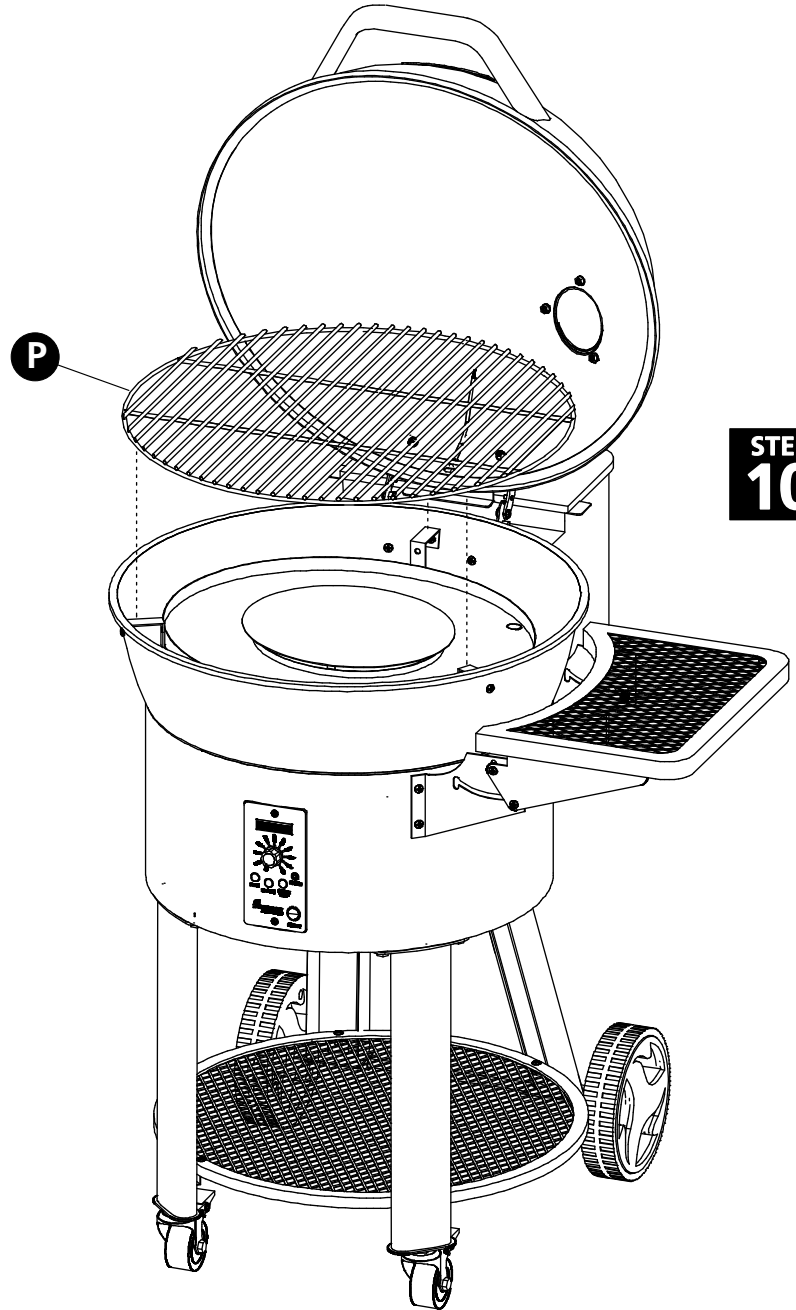

STEP 10: PLACE COOKING GRATE

Place the cooking grate [P] onto the holders. The bars should align with the front of the grill.

**STEP
10**

**DO NOT RETURN PRODUCT TO THE STORE.
IF YOU HAVE QUESTIONS OR HAVE
TROUBLE WITH ASSEMBLY, PLEASE CALL
1-877-347-4557 FOR ASSISTANCE.**

STEP 11: PLACE GREASE BUCKET

Hang the grease bucket [Q] on the hook located on the tube. The grease bucket must be used at all times.

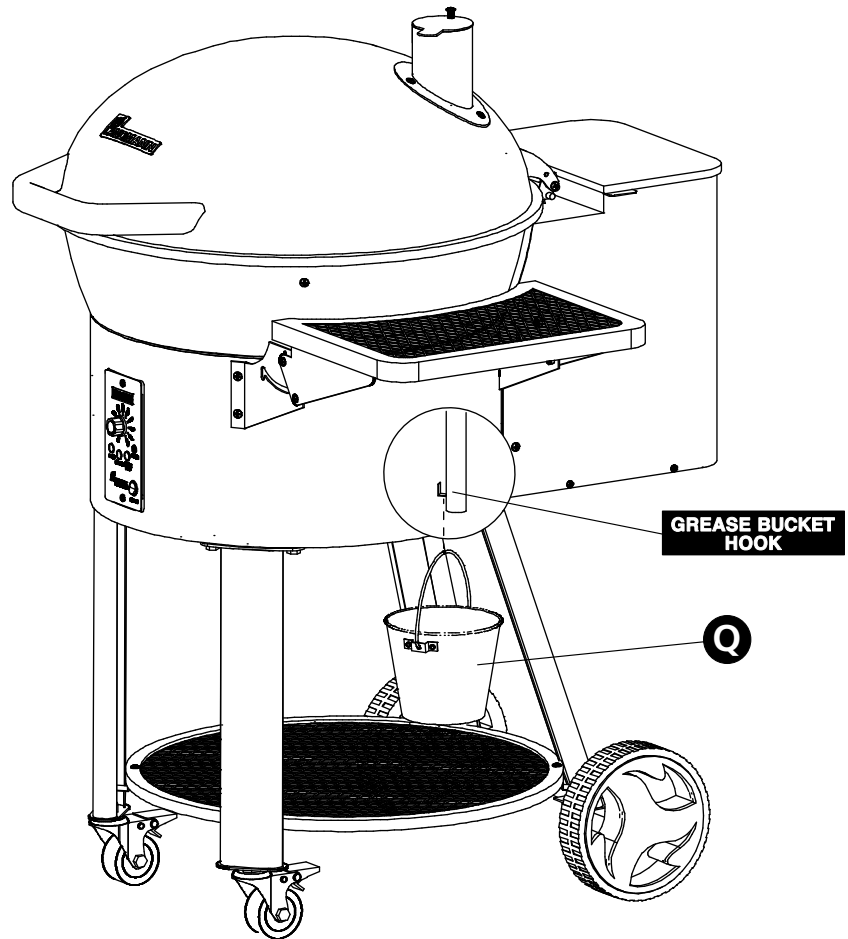

**STEP
11**

**DO NOT RETURN PRODUCT TO THE STORE.
IF YOU HAVE QUESTIONS OR HAVE
TROUBLE WITH ASSEMBLY, PLEASE CALL
1-877-347-4557 FOR ASSISTANCE.**

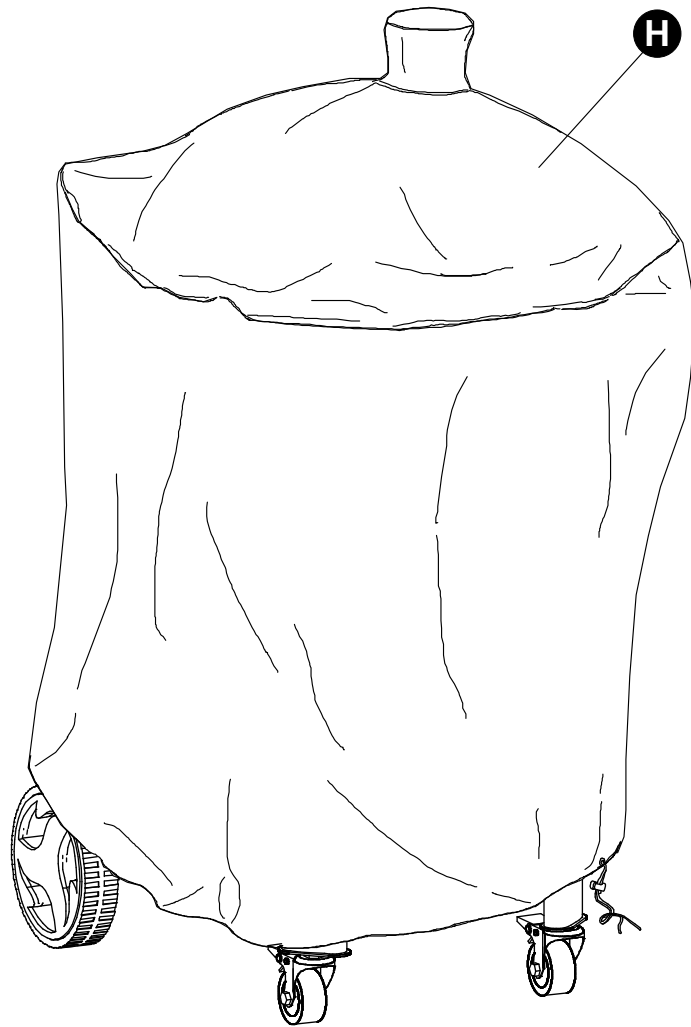

STEP 12: PLACE COVER

Fold the side shelf down. Place cover [H] on grill and use the pull strings to tighten. Keep the grill out of the weather and elements. Use cover only after the grill is completely cool to the touch.

**STEP
12**

**DO NOT RETURN PRODUCT TO THE STORE.
IF YOU HAVE QUESTIONS OR HAVE
TROUBLE WITH ASSEMBLY, PLEASE CALL
1-877-347-4557 FOR ASSISTANCE.**

OVERVIEW OF THE ASSEMBLED GRILL

These are the main components of the Pellet Kettle.

The Pellet Kettle uses an electrically powered auger and fan that is connected to a control panel to control the burning of fuel pellets for temperature and smoke.

■ Hopper lid

Open the hopper lid and add pellet fuel to the grill as needed. Keep the hopper lid closed at all times. Do not expose the pellets to any type of moisture or liquid.

■ Grill lid

This grill is designed to operate with the lid closed during use. The lid hinge has a built-in stop lock that keeps the lid open. To release, lift up on the handle to release.

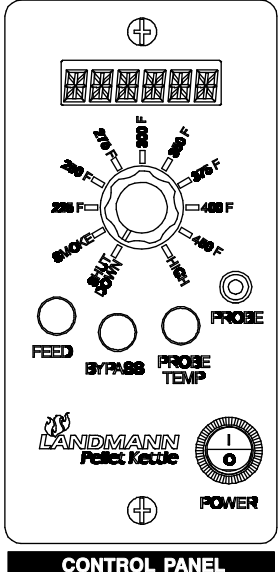
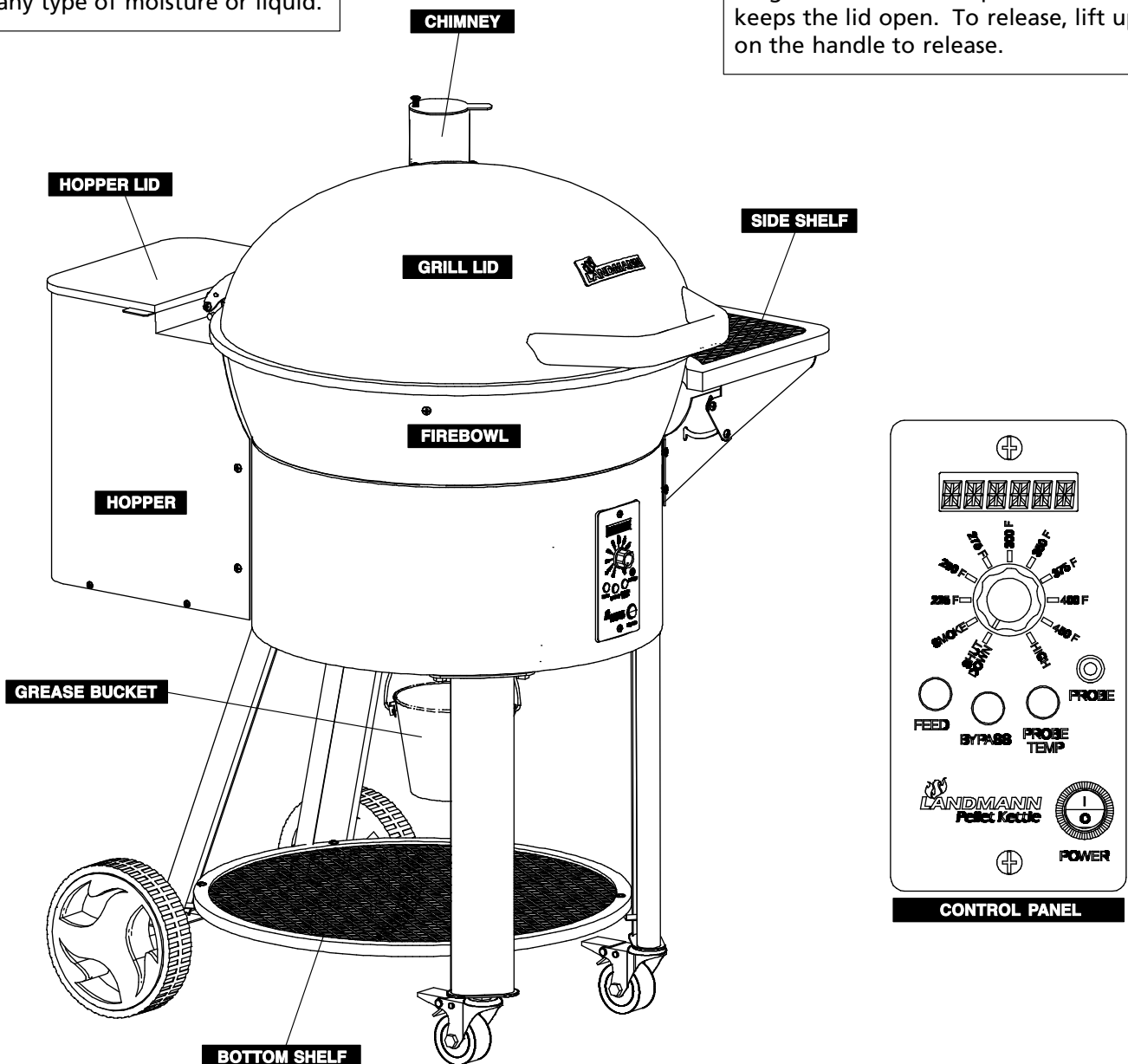

BE AWARE OF HOT AND MOVING PARTS

Inside the grill and hopper, there are moving parts and hot parts that the grill user must be aware of. Keep hands and fingers away from these parts.

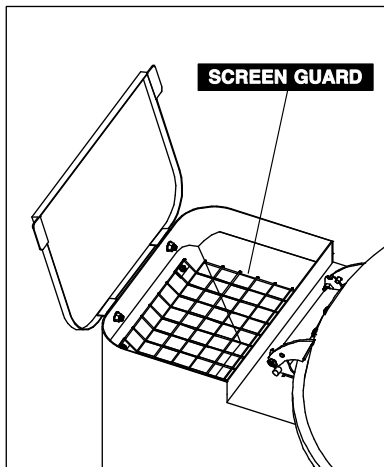

■ The hopper screen guard must be in place during use. If the screen is removed for cleaning, it must be put back in place prior to use. The screen guard is there to keep hands and fingers away from the auger.

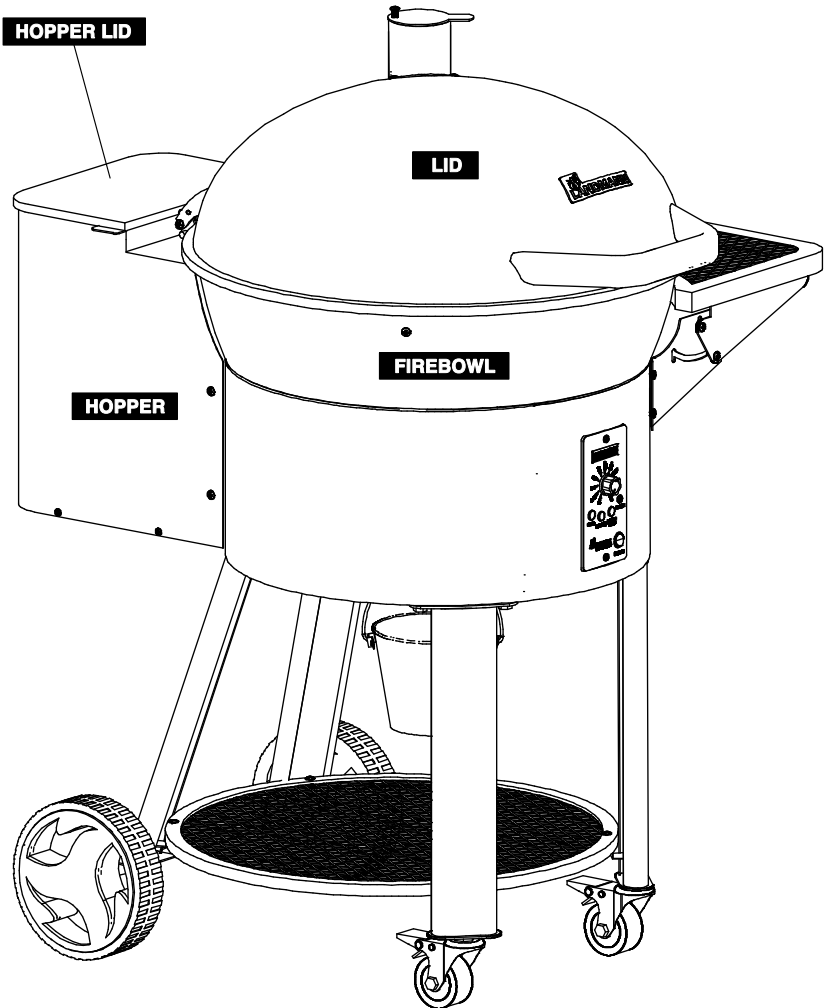

! DANGER!
ROTATING AUGER!
KEEP HANDS AND FINGERS AWAY.

AUGER

AUGER ON BOTTOM OF HOPPER

This panel contains a warning symbol of a hand being struck by a rotating auger. To the right is a diagram showing the auger at the bottom of the hopper.

! DANGER!
SHARP!
KEEP HANDS AND FINGERS AWAY FROM AUGER.

AUGER

IGNITOR ROD

FIRE POT ON BOTTOM OF FIREBOWL

This panel contains a warning symbol of a hand being struck by a sharp auger. To the right is a diagram showing the auger and ignitor rod inside the firebowl.

! HOT! WARNING!
NEVER TOUCH THE IGNITOR ROD. IT BECOMES EXTREMELY HOT AND WILL CAUSE SERIOUS BURNS.

This panel contains a warning symbol of a hand being struck by a hot ignitor rod.

CONTROL PANEL INTRODUCTION

1 6 DIGIT LED DISPLAY

Monitors current grill functions and status of the grill. Dual temperature monitor of setting and current temperatures.

2 10 SETTING CONTROL DIAL

Controls the grill temperature setting, rotate to setting desired. When the dial is turned to SHUT DOWN, the shut down mode begins. The fan will run for 8 minutes to burn off any remaining pellets in the fire pot.

3 FEED

Activate the auger by pressing and holding the FEED button for 3 seconds. Use this function to fill the auger with pellets for the first time the grill is used or anytime the grill runs out of pellets. The auger will run for 5 minutes.

4 BYPASS

If there is a power failure to the grill during use or the SHUT DOWN setting is accidentally selected during use, press and hold the BYPASS button for 3 seconds to bypass the normal startup mode of the grill when the power is returned. This applies only if the power was cut for only a short time. If the grill fails to ignite using the BYPASS mode, the grill will need to be restarted in the normal startup mode. The BYPASS button can also be used to cancel the FEED mode.

5 PROBE TEMP

When the meat probe is used, press button to have the food temperature displayed on the control panel. Press a second time to have the probe and grill temperatures toggle back and forth.

6 PROBE

Insert the plug end of the cord into control panel and the metal probe into the food to get the food temperature on the display.

7 POWER SWITCH

Turns the power to the grill on or off.

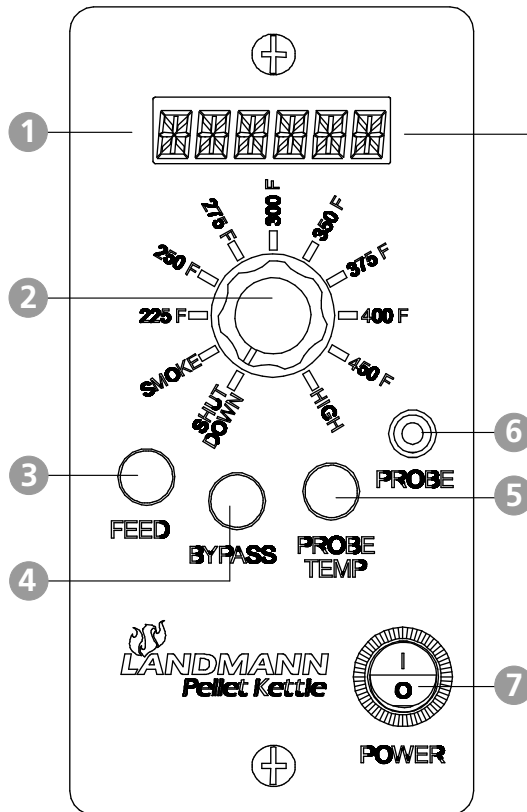

3 CYCLES FROM START TO FINISH

1. STARTUP CYCLE **START**
When the power button is pressed on and the dial is turned to any setting, the startup cycle is initiated. **START** will show in the display during the startup cycle. The auger and the fan will run. The ignitor rod will power on for 5 minutes to ignite the pellets in the fire pot. After 5 minutes, the ignitor rod turns off.

2. RUN CYCLE **255 F**
The auger and fan will always run depending on the temperature selected on the control panel. The fan and auger speed will vary depending on the temperature setting selected.

3. SHUT DOWN CYCLE **SDOWN**
When the control dial is turned to SHUT DOWN, **SDOWN** will display. This shuts down the auger and fuel supply but the fan continues to run for up to 8 minutes burning off any remaining fuel in the fire pot. This is a very important step in using your grill.

DISPLAY DEFINITIONS

- The power is on, the control dial is set to SHUT DOWN
- START** Will display during the startup cycle for 5 minutes
- SMOKE** Will display when the SMOKE setting is selected (170° - 225°F range)
- S 275 F** Grill temperature setting
- 315 F** Current grill temperature
- HIGH** Will display when the HIGH setting is selected (475° - 550°F range)
- P 150 F** Probe temperature reading
- SDOWN** Shutdown mode will run fan for 8 minutes
- FEED** Will display when the FEED cycle is running
- BPASS** Will display when the BYPASS function is selected
- []** (blank) SHUT DOWN cycle has completed with POWER button on

ERROR DISPLAY DEFINITIONS

- FLAME** Will display if the flame has gone out, the temperature has dropped below the setting for more than 10 minutes
- SENSR** The temperature sensor is not installed correctly or has a fault
- PRERR** The meat probe is not installed correctly

INITIAL FIRING INSTRUCTIONS

- Follow these instructions when the grill is going to be used for the first time.
- Follow these instructions anytime the grill runs out of pellets.

INITIAL FIRING

1. Make sure the grill is unplugged and the control dial is set to the SHUT DOWN position.
2. Remove the cooking grate, drip tray and heat diffuser from the firebowl and set aside. Observe there are no foreign objects in the firebowl or fire pot.
3. Open the hopper lid. Observe there are no foreign objects in the hopper or auger area.
4. Plug cord into a power outlet that is grounded for outdoor use, preferably a GFCI outlet.
5. Press the POWER switch on. The switch will light when on.
6. Turn the dial to SMOKE and check the following:
 - 1) Auger: look inside the hopper and see that the auger is turning.
 - 2) Fan: look inside the firebowl and place your hand over the fire pot to check for air coming from the fire pot.
Do not put your hands inside the fire pot!
 - 3) Ignitor Rod: after about 1 minute, the ignitor rod will become red hot and the air will become warm.
 - 4) If all of the above are observed, the grill is ready to be started.
7. Turn the dial to SHUT DOWN.

ADDING PELLETS

1. Fill the hopper with the desired amount grill fuel pellets. The hopper should be filled at least half way full.
2. Press and hold the FEED button for 3 seconds until FEED is displayed on the control panel. The auger motor will activate and fill the auger with pellets. The auger will move the pellets to the fire pot. The process takes around 5 minutes.
3. Turn the dial to SMOKE to startup the grill. Observe the pellets come to full flame. After the pellets have started burning fully, turn the dial to SHUT DOWN.
4. Allow the flame to extinguish, then carefully return the heat diffuser, drip tray and cooking grate to the firebowl.
5. The grill is ready to use.



■ Pellet fuel

Use pellet fuel that is labeled for grilling only. Wording such as grill or food grade will be printed on the pellet bag. Never use heating pellets. This type of pellet contains potentially hazardous contaminants. There are many flavors of pellets available each flavoring food a little differently. Use a high quality pellet fuel. Do not use pellets that have gotten wet. Do not use pellets that have become excessively powdery or dusty. This is a sign that the pellets are defective or have exposed to moisture at some time. Always store pellet fuel in a dry, clean and sealed container.

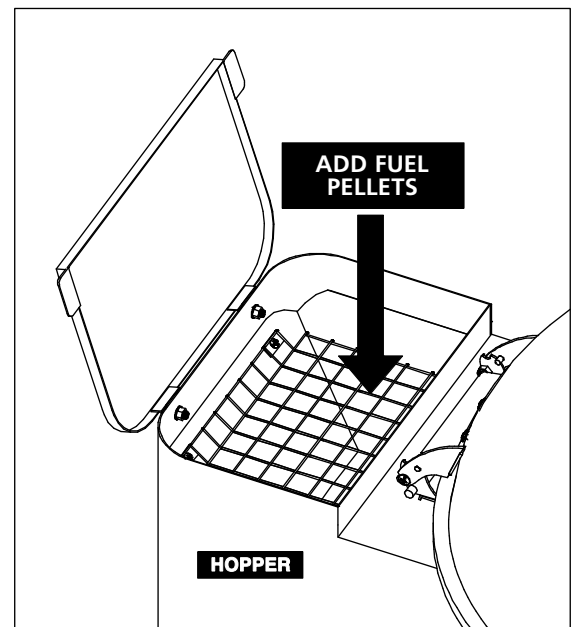

INITIAL SEASONING INSTRUCTIONS

■ Prior to first use, follow these steps to season your grill and rid the grill of any manufacturing residues and paint odor.

1. Open the lid, press POWER button on and turn the dial to SMOKE.
2. After a few minutes the pellets will ignite. When the pellets ignite, smoke will come from under the cooking grate.
3. Close the lid, open the lid vent to full open.
4. Turn the dial to HIGH and run for 1 hour.
5. After 1 hour, turn dial to SHUT DOWN.
6. The fan will continue to run for 8 minutes in the SHUT DOWN position.
7. When the fan shuts off, the grill is ready to use.

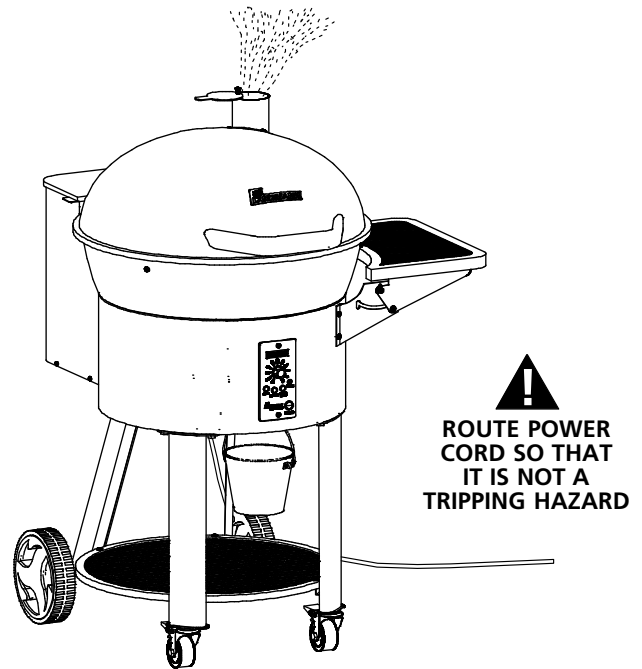

PELLET KETTLE OPERATING INSTRUCTIONS

WARNING !

This grill becomes very hot and possibly the handle. Use caution working around the grill. Use mittens or oven gloves when opening the lid or adjusting the vent during use.

1. Check the hopper and make sure there is sufficient fuel pellets.
2. Open the lid, press POWER button on and turn the dial to SMOKE.
3. After a few minutes the pellets will ignite with smoke coming from under the cooking grate.
4. Close the lid and open the vent to full open.
5. Set the temperature dial to any cooking temperature.
6. The display will indicate the temperature inside the grill at the cooking grate level.
7. Carefully wipe the cooking grate surfaces with vegetable oil to keep food from sticking.
8. When the desired temperature is reached, add meat and food to the cooking grate.
9. Cook food to your preference.
10. Keep an eye on the pellet level during use and add as needed.
11. **IMPORTANT!** When done using the grill, set the dial to SHUT DOWN. The grill will go into shut down mode. The auger will stop but the fan will continue running for up to 8 minutes. After 8 minutes, turn the POWER switch off.

This Pellet Kettle is very fuel efficient. A full hopper will be sufficient for most cookouts. However, be aware of the fuel pellet level and do not let the hopper run out of pellets. If it does run out, the auger will need to be reloaded. Refer back to the ADDING PELLETS section. The amount of fuel used at each setting is as follows:

FUEL INPUT RATING:			
SMOKE:	0.39 lb. / hr	350°F:	1.01 lb. / hr
225°F:	0.58 lb. / hr	375°F:	1.10 lb. / hr
250°F:	0.66 lb. / hr	400°F:	1.19 lb. / hr
275°F:	0.75 lb. / hr	450°F:	1.46 lb. / hr
300°F:	0.85 lb. / hr	HIGH:	1.76 lb. / hr

The hopper capacity is about 10 lbs.

HELPFUL OPERATING TIPS

1. The temperature setting can be adjusted at anytime during use. The grill will increase temperature faster than decrease.
2. The grilling temperature is sensitive to the climate it is being used in. If the outdoor temperature is hot, a lower setting may need to be used to reach the desired cooking temperature. If the outdoor temperature is cold, a higher setting may need to be used to reach the desired cooking temperature.
3. When the cooking is all done, it is important to first turn the control dial to SHUT DOWN. This shuts down the auger but the fan continues to run which will extinguish the remaining fuel in the fire pot. The fan will run for about 8 minutes. After 8 minutes, the display will go blank and the fan will turn off. Turn the POWER button to off.
4. The SMOKE setting temperature range is 170°-225°F. This setting best brings out the flavor of the pellets and is a slow cook setting.
5. The HIGH setting temperature range is 475° - 550°F. This range depends on the outdoor temperature and other conditions such as wind.
6. Maintaining the grill is the responsibility of the owner. The firebowl, drip tray and drip tray tube must be cleaned occasionally to remove grease buildup. Failure to clean grease buildup can cause grease fires which are very dangerous.
7. Never pour water into the firebowl, fire pot or drip tray.
8. If a grease fire were to occur, baking soda can be used to extinguish the fire. Use extreme caution not to burn yourself. If the fire does not extinguish, remove the food if possible. Keep the lid closed, close the chimney damper and press the power button to off. Once the fire is extinguished, clean the grease buildup before resume cooking.

FOOD TEMPERATURES

If you are unsure about when food is done, use this chart as a guide for measuring properly cooked meat temperatures.

Use the meat probe and meat probe function on the control panel to measure the meat temperature. Push probe into the thickest part of the meat to get an accurate measurement. Press the probe button and the food temperature will display on the control panel like this **P 150 F**.

The temperature reading on the control panel **315 F** measures the air temperature of the grill cooking chamber, not the food temperature.

Steaks & Roasts

Medium rare.....	145°F
Medium.....	160°F
Well done.....	170°F

Bison

Medium rare.....	145°F
Medium.....	160°F
Well done.....	170°F

Lamb

Medium rare.....	145°F
Medium.....	160°F
Well done.....	170°F

Ground Meats

Beef, Pork.....	160°F
Turkey.....	165°F

Pork

Medium.....	160°F
Well done.....	170°F

Poultry

Turkey.....	165°F
Chicken.....	165°F

Fish.....145°F

Egg Dishes.....160°F



FOOD SAFETY

- RAW MEAT AND POULTRY HAS TO BE KEPT SEPARATE FROM READY TO EAT FOOD.
- USE CLEAN PLATTERS AND UTENSILS FOR HANDLING COOKED FOODS.
- COOK POULTRY AND MEATS THOROUGHLY TO KILL BACTERIA.
- USE INSTANT-READ THERMOMETERS TO ENSURE PROPER INTERNAL FOOD TEMPERATURES.
- KEEP PREPARED FOOD AND LEFTOVERS REFRIGERATED.
- WASH HANDS, UTENSILS AND SURFACES WITH SOAP AND HOT WATER PRIOR TO AND AFTER HANDLING RAW MEAT AND POULTRY.

If you still have questions, please see the USDA contact info below.

USDA Meat and Poultry Hotline
1-888-674-6854
TTY: 1-800-256-7072
www.IsItDoneYet.gov

MAINTENANCE, GRILL CLEANUP AND STORAGE

All cleanup procedures are to be performed only while the smoker is turned off, completely cooled except where noted and unplugged from the electrical source.

■ After every use.

Clean the cooking grate with a cleaning tool while the grill is still warm. Check for grease and ash buildup. Empty the grease bucket.

■ Drip tray

The drip tray and surrounding areas should be cleaned periodically and checked for grease build-up. This buildup is easier to clean when the grill is still warm. It is not necessary to clean to the metal, just the excessive layering and buildup needs to be removed. Some grease is perfectly fine as it adds flavor to your food and protects the metal surfaces. Excessive grease buildup however, leads to grease fires which are very dangerous!

■ Ash

Ash from the burning pellets will eventually buildup inside the firebowl and should be periodically cleaned out. Remove the cooking grate and drip tray. Clean the bottom of the firebowl and the top of the heat diffuser with a damp (not wet) paper towel. Wipe clean. Do not push the ash into the fire pot.

■ Fire pot

After 20 hours of use, it is important to always carefully clean out and remove any ash buildup. Beware and stay clear of the auger which is sharp. **This is required maintenance and should always be done on a 20 hr. routine basis.**

■ Outside surfaces

The outside surfaces can be cleaned as needed using a soft sponge or rag and warm soapy water from a bucket. NEVER spray water from a pressurized hose at the grill. Do not use oven cleaner, abrasive or harsh chemicals on the paint surfaces. When cleaning the outside surfaces with water, it is extremely important to make sure NO water gets inside the hopper or the fire pot. Wood pellets expand when they get wet. Wet pellets will seize the auger and will damage the grill. Do not expose the control panel or the electrical components inside the hopper to water. All moisture should be wiped away and not allowed to stay on any surface of the grill. Always unplug the grill prior to cleaning.

■ Inspect

Frequently inspect and clean the grill for insects and insect nests. Inspect the power cord before each use to make sure it is in good condition. If there are signs of cuts or damage, do not use the grill until the cord is replaced or repaired.

■ Storage

Always unplug the grill after each use. Always use the included cover to protect the grill from the weather and elements. Store in a dry area if possible. The grill must be completely cooled off before any cover can be used.

TROUBLESHOOTING

PROBLEM	CAUSE	SOLUTION
FLAME	<ol style="list-style-type: none"> 1. Flame has gone out. 2. Temperature has dropped below setting for more than 10 minutes. 	<ol style="list-style-type: none"> 1. Verify there is a flame in the fire pot, if not turn the dial to SHUT DOWN and then to SMOKE in the same sequence to restart. 2. Verify there are pellets in the hopper and add pellets to the hopper if needed. 3. Press FEED to fill the auger. 4. Restart the grill.
SENSR	<ol style="list-style-type: none"> 1. Error with the temperature sensor. 	<ol style="list-style-type: none"> 1. Verify the temperature sensor is installed correctly. 2. Check the wiring around the probe for breaks or kinks. 3. Contact the manufacturer if the problem cannot be corrected.
PRERR	<ol style="list-style-type: none"> 1. Error with the meat probe. 	<ol style="list-style-type: none"> 1. Verify the plug is securely inserted into the probe socket on the control panel. 2. Contact the manufacturer if the problem cannot be corrected.
GRILL WILL NOT START	<ol style="list-style-type: none"> 1. The LED will not light up 	<ol style="list-style-type: none"> 1. Verify there is power to the grill and the grill is turned on. 2. The dial must be in one of the 10 operating positions (SMOKE-HIGH). 3. Contact the manufacturer if the problem cannot be corrected.
NO FLAME IN THE FIRE POT	<ol style="list-style-type: none"> 1. Will not heat up 	<ol style="list-style-type: none"> 1. Verify there are pellets in the hopper. 2. The dial must be in one of the 10 operating positions (SMOKE-HIGH). 3. Verify the ignitor rod is working. Turn dial to SHUT DOWN, then to SMOKE to verify ignitor rod becomes red hot. DO NOT TOUCH. 4. Verify fan is working. 5. Verify auger is working. 6. If any of these parts are not working, contact the manufacturer.
FIRE GOES OUT ON SMOKE SETTING	<ol style="list-style-type: none"> 1. Excess ash buildup in the fire pot 2. Windy environment 	<ol style="list-style-type: none"> 1. When the grill is cooled, remove the cooking grate, drip tray and heat diffuser to check fire pot for excess buildup. 2. If there is excess buildup of ash, carefully remove all ash and unburned pellets. 3. Replace parts and initiate startup. 4. Too much wind can extinguish the fire, move grill to a more protected area.

TROUBLESHOOTING

PROBLEM	CAUSE	SOLUTION
<p>NO PELLETS REACHING THE FIRE POT</p>	<p>1. Pellets not reaching the fire pot</p>	<p>1. Verify there are pellets in the hopper. 2. Verify auger is rotating. 3. If there are pellets in the hopper and the auger is turning, it may take up to 5 minutes for the pellets to reach the fire pot. 4. If the auger is not rotating, check the auger for jams and clear. 5. If the problem cannot be resolved contact the manufacturer.</p>
<p>GRILL DOES NOT REACH THE SET TEMPERATURE</p>	<p>1. Temperature will not reach the setting on the dial.</p>	<p>1. Keep the lid closed. 2. Adjust the damper on the chimney to more open or more closed. 3. Change the control dial to a higher or lower temperature setting. 4. Excessively hot, cold or windy conditions can keep the grill from reaching the desired setting. Move grill to a more protected area.</p>
<p>PELLETS BUILDUP IN FIRE POT AND DO NOT LIGHT IN FIRE POT</p>	<p>1. Pellets building up and fail to ignite.</p>	<p>1. Remove excess pellets and clean ash from the fire pot and ignitor rod area. 2. If the problem cannot be resolved contact the manufacturer.</p>
<p>LID HINGE STICKING AND POPPING</p>	<p>1. Lid hinge movement is not smooth.</p>	<p>1. Add cooking oil to the moving pins and pivoting bolts on the hinge. 2. If movement is still not smooth, check hexnuts to make sure they are not too tight. Lid movement should be without resistance.</p>

MAIN GRILL ASSEMBLY PARTS

MAIN GRILL ASSEMBLY PARTS QTY

E1. LID HINGE	1
E2. PELLET HOPPER HOUSING	1
E3. AUGER SCREEN GUARD	1
E4. PELLET HOPPER LID	1
E5. PELLET HOPPER BOTTOM SCREEN	1
E6. SIDE SHELF	1
AA. M6 x 12MM BOLT	17
AC. M6 FLANGE HEXNUT	5
AL. M4 x 10MM SCREW	8

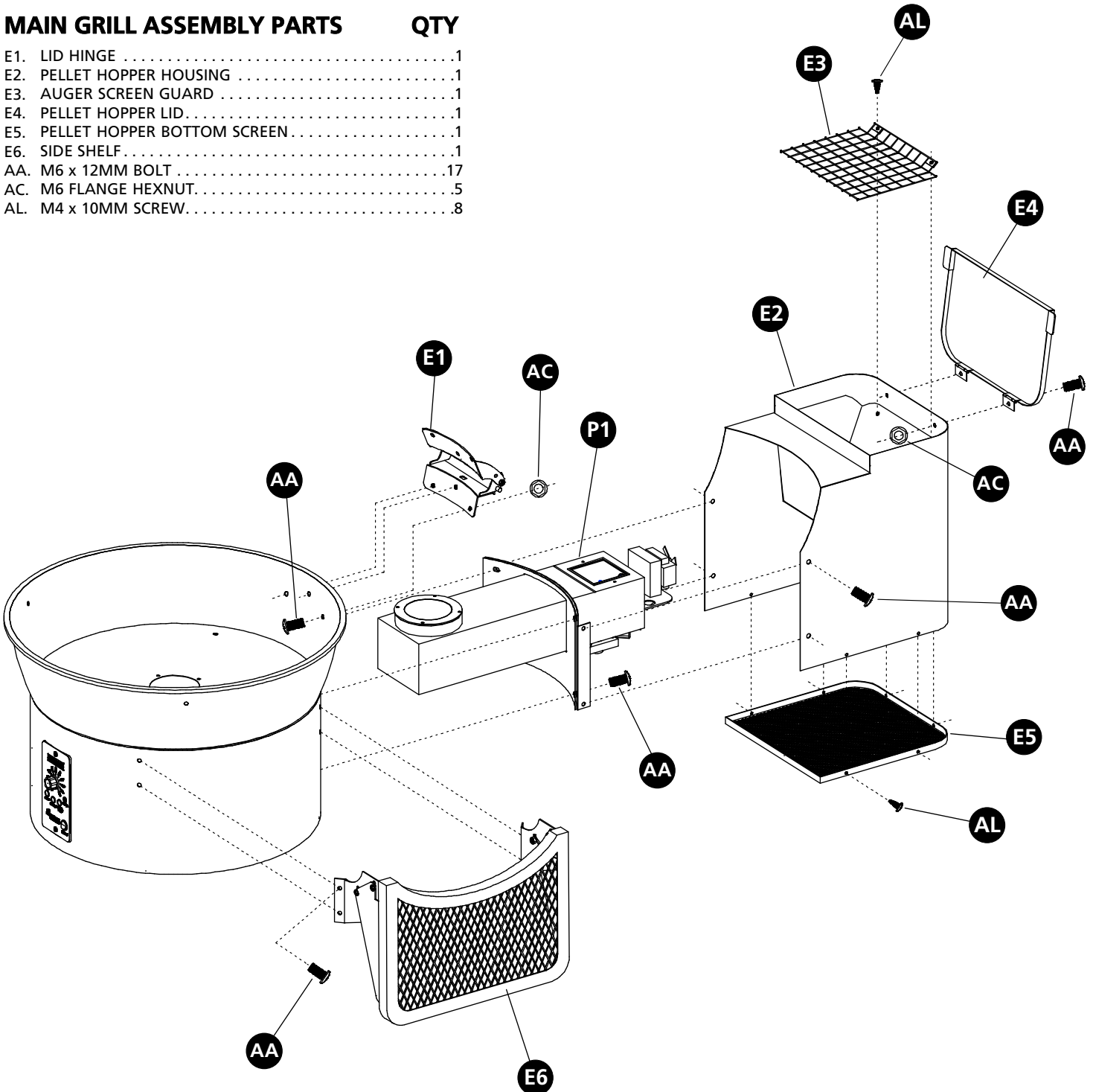

PELLET BURNER ASSEMBLY PARTS

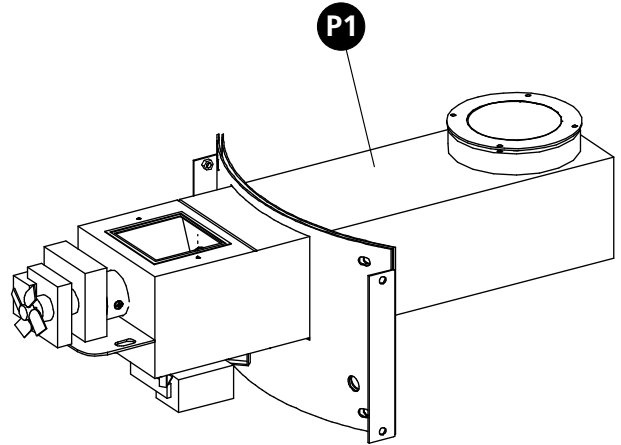

PELLET BURNER PARTS	QTY
P1. PELLET BURNER ASSEMBLY	1
P2. AUGER MOTOR ASSEMBLY	1
P3. AUGER HOUSING ASSEMBLY	1
P4. FIRE POT / IGNITOR ROD ASSEMBLY	1
P5. FAN MOTOR ASSEMBLY	1
AL. M4 x 10MM SCREW	11
AN. M4 x 10MM BOLT	1

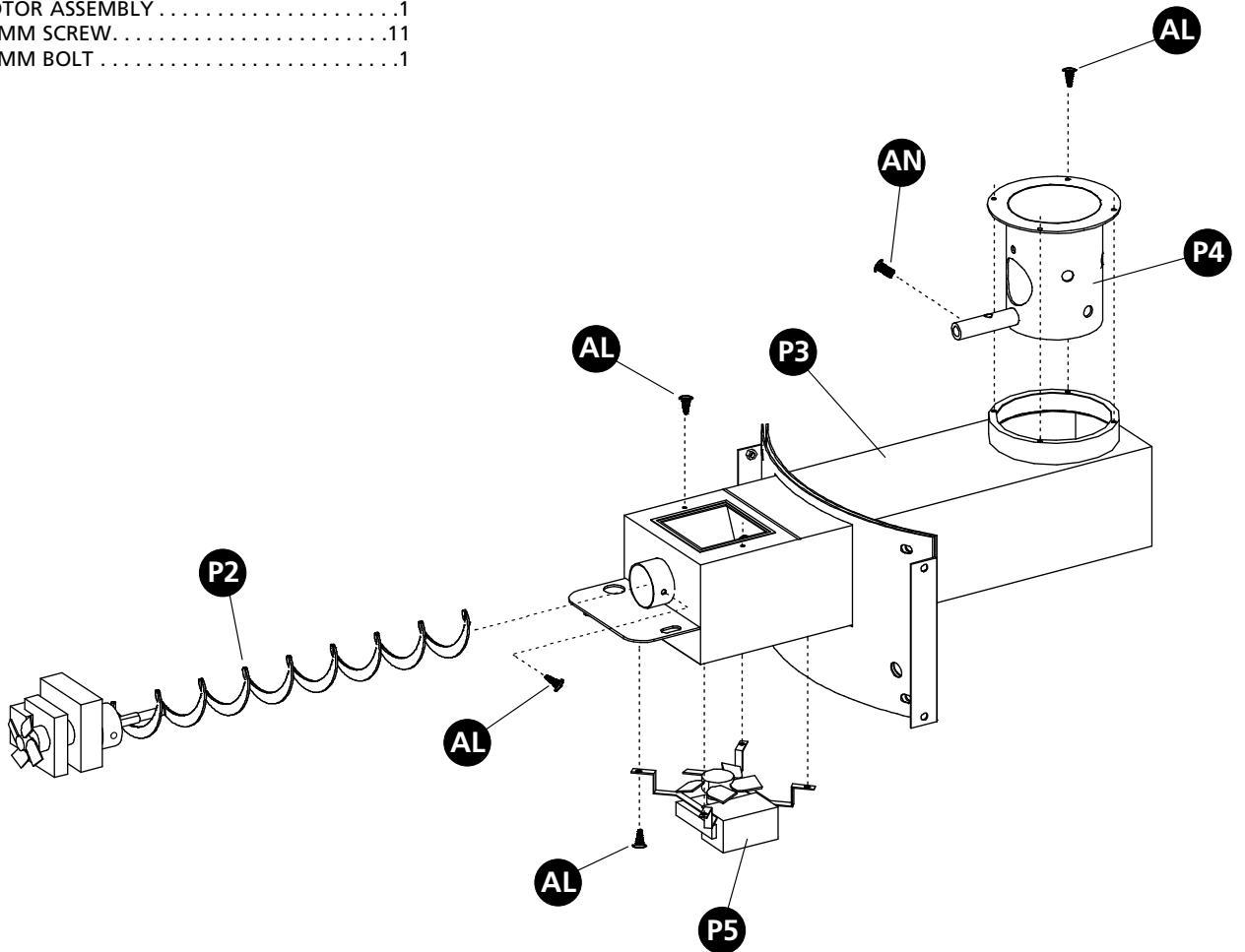

CONTROL PANEL WIRING DIAGRAM AND PARTS

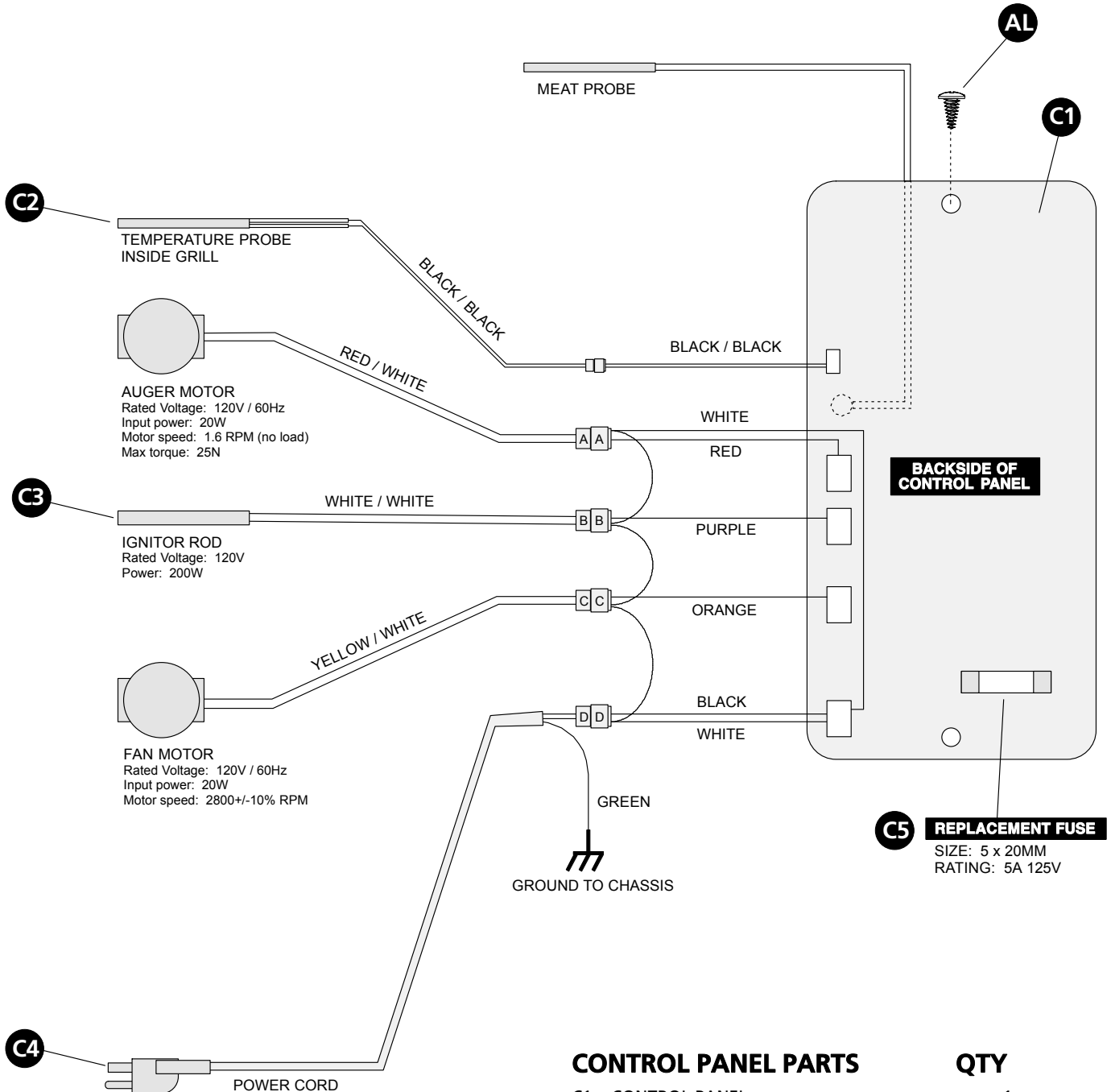

CONTROL PANEL PARTS	QTY
C1. CONTROL PANEL	1
C2. TEMPERATURE PROBE	1
C3. IGNITOR ROD	1
C4. POWER CORD	1
C5. REPLACEMENT FUSE	1
AL. M4 x 10MM SCREW	2

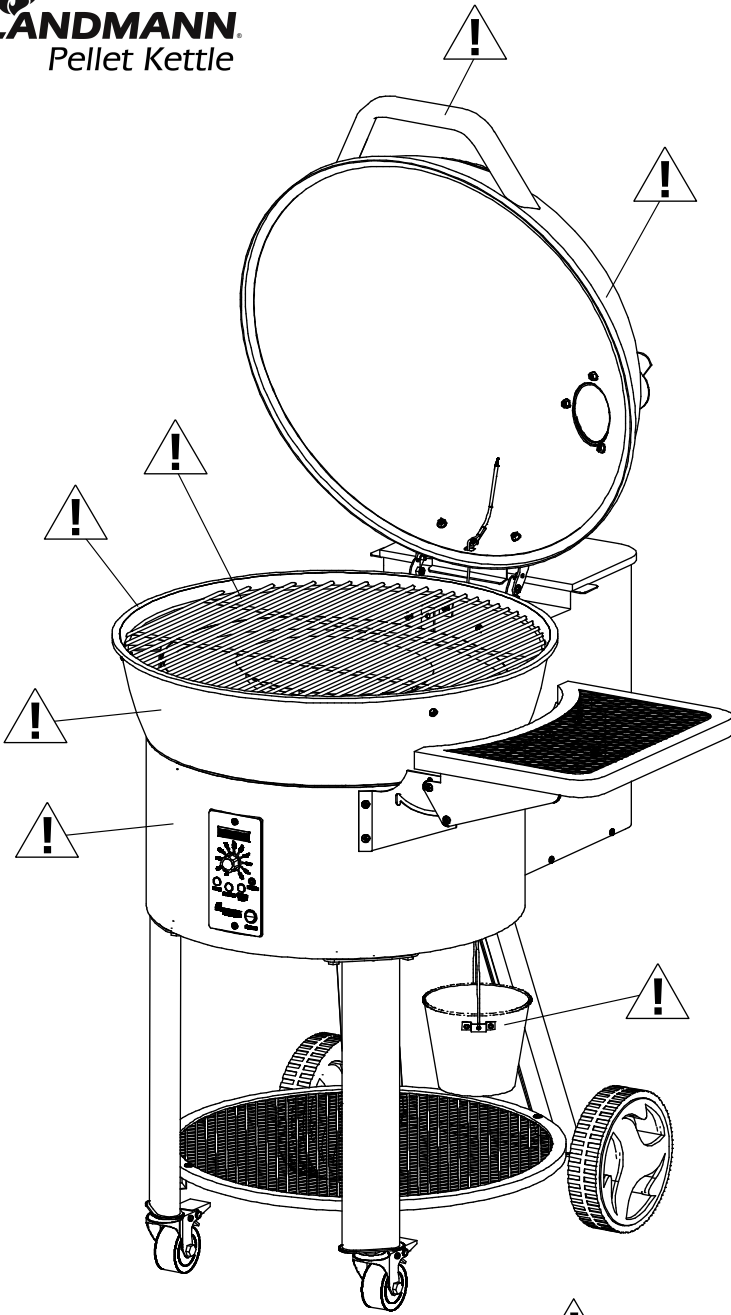

⚠ WARNING!
NEVER USE GASOLINE, ALCOHOL OR VOLATILE FLUIDS TO START OR RESTART FIRES IN THIS GRILL.

⚠ HOT!
⚠ WARNING!
HOT SURFACES DURING USE! USE MITTENS OR GLOVES ON THESE PARTS.

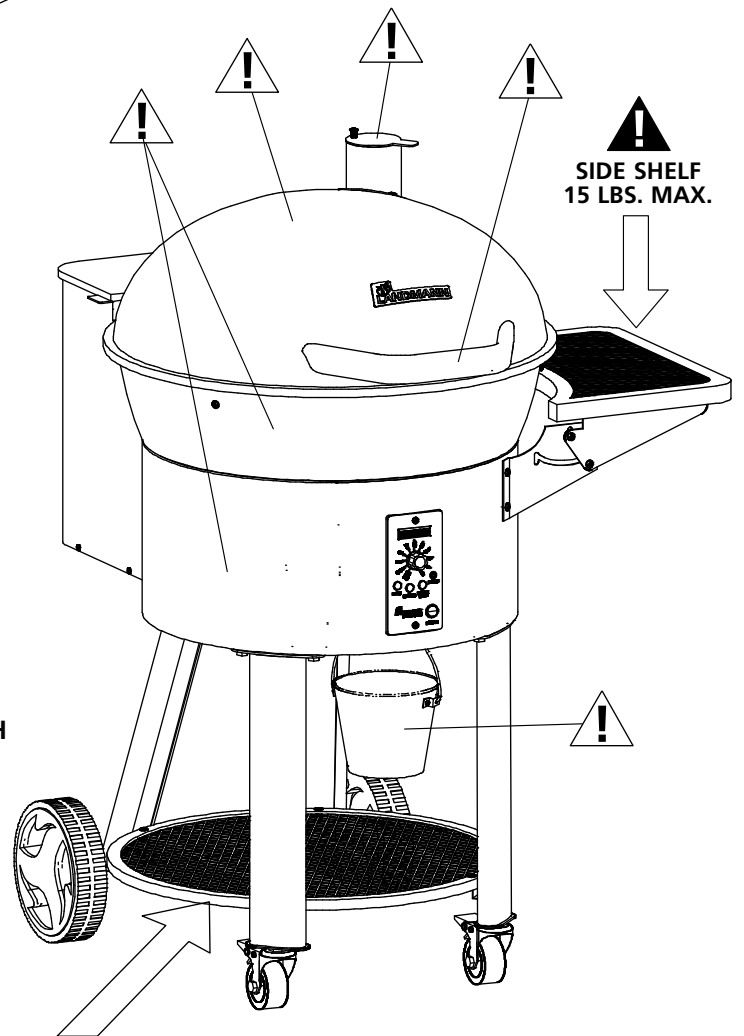

⚠
**HOT SURFACES DURING USE!
HANDLES BECOME WARM TO HOT WITH EXTENDED USE.**

⚠ DO NOT STORE FLAMMABLE MATERIALS ON THE STORAGE SHELF.

Congratulations on your purchase of the Pellet Kettle Grill! At Landmann USA, we strive to provide you with an easy to use, easy to assemble product. However, in the unlikely event your package should have a missing or defective part, please contact us at:
customerservice@landmann-usa.com
-OR-
1-877-347-4557 M-F 8-5 ET.
Proof of purchase may be required.
Thank you!

Please visit our website at:
www.landmann-usa.com
-OR-
Call customer service toll free at:
1-800-321-3473

Landmann® Limited
Distributed by Landmann® USA
Fairburn, GA 30213
www.landmann-usa.com
Made in China
© 2017 Landmann® USA



LIMITED WARRANTY

Landmann USA ("Landmann") warrants that this product shall be free of defects in material and workmanship to the original purchaser for 1 year. This limited warranty is made exclusively to the original customer presenting proof of purchase. This warranty is limited to non-commercial residential use only. Any returned goods must be shipped prepaid.

This warranty does not cover normal wear of parts or damage resulting from any of the following: negligence, abuse, misuse, alteration, improper installation, improper maintenance or failure to perform normal maintenance, or any use contrary to operating instructions. Furthermore, Landmann does not warrant in any way the weather cover, the finish of the product or cover damage or deterioration due to any normal or severe weather conditions or to any chemical exposure. These warranties do not cover surface scratches or heat damage, which is considered to be normal wear. These warranties exclude liability for any indirect, incidental consequential damages or loss of property of any nature.

Do not return product or any parts to the store or ship to the manufacturer without written authorization.

Contact Customer Service at: 1-877-3GRILLS (1-877-347-4557) or grills@landmann-usa.com. Any returned products or parts must be returned postage prepaid.

These warranties are limited to non-commercial residential use only.

Product repair or replacement as provided under this warranty is your exclusive remedy. Landmann shall not be liable for any incidental or consequential damages or breach of any express or implied warranty on this product or any part thereof, except to the extent prohibited by applicable law. Some states do not allow the exclusion or limitation of incidental or consequential damages, or allow limitation on how long an implied warranty lasts, therefore, the above limitation or exclusion may not apply to you. This warranty gives you specific legal rights, and you may also have other rights, which vary, from state to state.