

PELLET GRILL

Model number: CG2310601-MM-00

ASSEMBLY & OPERATING INSTRUCTIONS

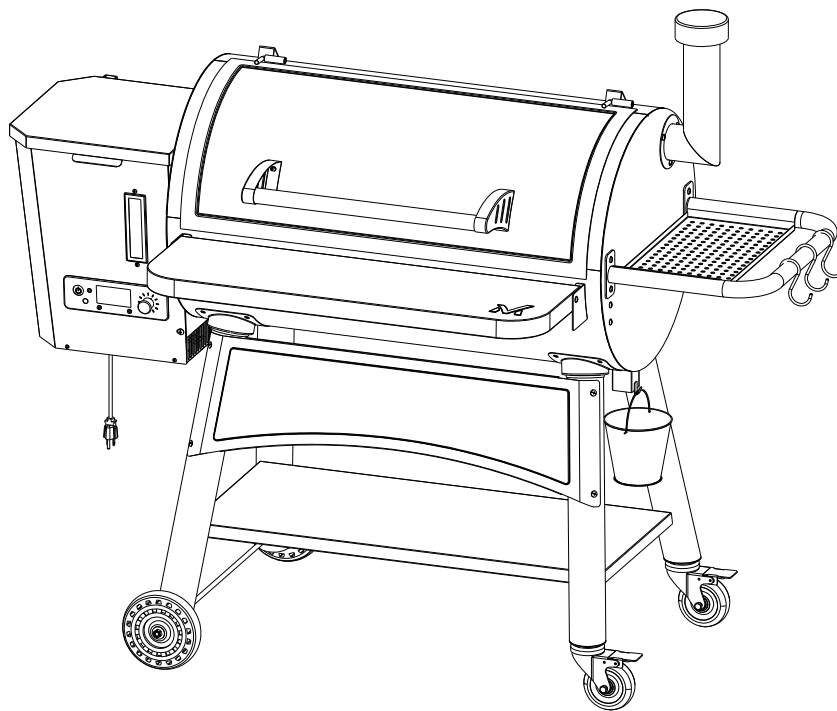

For Outdoor Use Only

- Please read this entire manual before installation and use of this pellet fuel-burning appliance.
- Follow all warnings and instructions when using the appliance.
- Failure to follow these instructions could result in property damage, bodily injury or even death.
- Contact local building or fire officials about restrictions and installation inspection requirements in your area.
- Save these instructions.

**Should you encounter any problem,
CALL US FIRST.**

**Do not return product to the store.
WE CAN HELP.**





For assistance, contact customer service at customerservice@rankam.com
or at **1-888-837-1380**, Mon to Fri, 8:00am – 5:00pm Pacific Standard time

WARNINGS

SAFETY LABELS

 **DANGER:** Indicates an imminent hazardous situation which, if not avoided, will result in death or serious injury.

 **WARNING:** Indicates a potentially hazardous situation which, if not avoided, could result in death or serious injury.

 **CAUTION:** Indicates a potentially hazardous situation which, if not avoided, may result in minor or moderate injury.



DANGER



1. Hazardous voltage is present which can shock, burn or cause death. Disconnect the power cord before servicing the grill unless otherwise noted in the owner's manual.
2. Never use or store flammable liquids near the grill.
3. Never use gasoline or lighter fluid to manually light your grill. Use only alcohol gel for this procedure and according to the instructions in the owner's manual.



DANGER



A MAJOR CAUSE OF FIRES IS FAILURE TO MAINTAIN REQUIRED CLEARANCES 60 INCHES TO COMBUSTIBLE MATERIALS. IT IS OF UTMOST IMPORTANCE THAT THIS PRODUCT BE INSTALLED ONLY IN ACCORDANCE WITH THESE INSTRUCTIONS.



PROP 65 WARNING



 **WARNING:** This product can expose you to chemicals including soot, which is known to the State of California to cause cancer, and carbon monoxide, which is known to the State of California to cause birth defects or other reproductive harm. For more information go to www.P65Warnings.ca.gov.



WARNING



Important Safety Instructions

When using electrical appliances, basic safety precautions should always be followed, including the following:

- READ ALL INSTRUCTIONS BEFORE INSTALLING AND USING THE APPLIANCE.
- This grill is for outdoor use only. Do not use it in any enclosed area.
- Use this appliance only on a level, stable surface to prevent tipping.
- Do not store or use combustible materials or liquids near this appliance.
- Maintain a long safe distance between your grill and any combustible.
- Do not move your grill while operating or while it is hot until the grill is completely cold.
- If a grease fire occurs, turn "off" and leave lid closed until the fire extinguished. Do not unplug the power cord. Do not throw water on it.
- Do not try to smother the fire.
- Clean and maintain your grill after each time use.
- Use Only Wood Pellet Fuel Specified By The Manufacturer. Do Not Use Pellet Fuel Labeled As Having Additives.
- Never use gasoline, gasoline-type lantern fuel, kerosene, charcoal lighter fluid, or similar liquids to start or 'freshen up' a fire in this appliance. Keep all such liquids well away from the appliance when in use.
- Seal and put the pellets in a dry place for storage when appliance is not in use.
- Remove pots and pans while the operating appliance is unattended, to reduce the risk of fire.
- Do not use accessories not specified for use with this appliance.
- Only **Dia 6 mm** Pellets can be used.
- Do not use your grill on rainy days.
- Do not touch any part of your grill directly while it is hot. Serious bodily injury could result.
- We suggest that use heat-resistant gloves when operating this grill.
- We suggest that you should warp Grease Drip Tray up with heavy-duty aluminum foil before using because it is easy to clean.
- For convenient and safe assembly, use at least two people to assemble the grill.
- Make sure the power cord is disconnected before performing any service or maintenance.
- Always keep the Pellet Hopper dry, the wood pellets will expand greatly, break apart and even jam the feed system if the pellets get wet or exposed to high humidity.
- Never use heating fuel pellets in the grill, due to potential hazardous contaminants and additives that may be present.
- Use your grill **OUTDOORS** in a well ventilated space away from dwellings or other buildings to prevent dangers associated with gas accumulation and toxic vapors. The grill should be situated at least 60 inches (152.4 cm) from buildings. Not adhering to these clearances will prevent proper ventilation and may increase the risk of a fire and/or property damage, which could also result in personal injury.

- Maintain a minimum clearance of 60 inches (152.4 cm) between all sides of grill, deck railings, walls or other combustible material. DO NOT use grill under any overhead combustible construction.
- To protect against electric shock, wear protective gloves such as oven mitts at all times when using appliance. Do not immerse cord, plugs or temperature controller in water or other liquid.
- Do NOT expose the appliance to rain or water at any time.
- Keep children and pets away from the appliance at all times. Do NOT allow children to use this appliance.
- Do NOT plug in the appliance until fully assembled and ready for use.
- Unplug the appliance from outlet when not in use or before cleaning. Allow appliance to cool down before putting on or taking off parts, and before cleaning.
- The appliance MUST be on the ground. Do NOT locate it on tables or counters. Do NOT move it across uneven surfaces.
- Use only approved and grounded electrical outlet.
- Keep a fire extinguisher accessible while using the appliance.
- Do NOT use fuel, such as charcoal briquettes or heat pellets for in this appliance.
- Be careful when removing food from the appliance. All surfaces are HOT and may cause burns.
- Do NOT allow anyone to conduct activities around the appliance during or following its use until the unit has cooled.
- Do NOT use appliance when under the influence of alcohol, prescription or non-prescription drugs.
- Do NOT use this appliance as a heater.
- Remove the label on the lid before first use.

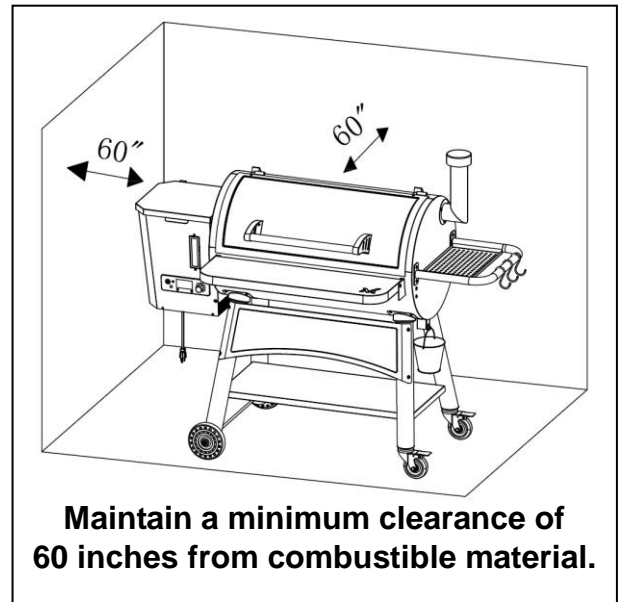



WARNING



When using electrical appliances, basic safety precautions should always be followed, including the following:

- Electrical Rating: 120 Volts / 60 Hz / 250W, Phase 1.
- Must be electrically grounded in accordance with local codes or, in the absence of local codes, with the National Electrical Code, ANSI/NFPA 70, or the Canadian Electrical Code, Part I, CSA C22.1 when install this appliance.
- Keep any electrical supply cord and the fuel supply hose away from any heated surfaces.
- To protect against electric shock, do not immerse cord or plugs in water or other liquid.
- Unplug from the outlet when not in use and before cleaning. Allow to cool before putting on or taking off parts.
- Do not let the cord hang over the edge of a table or touch hot surfaces.
- Never remove the grounding plug or use with an adapter of 2 prongs.
- Use only extension cords with a 3-prong grounding plug, rated for the power of the equipment, and approved for outdoor use with a W-A marking.



WARNING



Follow these guidelines to prevent this colorless, odorless gas from poisoning you, your family or others.

- Know the symptoms of carbon monoxide poisoning: headache, dizziness, weakness, nausea, vomiting, sleepiness, and confusion. Carbon monoxide reduces the blood's ability to carry oxygen. Low blood oxygen levels can result in loss of consciousness and death.
- See a doctor if you or others develop cold or flu-like symptoms while cooking or in the vicinity of this appliance. Carbon monoxide poisoning, which can easily be mistaken for a cold or flu, is often detected too late.
- Alcohol consumption and drug use increase the effects of carbon monoxide poisoning. Carbon monoxide is especially toxic to mother and child during pregnancy, infants, the elderly, smokers, and people with blood or circulatory system problems, such as anemia, or heat disease.



WARNING



Contact local building or fire officials about restrictions and installation inspection requirements in your area.



WARNING



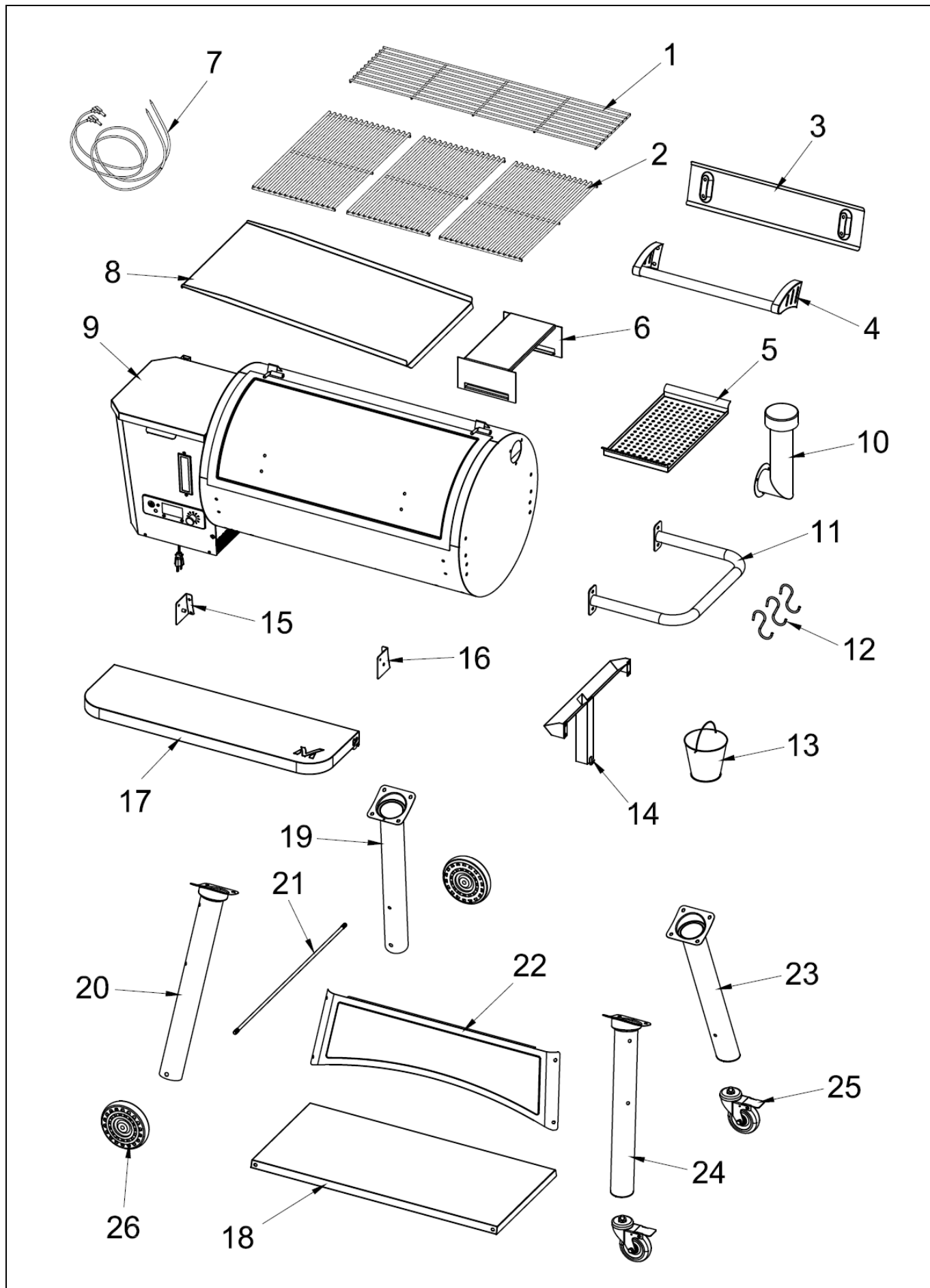

- Creosote - Formation and need for removal. When wood pellets are burned slowly, they produce tar and other organic vapors that combine with expelled moisture to form creosote. The creosote vapors condense in a relatively cool oven flue and exhaust hood of a slow burning fire. As a result, creosote residue accumulates on the flue lining and exhaust hood. When ignited, this creosote makes an extremely hot fire.
- The grease duct should be inspected at least twice a year to determine when grease and/or creosote buildup has occurred.
- When grease or creosote has accumulated, it should be removed to reduce risk of fire.
- Disposal of ashes - Ashes should be placed in a metal container with a tight-fitting lid. The closed container of ashes should be placed on a non-combustible floor or on the ground, well away from all combustible materials, pending final disposal. When the ashes are disposed by burial in soil or otherwise locally dispersed, they should be retained in the closed container until all cinders have thoroughly cooled.
- **SAVE THESE INSTRUCTIONS.**

PRODUCT DIAGRAM



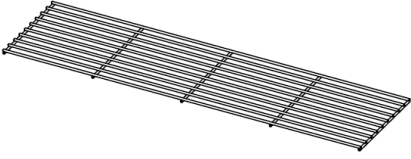
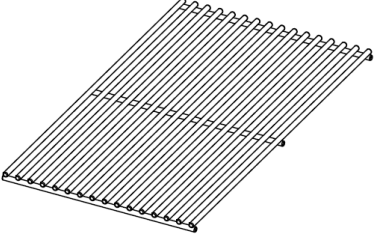
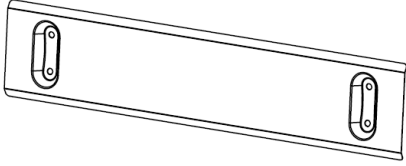
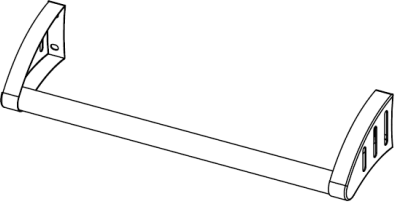
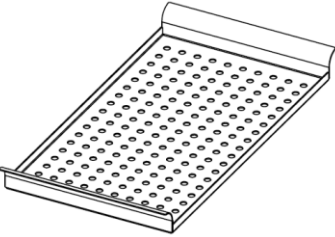
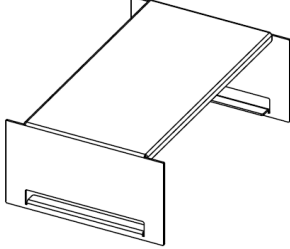
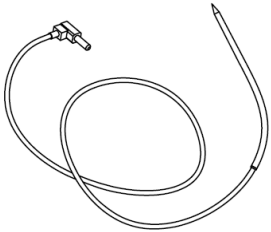
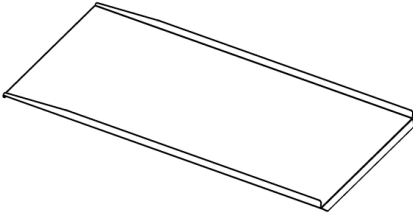
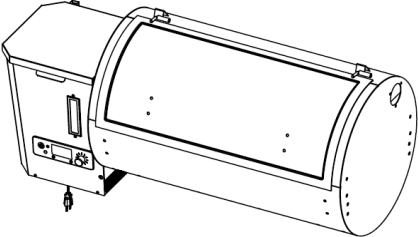
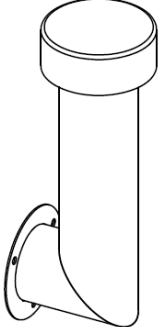
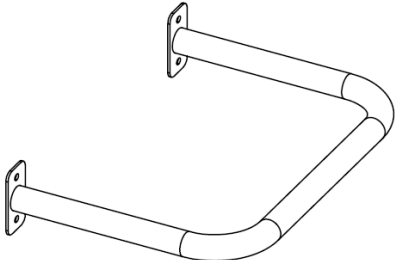
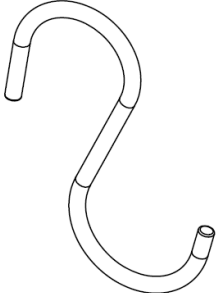

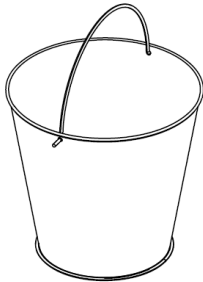
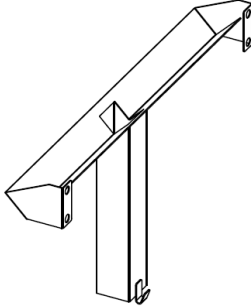
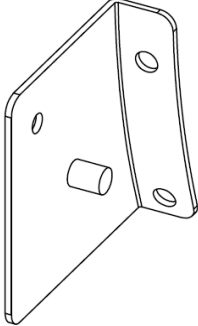
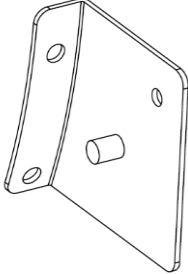
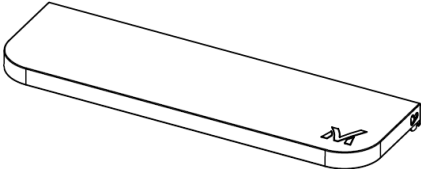
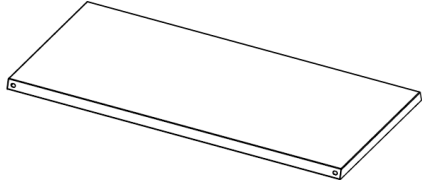
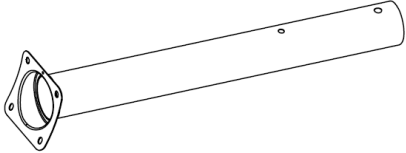
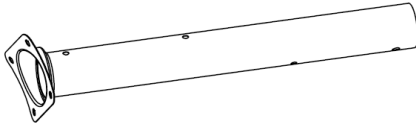

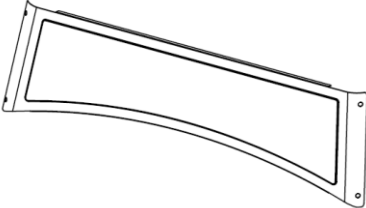
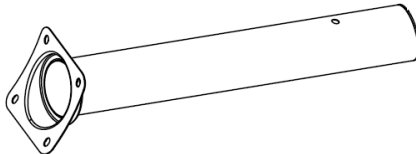
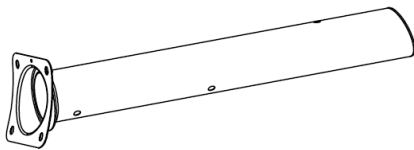
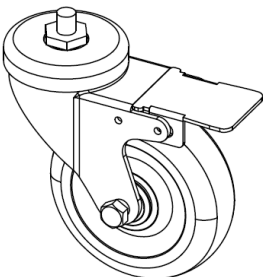
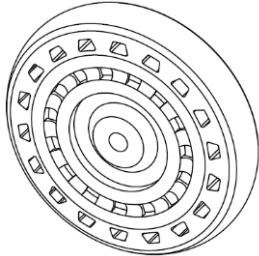
COMPONENT LIST

<p>1. Warming Rack</p>  <p>Qty: 1pc</p>	<p>2. Cooking Grate</p>  <p>Qty: 3pcs</p>	<p>3. Lid Handle Heat Shield</p>  <p>Qty: 1pc</p>
<p>4. Lid Handle</p>  <p>Qty: 1pc</p>	<p>5. Side Handle Tray</p>  <p>Qty: 1pc</p>	<p>6. Flame Tamer</p>  <p>Qty: 1pc</p>
<p>7. Meat Probe</p>  <p>Qty: 2pcs</p>	<p>8. Grease Drip Tray</p>  <p>Qty: 1pc</p>	<p>9. Grill Body Assembly</p>  <p>Qty: 1pc</p>
<p>10. Smoke Stack Assembly</p>  <p>Qty: 1pc</p>	<p>11. Side Handle</p>  <p>Qty: 1pc</p>	<p>12. Hook</p>  <p>Qty: 3pcs</p>

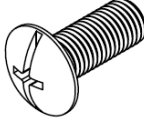
<p>13. Grease Bucket</p>  <p>Qty: 1pc</p>	<p>14. Grease Drain Assembly</p>  <p>Qty: 1pc</p>	<p>15. Front Shelf Left Bracket</p>  <p>Qty: 1pc</p>
<p>16. Front Shelf Right Bracket</p>  <p>Qty: 1pc</p>	<p>17. Front Shelf</p>  <p>Qty: 1pc</p>	<p>18. Cart Bottom Panel</p>  <p>Qty: 1pc</p>
<p>19. Left Rear Leg</p>  <p>Qty: 1pc</p>	<p>20. Left Front Leg</p>  <p>Qty: 1pc</p>	<p>21. Wheel Axle</p>  <p>Qty: 1pc</p>
<p>22. Cart Front Panel</p>  <p>Qty: 1pc</p>	<p>23. Right Rear Leg</p>  <p>Qty: 1pc</p>	<p>24. Right Front Leg</p>  <p>Qty: 1pc</p>
<p>25. Locking Caster</p>  <p>Qty: 2pcs</p>	<p>26. Wheel</p>  <p>Qty: 2pcs</p>	

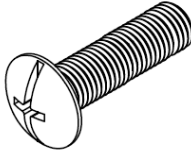
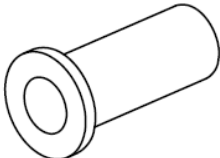
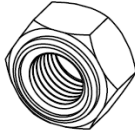
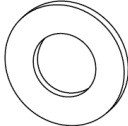
HARDWARE LIST

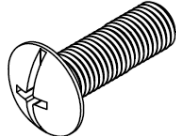
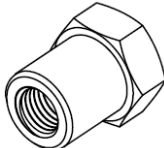
Item No.	Item name	Diagram	Qty
A	M6x12mm Bolt		39
B	M6 Nut		11
C	M6x20mm Bolt		2
D	Wheel Sleeve		2
E	M10 Locking Nut		2
F	M10 Washer		2
G	Heat Insulating Washer		4
H	M6x14mm Bolt		4
I	M6x15 Nut		2

Symbol: The following symbols will be shown in each procedure to show how the nut and bolt should be tightened.

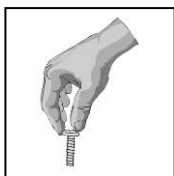

Hand Tighten



Tighten with tools



WARNING



- Please wear gloves while assembling the grill.

Replacement Part List (I)

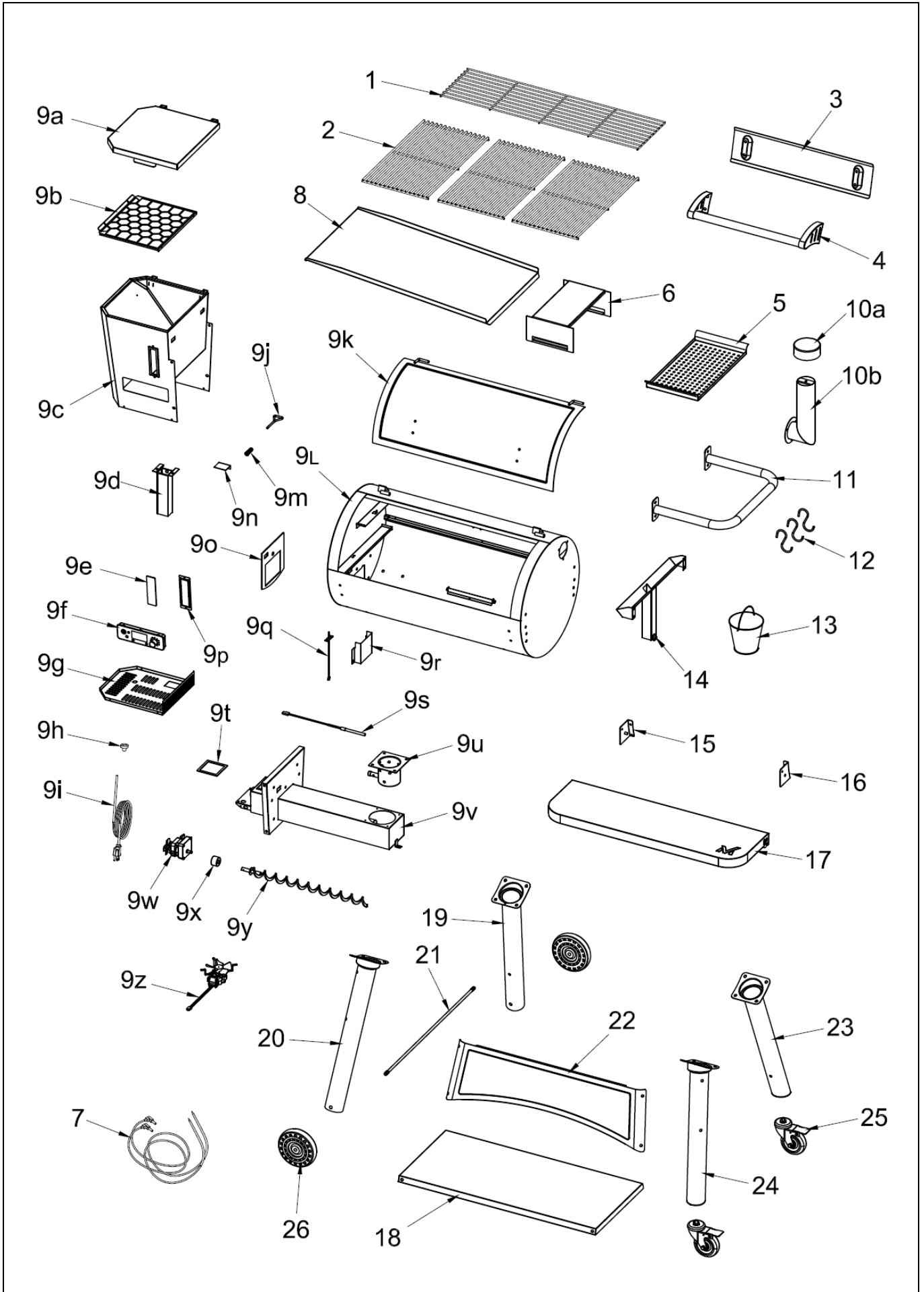

Replacement Part List (II)

Part Number	Part Name	Part Number	Part Name
1	Warming Rack	2	Cooking Grate
3	Lid Handle Heat Shield	4	Lid Handle
5	Side Handle Tray	6	Flame Tamer
7	Meat Probe	8	Grease Drip Tray
9	Grill Body Assembly	9a	Grill Body – Hopper Lid
9b	Grill Body – Hopper Guard	9c	Grill Body – Hopper Body
9d	Grill Body – Pellet Extractor Tube	9e	Grill Body – PVC Plate
9f	Grill Body – Control Panel	9g	Grill Body – Hopper Bottom Panel
9h	Grill Body – Power Cord Bushing	9i	Grill Body – Power Cord
9j	Grill Body – Pellet Extractor Handle	9k	Grill Body – Lid
9l	Grill Body – Firebox Body	9m	Grill Body – Pellet Extractor Spring
9n	Grill Body – Pellet Extractor Plate	9o	Grill Body – Feeder Sealing Ring
9p	Grill Body – PVC Fixing Bracket	9q	Grill Body – RTD Sensor
9r	Grill Body – RTD Sensor Cover	9s	Grill Body – Hot Rod
9t	Grill Body – Hopper Sealing Ring	9u	Grill Body – Pellet Firepot
9v	Grill Body – Feeder Assembly	9w	Grill Body – Auger Drive Motor
9x	Grill Body – Auger Seal Ring	9y	Grill Body – Auger
9z	Grill Body – Draft Inducer Fan	10	Smoke Stack Assembly
10a	Smoke Stack Cover	10b	Smoke Stack
11	Side Handle	12	Hook
13	Grease Bucket	14	Grease Drain Assembly
15	Front shelf Left Bracket	16	Front Shelf Right Bracket
17	Front Shelf	18	Cart Bottom Panel
19	Left Rear Leg	20	Left Front Leg
21	Wheel Axle	22	Cart Front Panel
23	Right Rear Leg	24	Right Front Leg
25	Locking Caster	26	Wheel

ASSEMBLY PROCEDURES

Step 1. Attach the **Legs (19, 20, 23 & 24)** to the **Grill Body Assembly (9)** using 16 pcs bolt (A) as shown below. Please make sure that all the legs are in right position and direction.

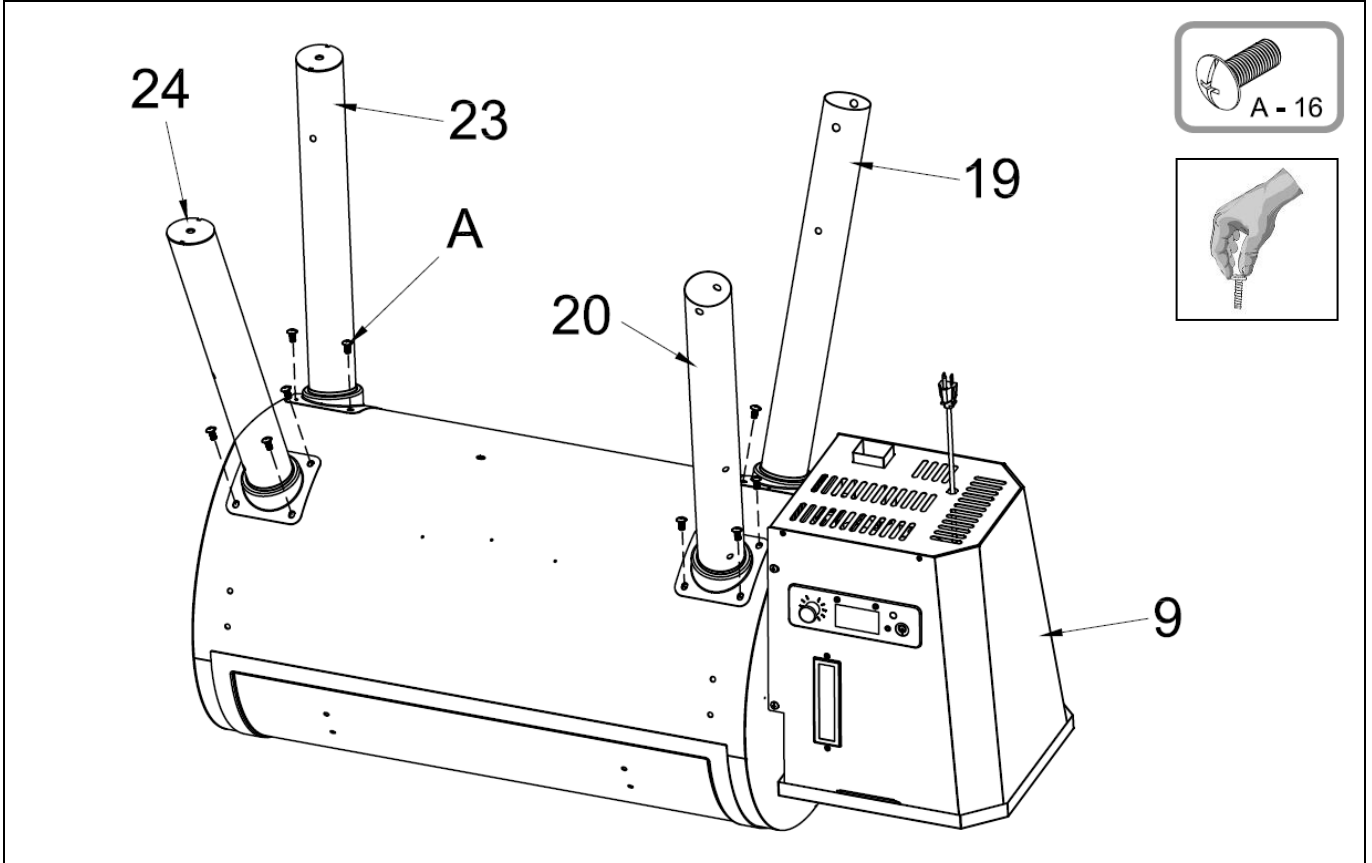

Step 2. Attach the **Cart Bottom Panel (18)** to the legs using 4 pcs bolt (A).

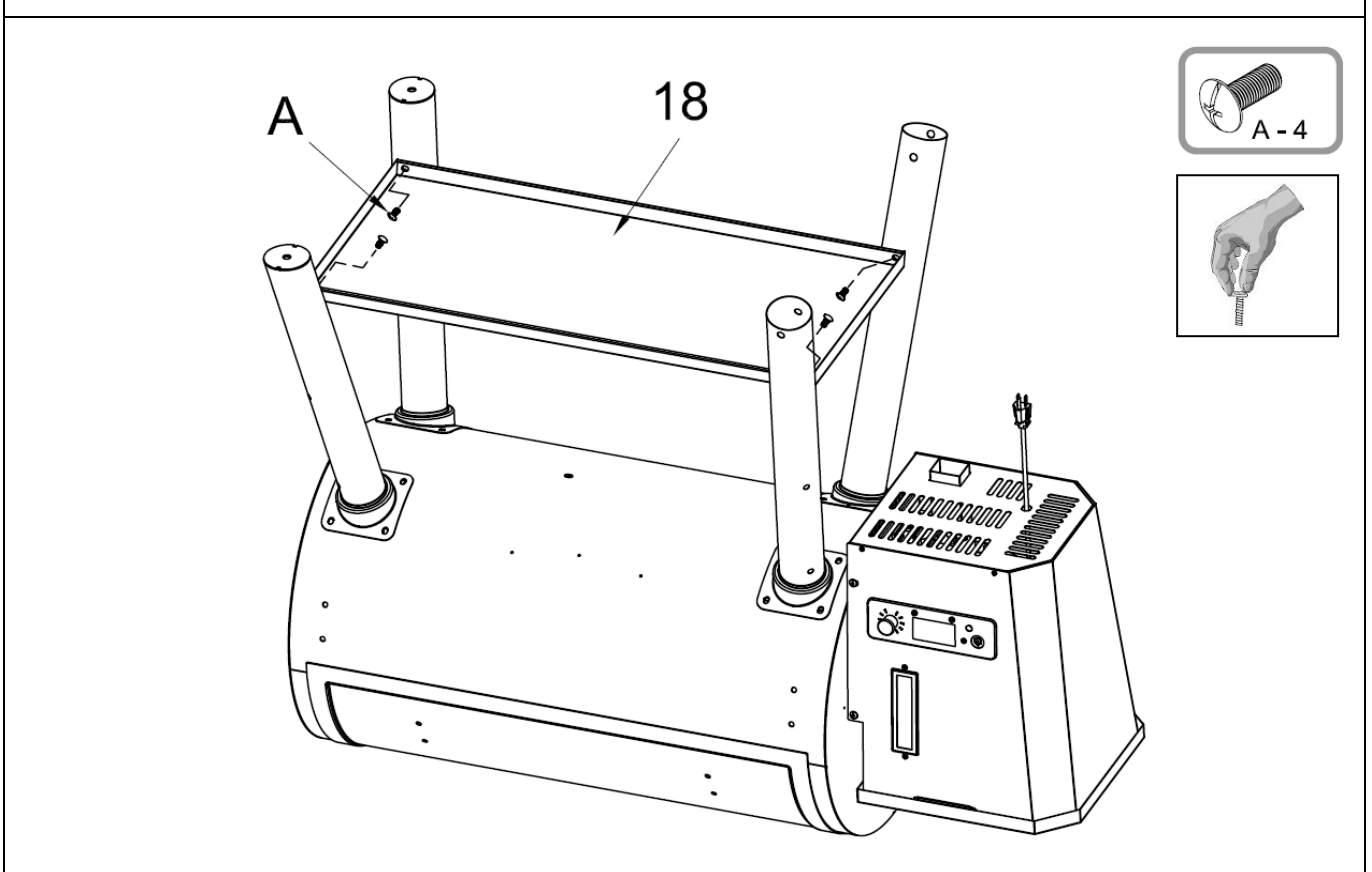

Step 3. Lock the **Locking Casters (25)** then insert them into the threaded holes on the bottom of the right legs as shown. Tighten the caster by turning in clockwise until it is fully secured.

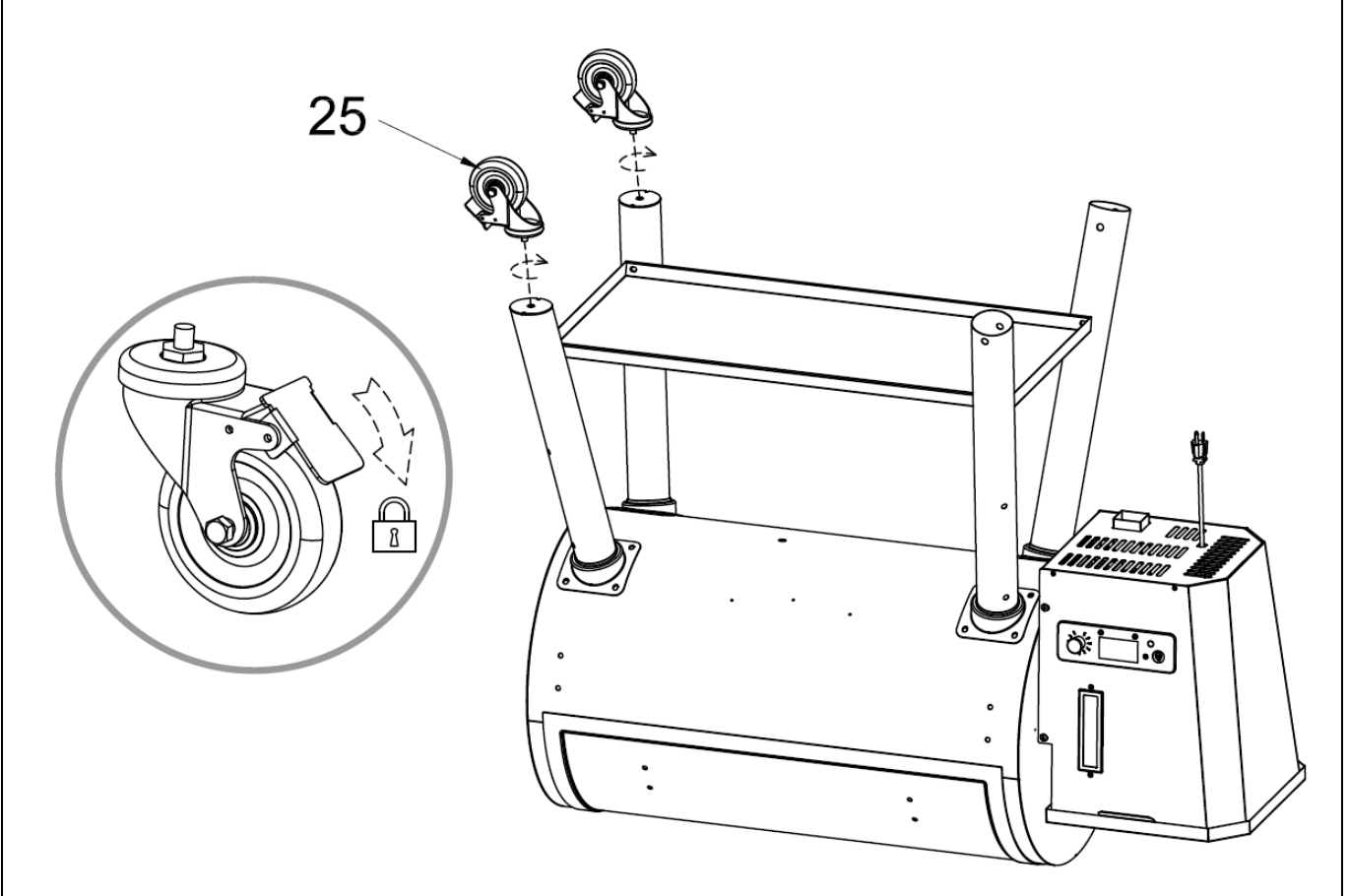

Step 4. Attach the **Wheels (26)** and **Wheel Axles (21)** to the left legs using 2 sets wheel sleeves (D), washers (F) and bolts (E) as shown.

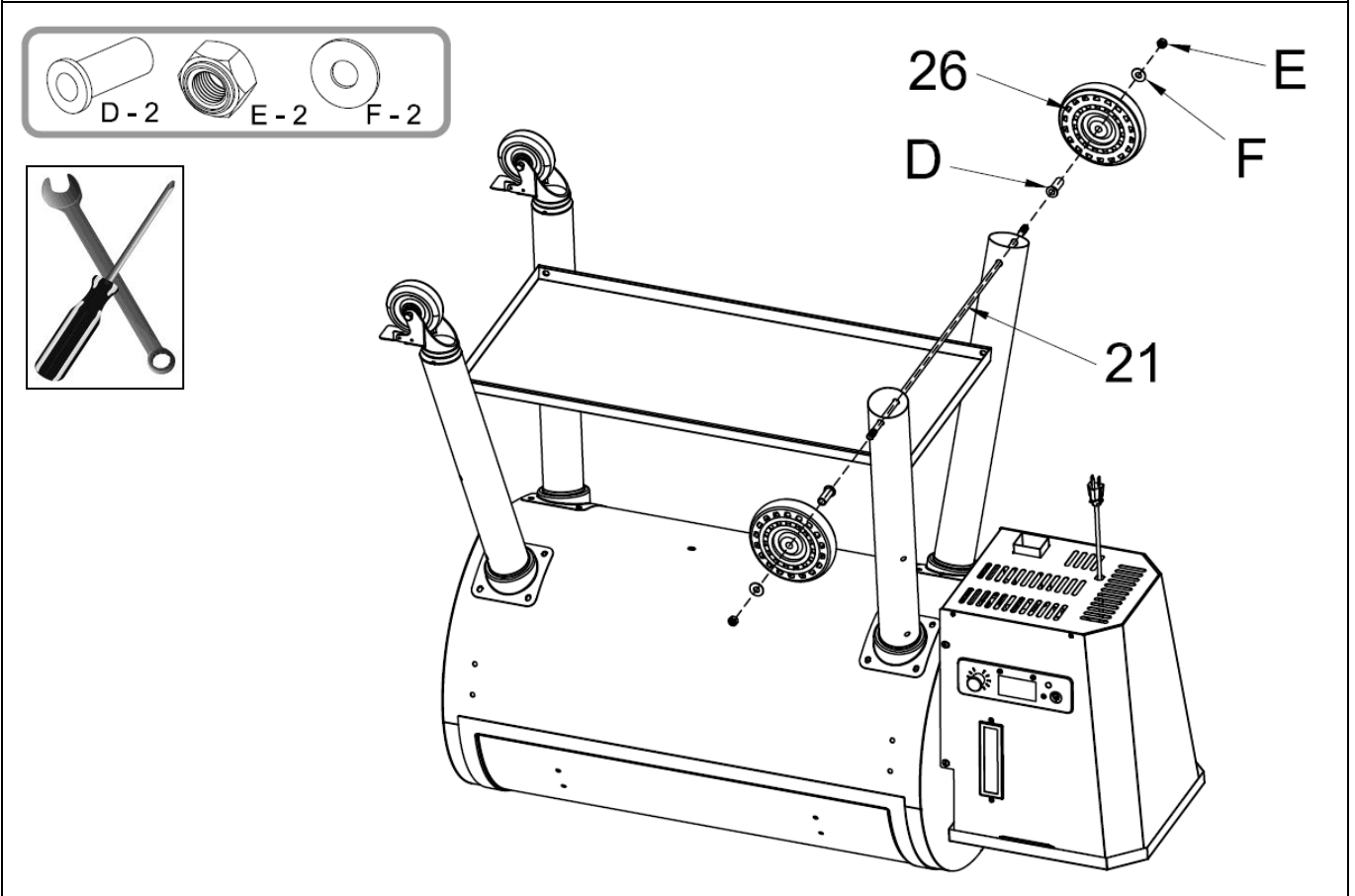

Step 5. Attach the **Cart Front Panel (22)** to the cart using 4 pcs bolt (A).

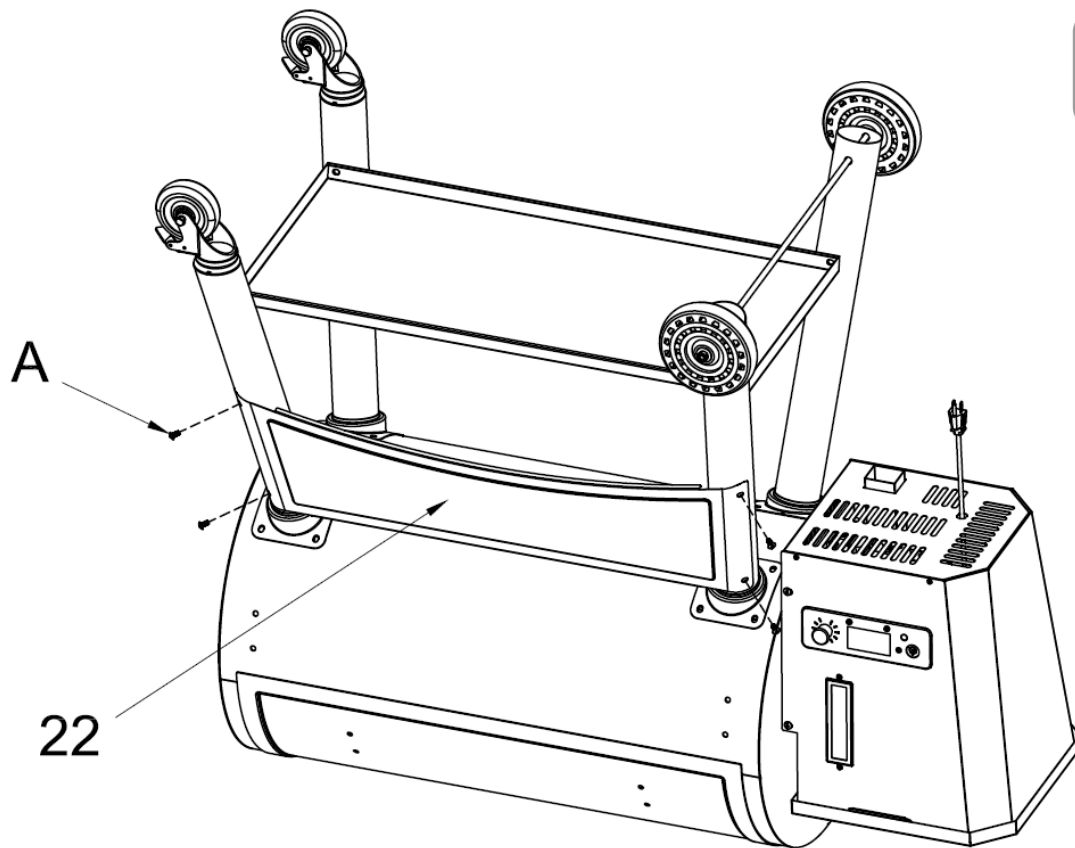

Step 6. Tighten all the bolts and nuts on the cart.

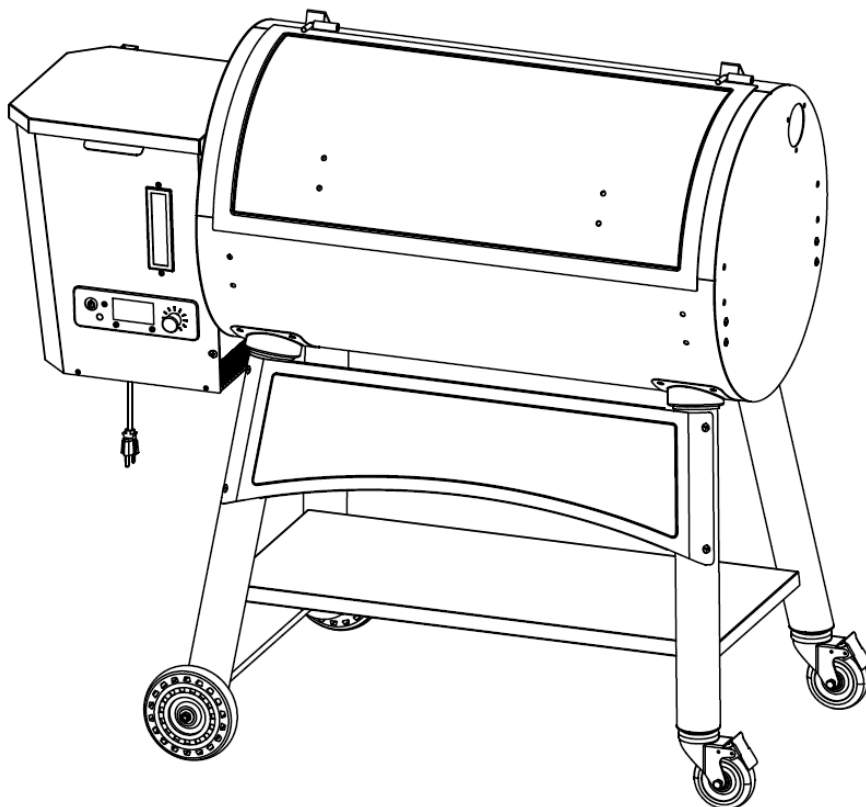

Step 7. Attach the **Lid Handle (4)** and **Lid Handle Heat Shield (3)** to the lid using 2 sets heat insulating washer (G), nut (B) and bolt (H) as shown.

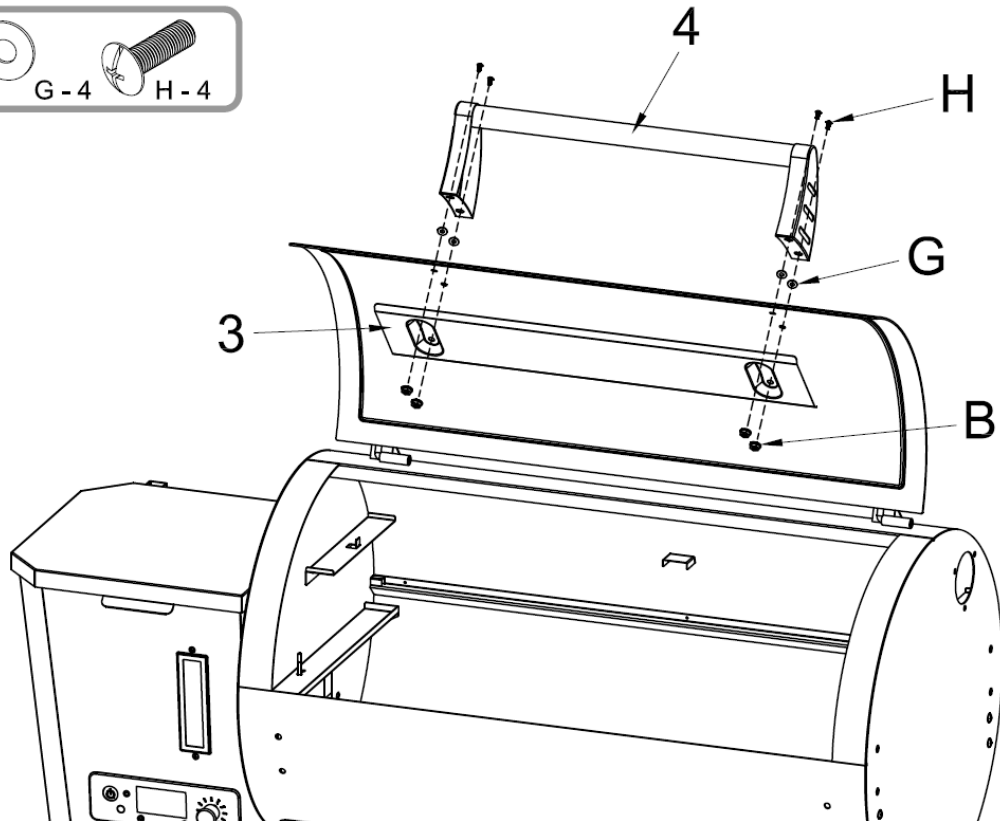
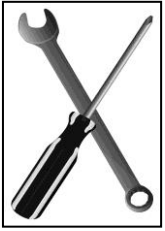

Step 8. Attach the **Grease Drain Assembly (14)** to the grill body using 4 pcs bolt (A) as shown.

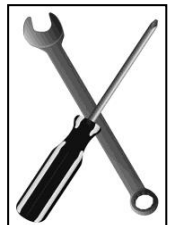
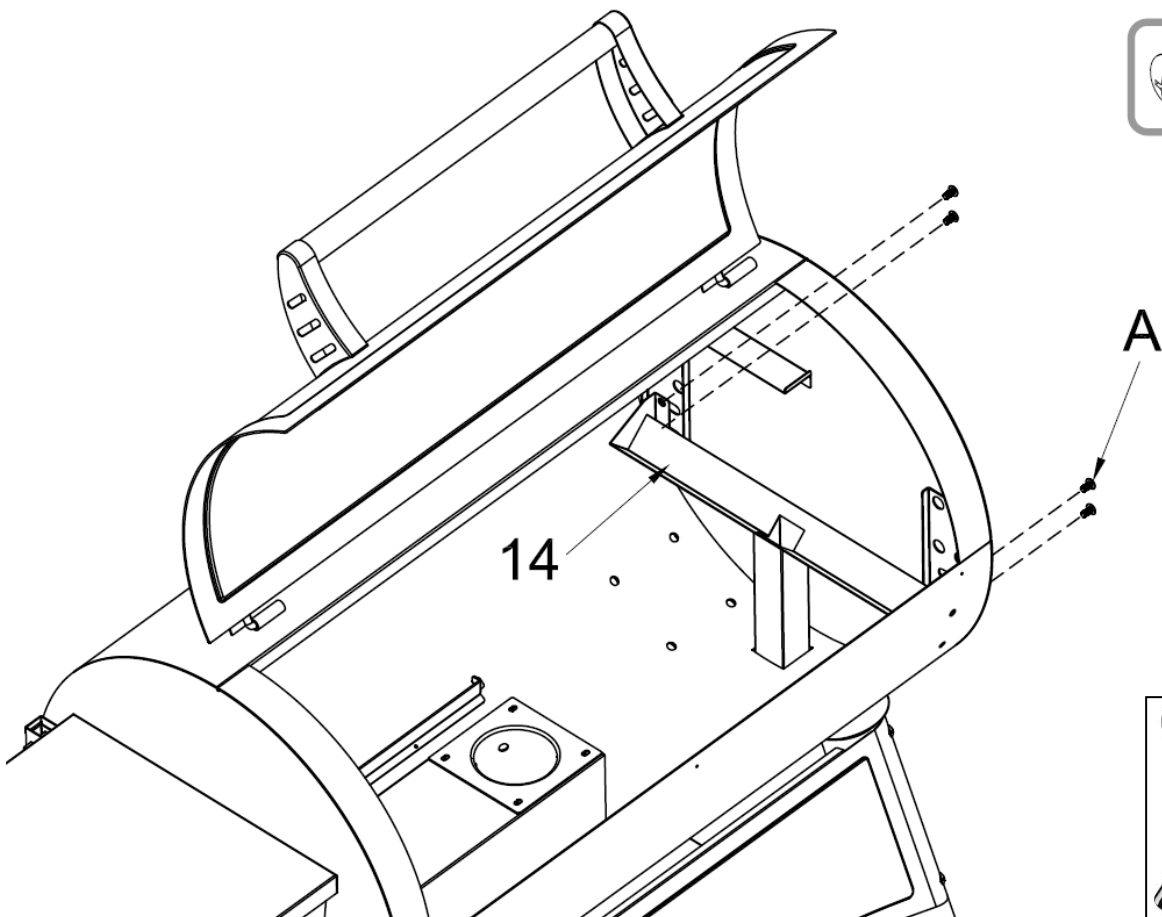

Step 9. Attach the **Smoke Stack Assembly (10)** to the grill body using 3 pcs bolt (A) and nut (B) as shown.

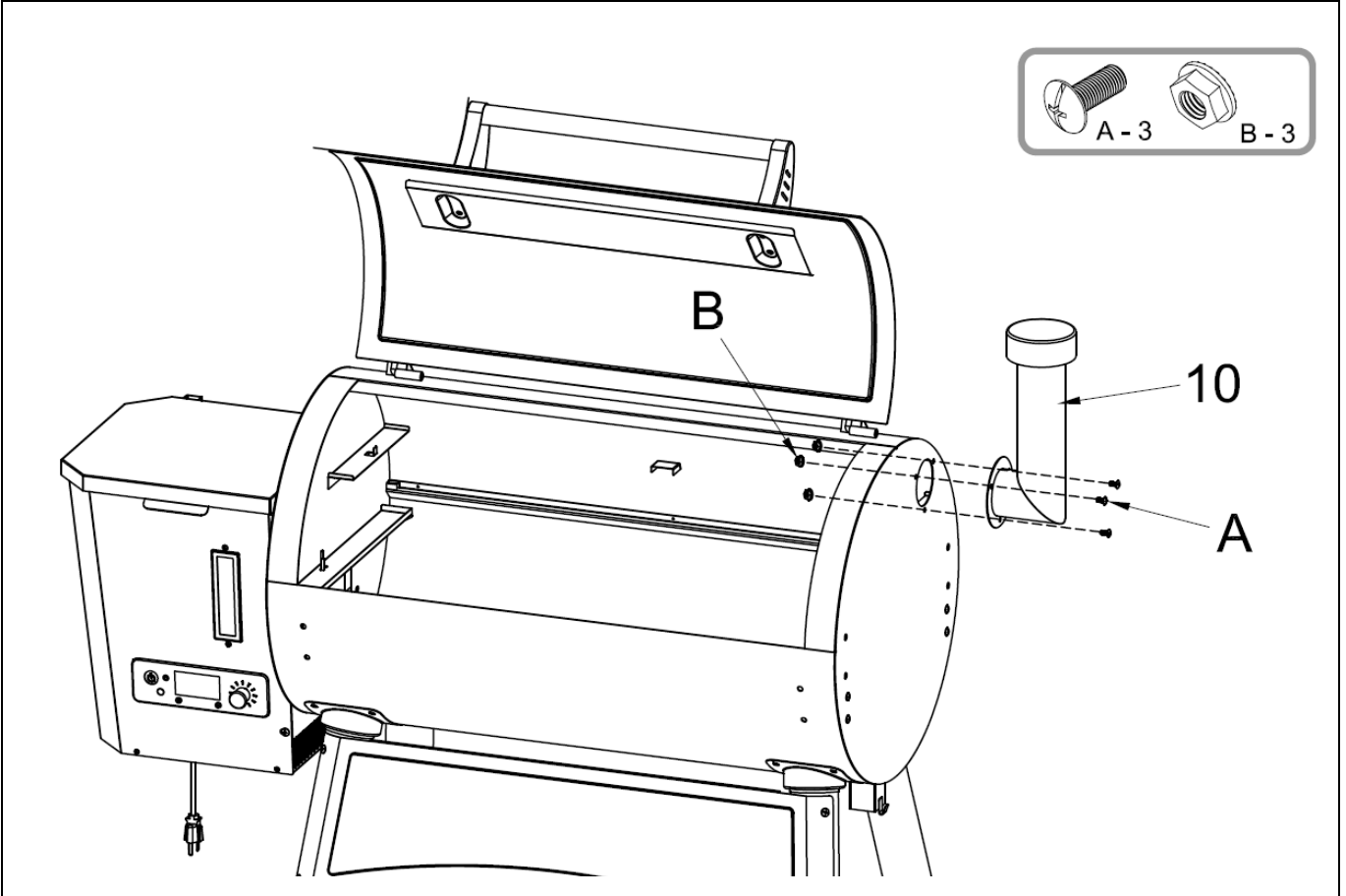

Step 10. Attach the **Side Handle (11)** to the grill body using 4 pcs bolt (A) as shown.

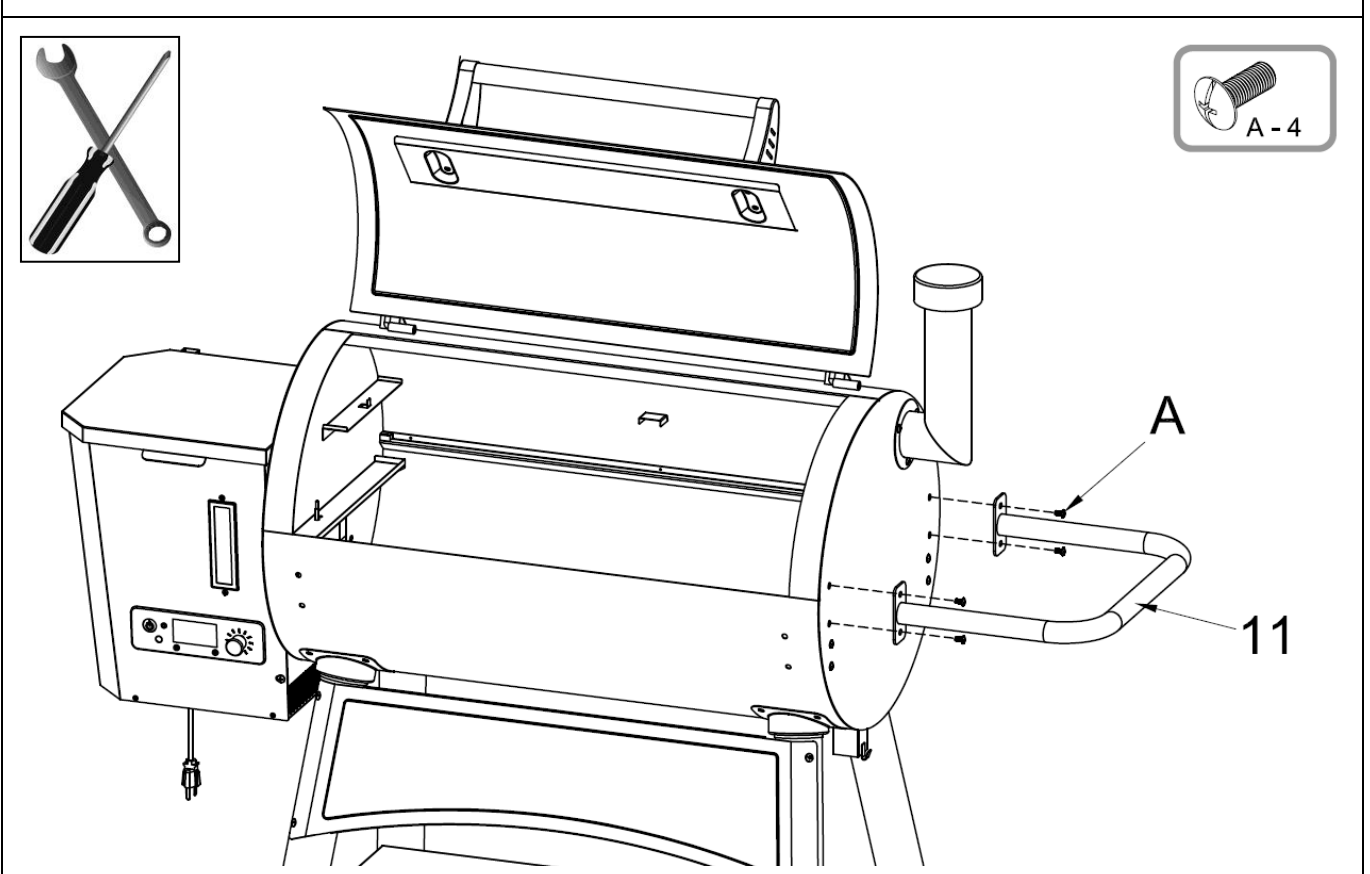

Step 11. Attach the **Front Shelf Brackets (15 & 16)** to the grill body using 4 sets bolt (A) and nut (B) as shown. Please make sure that all the brackets are in right position and direction.

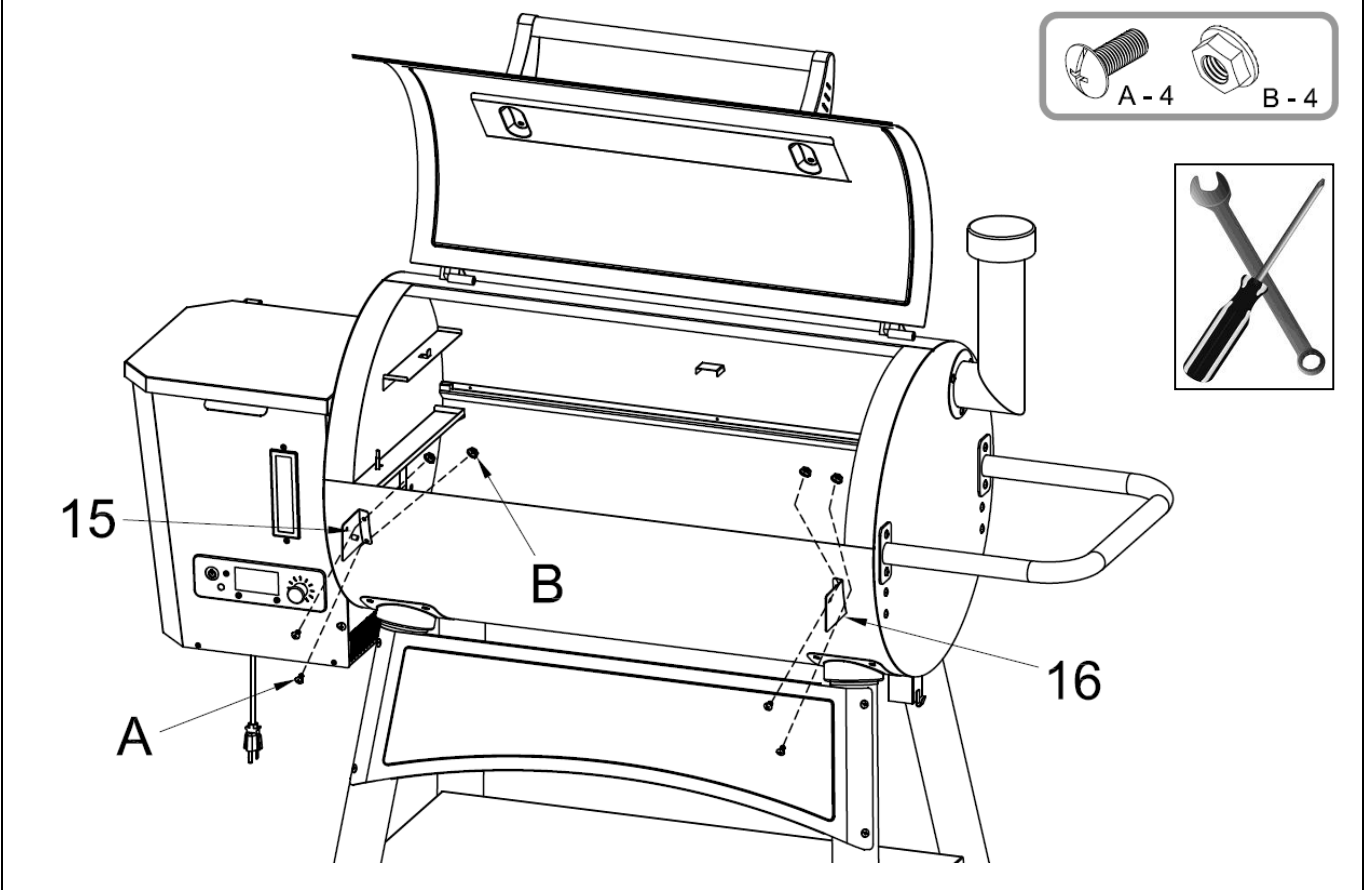

Step 12. Attach the **Front Shelf (17)** to the front shelf brackets using 2 sets bolt (C) and nut (I) as shown.

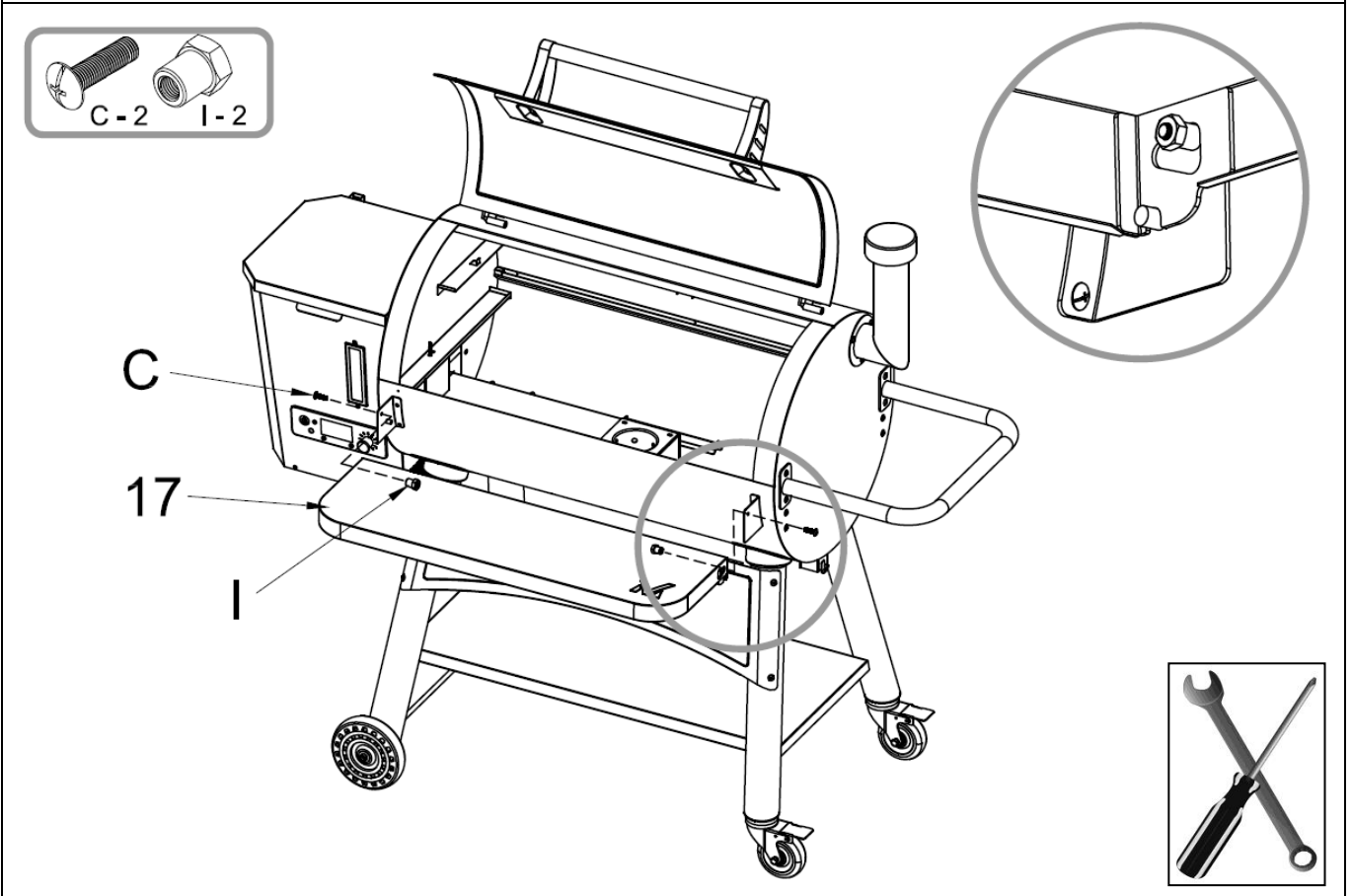

Step 13. Place the **Flame Tamer (6)** on the holding bracket as shown.

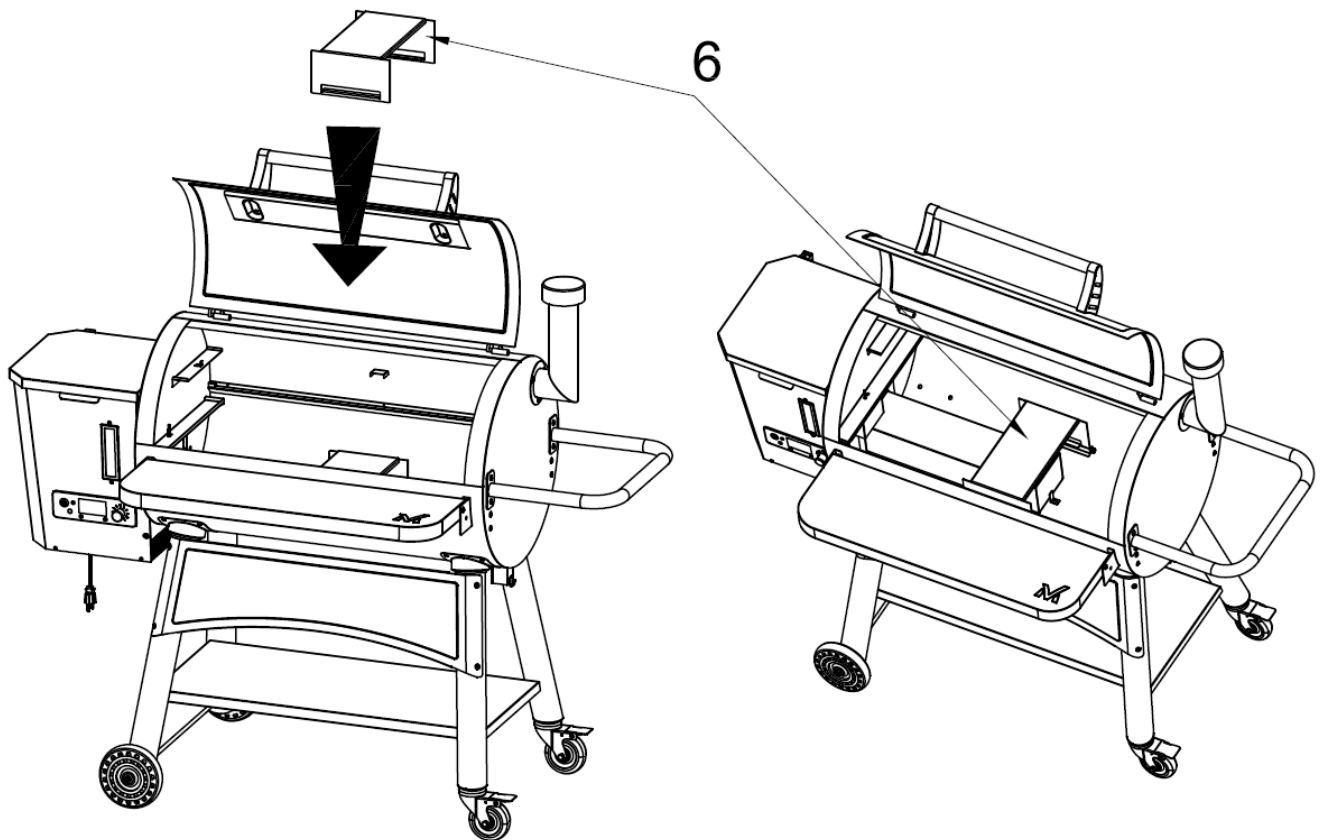

Step 14. Place the **Grease Drip Tray (8)** in the grill body as shown.

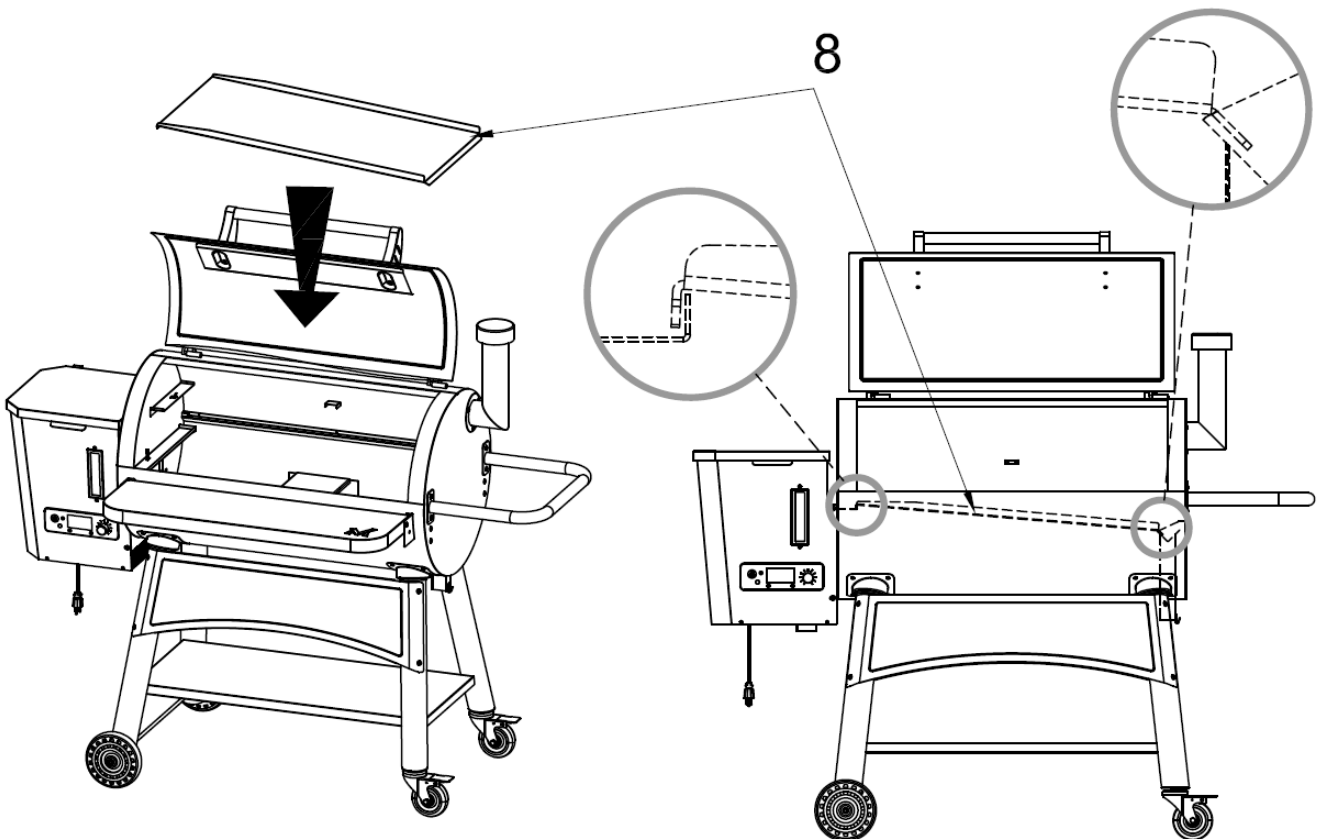

Step 15. Place the **Cooking grate (2)** on the grill body as shown.

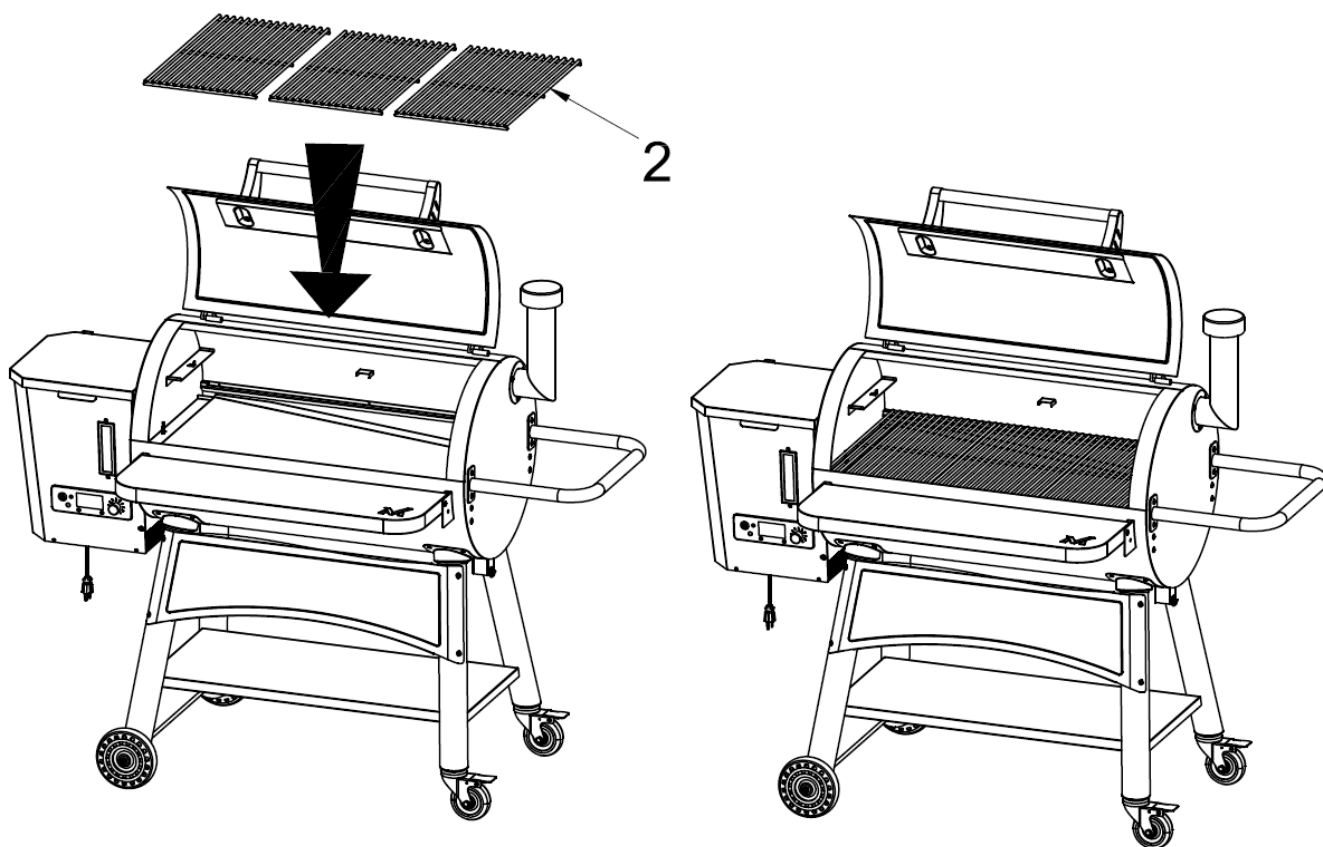

Step 16. Place the **Warming Rack (1)** on the grill body as shown.

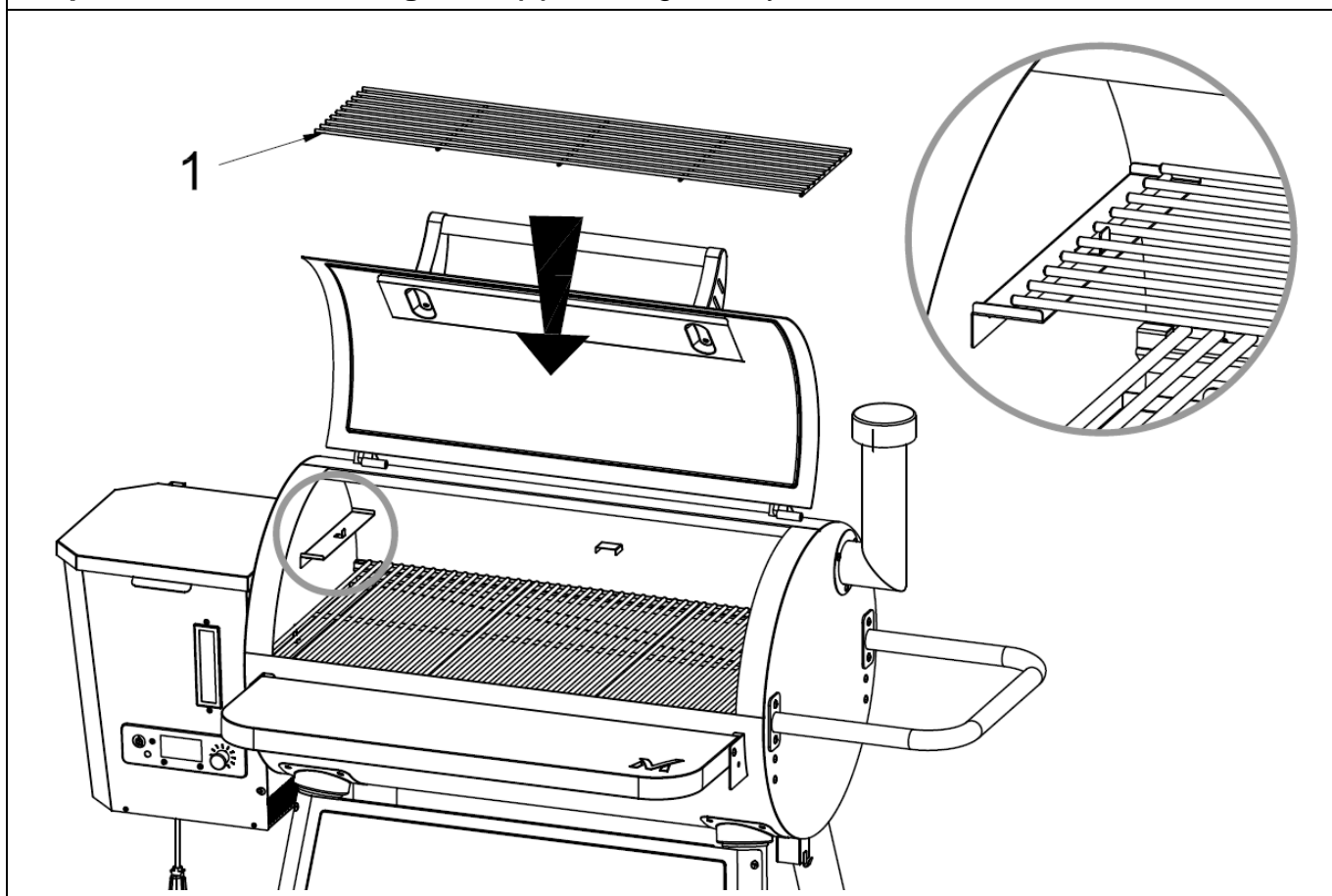

Step 17. Place the **Side Handle Tray (5)**, **Hook (12)** and **Grease Bucket (13)** on the side handle and grill body as shown.

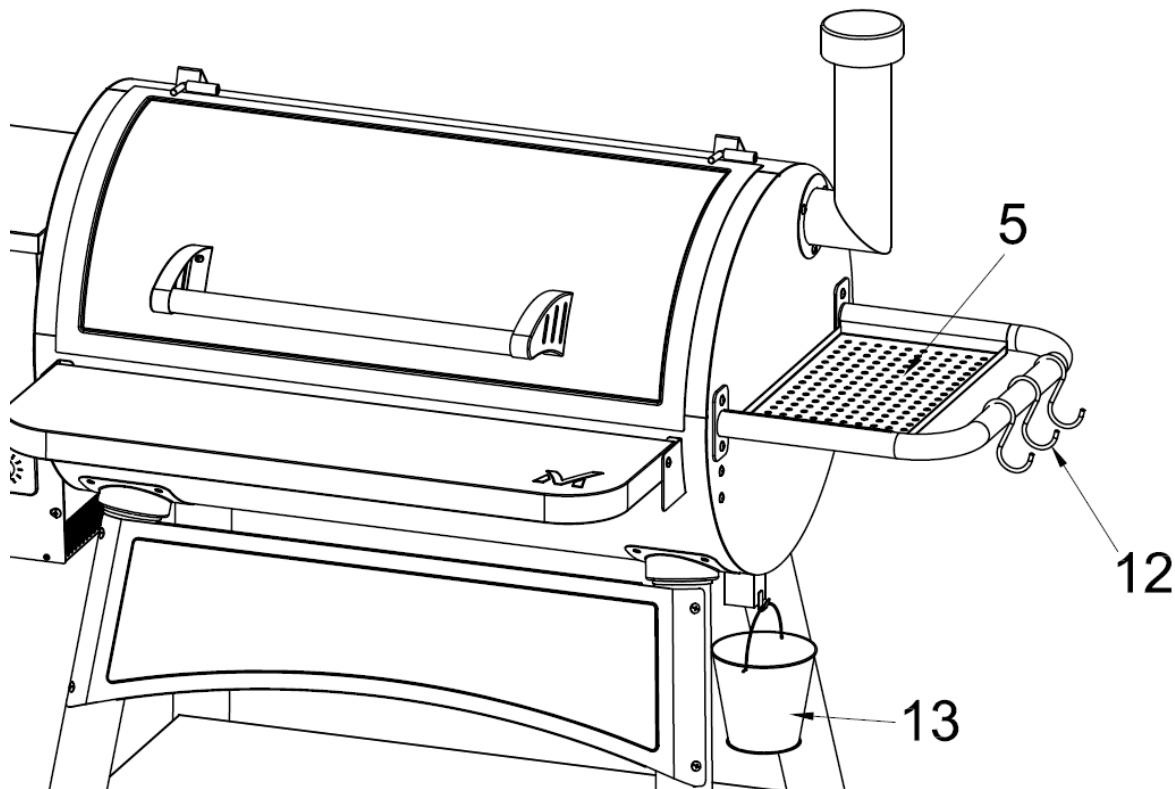

Step 18. Your unit is fully assembled! Make sure to read and follow the Instruction Manual before using this appliance.

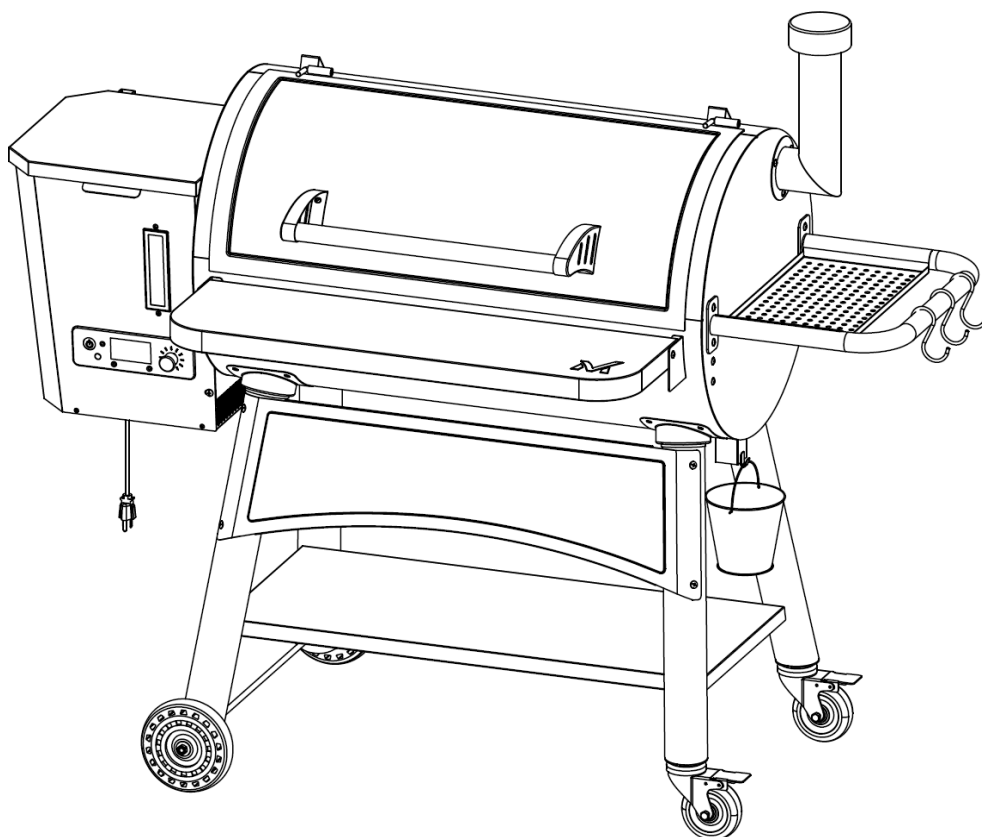

OPERATING INSTRUCTIONS



WARNING



- Only **Dia 6 mm** Pellets can be used.

INITIAL LIGHTING INSTRUCTIONS

1. Read instructions before lighting.
2. Open the lid and take out the cooking grate, grease drip tray and flame tamer.
3. Make sure the control knob is in the **“OFF”** position.
4. Plug the power cord into 120 Volt AC grounded outlet. Press the **POWER BUTTON** “

SUBSEQUENT START-UP

Set the control knob to “**SMOKE**” with the lid open. LCD will show the grill temperature. When the grill temperature reaches 180°F, LCD will show “**SoC**”. At “**SMOKE**” position, auger will keep continuously feeding the pellet for 6 minutes or if grill temperature is above 180°F, auger will stop feeding. Then it will switch to the “**P Set**” mode (detail description of “P Set” in P.27). Around 3 minutes, smoke will come out from the grill once the pellets are ignited. Then turn the control knob to any desired setting with lid closed. We advise to preheat your grill for 15 minutes with lid closed before placing any food in your grill.

If at any times, your grill fails to ignite the pellets in the firepot while cooking or smoking, when abundant pellets are still in the pellet hopper, it is very important to follow below steps. Failure to do, may cause a hazardous “over-firing” of your grill due to excess of unburned pellets in the firepot.

- 1) Press the power button to turn the unit off then plug off the power cord. If the grill is still hot, allow it to completely cool. Open the lid and take out all food, the cooking grate, grease drip tray and flame tamer.
- 2) Remove all unburned wood pellets and ash from inside and around the firepot.
- 3) Before relocating the cooking grate, grease drip tray and flame tamer back into the grill, plug the power cord into an appropriate, grounded electrical outlet and restart your grill. Pellets should fall into the firepot and the hot rod begins to produce heat.
- 4) If above procedures are successful, you will soon see the flames coming out from the firepot. Then set the control knob to “**OFF**” and let your grill cool down. Place the cooking grate, grease drip tray and flame tamer back to their proper positions. Set the control knob to “**SMOKE**” with the lid open. In around 3 minutes, you will notice smoke coming out from your grill. After assuring the pellets are ignited, close the lid and turn the control knob to any cooking desired setting.

“Prime” BUTTON

Press and hold the “**Prime**” button to activate an extra feed of pellets to the firepot. This can be used to add more fuel to the fire before opening the lid, resulting in a quick heat recovery time.

FIRST USE – GRILL BURN-OFF

Once your hopper has been primed and before cooking on your grill for the first time, it is important to complete a grill burn-off. Start the grill and operate at high heat (over 233°C / 450° F) with the lid down for 30 to 40 minutes to burn-off the grill and rid it of any foreign matter.

IF GRILL FAILS TO IGNITE:

1. Turn the control knob to the “**OFF**” position then press the power button to turn the unit off.
2. Wear the protective gloves and make sure all the components are cool to touch. Open the lid, remove the cooking grates, grease drip tray and flame tamer.
3. Remove all unburned pellets and ash from the firepot.
4. When all cleaned, turn the control knob to the “**SMOKE**” position. Check the following:
 - a. Check the hot rod working or not by checking if the hot rod should turn a light red slowly in around 1-2 minutes. DO NOT touch the hot rod.
 - b. Visually confirm the hot rod is protruding approx. 1/2” into the burn pot.
 - c. Visually confirm pellets are dropping in the firepot from auger.

- d. Confirm the draft inducer fan is working by holding your fingers above the firepot to feel the blowing air through the firepot.
5. If one or all of the above are not working, see the trouble shooting section or contact customer service.

SHUTTING OFF YOUR GRILL

When finished cooking, turn the control knob to “**OFF**”. Press the power button to turn the unit off. The grill will begin its automatic cool-down cycle. The auger system will stop feeding pellets, the fire will burn out, and the fan will continue to run 5 minutes. After the fan operates for 5 minutes, the controller and fan will shut off automatically.

CONTROLLER ERROR CODE

Err (RTD Sensor Malfunction)

- When the RTD Sensor is malfunctioned, hot rod, draft inducer fan and auger drive motor will turn off and LCD shows “**Err**”. To reset the unit, you can press the power button to turn the unit off. Wait for 1 minute then switch on the unit again.

ErH (High Temperature Alarm)

- When the grill temperature reached 615°F, hot rod, draft inducer fan and auger drive motor will turn off and LCD will show “**ErH**”. To reset the unit, you can either turn the control knob to off position or press power button to turn the unit off. Wait for 1 minute then switch on the unit again.

ErL (Low Temperature Signal)

- When the hot rod operates for 6 minutes but the grill temperature was below 180°F, hot rod will keep operating for another 6 minutes. If the grill temperature still cannot achieve 180°F, hot rod, draft inducer fan and auger drive motor will turn off and LCD will show “**ErL**”. To reset the unit, you can either turn the control knob to off position or press the power button to turn the unit off. Wait for 1 minute then switch on the unit again.

Whenever either of these alarm conditions occurs you should check to see what caused this condition and fix the problem.

OPERATING TIPS

1. Just like other barbecues, the actual temperature of this grill or the cooking times will be affected by external temperature, humidity, wind conditions, quality of pellets and so on.
2. It is better to shelter your grill from the wind, this will aid in temperature output, heat retention and heat recovery time when opening the lid.
3. Do not open the lid frequently, it will increase your cooking time. But you can open the lid when you want the grill to cool down quickly.
4. Please preheat the grill for 15 minutes before placing food. This make your grill to heat up and quickly return to your desired temperature once your food is placed. Otherwise it will take a longer time to bring both the grill and the food to your desired cooking temperature.
5. Make sure the flame tamer is properly seated on its locating brackets. The long lips of the flame tamer should be pointing down over the firepot. If not seated properly, direct heat and

flame could come out from the firepot and cause a grease fire in your grill.

6. Never move your grill while running.
7. Never put water into the pellet hopper or firepot.
8. Never add pellets to firepot directly. It is dangerous. If you run out of pellets and lose your fire while cooking, let the grill cool down and start again with the INITIAL LIGHTING INSTRUCTIONS.
9. We recommend you cover your grease drip tray with heavy-duty aluminum foil and change it frequently. This is the simplest way to maintain your grease drip tray.

Failure to clean the grease drip tray and grease drain assembly may cause grease fires. If this situation happens, turn the switch OFF to reduce the amount of oxygen in the fire box and keep the lid open until the fire is completely out. AT THE SAME TIME, BE CAREFUL NOT TO BURN YOURSELF. When the grill is completely cool, clean any grease accumulation from the grease drip tray. Replace the foil on the grease drip tray. Then restart the grill and resume cooking.

HOW TO USE THE MEAT PROBE

Plug the meat probe into the pellet control panel as shown. The temperature will show on the LCD immediately.

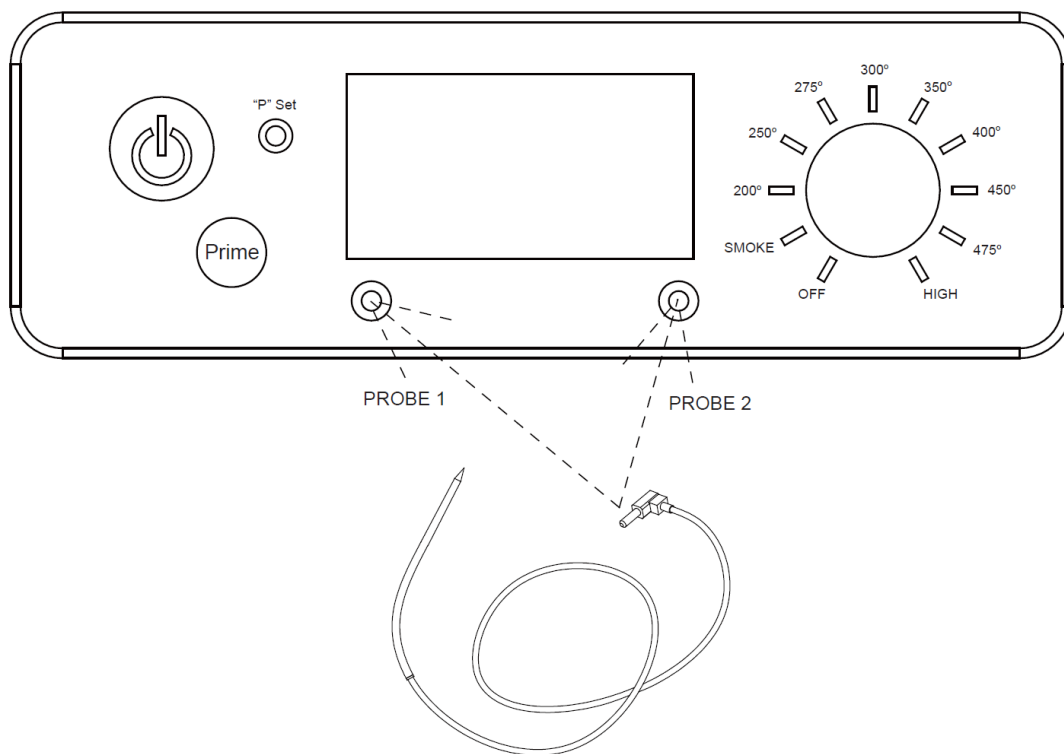

MEAT TEMPERATURE RECOMMENDATIONS

Range	Beef	Lamb	Pork	Poultry
Well	170°F	160°F	170°F	170°F
Medium	160°F	155°F	160°F	170°F
Medium Rare	145°F	145°F		170°F
Rare	135°F			170°F

USING WOOD PELLET FUEL

Wood pellets appear no thicker than the eraser on the end of a pencil. People who see them for the first time think they look like rabbit food; however, there is nothing small about the heat or flavor in barbecue wood pellet fuel. These clean-burning barbecue wood pellets generate about 8200 BTU's per pound with very little ash, a low moisture content (5-7%), and are carbon neutral. Barbecue wood pellets are produced by pure raw material (sawdust) being pulverized with a hammer-mill, and the material is pushed through a die with pressure. As the pellet is forced through the die, it is cut, cooled, screened, vacuumed, and then bagged for consumer use. Check with your local dealer for flavors available in your area.

UNDERSTANDING THE “P” SETTING

The benefit of the “P” Set button is that it allows the cook to have fine tuned control of their grill to compensate for ambient temperature, humidity, wind, environmental changes, pellet fuel type and quality.

When the recessed “P” Set button is pushed, the “P” SET displayed on the LCD screen will flash and change to the next value (upward). Once P7 is reached, it will restart at P0. There are eight “P” setting, ranging from P0 to P7. The recessed “P” Set button can be pushed using a thin-tipped object, such as a pen tip, toothpick, kabob skewer or screwdriver.

IMPORTANT: Do not push the “P” Set button too hard, as this may cause damage. Only a light push is needed.

“P” Set	Auger On (S)	Auger Off (S)
P0	15	55
P1	15	70
P2	15	85
P3	15	100
P4	15	115
P5	15	130
P6	15	140
P7	15	150

USING THE “P” SETTING IN SMOKE MODE

Anytime the control knob is set to the **SMOKE** setting, such as the start-up of the unit, the auger will run on a manual mode of cooking versus using one of the preset temperatures on the control knob.

First, the auger will continuously turn and feed pellets for six minutes or reach 180°F. After six minutes or reach 180°F, the auger begins to run a feed cycle based on the “P” setting selected on the pellet control panel. The default setting is P4.

MAINTENANCE & CLEANING INSTRUCTIONS



CAUTION



- Make sure your grill is OFF and cold completely before performing any maintenance and cleaning.

STEEL SURFACES

There are different stainless steel cleaners available. Always use the mildest one for cleaning first and scrubbing in the direction of the grain. To touch up noticeable scratches in the stainless steel, sand very lightly with dry 100 grit emery paper in the direction of the grain. Specks of grease can gather on the surfaces of the stainless steel and bake on to the surface, giving the appearance of rust. To remove, use a soft abrasive pad in conjunction with a stainless steel cleaner.

GREASE

With long-term use, it caused the accumulation of grease on the flue lining and the grease drip tray. Always be sure this grease catching area is clean and free of debris. You should check and clean these areas periodically to reduce the risk of fire. The flue exhaust should be inspected at least twice a year to determine if grease buildup has resulted.

The grease bucket should be emptied, wiped down periodically, then washed with a mild detergent and warm water solution. Check the grease bucket frequently. Don't allow excess grease to accumulate and overflow the grease bucket.

The grease bucket and the grease drip tray should be inspected at least twice a year for signs of grease buildup.

It is easier to clean of accumulated grease when the grill is still warm -- not hot. **Be Careful Not To Burn Yourself.** Gloves are recommended.

COOKING GRATE

We recommend using a long-handled cleaning brush to give the porcelain-coated cooking grate a quick brushing when you finish the barbecue. It takes only a minute and it will be ready the next time you want to use the grill.

Ash

Clean the ash from the interior of the grill periodically, otherwise excess ash in the firepot may cause your fire to go out, especially in the SMOKE setting.

A shop vac is an excellent tool to handle the ash. (**WARNING:** Make sure you grill is cold when you want to clean the ash from the grill.)

A vacuum cleaner is the best way to clean the pellet ash from the firepot but this must be done with extreme care to avoid fire risk. Again, removing the pellet ash from the firepot should be done only while your grill is cold.

HOPPER ASSEMBLY

The hopper includes a clean-out feature to allow for ease of cleaning and change out of pellet fuel flavors. Before empty the hopper, place a clean and empty pail under the pellet extractor tube (part number 9d) then pull the pellet extractor handle (part number 9j) outwards to release the pellets from hopper.

NOTE: Use a long handled brush or shop-vac to remove excess pellets, sawdust and debris for a complete clean-out through the hopper screen.

Check and clean off any debris from the fan air intake vent, found on the bottom of the hopper. Once the control panel is removed, carefully wipe off any grease build-up directly on the fan blades. This ensures airflow is sufficient to the feed system.

CLEANING FREQUENCY TIME TABLE (NORMAL USE)

ITEM	CLEANING FREQUENCY	CLEANING METHOD
Inside bottom of grill body	Every 5-6 grill sessions	Scoop out, shop-vac excess debris
Pellet firepot	Every 2-3 grill sessions	Scoop out, shop-vac excess debris
Cooking grates	After each grill session	Burn off excess, brass wire brush
Flame tamer	Every 5-6 grill sessions	Scrape with slider, do not wash clean
Grease bucket	After each grill session	Scrub pad & soapy water
Feeder assembly	When pellet is empty	Allow auger to push out sawdust, leaving hopper empty
Hopper electric components	Once a year	Dust out interior, wipe fan blades with soapy water
Air intake vent	Every 5-6 grill sessions	Dust, scrub pad & soapy water
RTD sensor	Every 2-3 grill sessions	Scrub pad & soapy water

THE PELLET CONTROL PANEL REPLACEMENT

1. Disassemble the bolts on the hopper bottom panel.
2. Cut off the cable tie for internal wires.
3. Disconnect all the wire couplings of fan motor, auger drive motor, hot rod, RTD sensor and power cord (Detail wire pairing is as shown in P.30 DIGITAL THERMOSTAT CONTROL WIRING DIAGRAM).
4. Take out the control panel from the hopper panel.
5. Replace a new pellet control panel. Connect all the wire couplings to the related position (refer P.30 DIGITAL THERMOSTAT CONTROL WIRING DIAGRAM). Tie up the wires with cable tip then assemble all the parts with their original bolts.

DIGITAL THERMOSTAT CONTROL WIRING DIAGRAM

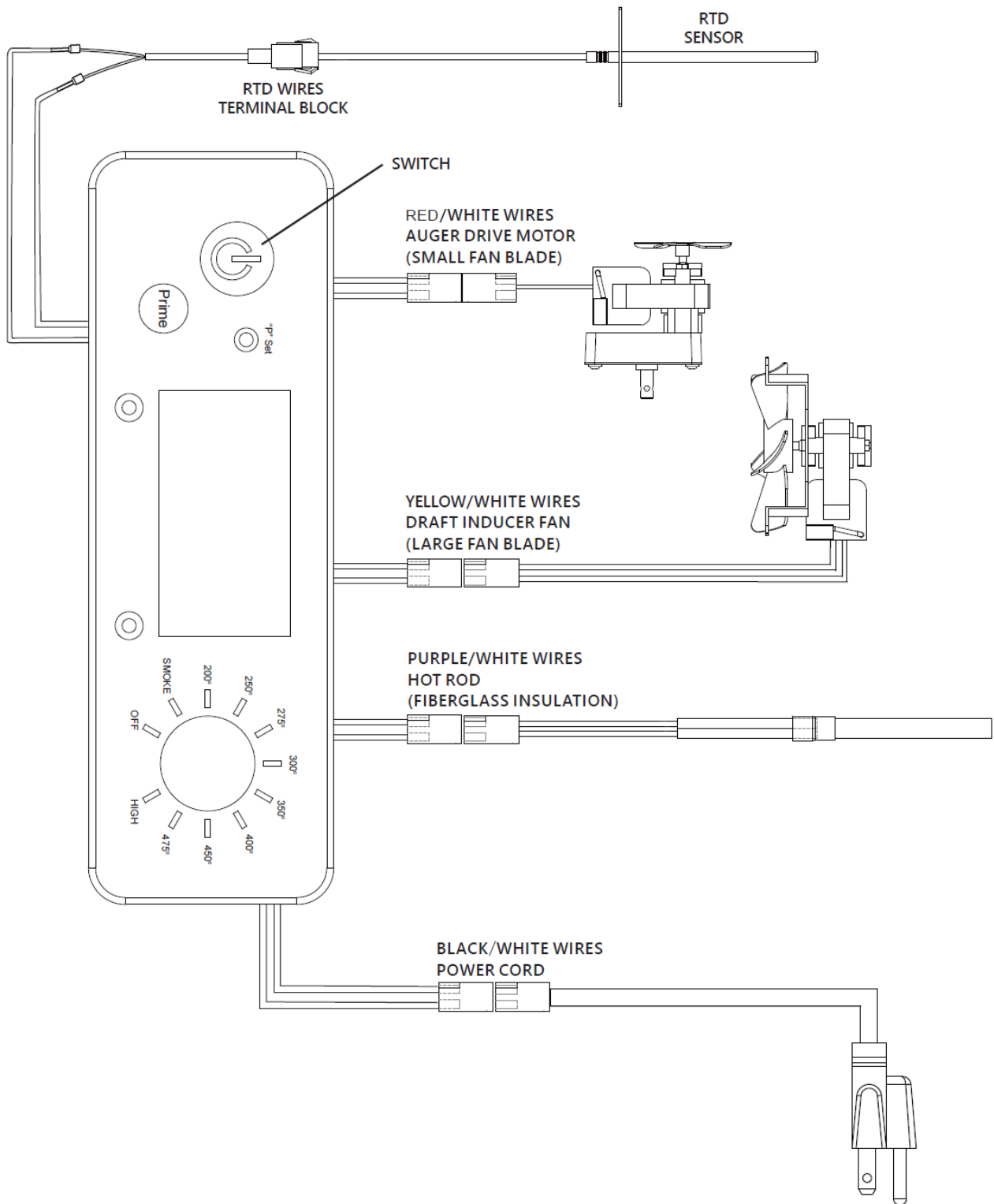

QUALITY
. YOU DESERVE .

100% GUARANTEED

We are so confident you will be delighted with your Member's Mark purchase that we promise to refund or replace any item you find unsatisfactory. We aim to delight all our members and would love to hear about your discoveries! Call us at : **1-888-301-0332** (toll-free), 8am - 5pm CST Monday - Friday.

TROUBLE SHOOTING

Problem:	Possible Causes:	Corrective Actions:
Grill does not work properly	<ol style="list-style-type: none"> 1. Power 2. Fuse 3. Hot Rod 4. Control Panel 5. Auger Drive Motor 	<ol style="list-style-type: none"> 1. Make sure the power cord is plugged in. Verify there is power at the electrical outlet. 2. Remove the control, check the fuse on back. Replace the fuse if blown out. 3. If both of the Draft Inducer Fan and the Auger Driver Motor are operating, the Hot Rod needs to be replaced. If one or both are not operating, please contact us. 4. Remove the Control Panel, check the wires and connections. 5. Locate the small fan blade on the back of the auger drive motor, turn unit on, if the fan does not turn, it indicates the Auger Drive Motor need to be replaced.
Fire goes out	Too much ash	Refer to the section of "Maintenance and Cleaning instructions" at P.28-29 to clean the ash.
How to start	SMOKE setting	Start your grill on SMOKE setting with the lid open, after 3 minutes, close the lid and turn to any desired temperature setting.
Unexpected grill temperature is displayed	External Factor	Grill temperature is influenced by environmental factors such as high temperature, wind and direct sun. Place unit in shaded area. Open the lid to reduce inside temperature.
Excess or discolored smoke	Pellets	Replace moist pellets with fresh dry pellets.

If any symptom is not listed, please contact our customer service at 1-888-837-1380.

LIMITED WARRANTY

1. Manufacturer warrants this Product to be free from defects in workmanship and materials for a period of Ninety (90) days from the date of purchase, PROVIDED claims are submitted, in writing, with proof of purchase.
2. If any part of this item fails because of a manufacturing defect within the Limited Warranty Period, Manufacturer offers to replace such part(s) provided that such parts have not been improperly repaired, altered, or tampered with or subject to misuse, abuse or exposed to corrosive conditions. This Limited Warranty is, however, subject to certain limitations, exclusions, time limits and exceptions (Hereinafter "Conditions") as listed below. Read these Conditions carefully.
3. This Limited Warranty shall be limited to the replacement or repair of any part(s) which Manufacturer determines, after reasonable examination, to have been defective at the time of manufacturing and manufacturer's obligation(s) shall be limited to replacement, if any, of defective part(s) which shall be shipped at Original Purchaser's expense to Original Purchaser's designated shipping address.
4. This Limited Warranty is given to and covers the **ORIGINAL PURCHASER ONLY** and such coverage terminates Ninety (90) days from the date of purchase.
5. **DAMAGE LIMITATION WARNING:** IN NO EVENT SHALL MANUFACTURER BE LIABLE FOR ANY INCIDENTAL OR CONSEQUENTIAL DAMAGES, INCLUDING (BUT NOT LIMITED TO) LOSS OF USE OF THE PRODUCT, LOSS OF TIME, LOSS OF FOOD, INCONVENIENCE, EXPENSES FOR TRAVEL, TRANSPORTATION LODGING EXPENSES, LOSS BY DAMAGE TO PERSONAL PROPERTY OR LOSS OF INCOME, PROFITS OR REVENUE.
6. **MANUFACTURER'S OBLIGATION:** Manufacturer's liability shall be limited to the delivery of a good, merchantable Product and, if necessary, the repair or replacement, at manufacturer's option, of any defective part or unit.
7. **TRANSFER LIMITATIONS:** This Limited Warranty is not assignable or transferable. It covers only the original purchaser.
8. **RESERVED RIGHT TO CHANGE:** Manufacturer reserves the right to make changes or improvements to products it produces in the future without imposing on itself any obligations to install the same improvements in the products it has previously manufactured.
9. This Limited Warranty gives the Original Purchaser specific legal rights but there may be other rights which vary by jurisdiction.
10. This warranty does not cover the following items:
 - Chips or scratches on porcelain or painted surfaces.
 - Rust or corrosion is not deemed a manufacturing or materials defect.
 - Discoloration or loss of paint due to handling during assembly, heat or cleaning products. Paint may require touch up.
 - Stainless steel discoloration or corrosion.
 - Consumables such as batteries.

IF CUSTOMER SERVICE BECOME NECESSARY:

1. The Original Purchaser is responsible for shipping and handling charges of the returned item(s) and replacement parts, if any.
2. All parts to be replaced will need to be shipped before replacement items will be sent.
3. Follow the Customer Service Representative's instructions exactly. If a return is necessary, it must be packed carefully and shipped prepaid.

**Should you encounter any problem,
CALL US FIRST.
Do not return product to the store.
WE CAN HELP.**



For assistance, contact customer service at customerservice@rankam.com
or at **1-888-837-1380**, Mon to Fri, 8:00am – 5:00pm Pacific Standard time

Manufacturer information

Rankam (China) Manufacturing Company Limited
Address: 18/F, New Lee Wah Centre, 88 Tokwawan Road, Kowloon, Hong Kong.