

This Owner's Manual is provided and hosted by [Appliance Factory Parts](http://www.appliancefactoryparts.com).



Permasteel PS-206-Pepsi Owner's Manual

[Shop genuine replacement parts for Permasteel
PS-206-Pepsi](#)



[Find Your Permasteel Other Parts - Select From 22 Models](#)

----- Manual continues below -----

CARE AND MAINTENANCE:

Before using, clean the cooler completely with a soft dry towel, take off the lid and put drinks and ice into the cooler.
Drain away all the water in the cooler, clean and dry the cooler completely with a soft towel after use.
Indoor storage preferred while not in use.

PEPSI is a trademark of PepsiCo, Inc. Used under license ©2014 PepsiCo, Inc.



Owner's Manual
CONTACT US

Questions? Need parts?
We are here to help!

Permasteel Customer Service

Tel: 909-287-0730

Fax: 909-287-0733

Email: service@permasteel.net

Monday-Friday

8:00am-5:00pm (Pacific Standard Time)



80QT PATIO COOLER
MODEL# PS-206-PEPSI

IMPORTANT

Please take time to read these instructions thoroughly and follow each step carefully for safe and easy operation. Keep this manual for future reference.

PARTS LIST

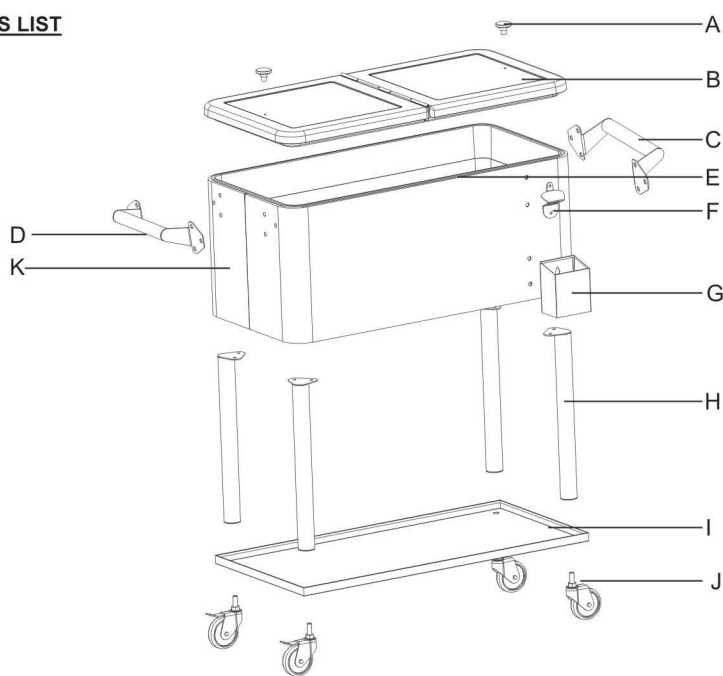

Item	Description	Qty
A	Lid handle	2
B	Lid	1
C	Short Body handle	1
D	Short Body handle	1
E	Body	1
F	Bottle Opener	1
G	Bottle Cap Catcher	1
H	Leg	4
I	Bottom Shelf	1
J	Wheels (2 With Brake, 2 Without Brake)	4
K	Water Drain Plug Assembly	1
AA	M6X16 Hex Bolt	8
BB	M6X16 Hex Socket Bolt	14
CC	M6X16 Shoulder Bolt	2
DD	M5X35 Screw	2

Fig. 1

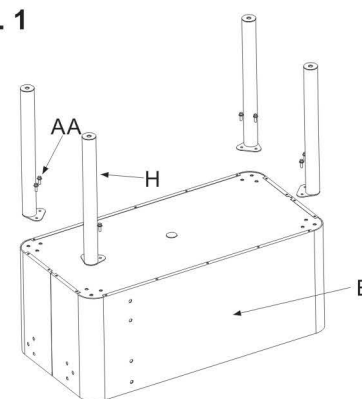

Step 1:
Connect 4 legs (H) and body (E) with bolts (AA).

Fig. 2

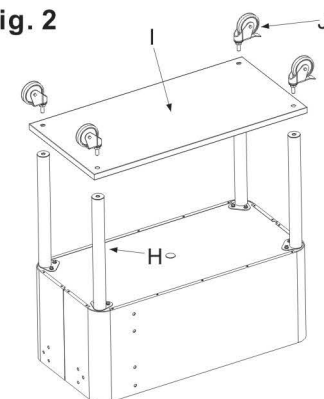

Step 2:
Connect 4 legs (H) and bottom shelf (I), then connect 4 wheels (J) and legs (H). (Do not fully tighten bolts yet).

Fig. 3

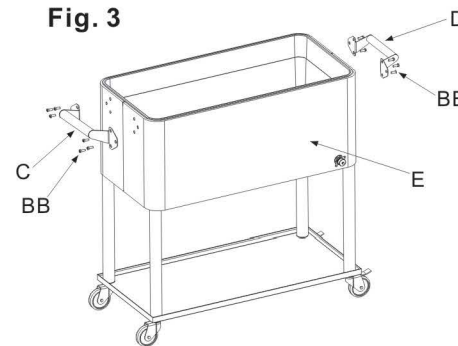

Step 3:
Connect 2 body handles (C & D) and body (E) with bolts (BB) (pre assembled on E), then fully tighten.

Fig. 4

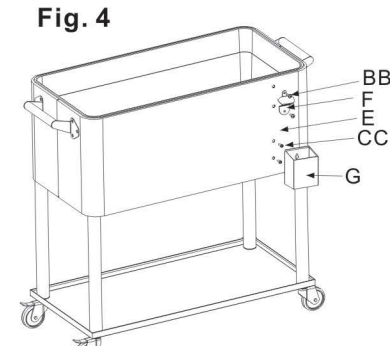

Step 4:
Connect bottle opener (F) and body (E) with bolt (BB) and fully tighten. Attach bottle cap catcher (G) with bolt (CC) to pre-installed on body (E).

Fig. 5

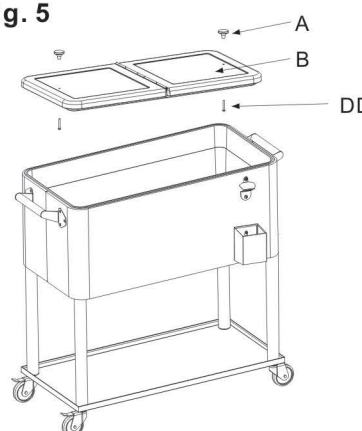

Step 5:
Connect lid handle (A) and lid (B) with screws (DD) (pre-assemble on B) and fully tighten. Your assembly is now complete.