

This Owner's Manual is provided and hosted by [Appliance Factory Parts](#).



Landmann 560202 Owner's Manual

[Shop genuine replacement parts for Landmann 560202](#)



[Find Your Landmann Grill Parts - Select From 200 Models](#)

----- Manual continues below -----



LANDMANN
vista

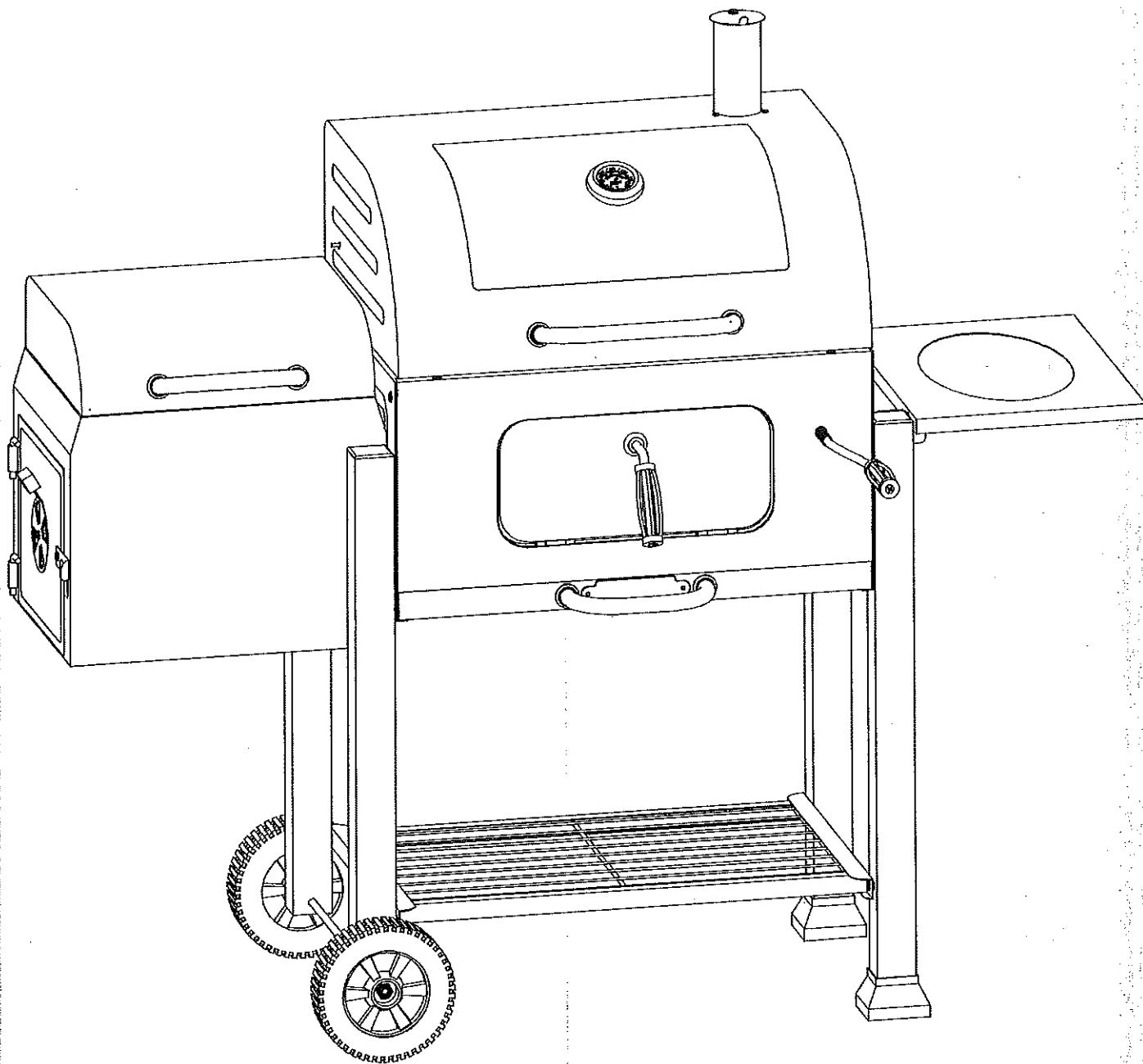

**Smoky Mountain Series®
Vista Charcoal Grill with
Offset Smoker Firebox**

**Assembly and Operating
Instructions for Model:
560202**



**PLEASE READ ALL RULES FOR SAFE
OPERATION AND FOOD SAFETY BEFORE USING.**

VER. 2, 6/30/2016

READ FIRST! RULES FOR VISTA CHARCOAL GRILL SAFE OPERATION.

- THE GRILL IS FOR OUTDOOR USE ONLY!
- KEEP THE GRILL A MINIMUM OF 10 FT. AWAY FROM BUILDINGS, STRUCTURES, ANY FLAMMABLE ITEMS AND VEHICLES DURING USE.
- NEVER USE THE GRILL UNDER COVERED PORCHES, AWNINGS, LOW HANGING TREE BRANCHES, TRELLIS, OR OVERHANGS OF ANY KIND.
- NEVER USE INSIDE ENCLOSED AREAS SUCH PATIOS, GARAGES, ENCLOSED ROOMS, BUILDINGS OR TENTS.
- ALWAYS USE THE GRILL ON A HARD, STABLE AND LEVEL SURFACE.
- THE GRILL IS FOR ADULT USE ONLY.
- WARNING! NEVER USE GASOLINE, ALCOHOL OR VOLATILE FLUIDS TO START OR RESTART FIRES. USE CHARCOAL LIGHTER FLUID ONLY TO START CHARCOAL. READ AND FOLLOW CHARCOAL LIGHTER FLUID MANUFACTURER INSTRUCTIONS CLOSELY.
- WARNING! DO NOT OPERATE GRILL WITHOUT ASH TRAY IN PLACE, DO NOT OPEN ASH TRAY DURING USE.
- DO NOT STORE LIGHTER FLUID OR OTHER FLAMMABLE LIQUIDS OR MATERIALS ON THE BOTTOM SHELF.
- KEEP CHILDREN AND PETS AWAY WHILE THE GRILL IS BEING USED.
- MITTENS OR GLOVES WILL BE NEEDED TO OPEN THE LID AND DOORS AS SURFACES WILL BE HOT.
- MOST SURFACES OF THIS GRILL BECOME HOT, USE CAUTION.
- DO NOT MOVE THE GRILL WHILE IT IS BEING USED.
- DO NOT LEAVE UNATTENDED AT ANY TIME WHILE IN USE.
- DO NOT USE IN WINDY CONDITIONS.
- USE CAUTION WHEN OPENING THE LID AS HOT STEAM OR A FLARE UP COULD CAUSE BURNS.
- BEFORE EACH USE, MAKE SURE THE GRILL IS IN GOOD WORKING CONDITION.
- FOR LONGER PRODUCT LIFE, KEEP THE CHARCOAL FIRES TO A RESPECTABLE SIZE, DO NOT OVERLOAD.
- DO NOT ALLOW CHARCOAL TO COME IN CONTACT WITH THE GRILL SIDES, KEEP CHARCOAL INSIDE CHARCOAL PANS.
- ALLOWING THE CHARCOAL TO CONTACT THE GRILL SIDES WILL GREATLY REDUCE THE LIFE OF THE METAL AND THE FINISH.
- DO NOT ALTER THE GRILL IN ANY WAY.
- DO NOT USE THE GRILL UNTIL IT IS COMPLETELY ASSEMBLED WITH ALL PARTS SECURELY TIGHTENED.
- THE SIDE SHELF CAN HOLD 10 LBS. SAFELY, DO NOT PUT MORE THAN 10 LBS. ON THE SIDE SHELF.
- DO NOT LEAN OR PUSH DOWN ON THE SIDE SHELVES.
- USE CAUTION AFTER THE FIRE HAS BEEN EXTINGUISHED- SURFACES WILL REMAIN HOT FOR SOME TIME.
- BE SURE ALL COALS ARE COLD BEFORE DISPOSING.
- DISPOSE OF COALS PROPERLY.
- THE GRILL MUST BE COMPLETELY COOLED OFF AND ALL EMBERS MUST BE EXTINGUISHED BEFORE ANY COVER CAN BE USED.

FOOD SAFETY

- RAW MEAT AND POULTRY HAS TO BE KEPT SEPARATE FROM READY TO EAT FOOD.
- USE CLEAN PLATTERS AND UTENSILS FOR HANDLING COOKED FOODS.
- COOK POULTRY AND MEATS THOROUGHLY TO KILL BACTERIA.
- USE INSTANT-READ THERMOMETER TO ENSURE PROPER INTERNAL FOOD TEMPERATURES.
- KEEP PREPARED FOOD AND LEFTOVERS REFRIGERATED.
- WASH HANDS, UTENSILS AND SURFACES WITH SOAP AND HOT WATER PRIOR TO AND AFTER HANDLING RAW MEAT AND POULTRY.



WARNING!
FUELS USED IN WOOD OR CHARCOAL BURNING APPLIANCES, AND THE PRODUCTS OF COMBUSTION OF SUCH FUELS, CONTAIN CHEMICALS KNOWN TO THE STATE OF CALIFORNIA TO CAUSE CANCER AND BIRTH DEFECTS OR OTHER REPRODUCTIVE HARM.

PARTS LIST

When unpacking the grill from the carton, make sure you find and become familiar with all the parts listed below. Use caution as some parts may have sharp edges.

GRILL PARTS

	QTY
A. LID	1
B. BACK PANEL	1
C2. LEFT PANEL	1
DD. RIGHT PANEL	1
EE. FRONT PANEL	1
FF. CHARCOAL PAN ASSEMBLY	1
F1. LEFT CHARCOAL PAN BRACKET	1
F2. RIGHT CHARCOAL PAN BRACKET	1
G. ASH TRAY	1
H. BOTTOM SHELF	1
J. SIDE SHELF	1
K. LEG, FRONT RIGHT	1
L. LEG, BACK RIGHT	1
M1. LEG, FRONT LEFT	1
N1. LEG, BACK LEFT	1
PP. COOKING GRATES	2
Q. WARMING GRATE	1
R. WHEELS	2
S. WHEEL AXLE	1
T. CHIMNEY	1
V. VENT	2
W. LEG FEET	2
X. CHARCOAL PAN ADJUSTMENT HANDLE	1
Y. CHARCOAL DOOR HANDLE ASSEMBLY	1
Z. CHIMNEY CAP	1
AA. LID HANDLE	1
AB. SMALL HANDLE	2
AC. CHARCOAL DOOR HANDLE KEY	1
AD. CHARCOAL DOOR FINISHING WASHER	1
AE. LID UPPER HINGE	4
AF. LID LOWER HINGE	4
AH. TEMPERATURE GAUGE WITH WASHER AND HEXNUT	1

OFFSET FIREBOX PARTS

	QTY
AM. OFFSET FIREBOX ASSEMBLY	1
AN. OFFSET FIREBOX LID	1
AP. OFFSET FIREBOX CHARCOAL PAN / GRATE ASSEMBLY	1
AQ. OFFSET FIREBOX COOKING GRATE	1

HARDWARE

	QTY
BA. FINISH WASHER	6
BC. M6 x 10MM BOLT	38
BD. M6 x 35MM BOLT	8
BE. M6 x 45MM BOLT	8
BF. M5 x 18MM BOLT	2
BG. M6 x 18MM STUD BOLT	2
BH. M6 HEXNUT	1
BJ. M10 LOCKING HEXNUT	1
BK. HINGE PIN	1
BL. COTTER PIN	1
BM. FLAT WASHER	1
BN. LOCKING WASHER	1
BQ. M4 x 10MM BOLT	1
BR. M4 HEXNUT	1
BS. M6 LOCKING HEXNUT	1



CARBON MONOXIDE HAZARD!

BURNING WOOD OR CHARCOAL PRODUCES CARBON MONOXIDE, WHICH HAS NO ODOR AND CAN CAUSE DEATH IF BURNED IN ENCLOSED AREAS. NEVER BURN WOOD OR CHARCOAL INSIDE HOMES, VEHICLES, TENTS OR ANY OTHER ENCLOSED AREAS.

HARDWARE AND SMALL PART LISTING

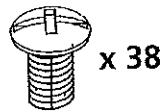

x 38

BC

(38) M6 x 10MM BOLT

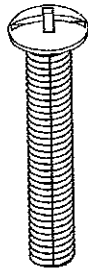

x 8

BD

(8) M6 x 35MM BOLT

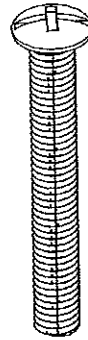

x 8

BE

(8) M6 x 45MM BOLT

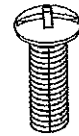

x 6

BF

(6) M5 x 18MM BOLT

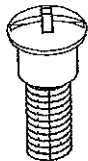

x 4

BG

(4) M6 x 18MM STUD BOLT

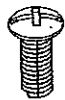

x 3

BQ

(3) M4 x 10MM BOLT



x 4

BK

(4) HINGE PIN

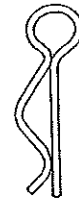

x 4

BL

(4) COTTER PIN



x 9

BH

(9) M6 HEXNUT

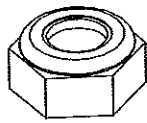

x 2

BJ

(2) M10 LOCKING HEXNUT



x 3

BR

(3) M4 HEXNUT



x 1

BS

(1) M6 LOCKING HEXNUT

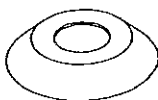

x 1

AD

(1) CHARCOAL DOOR FINISHING WASHER



x 6

BA

(6) HANDLE FINISHING WASHER



x 18

BM

(18) FLAT WASHER



x 18

BN

(18) LOCKING WASHER

PART LISTING

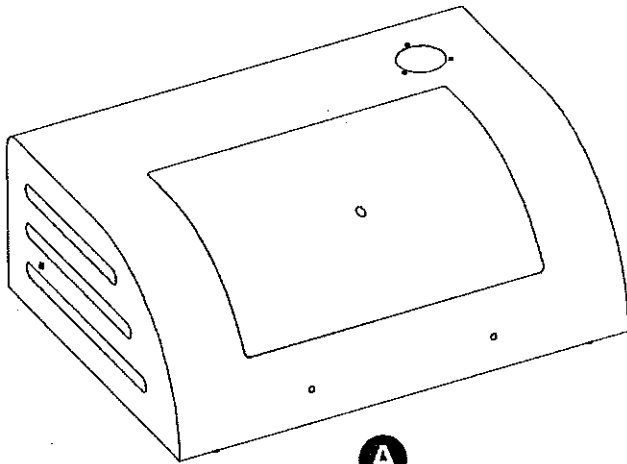

A
(1) LID

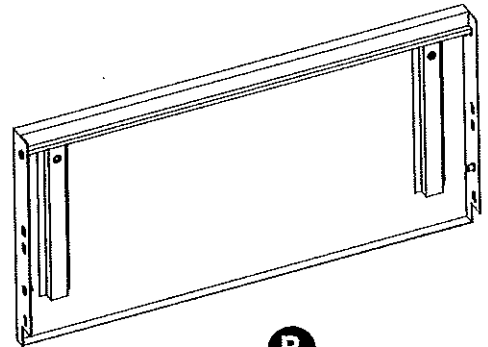

B
(1) BACK PANEL

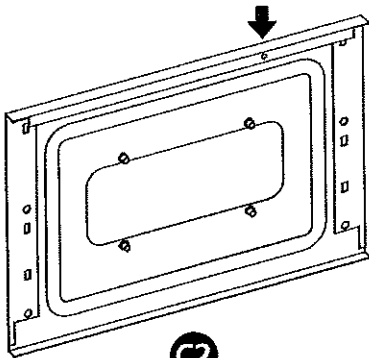

C2
(1) LEFT PANEL

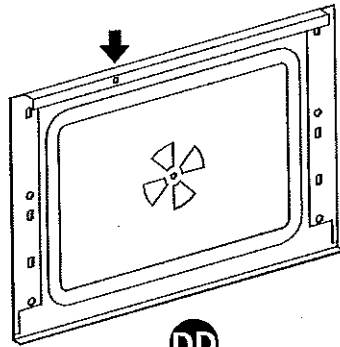

DD
(1) RIGHT PANEL

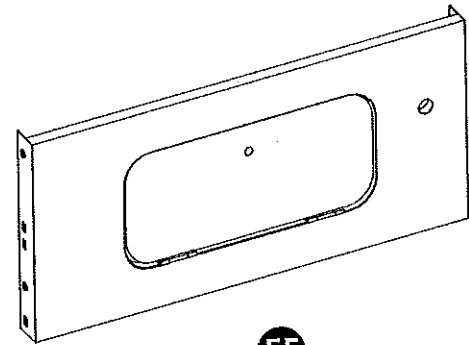

EE
(1) FRONT PANEL

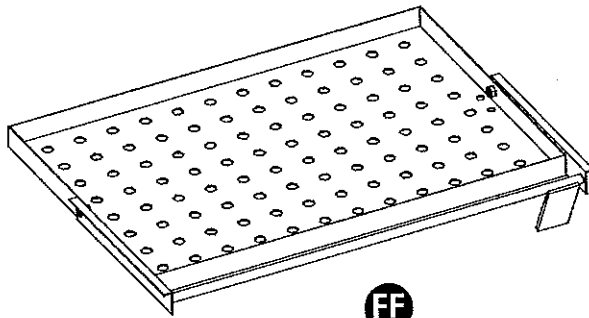

FF
(1) CHARCOAL PAN
ASSEMBLY

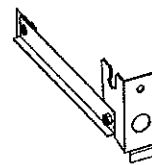

F1
(1) LEFT CHARCOAL
PAN BRACKET

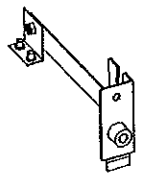

F2
(1) RIGHT CHARCOAL
PAN BRACKET

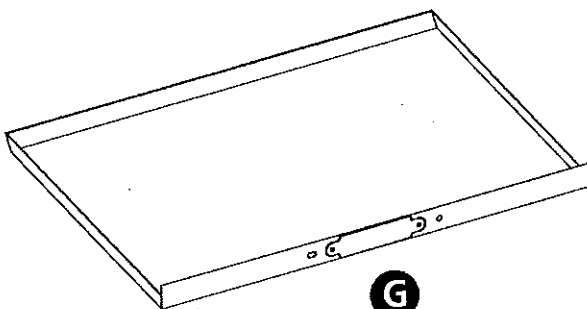

G
(1) ASH TRAY

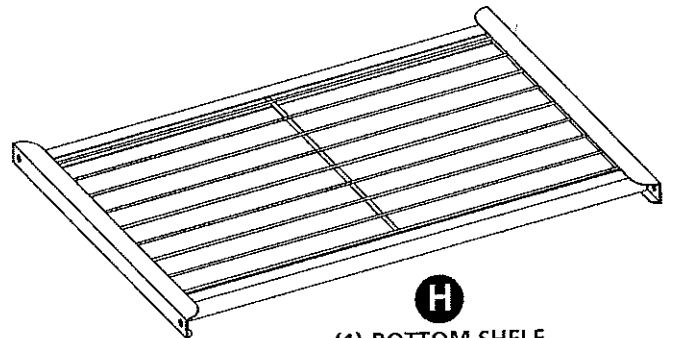

H
(1) BOTTOM SHELF

PART LISTING



K

(1) LEG, FRONT RIGHT



L

(1) LEG, BACK RIGHT



M1

(1) LEG, FRONT LEFT



N1

(1) LEG, BACK LEFT

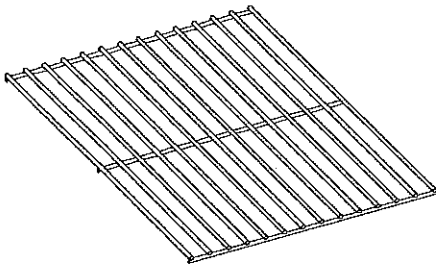

PP

(2) COOKING GRATES

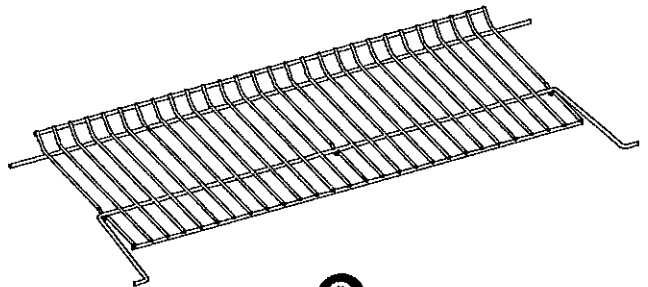

Q

(1) WARMING GRATE

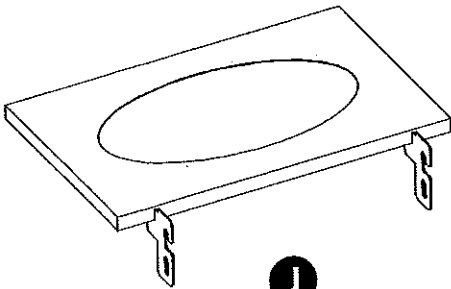

J

(1) SIDE SHELF

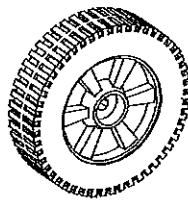

R

(2) WHEELS

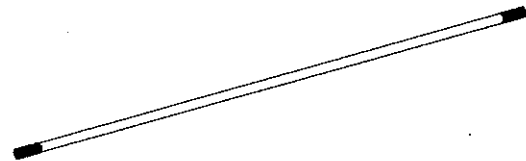

S

(1) WHEEL AXLE

PART LISTING

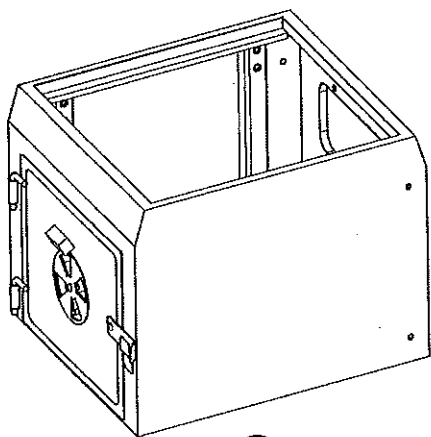

AM
(1) OFFSET FIREBOX ASSEMBLY

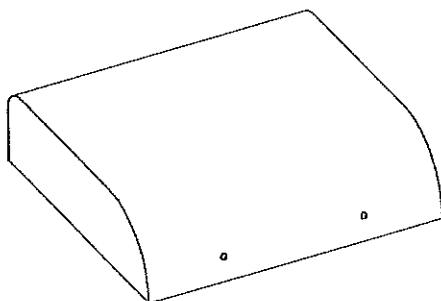

AN
(1) OFFSET FIREBOX LID

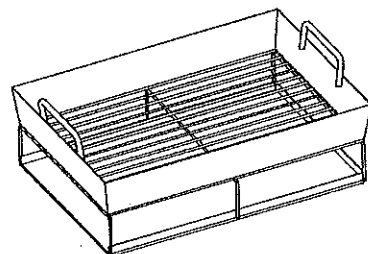

AP
(1) OFFSET FIREBOX CHARCOAL PAN / GRATE ASSEMBLY

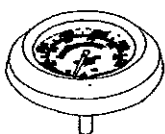

AH
(1) TEMPERATURE GAUGE WITH WASHER AND HEXNUT

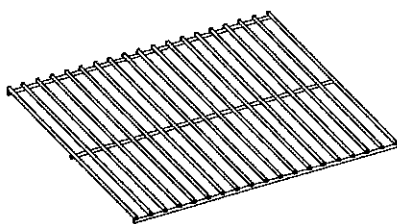

AQ
(1) OFFSET FIREBOX COOKING GRATE

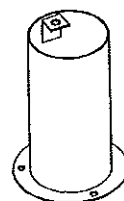

T
(1) CHIMNEY

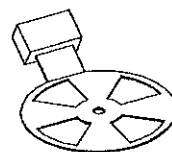

V
(1) VENT

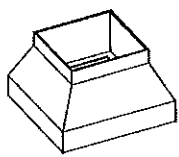

W
(2) LEG FEET

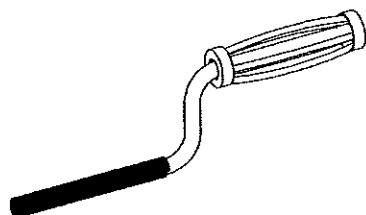

X
(1) CHARCOAL PAN ADJUSTMENT HANDLE ASSEMBLY

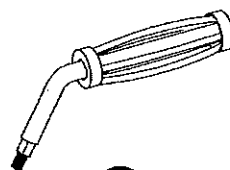

Y
(1) CHARCOAL DOOR HANDLE ASSEMBLY



Z
(1) CHIMNEY CAP



AA
(1) LID HANDLE



AB
(2) SMALL HANDLES

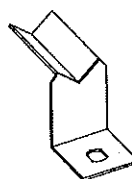

AC
(1) CHARCOAL DOOR HANDLE KEY

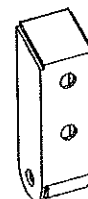

AE
(4) LID UPPER HINGES

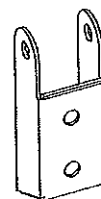

AF
(4) LID LOWER HINGES

VISTA CHARCOAL GRILL ASSEMBLY INSTRUCTIONS



A Phillips or plain screwdriver, adjustable wrench and needle nose pliers are needed for assembly.

Assembly time: 70 minutes

STEP 1: ASSEMBLE THE BACK PANEL TO THE LEFT AND RIGHT PANELS

Arrange the back panel [B], left [C2] and right [DD] panels as shown. (Make sure the left and right panels are on the correct side.) Align threaded inserts with the holes and assemble using (4) M6 x 10MM bolts [BC]. Tighten bolts securely.

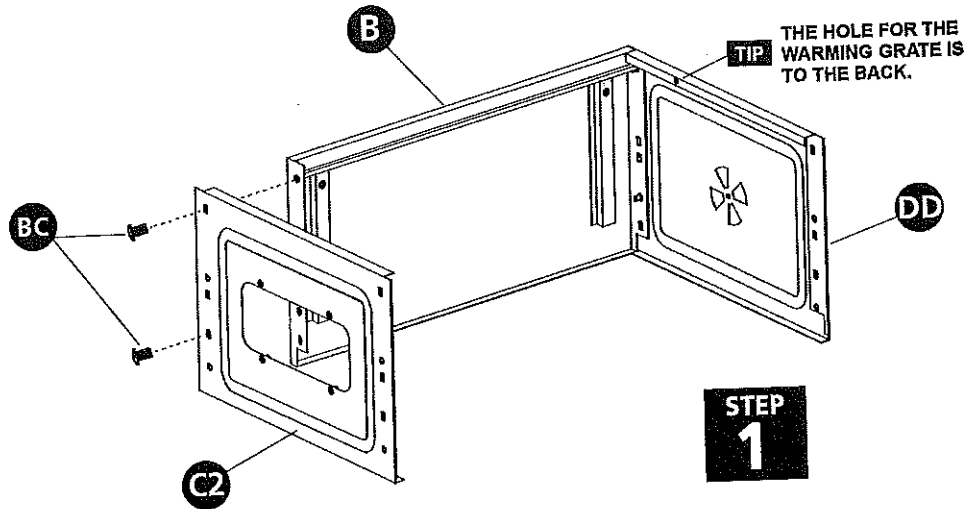

STEP 2: ASSEMBLE THE FRONT PANEL

Align front panel [EE] with the left and right panel threaded inserts. Assemble using (4) M6 x 10MM bolts [BC]. Tighten bolts securely.

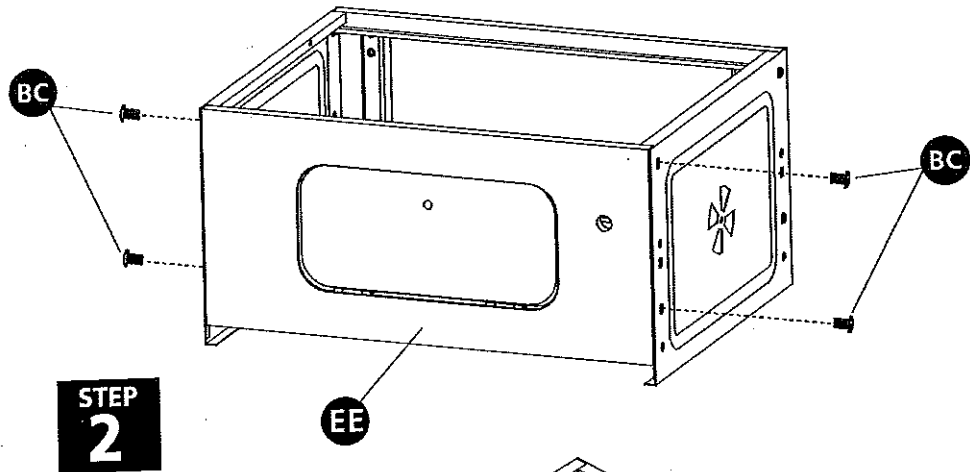

STEP 3: ASSEMBLE THE LEGS

Assemble the (4) legs [K,L,M1,N1] to the cooking chamber threaded inserts as shown using (2) M6 x 10MM bolts [BC] per leg.

Add the leg feet [W] to right side legs as shown by sliding onto leg end.

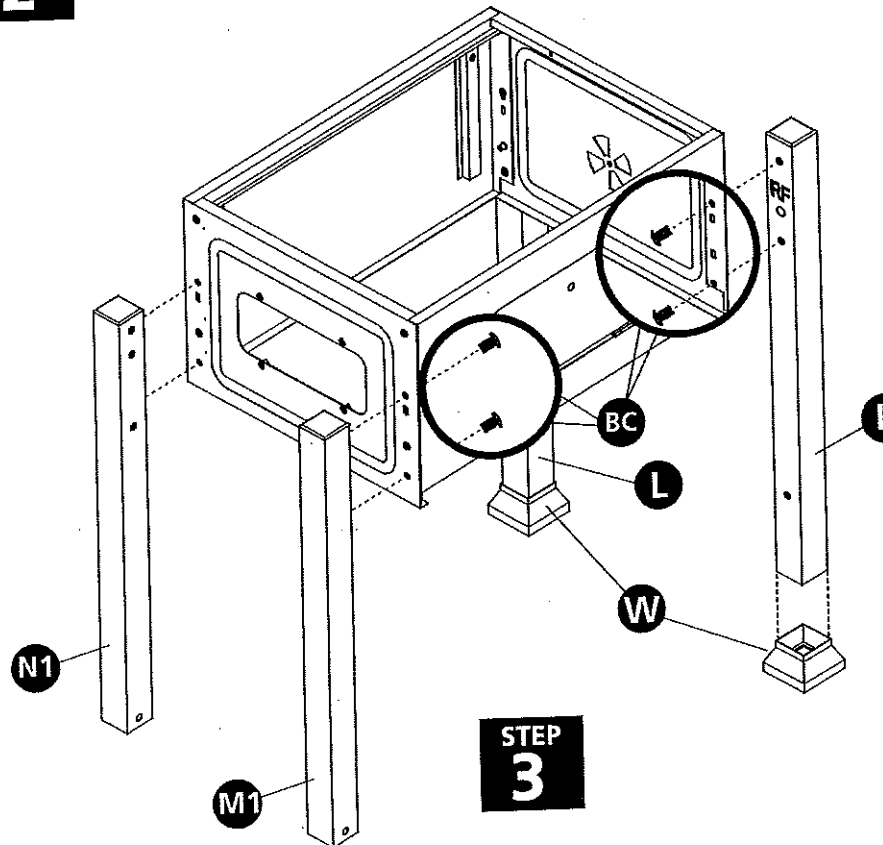

DO NOT RETURN PRODUCT TO THE STORE. IF YOU HAVE QUESTIONS OR HAVE TROUBLE WITH ASSEMBLY, PLEASE CALL 1-877-347-4557 FOR ASSISTANCE.

VISTA CHARCOAL GRILL ASSEMBLY INSTRUCTIONS

PAGE 8

LANDMANN
vista

STEP 4: ASSEMBLE THE BOTTOM SHELF

Align the bottom shelf [H] with the leg threaded inserts and assemble using (4) M6 x 10MM bolts [BC]. Tighten bolts securely.

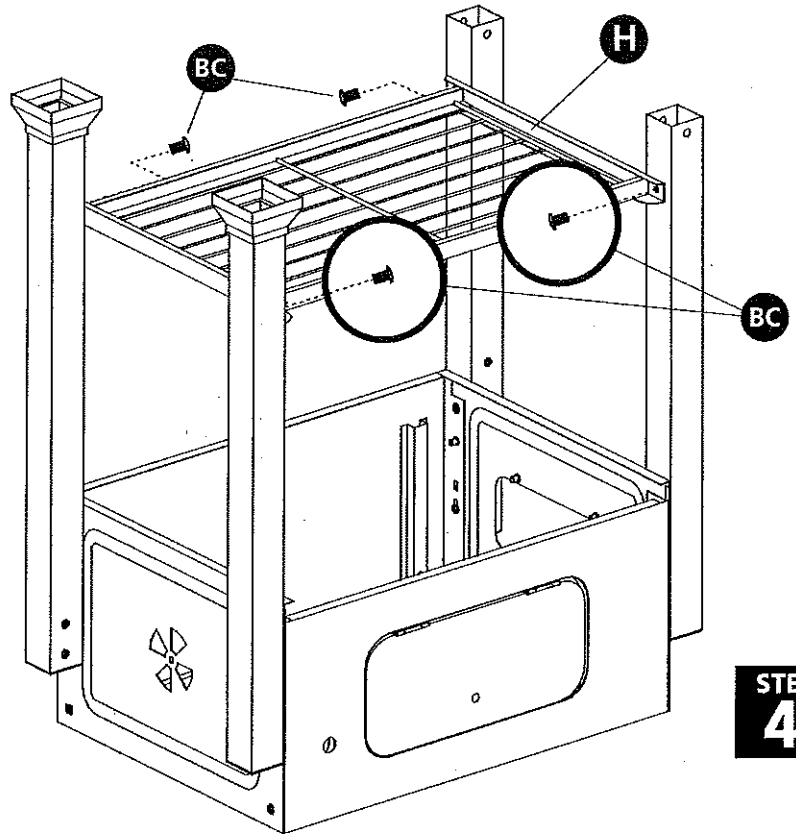

STEP 5: ASSEMBLE THE WHEELS AND WHEEL AXLE

Place wheel axle [S] into the left side leg holes. Slide the (2) wheels [R] onto the axle and assemble using (2) M10 locking hexnuts [BJ]. Tighten until the axle threads reach the plastic on the locking hexnut.

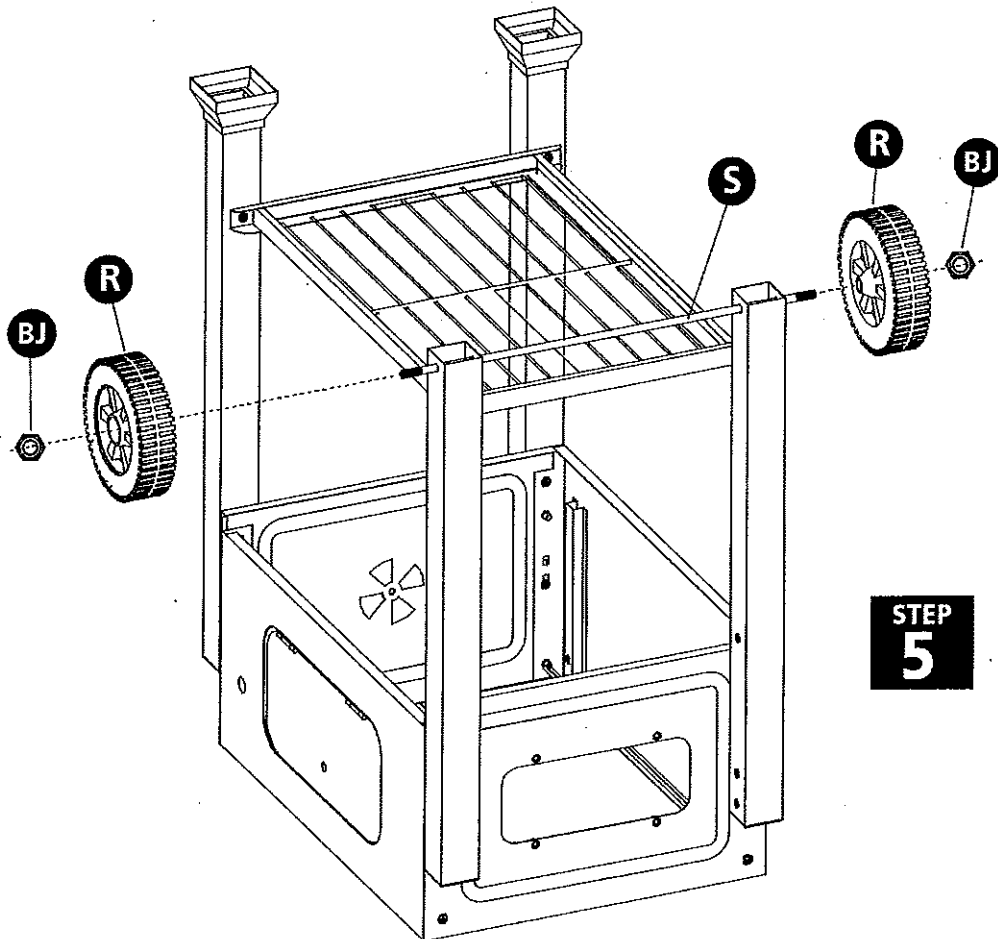

**DO NOT RETURN PRODUCT TO THE STORE.
IF YOU HAVE QUESTIONS OR HAVE
TROUBLE WITH ASSEMBLY, PLEASE CALL
1-877-347-4557 FOR ASSISTANCE.**

VISTA CHARCOAL GRILL ASSEMBLY INSTRUCTIONS



STEP 6: ASSEMBLE THE CHARCOAL PAN ASSEMBLY

Assemble the left and right charcoal pan brackets [F1,F2] to the charcoal pan [FF] using (4) M6 x 10MM [BC] bolts. See STEP 6.

Arrange the charcoal pan assembly [FF] as shown and move into the firebox. See STEP 6.

Assemble the charcoal pan assembly [FF] to the panel [EE] by inserting the tab into the slot and secure using (1) M6 x 10MM [BC] bolt per side. See STEP 6A.

Rotate the torque bar up and put the torque bar into the channels to complete the assembly as shown. See STEP 6B.

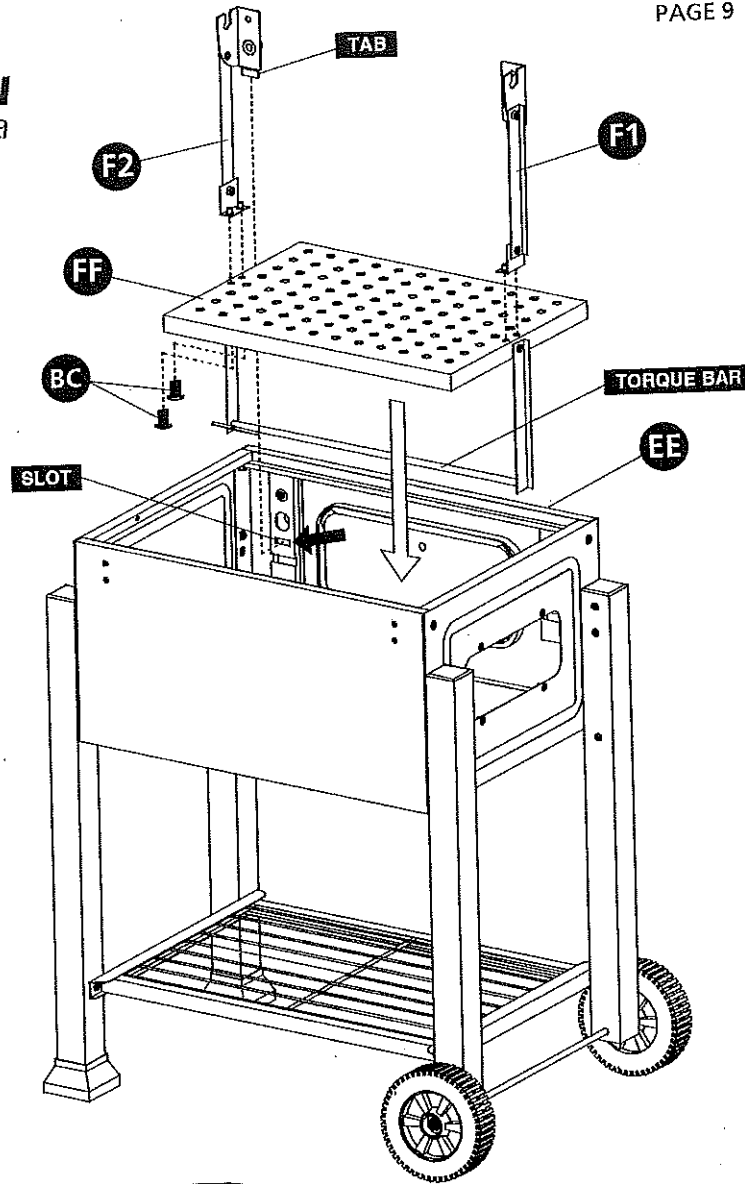

STEP 6

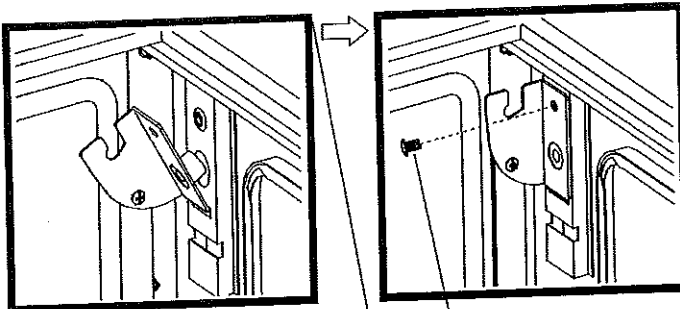

BC

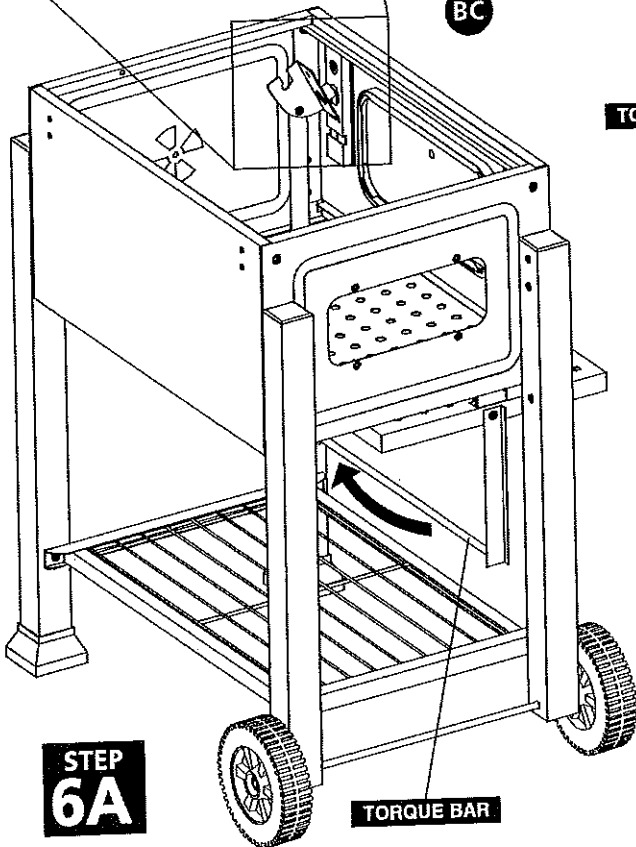

STEP 6A

TORQUE BAR

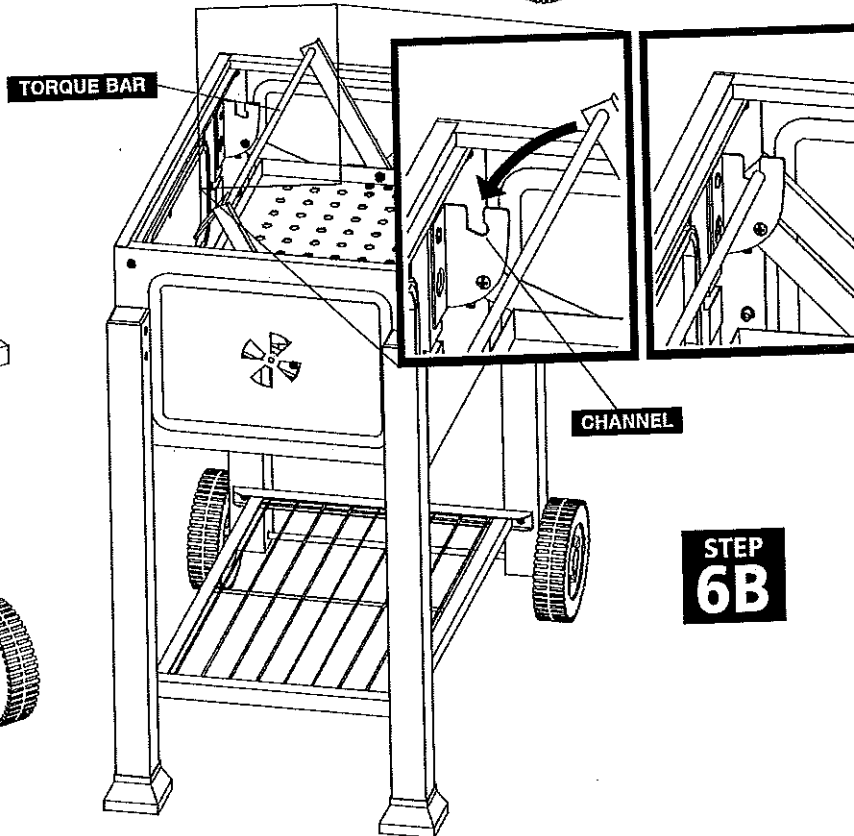

CHANNEL

STEP 6B

VISTA CHARCOAL GRILL ASSEMBLY INSTRUCTIONS

STEP 7: ASSEMBLE THE CHARCOAL PAN ADJUSTMENT HANDLE

Thread the charcoal pan adjustment handle [X] into the threaded sleeve. Turn the handle and make sure the pan moves up and down freely.

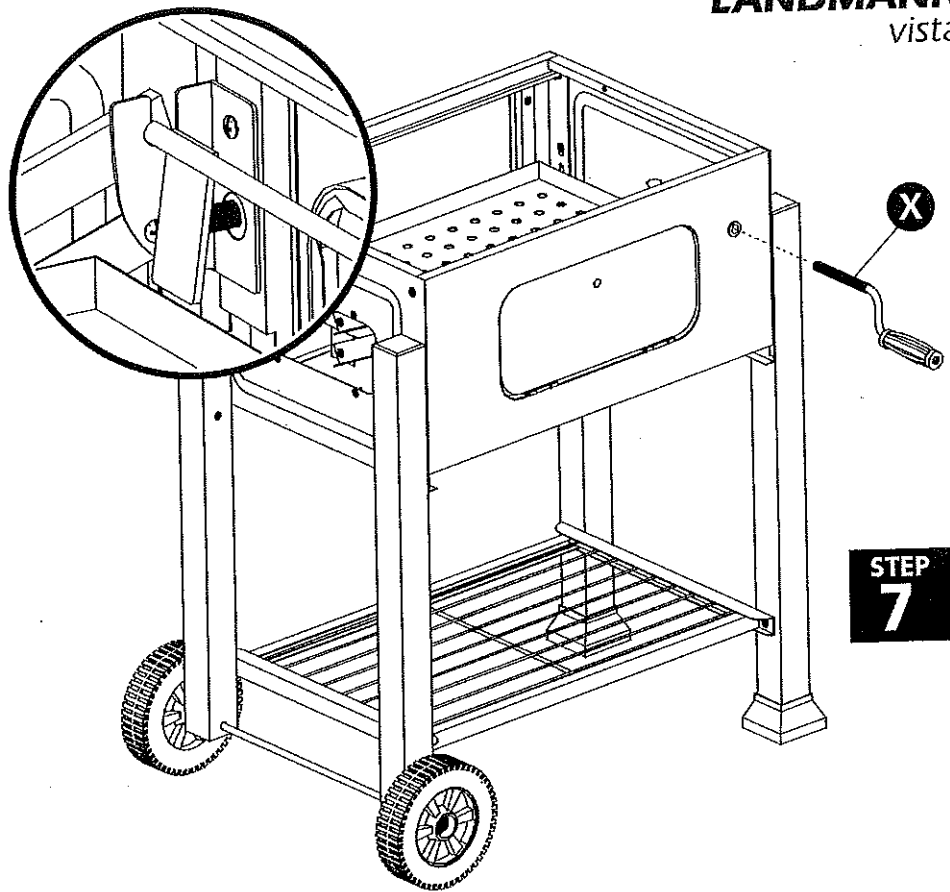

**STEP
7**

STEP 8: ASSEMBLE THE CHARCOAL DOOR HANDLE ASSEMBLY

Assemble the charcoal door handle [Y] to the door as shown. Place the finishing washer [AD] between the door and the handle on the outside. The handle key [AC] will lock onto the straight sections on the handle. Assemble using (1) flat washer [BM], (1) locking washer [BN] and (1) M6 hexnut [BH].

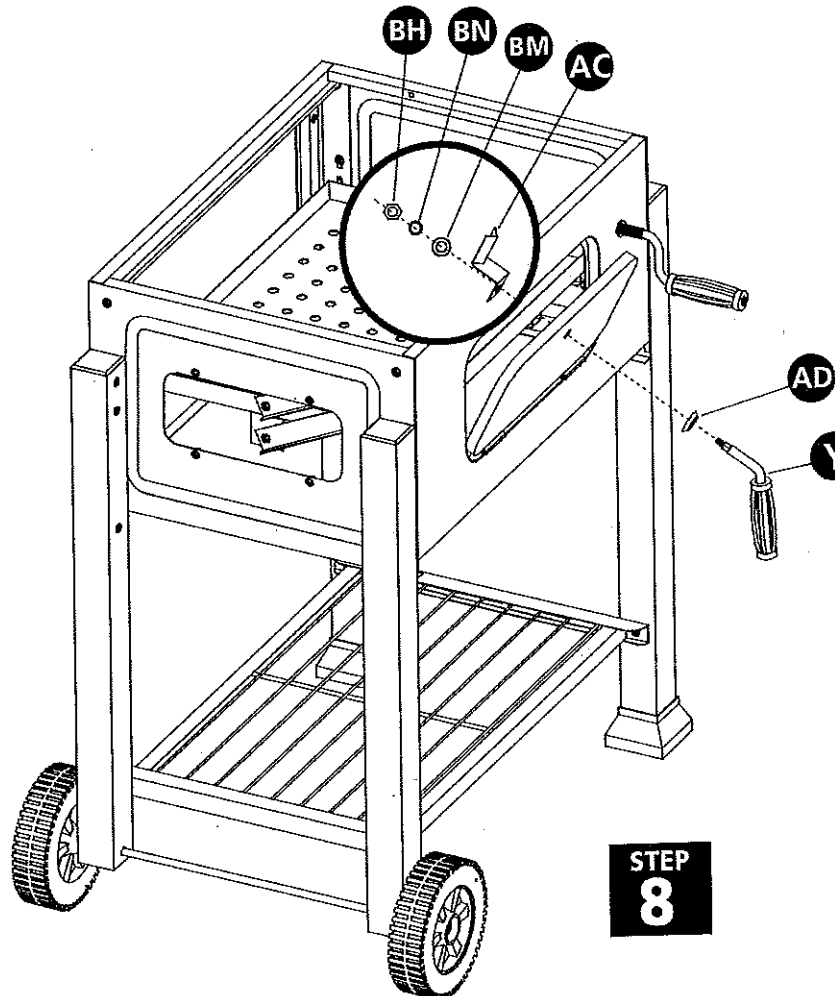

**STEP
8**

**DO NOT RETURN PRODUCT TO THE STORE.
IF YOU HAVE QUESTIONS OR HAVE
TROUBLE WITH ASSEMBLY, PLEASE CALL
1-877-347-4557 FOR ASSISTANCE.**

STEP 9: ASSEMBLE THE VENT

Assemble the vent [V] to the right panel of the cooking chamber. Use (1) M6 x 10MM bolt [BC] and (1) M6 locking hexnut [BS]. Tighten but only enough to allow the vent to move and stay in position.

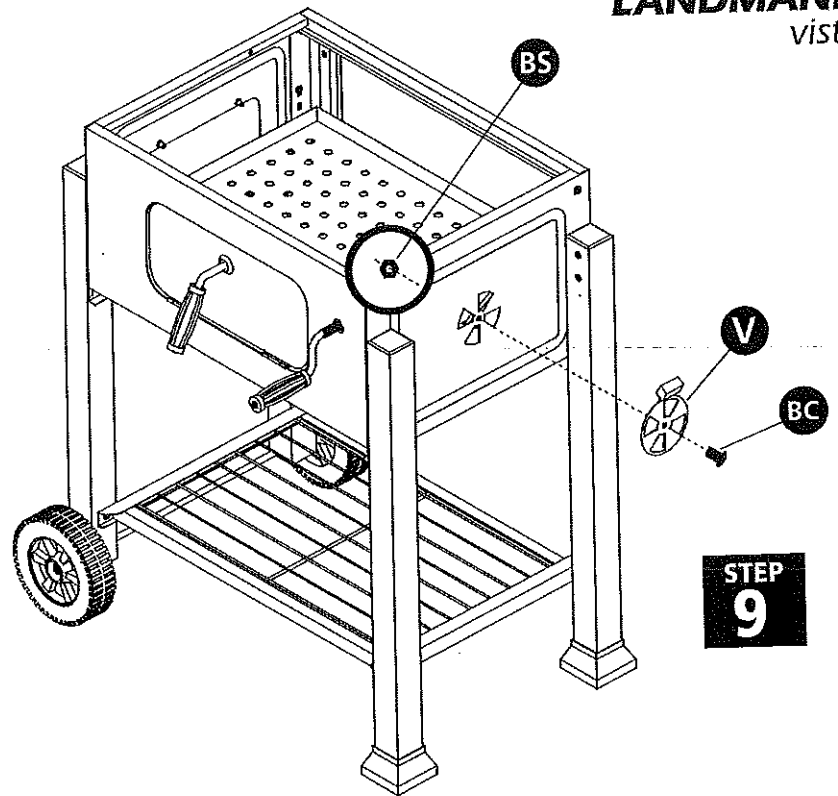

**STEP
9**

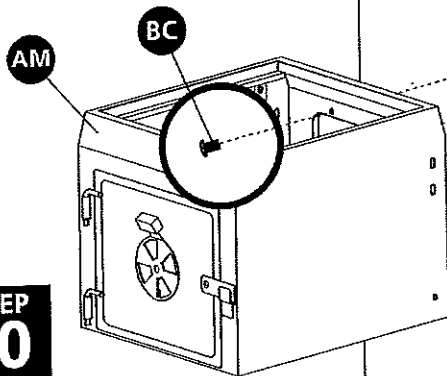

**STEP
10**

STEP 10: ASSEMBLE THE OFFSET FIREBOX

Place the offset firebox assembly [AM] to the left side of the grill and align with the holes. Assemble using (4) M6 x 10MM bolts [BC].

Use (6) M6 x 10MM bolts [BC] to assemble the offset firebox assembly to the legs.

Tighten all bolts securely.

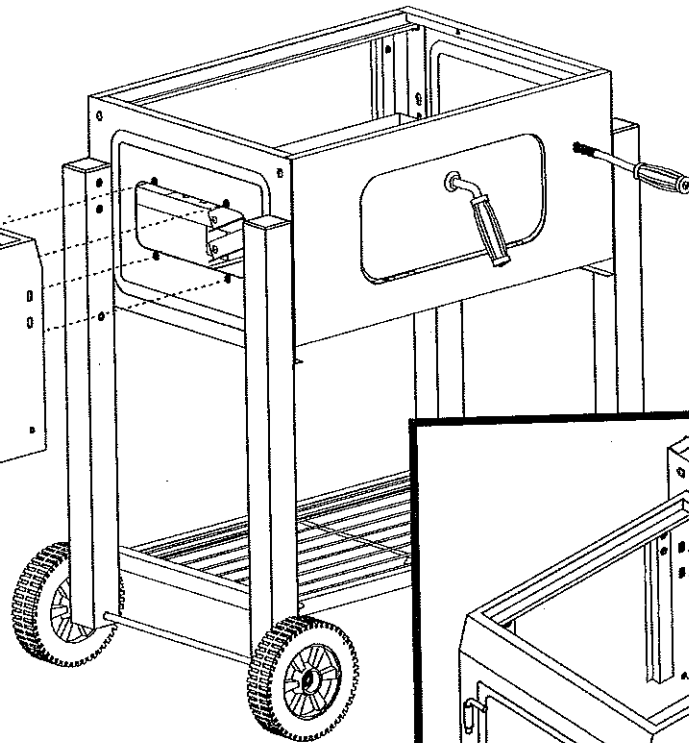

**STEP
10A**

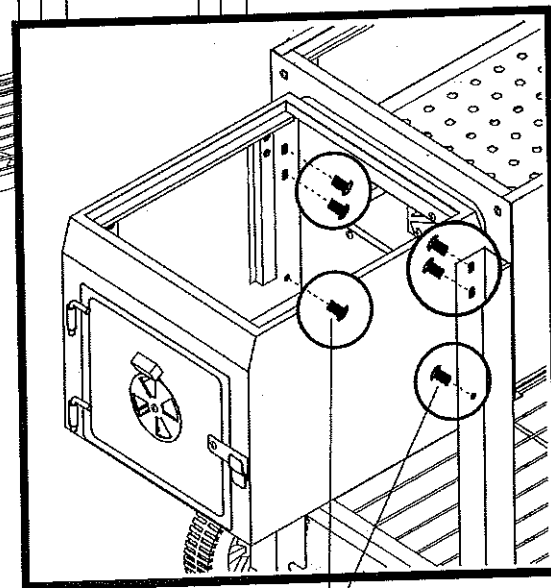

BC

VISTA CHARCOAL GRILL ASSEMBLY INSTRUCTIONS

LANDMANN
vista

STEP 11: ASSEMBLE THE OFFSET FIREBOX LID

Assemble the (2) lid lower hinges [AF] to the offset firebox. Align with the holes (threaded inserts) and use (2) M6 x 45MM bolts [BE], (2) flat washers [BM] and (2) locking washers [BN] per side. Do not tighten, keep loose.

Next assemble the (2) lid upper hinges [AE] to the back of the offset firebox lid [AN]. Align with the holes and use (2) M6 x 35MM bolts [BD], (2) flat washers [BM], (2) locking washers [BN] and (2) M6 hexnuts [BH] per side. Do not tighten, keep loose.

Carefully place the offset lid [AN] on the offset firebox and align the hinges. Insert hinge pins [BK] into the hinges and push a cotter pin [BL] into each hinge pin to secure.

Now tighten all bolts making sure the lid is in alignment with the offset firebox.

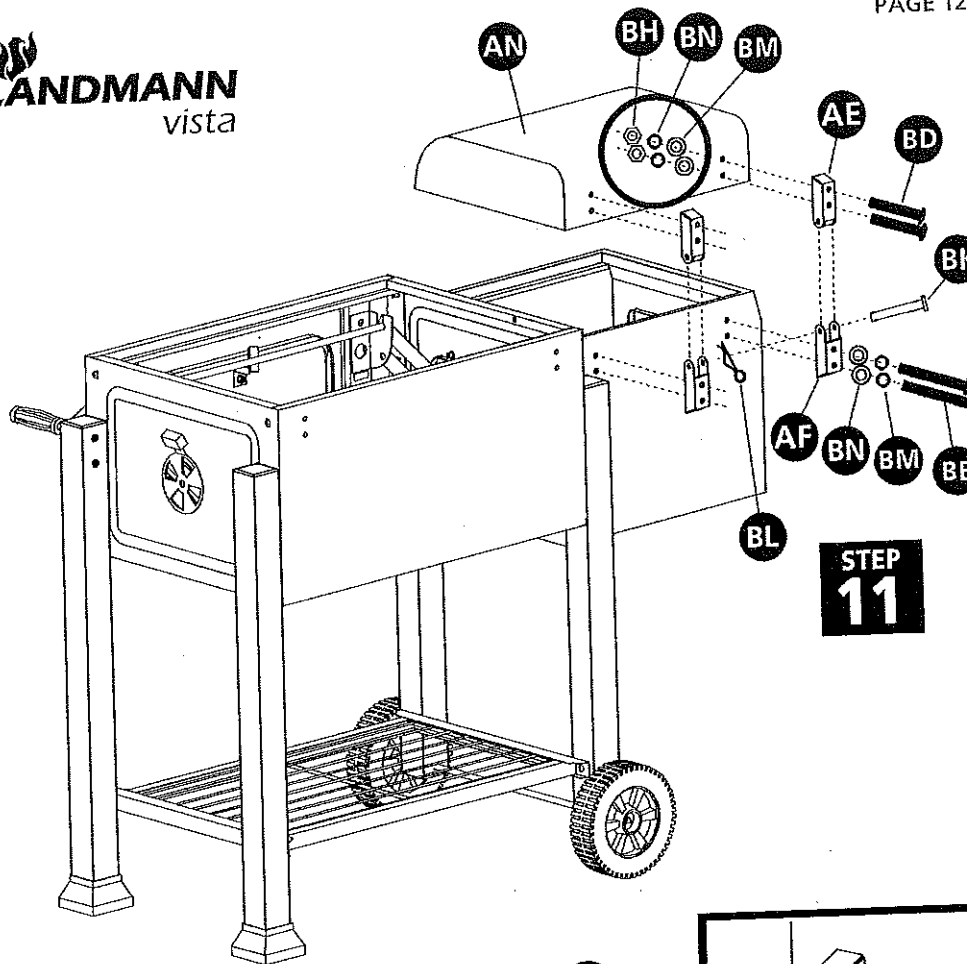

**STEP
11**

STEP 12: ASSEMBLE THE LID

Assemble the (2) lid lower hinges [AF] to the back panel. Align with the holes (threaded inserts) and use (2) M6 x 45MM bolts [BE], (2) flat washers [BM] and (2) locking washers [BN] per side. Do not tighten, keep loose.

Next assemble the (2) lid upper hinges [AE] to the back of the lid [A]. Align with the holes and use (2) M6 x 35MM bolts [BD], (2) flat washers [BM], (2) locking washers [BN] and (2) M6 hexnuts [BH] per side. Do not tighten, keep loose.

Carefully place the lid [A] on the cooking chamber and align the hinges. Insert hinge pins [BK] into the hinges and push a cotter pin [BL] into each hinge pin to secure.

Now tighten all bolts making sure the lid is in alignment with the cooking chamber.

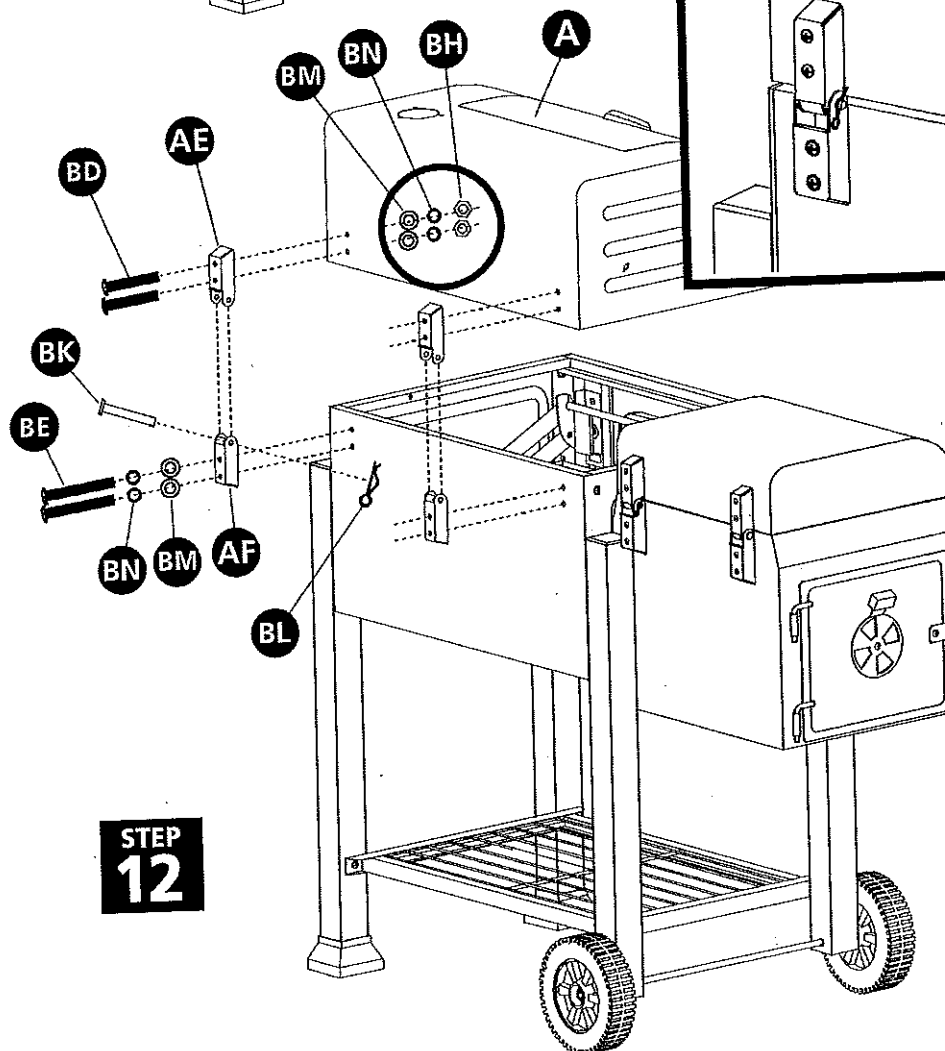

**STEP
12**

**DO NOT RETURN PRODUCT TO THE STORE.
IF YOU HAVE QUESTIONS OR HAVE
TROUBLE WITH ASSEMBLY, PLEASE CALL
1-877-347-4557 FOR ASSISTANCE.**

VISTA CHARCOAL GRILL ASSEMBLY INSTRUCTIONS

STEP 13: ASSEMBLE THE CHIMNEY

Insert the chimney [T] from inside the lid through the hole. Assemble with (3) M4 x 10MM bolts [BQ] and (3) M4 hexnuts [BR]. Tighten bolts securely.

Place the chimney cap [Z] on the chimney and assemble using (1) M6 x 10MM bolt [BC], (1) flat washer [BM] and (1) lock washer [BN]. See STEP 13A. Tighten enough to allow the cap to move.

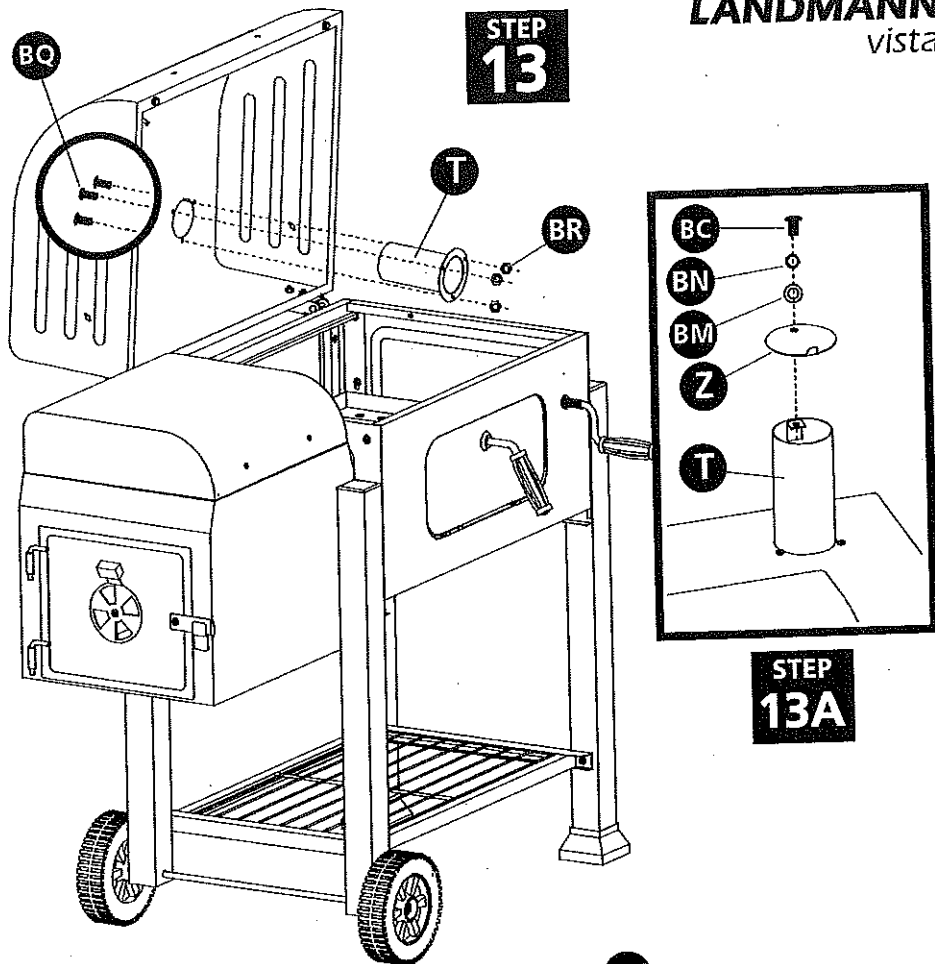

STEP 14: ASSEMBLE THE HANDLES, ASH TRAY AND TEMPERATURE GAUGE

Assemble the lid handle [AA] to the lid [A] using (2) M5 x 16MM bolts [BF] and (2) finishing washers [BA].

Assemble (1) small handle [AB] to the offset firebox lid [AN] using (2) M5 x 16MM bolts [BF] and (2) finishing washers [BA].

Assemble (1) small handle [AB] to the ash tray [G] using (2) M5 x 16MM bolts [BF] and (2) finishing washers [BA].

Insert ash tray into the bottom of the cooking chamber.

Remove the washer and hexnut from the temperature gauge [AH]. Insert the gauge into the lid and assemble using the washer and hexnut.

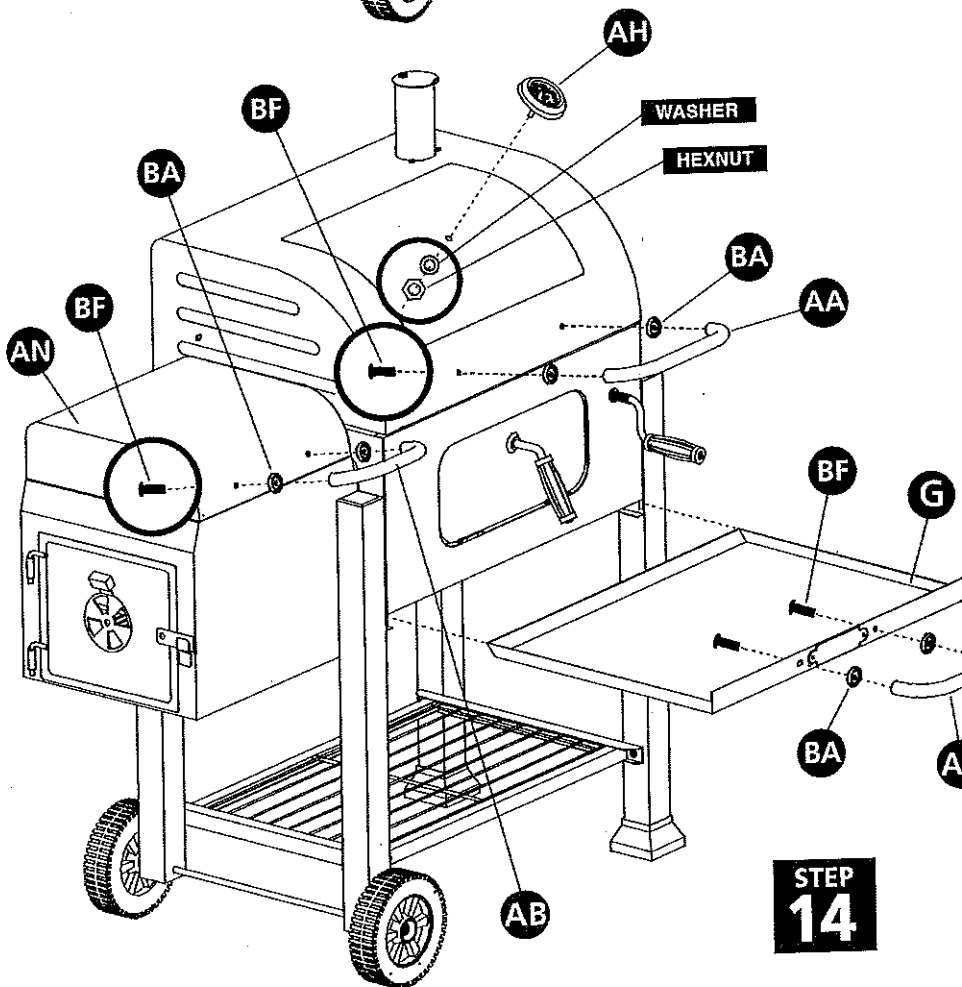

⚠ WARNING!

DO NOT OPERATE GRILL WITHOUT ASH TRAY IN PLACE. DO NOT OPEN ASH TRAY DURING USE. KEEP ASH TRAY CLOSED UNTIL ALL ASHES HAVE COOLED.

DO NOT RETURN PRODUCT TO THE STORE. IF YOU HAVE QUESTIONS OR HAVE TROUBLE WITH ASSEMBLY, PLEASE CALL 1-877-347-4557 FOR ASSISTANCE.

STEP 14

VISTA CHARCOAL GRILL ASSEMBLY INSTRUCTIONS

STEP 15: ASSEMBLE THE SIDE SHELF

Align side shelf in a vertical position as shown and assemble using (2) M6 x 18MM stud bolts [BG]. Make sure the shelf opening engages on the stud so the shelf can rotate.

Assemble (2) M6 x 18MM stud bolts [BG] to the legs for locking the shelf in the upright position.

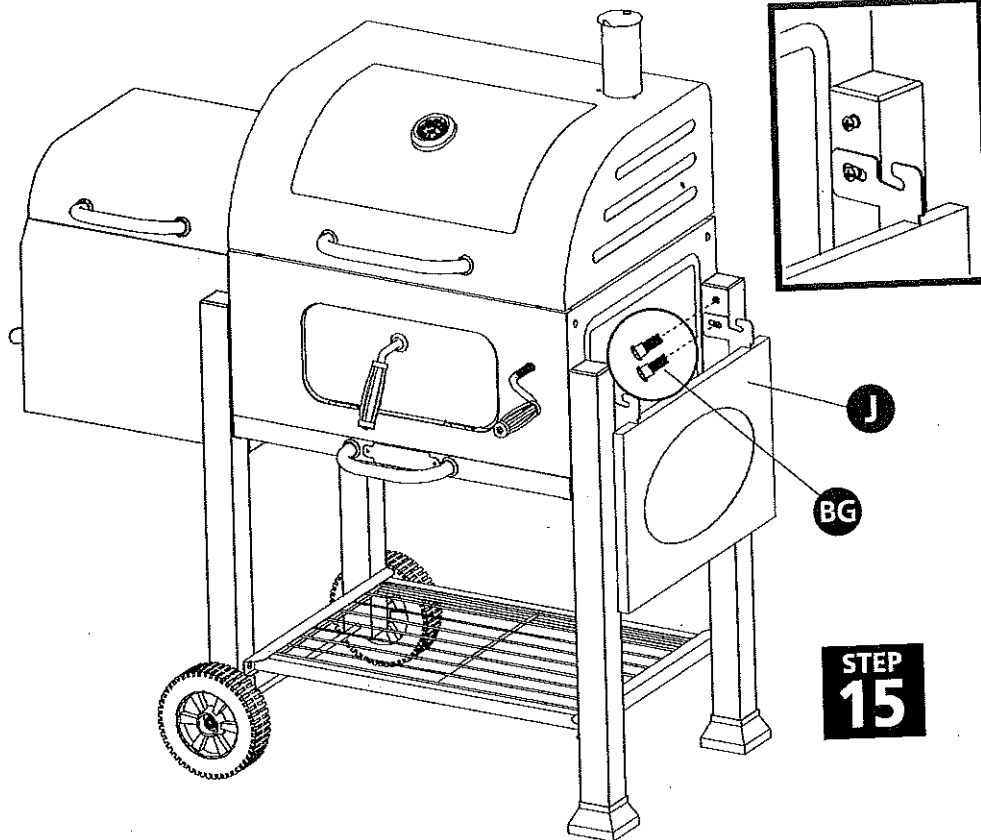

STEP 16: INSERT THE OFFSET FIREBOX CHARCOAL PAN

Slide the offset firebox charcoal pan [AP] between the rails on the bottom of the offset firebox. Keep the pan within the bottom rails. The rails keep the pan from touching the firebox sides.

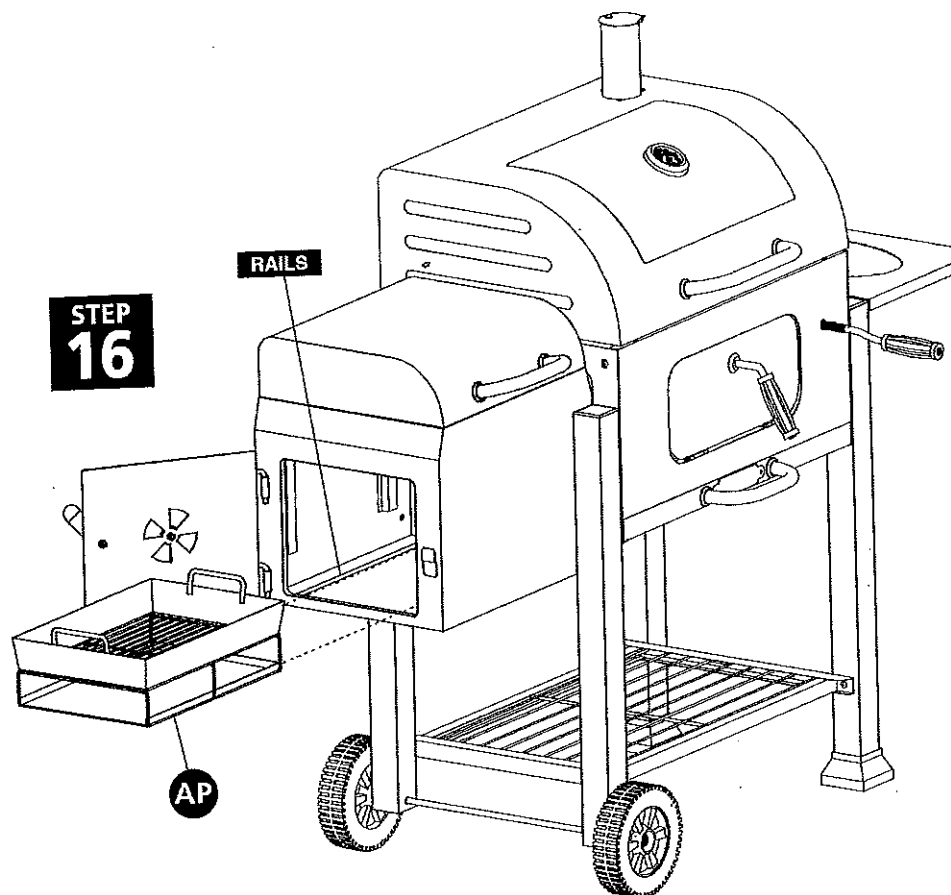

**DO NOT RETURN PRODUCT TO THE STORE.
IF YOU HAVE QUESTIONS OR HAVE
TROUBLE WITH ASSEMBLY, PLEASE CALL
1-877-347-4557 FOR ASSISTANCE.**

VISTA CHARCOAL GRILL ASSEMBLY INSTRUCTIONS

LANDMANN
vista

STEP 17: PLACE THE COOKING GRATES

Place the (2) cooking grates [PP] on the grill as shown.

Place the offset firebox cooking grate [AQ] on the offset firebox.

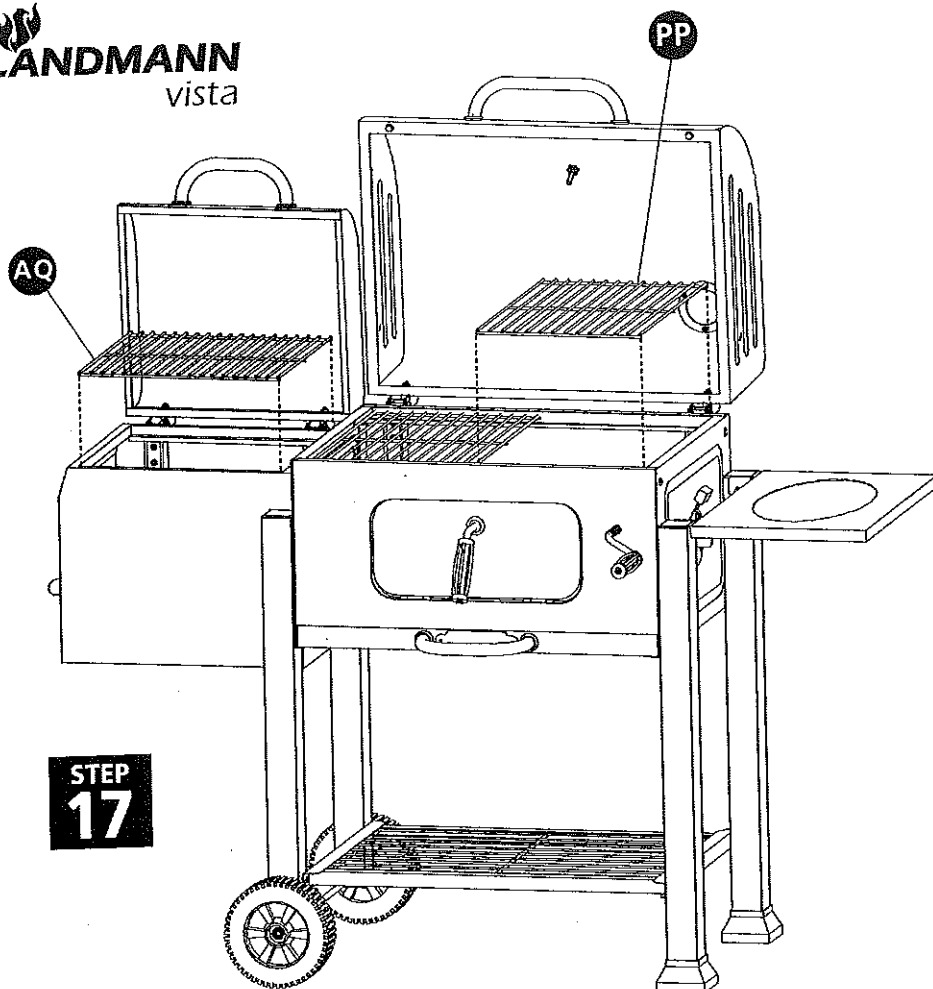

STEP
17

STEP 18: ASSEMBLE THE WARMING GRATE

Assemble the warming grate [Q] to the cooking chamber by aligning the rods and legs with holes. Assemble as shown.

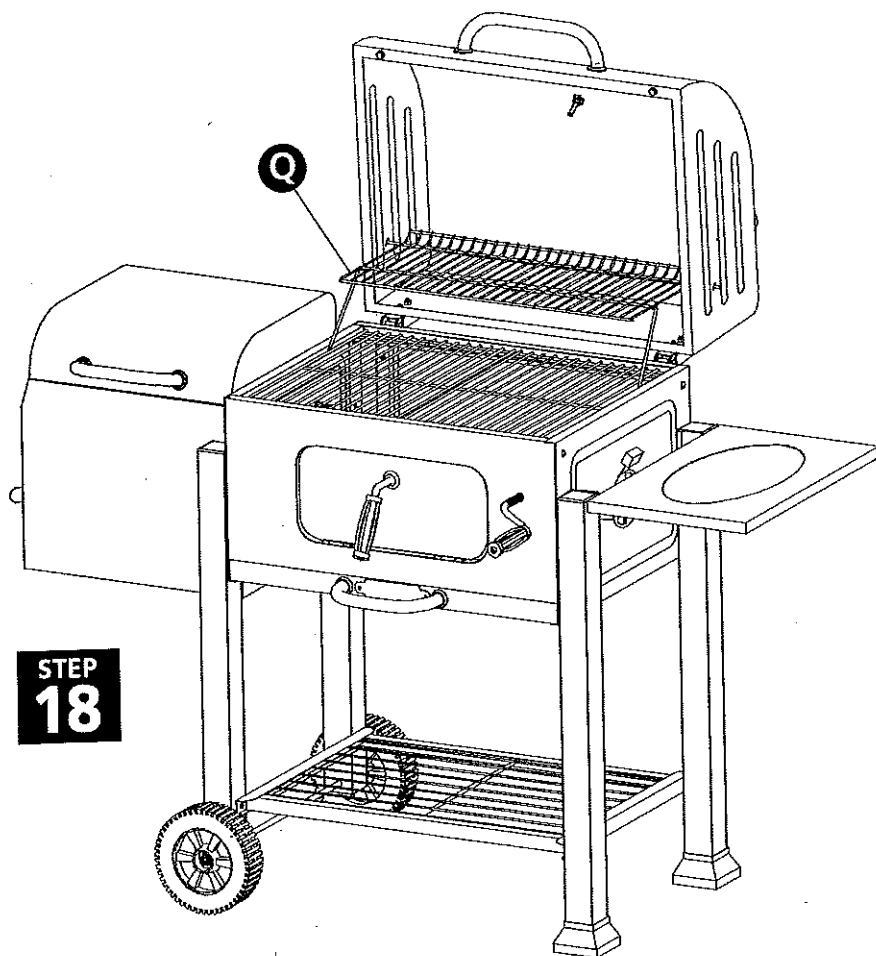

STEP
18

**DO NOT RETURN PRODUCT TO THE STORE.
IF YOU HAVE QUESTIONS OR HAVE
TROUBLE WITH ASSEMBLY, PLEASE CALL
1-877-347-4557 FOR ASSISTANCE.**

LANDMANN
vista

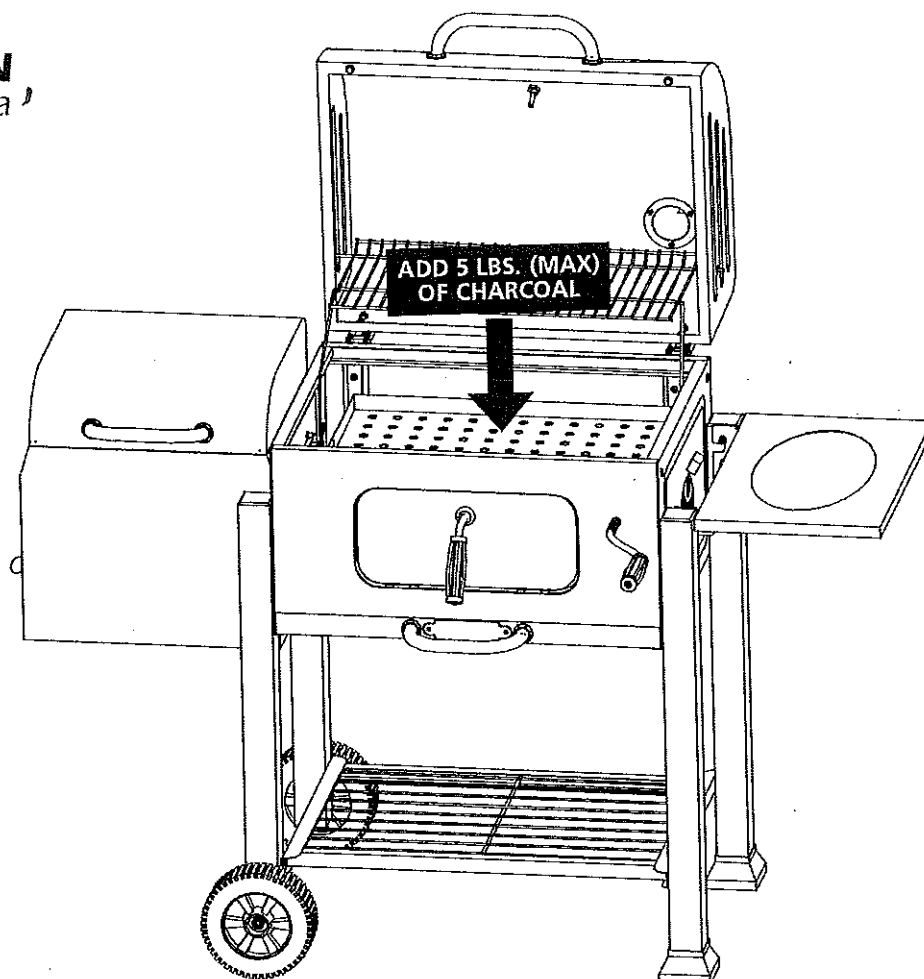

VISTA CHARCOAL GRILL OPERATING INSTRUCTIONS



WARNING !

This grill becomes very hot and possibly the handles. Use caution working around the grill. Use mittens or oven gloves when opening the lid, access door, ash tray or adjusting the vents during use.

1. Pour the desired amount (5 lbs. MAX.) of charcoal onto the charcoal pan.
2. Keep all charcoal inside the pan. Do not allow charcoal to come in contact with the sides. Pick up any loose charcoal that falls onto the ash pan.
3. Adjust all vents to full open and keep the lid open.
4. Light charcoal according to the charcoal manufacturer instructions.
5. After the flames have disappeared from the charcoal, close the lid, keep all vents full open.
6. After about 10-15 minutes, check the charcoal to see if the coals have turned gray and the initial starter odors are gone.
7. Adjust the charcoal or spread the charcoal evenly across the charcoal pan if necessary.
8. The optimum cooking temperature is 300-350 degrees. The vents may need to be adjusted more open or more closed for the desired temperature. The type charcoal and the climate conditions can affect the grill temperature.
9. Carefully wipe the cooking grate surfaces with vegetable oil to keep the food from sticking.
10. Add meat and food as desired to the cooking grates. Cook food to your personal preference.
11. Add charcoal as needed through the access door.



The adjustable charcoal pan can be moved to within a few inches of the cooking grates allowing you to sear the meat and lock in the juices. Searing takes only a few minutes on each side. Don't allow the meat or food to burn. After searing, crank the charcoal pans back down from the top and cook the food to your personal preference.

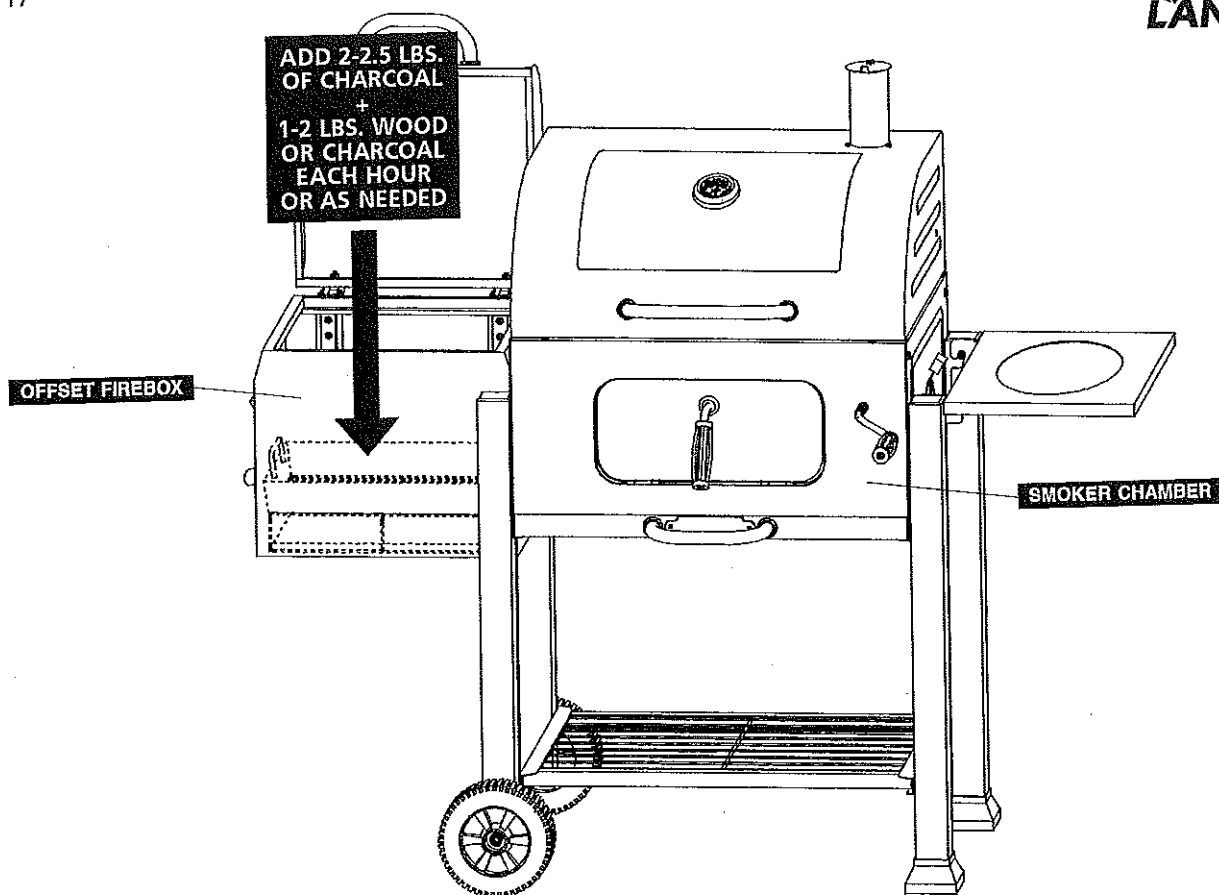

VISTA OFFSET FIREBOX SMOKER OPERATING INSTRUCTIONS

WARNING !

This grill becomes very hot and possibly the handles. Use caution working around the grill. Use mittens or oven gloves when opening the lid, access doors, ash tray or adjusting the vents during use.

The fire is in the offset firebox and the food is cooked in the smoker chamber (main grill). The smoke and indirect heat pass through the opening between the offset firebox and the smoker chamber. Follow these steps for cooking with smoke and indirect heat. Note that most food needs several hours to cook with this method. These are the basic instructions.

1. Pour the desired amount (2-2.5 lbs.) of charcoal onto the offset firebox charcoal pan / grate assembly. Keep charcoal inside the pan. **DO NOT ALLOW ANY CHARCOAL TO TOUCH THE PANEL SIDES.**
2. Adjust all vents to full open and keep the offset firebox lid open.
3. Light charcoal according to the charcoal manufacturer instructions.
4. After the flames have disappeared from the charcoal, close the lid, but keep all vents open.
5. After about 10-15 minutes, check the charcoal to see that it has ashed over (turned gray) and the initial starter odors are gone.
6. Now carefully add about 1-2 lbs. of wood chunks to the fire. **Note!** Keep all wood chunks away from the firebox side panels. Keep firewood inside the pan. **DO NOT ALLOW ANY WOOD TO TOUCH THE PANEL SIDES.** The best types of wood for flavor and smoke are pecan, hickory and mesquite. The smoke will be heavy at first and after a short while will burn with less smoke.
7. Carefully wipe the cooking grate surfaces with vegetable oil keep the food from sticking.
8. When the smoker chamber temperature reaches 200-250 degrees, add meat and food as desired to the cooking grate. Cook food to your personal preference.
9. Adjust the vents as needed to control the temperature in the smoker chamber.
10. As a general rule, you will need to add more wood when the temperature drops below 200 degrees. 1-2 lbs of wood will burn for about 1 hour. Each pound of meat will take 1 hour to cook. These are general rules and will vary depending on your actual conditions.



FOOD TEMPERATURES

If you are unsure about when food is done, use this chart as a guide for measuring properly cooked meat temperatures.

Use a high quality meat thermometer with probe to measure the meat temperature. Push probe into the thickest part of the meat to get an accurate measurement. The temperature gauge on the grill measures the air temperature of the grill cooking chamber, not the food temperature.

Steaks & Roasts

Medium rare	145°F
Medium	160°F
Well done	170°F

Bison

Medium rare	145°F
Medium	160°F
Well done	170°F

Lamb

Medium rare	145°F
Medium	160°F
Well done	170°F

Ground Meats

Beef, Pork	160°F
Turkey	165°F

Pork

Medium	160°F
Well done	170°F

Poultry

Turkey	165°F
Chicken	165°F

Fish145°F

Egg Dishes160°F

If you still have questions, please see the USDA contact info below.

USDA Meat and Poultry Hotline
 1-888-674-6854
 TTY: 1-800-256-7072
www.IsItDoneYet.gov

LANDMANN
vista



⚠ WARNING!
NEVER USE GASOLINE, ALCOHOL OR VOLATILE FLUIDS TO START OR RESTART FIRES.



⚠ HOT!
⚠ WARNING!
HOT SURFACES DURING USE! USE MITTENS OR GLOVES ON THESE PARTS.

⚠ WARNING!
DO NOT OPERATE GRILL WITHOUT ASH TRAY IN PLACE. DO NOT OPEN ASH TRAY DURING USE. KEEP ASH TRAY CLOSED UNTIL ALL ASHES HAVE COOLED.

Congratulations on your purchase of the Vista Charcoal Grill! At Landmann USA, we strive to provide you with an easy to use, easy to assemble product. However, in the unlikely event your package should have a missing or defective part, please contact us at:
customerservice@landmann-usa.com
-OR-
1-877-347-4557 M-F 8-5 ET.
Proof of purchase may be required.
Thank you!

ACCESSORIES FOR VISTA



COVER

MODEL 150137 This high quality cover keeps out the elements.

Please visit our website at:
www.landmann-usa.com
-OR-
Call customer service toll free at:
1-800-321-3473

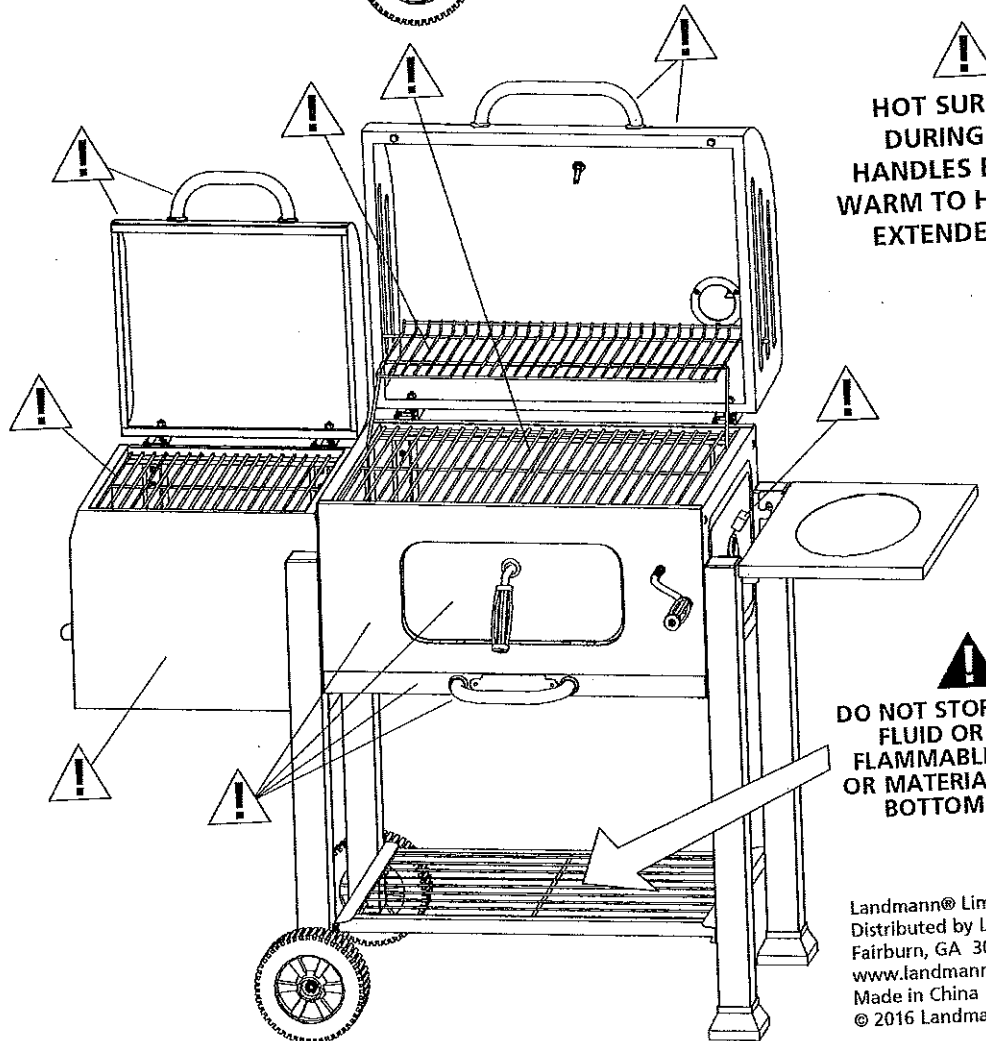
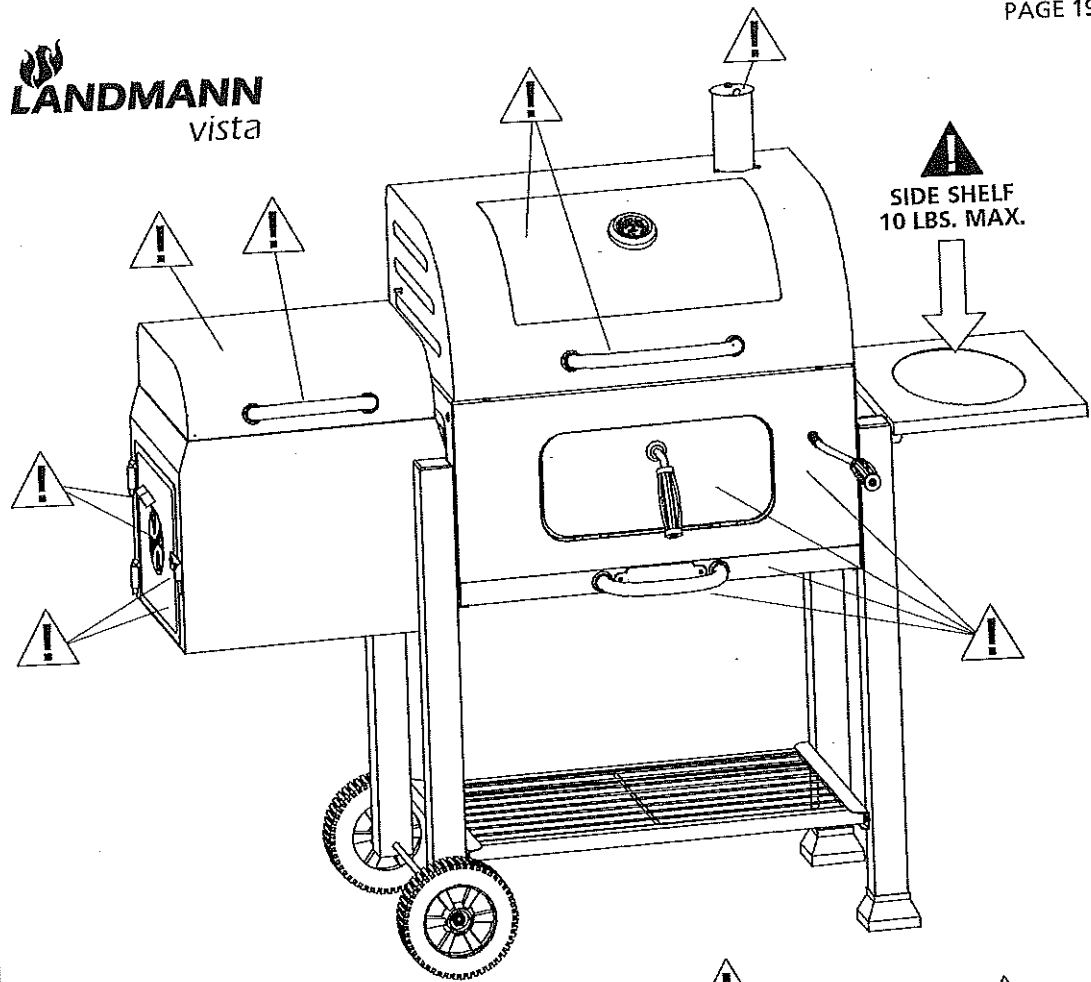

⚠ HOT SURFACES DURING USE! HANDLES BECOME WARM TO HOT WITH EXTENDED USE.

⚠ DO NOT STORE LIGHT FLUID OR OTHER FLAMMABLE LIQUID OR MATERIALS ON THE BOTTOM SHELF.

Landmann® Limited
Distributed by Landmann
Fairburn, GA 30213
www.landmann-usa.com
Made in China
© 2016 Landmann® USA



LIMITED WARRANTY

Landmann USA ("Landmann") warrants that this product shall be free of defects in material and workmanship to the original purchaser for 90 days. This limited warranty is made exclusively to the original customer presenting proof of purchase. This warranty is limited to non-commercial residential use only. Any returned goods must be shipped prepaid. The ash tray is specifically excluded from this warranty, as cleaning and maintaining is vital to its life, lining with aluminum foil will help prolong the use of the ash tray over time.

This warranty does not cover normal wear of parts or damage resulting from any of the following: negligence, abuse, misuse, alteration, improper installation, improper maintenance or failure to perform normal maintenance, or any use contrary to operating instructions. Furthermore, Landmann does not warrant in any way the paint finish of the product or cover damage or deterioration due to any normal or severe weather conditions or to any chemical exposure. These warranties do not cover surface scratches or heat damage, which is considered to be normal wear. These warranties exclude liability for any indirect, incidental consequential damages or loss of property of any nature.

Do not return product or any parts to the store or ship to the manufacturer without written authorization.

Contact Customer Service at: 1-877-3GRILLS (1-877-347-4557) or grills@landmann-usa.com. Any returned products or parts must be returned postage prepaid.

These warranties are limited to non-commercial residential use only.

Product repair or replacement as provided under this warranty is your exclusive remedy. Landmann shall not be liable for any incidental or consequential damages or breach of any express or implied warranty on this product or any part thereof, except to the extent prohibited by applicable law. Some states do not allow the exclusion or limitation of incidental or consequential damages, or allow limitation on how long an implied warranty lasts, therefore, the above limitation or exclusion may not apply to you. This warranty gives you specific legal rights, and you may also have other rights, which vary, from state to state.