

Outdoor Gourmet®

Assembly Instructions & User's Manual

6-Burner Gas Grill

Model number: GR2205720-OG-00

Ref. style: FSOGBG1108

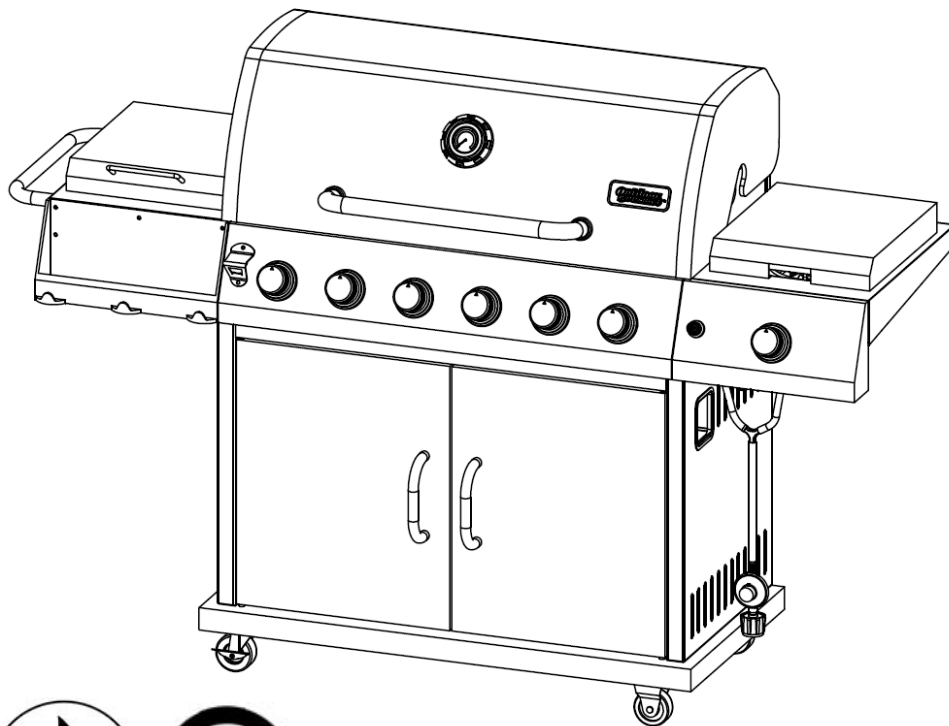

Please keep this instruction manual for future reference

Customer Service: 1-888-922-2336

7:00 am to 12:00 am CST (daily)

Live Chat at: www.academy.com

Email: customerservice@academy.com

-----OR-----

**Customer Service: 1-888-837-1380, 10:00am to 7:00pm, Monday thru Friday,
CST**

(Made in China)

Table of Contents

Warnings	2–7
Tools Required	7
Product Diagram	8
Parts List	9–13
Hardware List	14–15
Replacement Part List	16–17
Assembly Instructions	18–33
Leak Test	34–35
Lighting Instructions	36–38
Care and Maintenance	39–41
Trouble Shooting	42
Warranty Information	43

Note: Before beginning assembly of product, make sure all parts are present. Compare parts with package content list and hardware contents. If any part is missing or damaged do not attempt to assemble the unit. Contact customer service for replacement parts.

Warnings

SAFETY LABELS

 **DANGER:** Indicates an imminent hazardous situation which if not avoided will result in death or serious injury.

 **WARNING:** Be alert to the possibility of serious bodily injury if the instructions are not followed. Be sure to read and carefully follow all of the messages.

 **CAUTION:** Indicates a potentially hazardous situation, which, if not avoided, may result in minor or moderate injury.



Warnings

This instruction manual contains important information necessary for the proper assembly and safe use of this product. Read and follow all warnings and instructions before assembling and using this product. Failure to follow these instructions and warnings could result in damage to the product or injury to the user. Keep this instruction manual for future reference.



DANGER



If you smell gas:

1. Shut off gas to the appliance.
2. Extinguish any open flame.
3. Open lid.
4. If odor continues, keep away from the appliance and immediately call your gas supplier or fire department.

Failure to follow these instructions could result in fire or explosion which could cause property damage, personal injury or death.



WARNING



1. Do not store or use gasoline or other flammable liquids or vapors in the vicinity of this or any other appliance.
2. An LP cylinder not connected for use shall not be stored in the vicinity of this or any other appliance.

Warnings



DANGER



- (a) Do not store a spare LP-gas cylinder under or near this appliance;
- (b) Never fill the cylinder beyond 80 percent full;
- (c) If the information in (a) and (b) is not followed exactly, a fire causing death or serious injury may occur.



WARNING



- This outdoor cooking gas appliance shall be used only outdoors and shall not be used in a building, garage or any other enclosed area.
- This outdoor cooking gas appliance is not intended to be installed in or on boats. This appliance is not intended to be installed in or on recreational vehicles.
- Use your grill OUTDOORS in a well ventilated space away from dwellings or other buildings to prevent dangers associated with gas accumulation and toxic vapors. The grill should be situated at least 60 inches (152.4 cm) from buildings. Not adhering to these clearances will prevent proper ventilation and may increase the risk of a fire and/or property damage, which could also result in personal injury.
- Maintain a minimum clearance of 60 inches (152.4 cm) between all sides of grill, deck railings, walls or other combustible material. DO NOT use grill under overhead combustible construction.
- **DO NOT** obstruct the flow of combustion/ventilation air.
- **DO NOT** leave the grill unattended while in use.
- **DO NOT** use while under the influence of drugs or alcohol.
- Keep the fuel supply hose away from heated surfaces.
- **DO NOT** put grill in storage or move it after use. Allow grill to cool to touch before moving/storing. Failure to do so could result in fire resulting in property damage, personal injury or death.
- The appliance is for household use only. **DO NOT** use this grill for other than its intended purpose.
- Never use natural gas in a unit designed for liquid propane gas.
- Never use charcoal or wood briquettes in a gas grill. Flavoring chips must be contained in a metal smoking box to contain ash and prevent fires.
- Leak test must be conducted prior to each use.

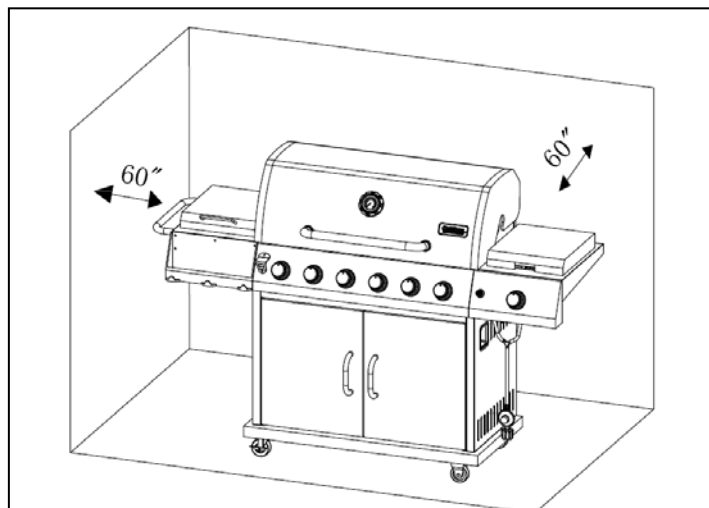

Maintain a minimum clearance of 60 inches from combustible material.

Warnings

- Keep a fire extinguisher on hand intended for use with gas products. Refer to your local authority to determine proper size and type.
- Keep the outdoor cooking gas appliance area clear and free from combustible materials, gasoline and other flammable vapors and liquids.
- Grill is hot when in use. To avoid burns:
 - **DO NOT** attempt to move the grill.
 - Lock the wheels so the unit does not accidentally move.
 - Wear protective gloves or oven mitts.
 - **DO NOT** touch any hot grill surfaces.

DO NOT wear loose clothing or allow hair to come in contact with grill.

USE OF LP GAS CYLINDER AND INSTALLATION

BEFORE INSTALLING:

The installation must conform with local codes or, in the absence of local codes, with either the *National Fuel Gas Code, ANSI Z223.1/NFPA 54, Natural Gas and Propane Installation Code, CSA B149.1, or Propane Storage and Handling Code, B149.2* or the *Standard for Recreational Vehicles, ANSI A 119.2/NFPA 1192, and CSA Z240 RV Series, Recreational Vehicle Code*, as applicable.

BEFORE EVERY USAGE:

Be sure to inspect the hose for leaks, cuts, wear, abrasion, or damage of any sort before using this appliance. If any damage is apparent, the hose must be replaced with a replacement hose specified by the manufacturer before it is put in use.

LP GAS CYLINDER:

The LP (liquid propane) cylinder specifically designed to be used with this unit **MUST** have a 20 lb. (9.1kg) capacity with a Q.C.C. Type 1 cylinder valve and an overfilling protection device (OPD). Only use LP cylinders with this type of valve.

LP tank valve must have:

- Purchase LP tanks only with these required measurements: 12" (30.5cm) (diameter) x 18" (45.7cm) (tall) with 20lb. (9kg). Capacity maximum.
- Q.C.C. Type 1 outlet compatible with regulator or appliance.
- Safety relief valve.
- UL listed Overfill Protection Device (OPD). This OPD safety feature is identified by a unique triangular hand wheel. Use only tanks equipped with this type of valve.
- LP tank must be arranged for vapor withdrawal.
The LP cylinder must be constructed and marked in accordance with the Specifications for LP-Gas Cylinders of the U.S. Department of Transportation (D.O.T.) or the National Standard of Canada CAN/CSA – B339, Cylinder, Spheres and Tubes for Transportation of Dangerous Goods; and Commission of Dangerous Goods; as applicable.
- The LP cylinder must include a collar to protect the cylinder valve.

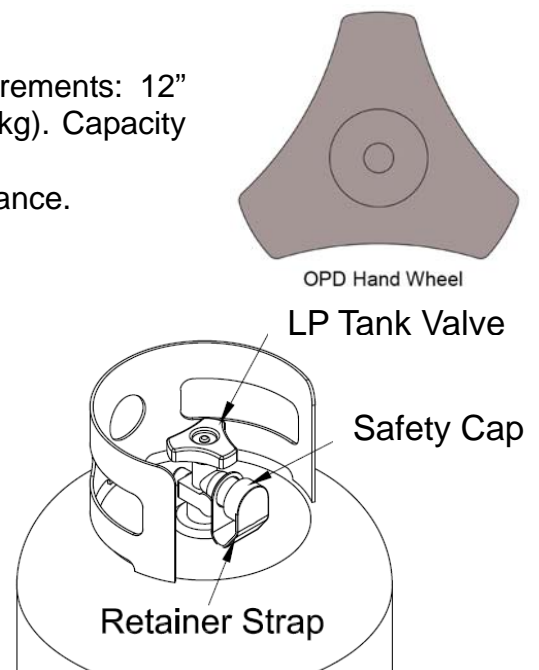

Warnings

- If the outdoor cooking gas appliance is not in use, the gas must be turned off at the supply cylinder(s).
- The LP cylinder must be stored outdoors out of the reach of children and **MUST NOT** be stored in a building, garage, shed, breezeway, or any other enclosed area.
- Storage of an outdoor cooking gas appliance indoors is permissible **ONLY** if the cylinder is disconnected and removed from the outdoor cooking gas appliance.
- The cylinder should **ALWAYS** be put in an upright position.



DANGER



- **DO NOT** connect this grill to an existing #510 POL cylinder valve with Left hand threads. The Type 1 valve can be identified with the large external threads on the valve outlet.
- **DO NOT** connect to a propane cylinder exceeding its capacity.
- **DO NOT** connect to a cylinder that uses any other type of valve connection device.
- Never store a spare LP gas cylinder under or near your grill. This could cause pressure to be expelled through the vapor relief valve resulting in fire, explosion or severe personal injury including death.
- Keep the ventilation opening(s) of the LP gas cylinder enclosure free and clear from obstructions and debris.
- **DO NOT** insert any foreign objects into the valve outlet. Damage to the valve outlet could result. A valve outlet can cause a leak, possibly resulting in explosions, fire, severe bodily harm or death.



WARNING



FOR FILLING THE LP GAS CYLINDER

- Allow only qualified LP gas dealers to properly fill or repair your LP cylinder.
- **DO NOT** allow the cylinder to be filled beyond 80% capacity. Over-filled tanks can create a dangerous condition. Over-filled tanks can build-up pressure and cause the relief valve to expel propane gas vapors. The vapor is combustible and if it comes in contact with a spark source or flame an explosion causing severe burns, bodily harm or death could occur.
- Always use a safety cap when grill is not connected to a cylinder.
- If you exchange a cylinder with a qualified exchange program, be sure the cylinder has a Type 1 valve and an over-filling prevention device (OPD).

Warnings

INSTALLING GAS CYLINDER

1. Check that the cylinder valve is closed by turning the knob clockwise.
2. Place the cylinder into tank fixture on the cart base properly. Locate the cylinder so that the valve opening faces the right side burner and verify that the hose is not kinked/damaged.
3. Attach or detach regulator to LP cylinder only when cylinder is rested on the cart base properly.

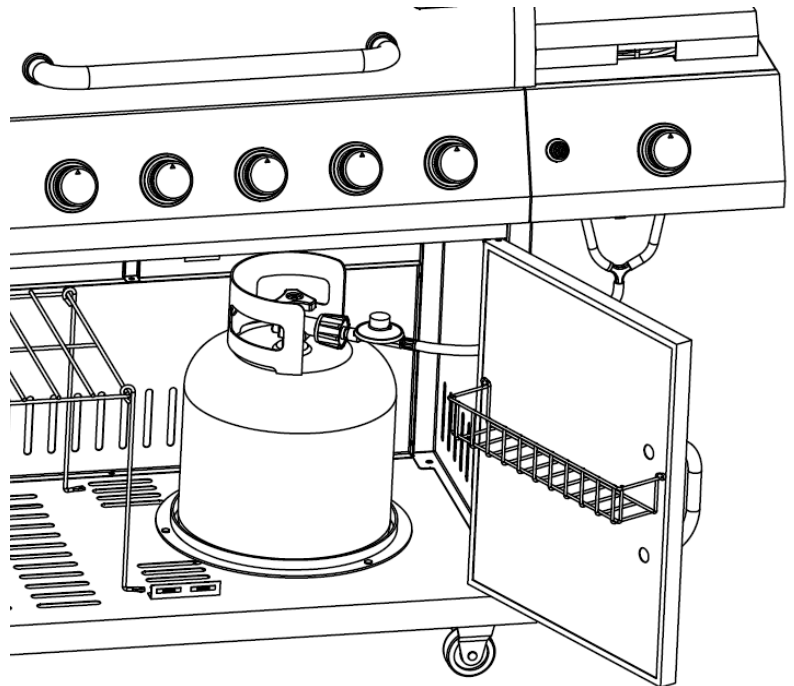

WARNING: Keep the fuel supply hose away from any heated surfaces.

CONNECTION PROCEDURES

1. Make sure the tank valve is closed (turn valve clockwise until tight).
2. Check tank valve to insure it has proper external male threads.
3. Make sure all burner valves are turned **OFF**.
4. Inspect valve connections, port, and regulator assembly. Look for any damage or debris. Remove any debris. Inspect hose for damage. Never attempt to use damaged or obstructed equipment. See local L.P gas dealer for repair.
5. When connecting regulator assembly to the valve, hand tighten the quick coupling nut clockwise to a complete stop. Do not use a wrench to tighten. Use of a wrench may damage the quick coupling nut and result in a hazardous condition.
6. Open the tank valve fully (counterclockwise). Use a soapy water solution to check all connections for leaks before attempting to light the grill (see P.34-35). If a leak is found, turn the tank valve off and do not use the grill until a local LP gas dealer can make repairs.

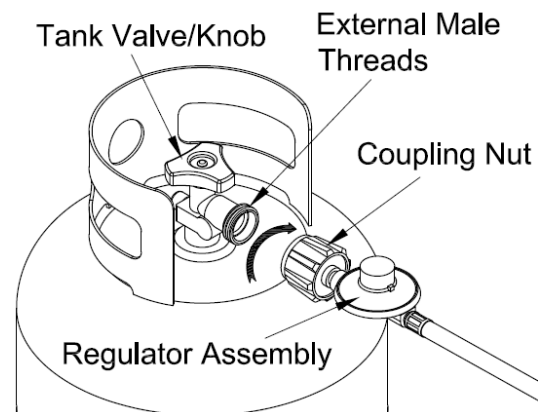

Warnings

TO DISCONNECT LP CYLINDER:

1. Turn the burner valves off.
2. Turn the tank valve off fully (turn clockwise to stop).
3. Detach the regulator assembly from the tank valve by turning the quick coupling nut counterclockwise.





CAUTION



- When installing LP cylinders the pressure regulator and hose supplied by the manufacturer **MUST** be used with the appropriate cylinder. Replacement regulators and hoses need to be specified by the manufacturer of this appliance.
- Place dust cap on cylinder valve outlet whenever cylinder is not in use. Only install the type of dust cap on the cylinder valve outlet that is provided with the cylinder. Other types of caps or plugs may result in leakage of propane.



Tools Required

1	Phillips screwdriver (not included)	
2	Adjustable wrench (not included)	

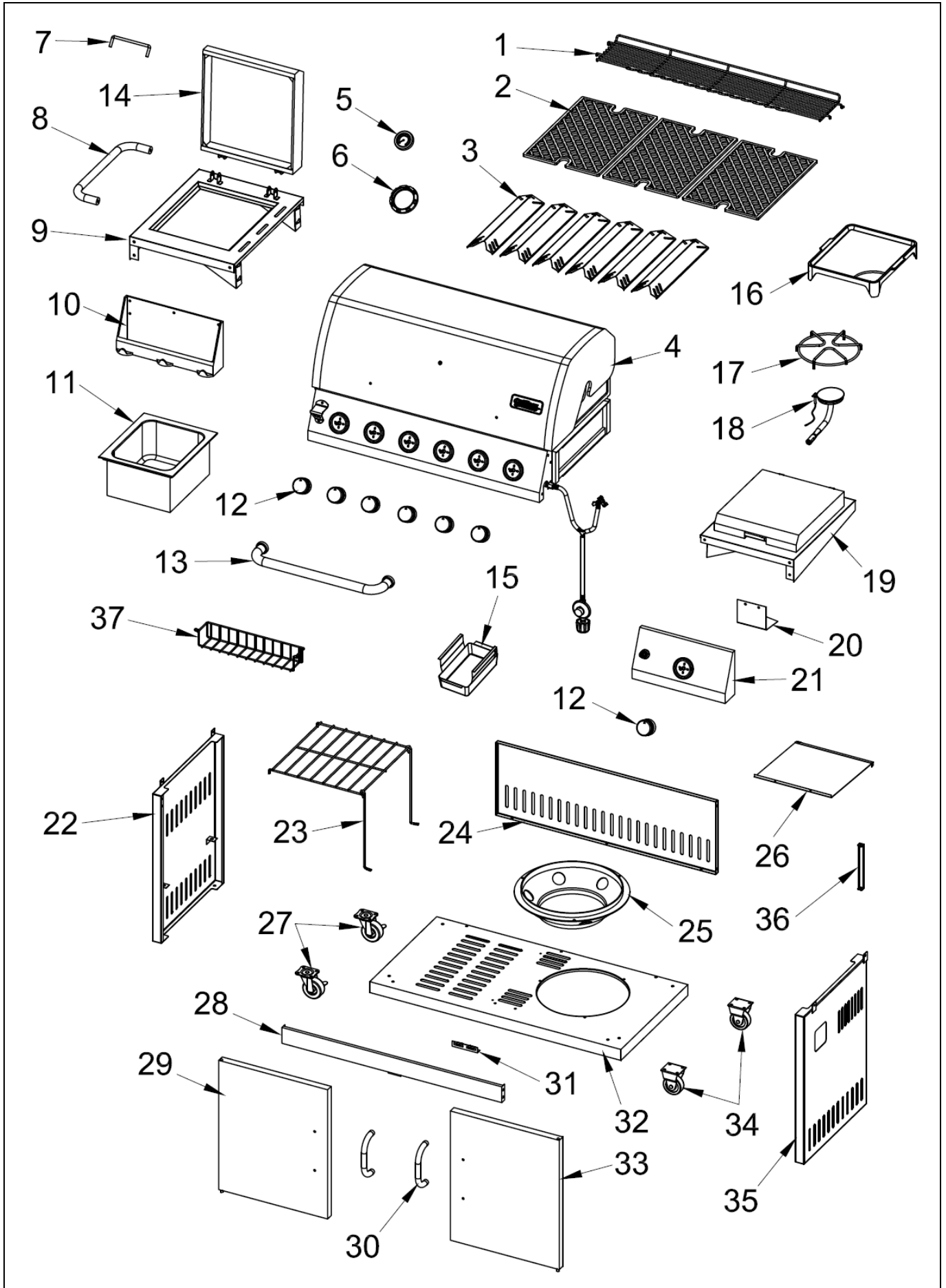
Product Diagram



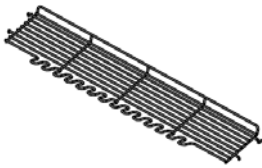
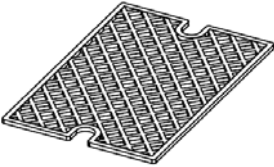
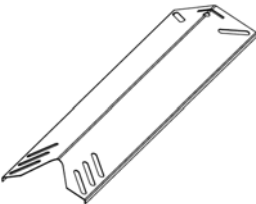
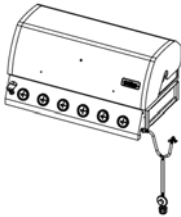

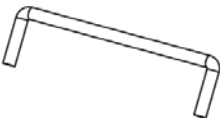
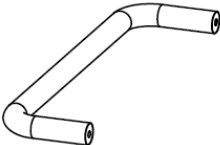
Parts List

1	Warming Rack		1 pc
2	Cooking Grate		3 pcs
3	Flame Tamer		6 pcs
4	Grill Body Assembly		1 pc
5	Thermometer		1 pc
6	Thermometer Bezel		1 pc
7	Side Table Lid Handle		1 pc
8	Side Table Handle		1 pc

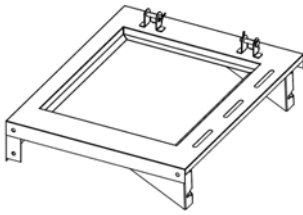
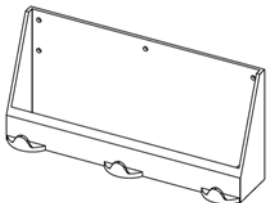
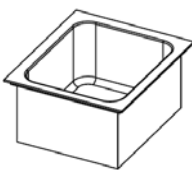
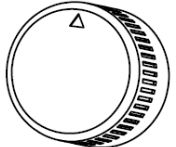
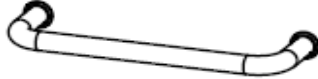
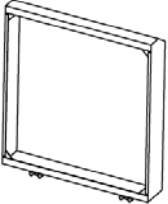
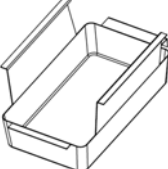
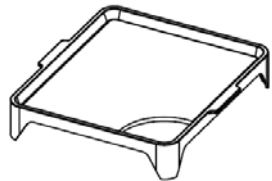

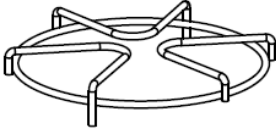
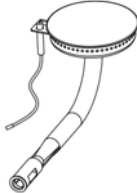
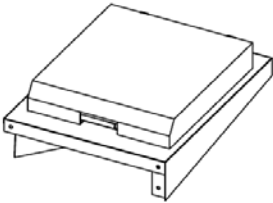
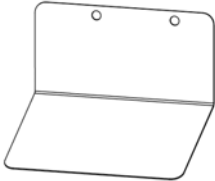
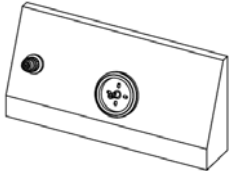
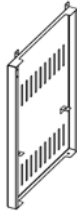

Parts List

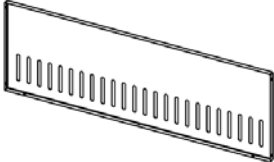
9	Left Side Table Frame		1 pc
10	Left Side Condiment Tray		1 pc
11	Ice Bin		1 pc
12	Control Knob / Side Burner Control Knob		7 pcs
13	Grill Lid Handle Assembly		1 pc
14	Side Table Lid		1 pc
15	Grease Cup		1 pc
16	Cast Iron Griddle		1 pc

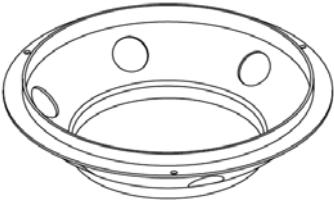
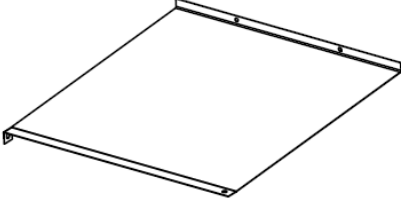

Parts List

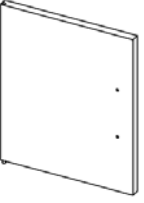
17	Side Burner Grate		1 pc
18	Side Burner Assembly		1 pc
19	Side Burner Frame Assembly		1 pc
20	Side Burner Heat Shield		1 pc
21	Side Burner Control Panel Assembly		1 pc
22	Left Cart Panel		1 pc
23	Cart Rack		1 pc
24	Rear Cart Panel		1 pc

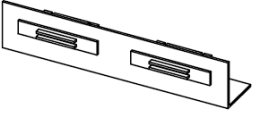
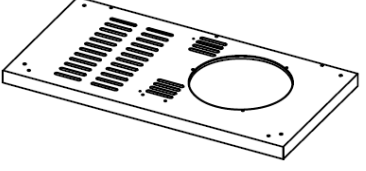
Parts List

25	Tank Fixture		1 pc
26	Tank Heat Shield		1 pc
27	Locking Caster		2 pcs
28	Front Cart Supporting Beam		1 pc
29	Left Door		1 pc
30	Door Handle		2 pcs
31	Magnet Bracket		1 pc
32	Cart Base		1 pc

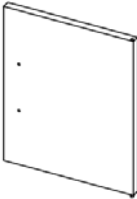
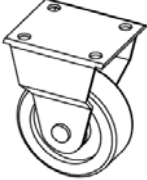
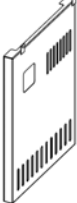

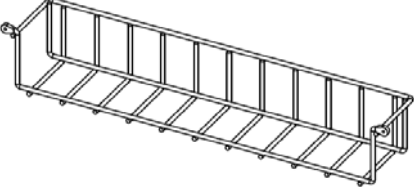

Parts List

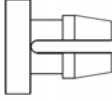
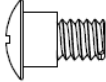
33	Right Door		1 pc
34	Unlocking Caster		2 pcs
35	Right Cart Panel Assembly		1 pc
36	Tank Heat Shield Supporting Bar		1 pc
37	Accessory Rack		1 pc

Hardware List

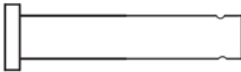
A	M6x15mm Bolt		16 pcs
B	M6x10mm Bolt		22 pcs
C	Plastic Rivet		3 pcs
D	M6 Step Bolt		2 pcs
E	M6x12mm Bolt		22 pcs
F	M4x10mm Bolt		15 pcs
G	M4 Self-Tapping Screw		2 pcs
H	M6x16mm Bolt (Silver)		2 pcs
I	M4 Washer		2 pcs
J	M5x10mm Bolt		2 pcs
K	M6 Nut		4 pcs
L	LR6/AA Battery		1 pc

Hardware List

M	Hinge Pin		2 pcs
N	Cotter Pin		2 pcs
O	M6 Washer		2 pcs
P	Thermometer Washer		1 pc
Q	Thermometer Nut		1 pc

Note: Hardware H, I, J, M, N, O, P and Q have been pre-attached on the related components.

For Bolt E, 4 pcs are stored in the hardware pack, and 18 pcs have been pre-attached on the related components.

For Bolt F, 11 pcs are stored in the hardware pack, and 4 pcs have been pre-attached on the related components.

Replacement Part List (I)

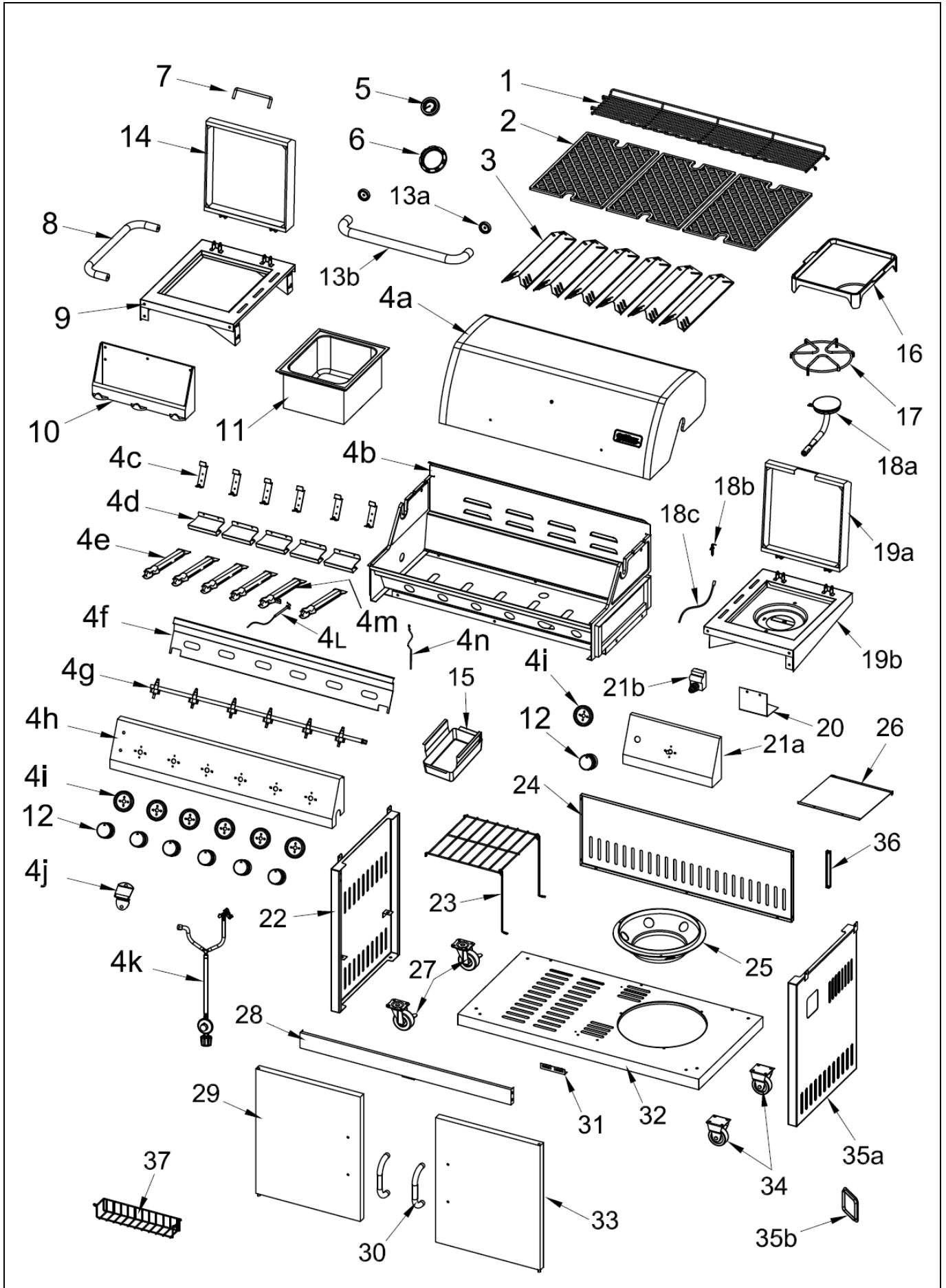

Replacement Part List (II)

Part Number	Part Name	Part Number	Part Name
1	Warming Rack	2	Cooking Grate
3	Flame Tamer	4	Grill Body Assembly
4a	Grill Body – Lid	4b	Grill Body – Fire Box
4c	Grill Body – Burner Support	4d	Grill Body – Carry Over
4e	Grill Body – Burner	4f	Grill Body – Heat Shield
4g	Grill Body – Valve & Manifold Assembly	4h	Grill Body – Control Panel
4i	Grill Body – Control Knob Bezel	4j	Grill Body – Bottle Opener
4k	Grill Body – Hose & Regulator Assembly	4L	Grill Body – Ignition Electrode & Wire
4m	Grill Body – Ignition Burner	4n	Grill Body – Match Holder
5	Thermometer	6	Thermometer Bezel
7	Side Table Lid Handle	8	Side Table Handle
9	Left Side Table Frame	10	Left Side Condiment Tray
11	Ice Bin	12	Control Knob / Side Burner Control Knob
13	Grill Lid Handle Assembly	13a	Grill Lid Handle
13b	Grill Lid Handle Bezel	14	Side Table Lid
15	Grease Cup	16	Cast Iron Griddle
17	Side Burner Grate	18	Side Burner Assembly
18a	Side Burner	18b	Ignition Electrode
18c	Ignition Wire	19	Side Burner Frame Assembly
19a	Side Burner Lid	19b	Side Burner Frame
20	Side Burner Heat Shield	21	Side Burner Control Panel Assembly
21a	Side Burner Control Panel	21b	Igniter
22	Left Cart Panel	23	Cart Rack
24	Rear Cart Panel	25	Tank Fixture
26	Tank Heat Shield	27	Locking Caster
28	Front Cart Supporting Beam	29	Left Door
30	Door Handle	31	Magnet Bracket
32	Cart Base	33	Right Door
34	Unlocking Caster	35	Right Cart Panel Assembly
35a	Right Cart Panel	35b	Plastic Ring
36	Tank Heat Shield Supporting Bar	37	Accessory Rack

Assembly Instructions

Step 1.

Attach the **Locking Caster (27)** and **Unlocking Caster (34)** to the **Cart Base (32)** by using 16 pcs **M6X15 Bolts (A)**.

Hardware:

#A – 16 pcs

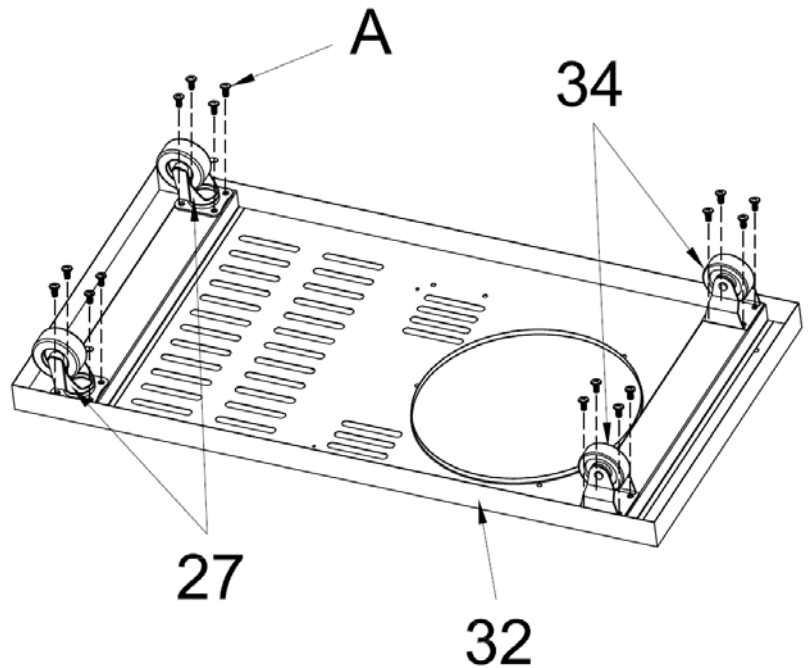

Step 2.

Lock the 2 locking casters to prevent the unit moving by stepping the pad downwards. Attach the **Left Cart Panel (22)** and **Right Cart Panel Assembly (35)** to the cart base assembly by using 4 pcs **M6X10 Bolts (B)**.

Hardware:

#B – 4 pcs

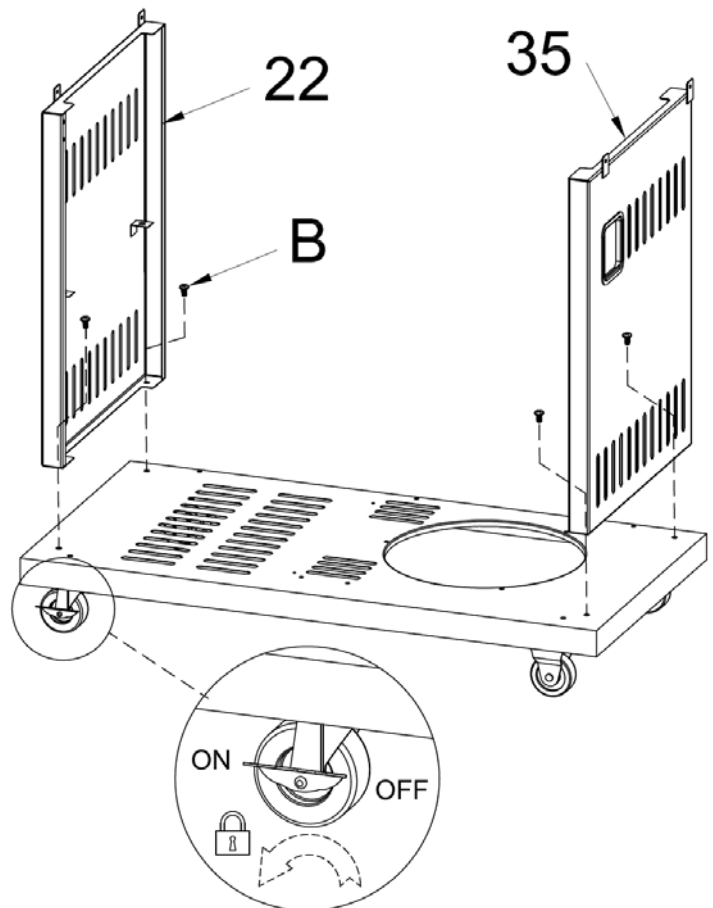

Assembly Instructions

Step 3.

Attach the **Rear Cart Panel (24)** to the cart assembly by using 7 pcs **M6X10 Bolts (B)**.

Hardware:

#B – 7 pcs

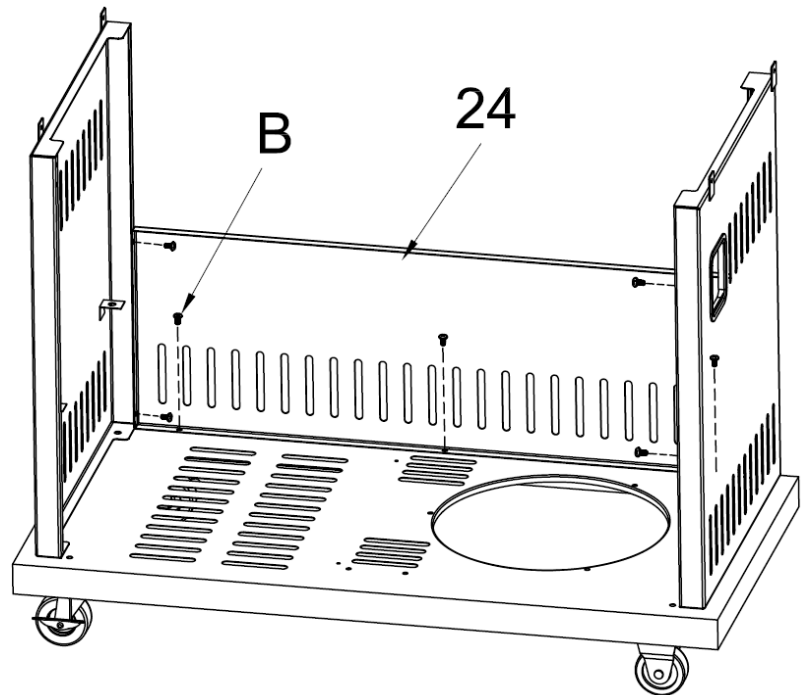

Step 4.

Attach the **Front Cart Supporting Beam (28)** to the cart assembly by using 4 pcs **M6X10 Bolts (B)**.

Hardware:

#B – 4 pcs

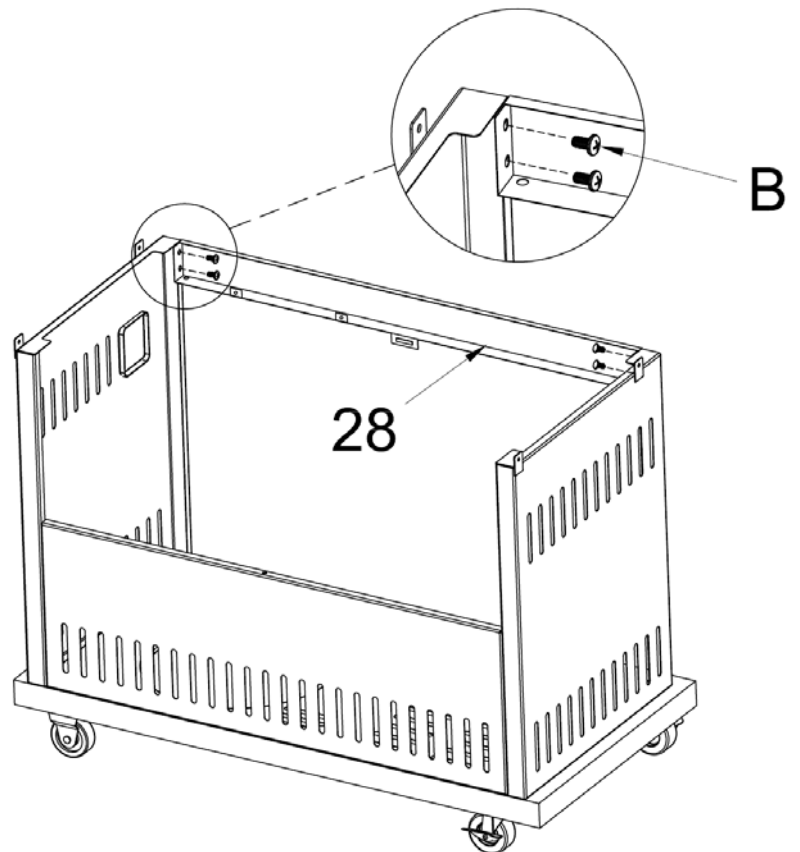

Assembly Instructions

Step 5.

Attach the **Tank Fixture (25)** to the cart assembly by using 3 pcs **Plastic Rivet (C)**.

Hardware:

#C – 3 pcs

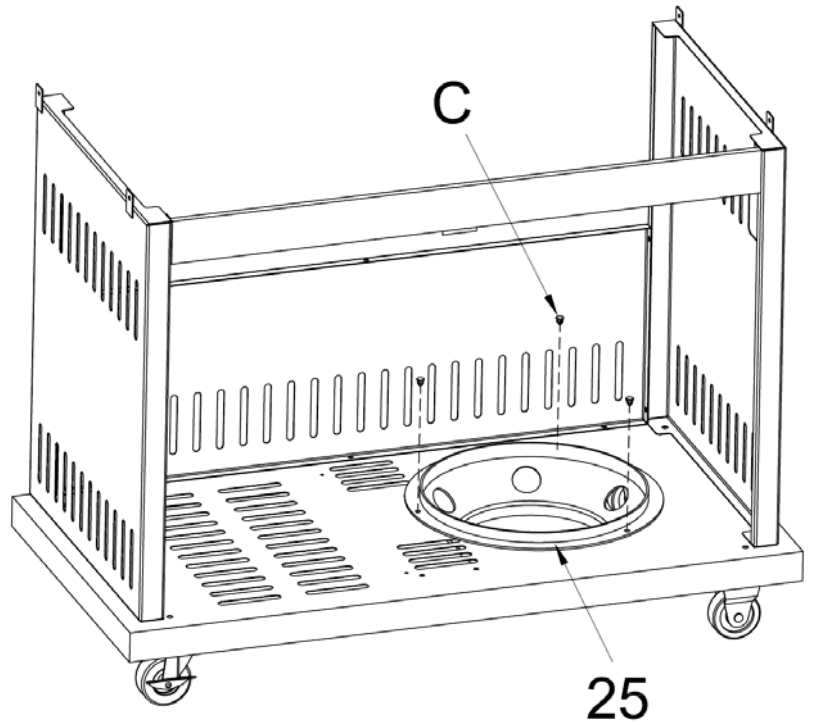

Step 6.

Attach the **Left Door (29)** and **Right Door (33)** to the cart assembly by using 2 pcs **M6 Step Bolts (D)**.

Remember to insert the bottom door pin into the hole at the cart assembly first then use **M6 Step Bolts (D)** to secure the door.

Hardware:

#D – 2 pcs

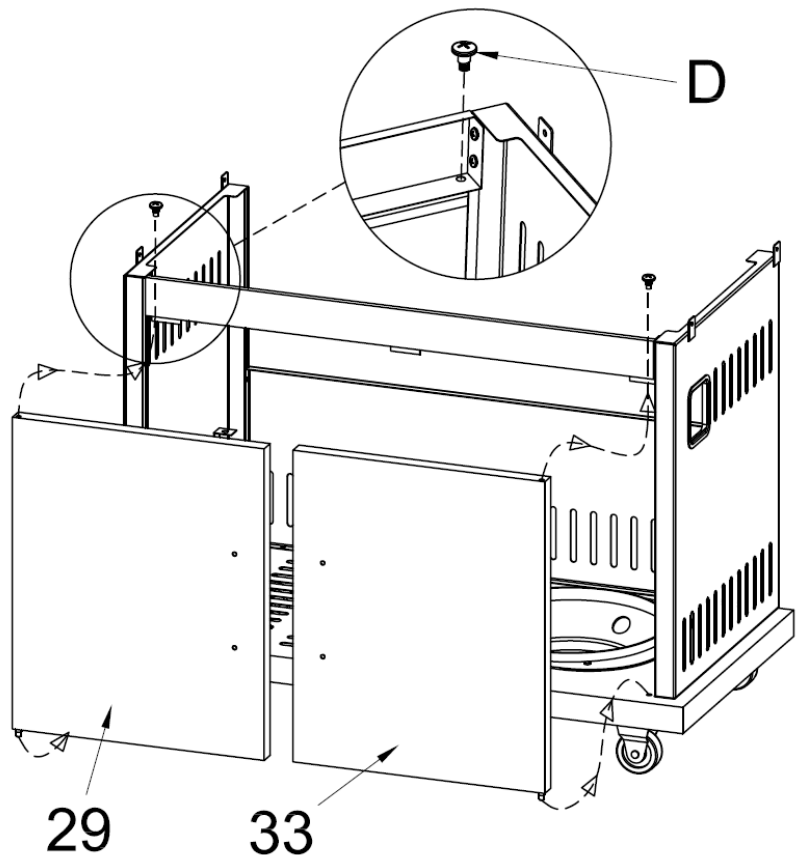

Assembly Instructions

Step 7.

Attach the **Magnet Bracket (31)** to the cart assembly by using 2 pcs **M4X10 Bolts (F)**.

Hardware:

#F – 2 pcs

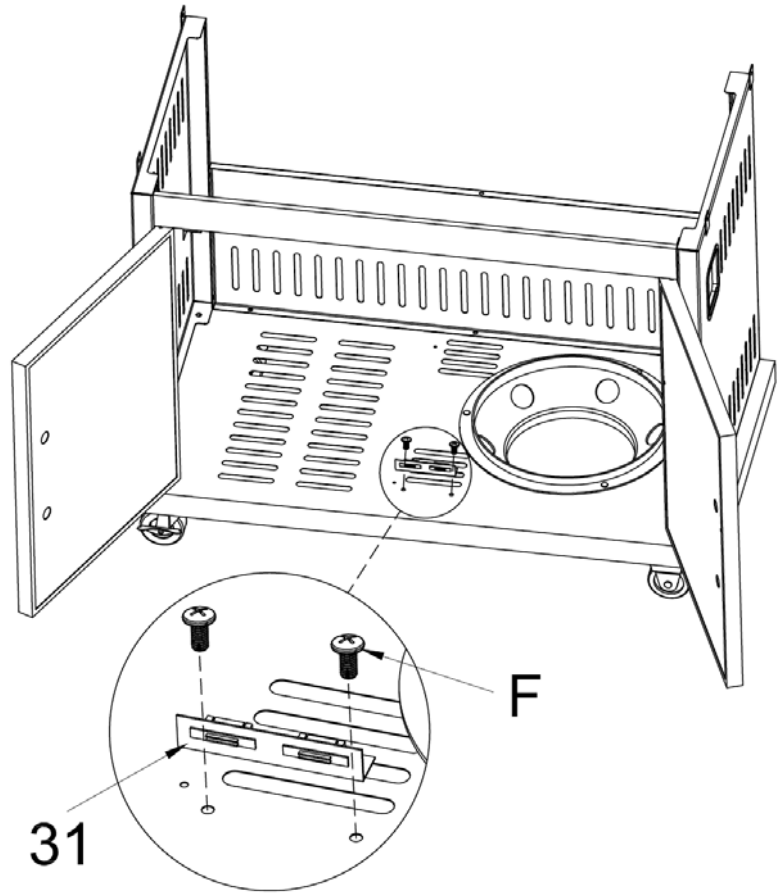

Step 8.

Remove 4 pcs pre-attached **M6X12 Bolts (E)** from the **Door Handle (30)**.

Attach the door handles to the doors by using the removed bolts.

Hardware:

#E – 4 pcs

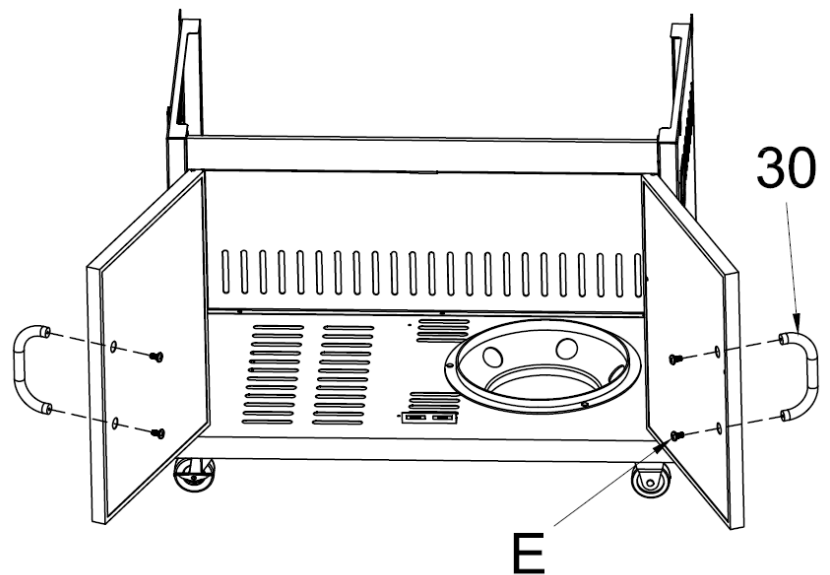

Assembly Instructions

Step 9.

Attach the **Cart Rack (23)** to the cart assembly by inserting the hooks at the top left side of the cart rack into the holding brackets at the left cart panel then using 2 pcs **M4X10 Bolts (F)** to secure the cart rack.

Hardware:
#F – 2 pcs

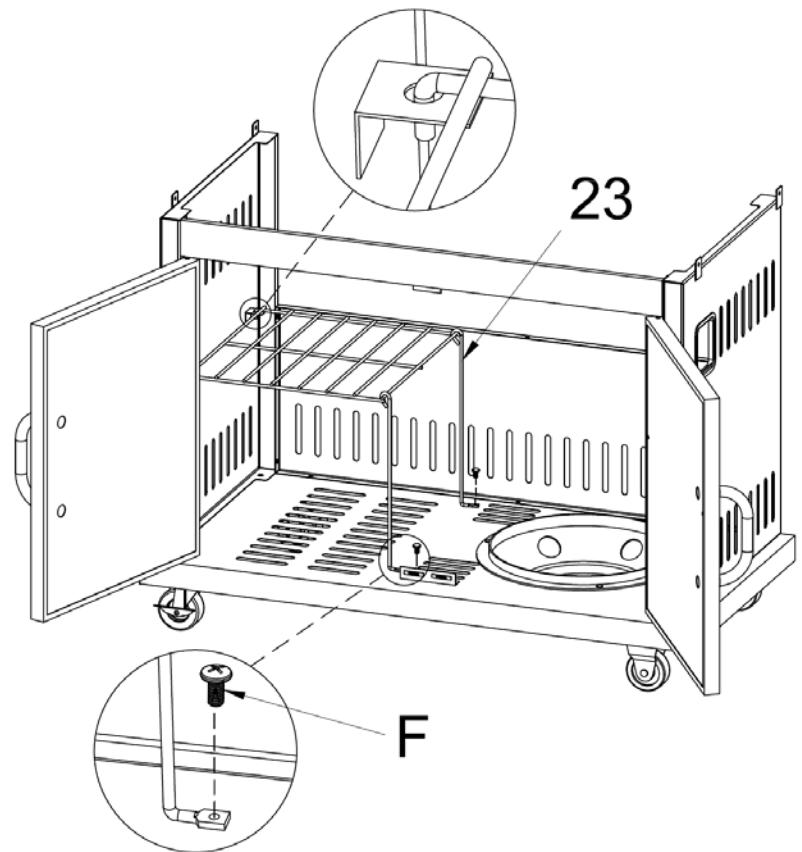

Step 10.

Attach the **Accessory Rack (37)** to the right door by using 2 pcs **M4X10 Bolts (F)**.

Hardware:
#F – 2 pcs

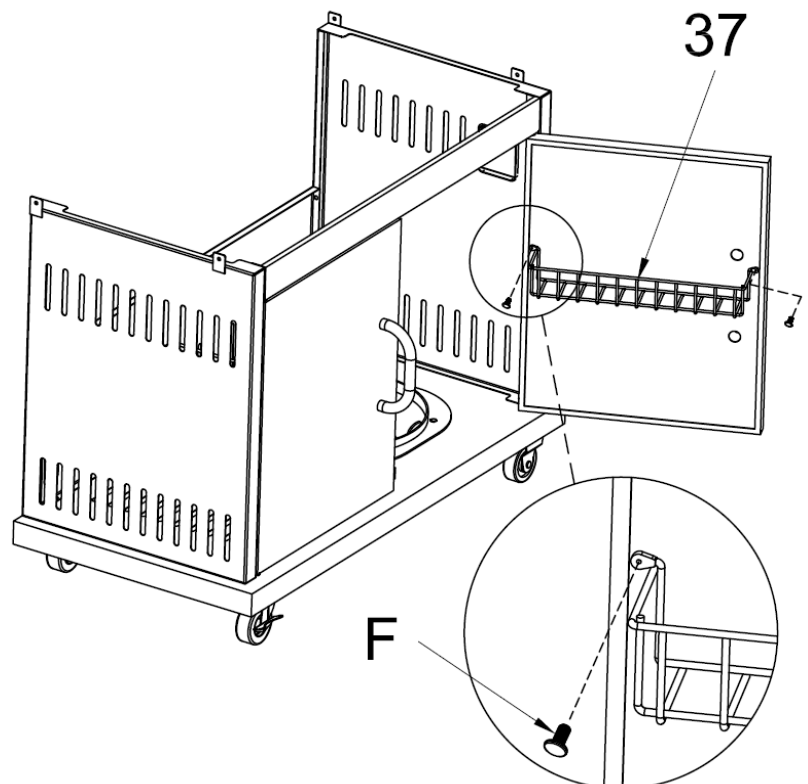

Assembly Instructions

Step 11.

Attach the **Tank Heat Shield (26)** to the cart assembly by using 1 pc **M4X10 Bolts (F)** and 2 pcs **M4X10 Self-tapping Screws (G)**. Then attach the **Tank Heat Shield Supporting Bar (36)** to the cart assembly and tank heat shield by using 2 pcs **M4X10 Bolts (F)**.

Hardware:
#F – 3 pcs
#G – 2 pcs

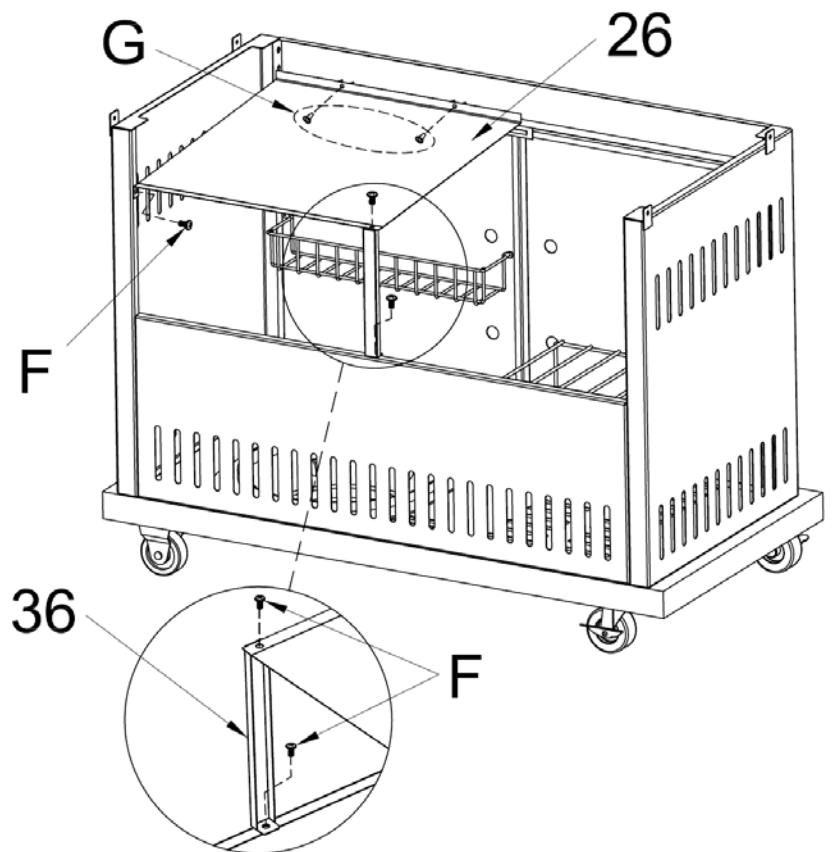

Step 12.

This step needs two people to complete! Put the **Grill Body Assembly (4)** carefully at the top of the cart assembly. Secure the part as shown with 4 pcs of **M6x10mm bolts (B)**. Be careful to support the grill body and cart assembly during this step.

Hardware:
#B – 4 pcs

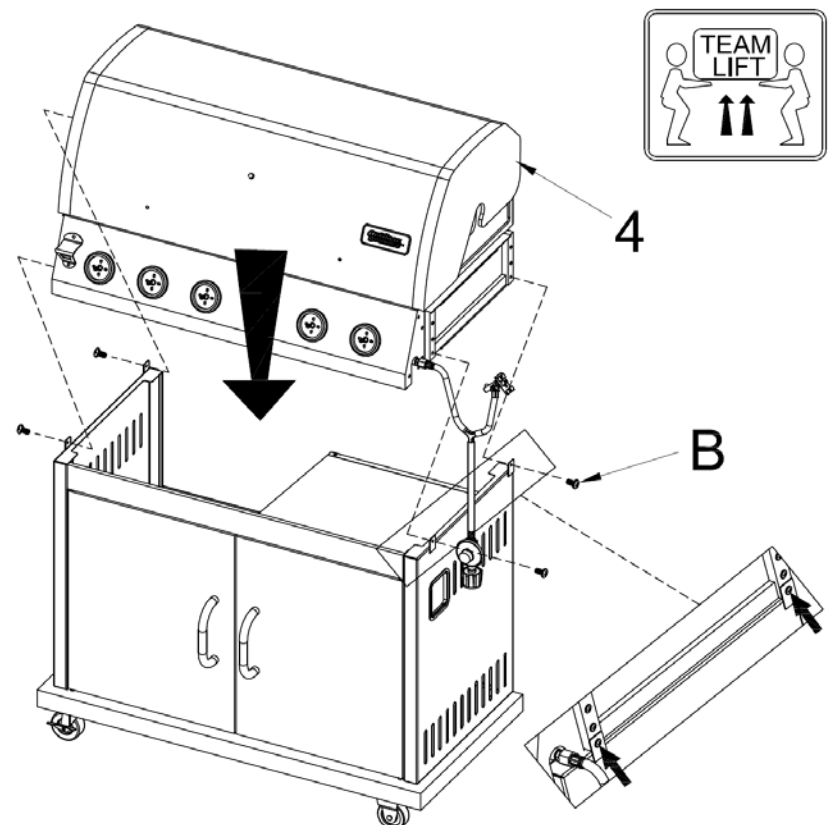

Assembly Instructions

Step 13.

Disassemble the **Handle Bezel (13a)** and **M6x16 bolts Silver (H)** from the **Grill Lid Handle Assembly (13)**. Attach the **Handle (13b)** and **Handle Bezel (13a)** to the lid by using 2 pcs **M6x16 bolts Silver (H)** as shown.

Hardware:
#H – 2 pcs

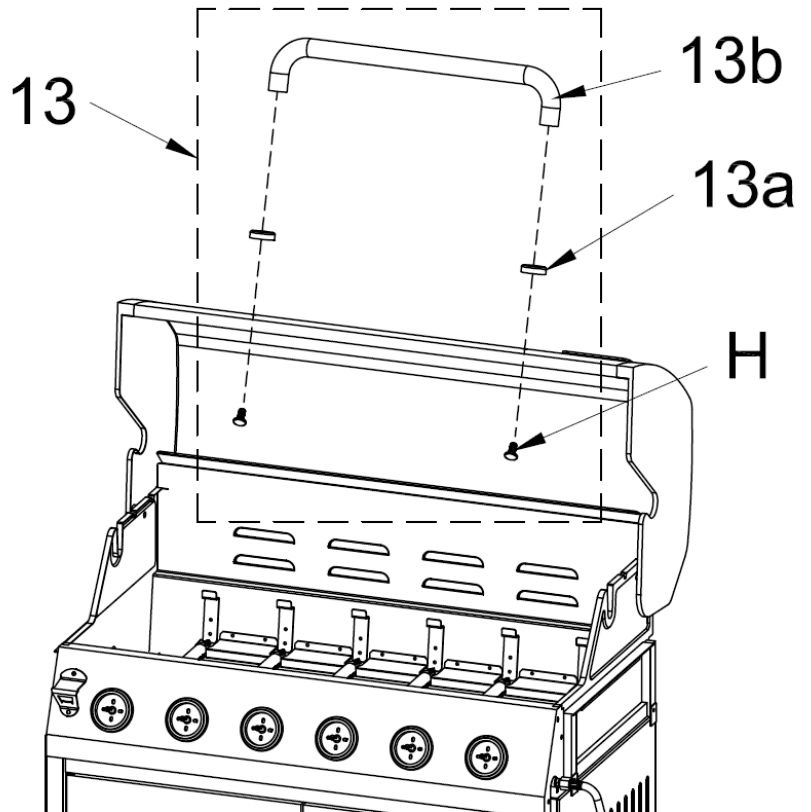

Step 14.

Disassemble the **Thermometer Nut (Q)** and **Thermometer Washer (P)** from the **Thermometer (5)** and **Thermometer Bezel (6)**. Attach the thermometer and the thermometer bezel to the grill lid. Align them through the hole on the lid and place the washer underneath the nut then tighten the nut as shown.

Hardware:
#P – 1 pc
#Q – 1 pc

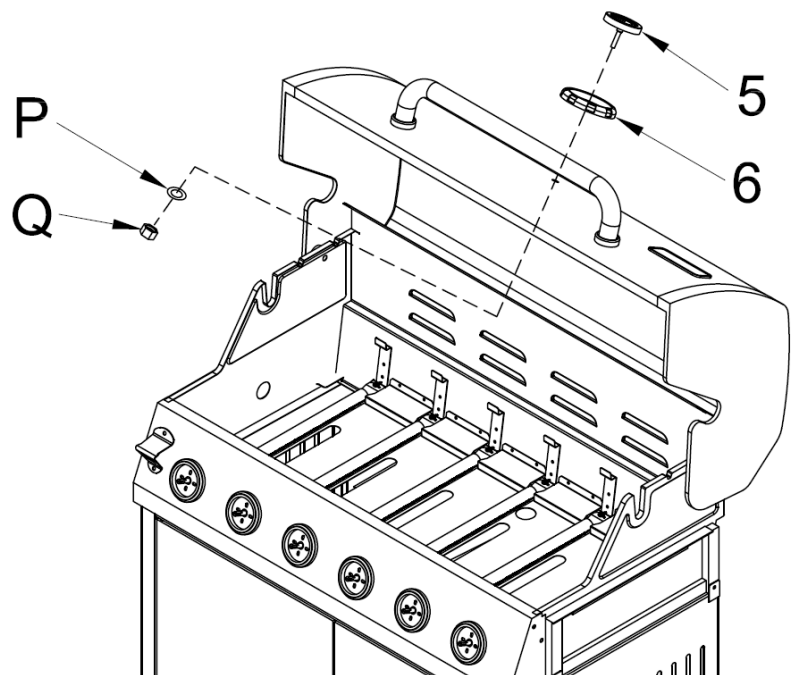

Assembly Instructions

Step 15.

Remove 2 pcs pre-attached **Hinge Pin (M)** and 2 pcs pre-attached **Cotter Pin (N)** from the **Left Side Table Frame (9)**

Attach the **Side Table Lid (14)** to the **Left Side Table Frame (9)** and secure them by using the removed hinge pins and cotter pins as shown.

Hardware:

#M – 2 pcs

#N – 2 pcs

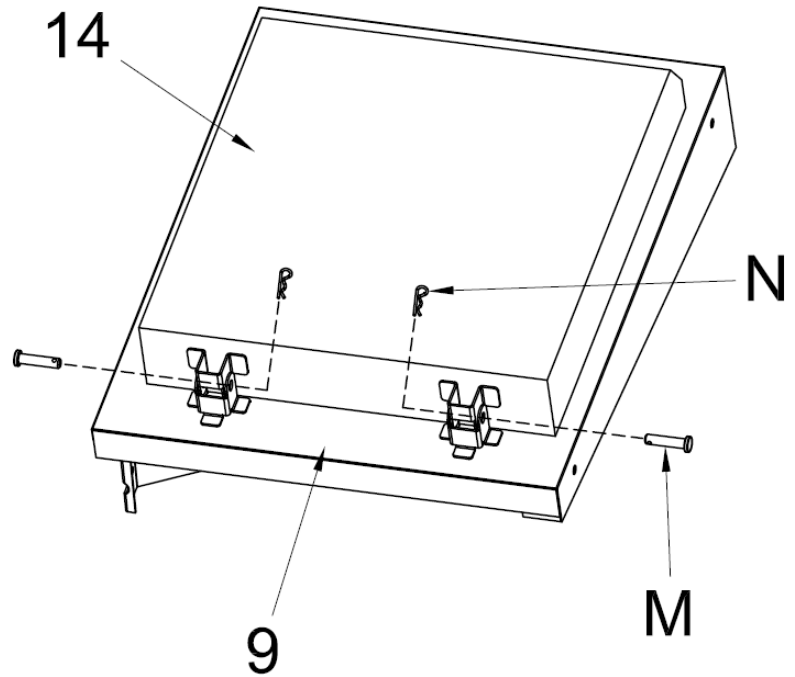

Step 16.

Attach the **Left Side Condiment Tray (10)** to the left side table assembly by using 4 pcs **M6x12 bolts (E)** and 4 pcs **M6 Nut (K)**.

Hardware:

#E – 4 pcs

#K – 4 pcs

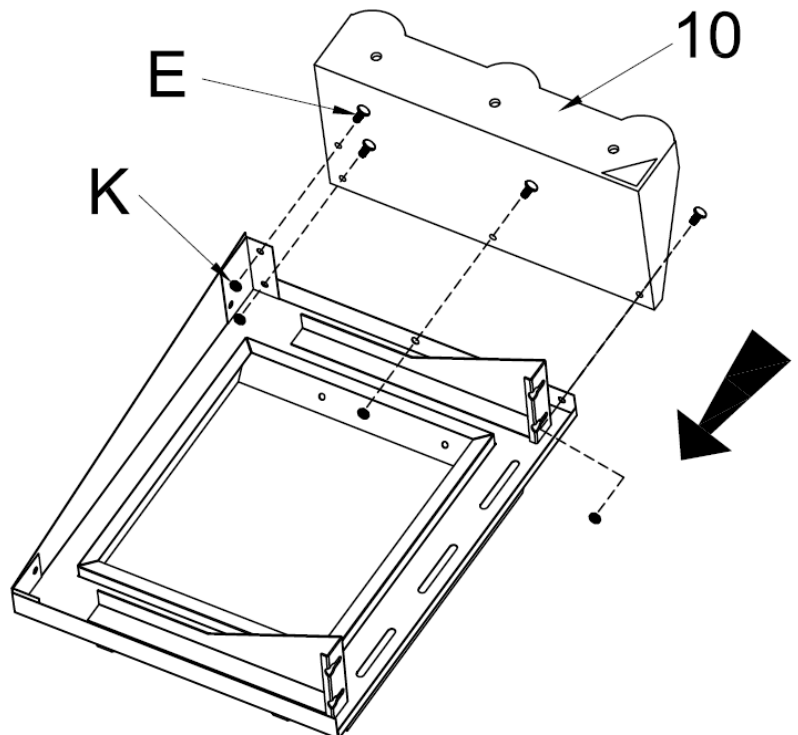

Assembly Instructions

Step 17.

Remove 2 pcs pre-attached **M6x12 bolts (E)** and 2 pcs **M6 Washers (O)** from the **Side Handle (8)**.

Attach the Side Table Handle to left side table assembly by using the removed bolts and washers.

Hardware:

#E – 2 pcs

#O – 2 pcs

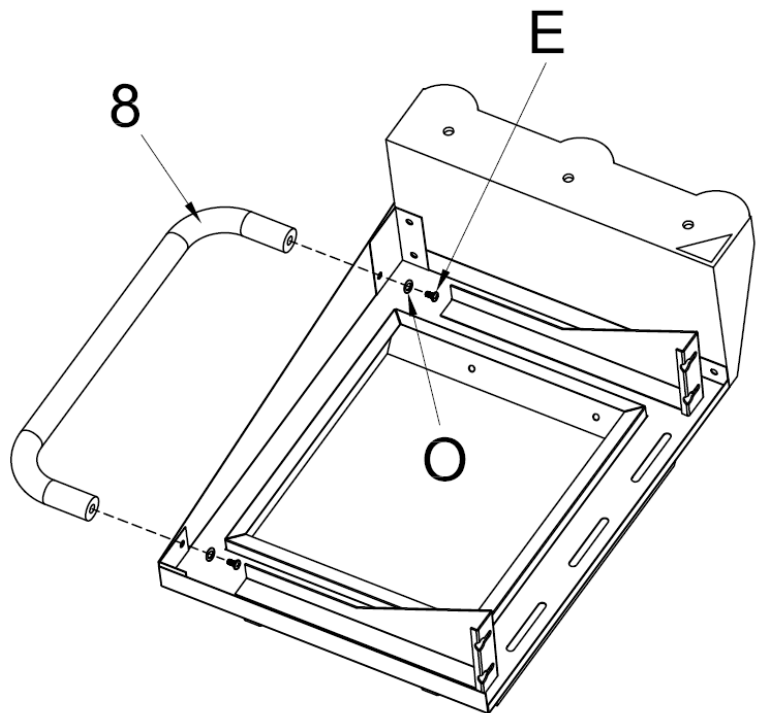

Step 18.

Remove 2 pcs pre-attached **M6x12mm bolts (E)** at the left side of the control panel. Loosen 4 pcs pre-attached bolts **M6x12 bolts (E)** on left side of the grill body and adjust to 3/16" clearance as shown. Position the holes on the left side table assembly through the bolts at grill body as shown. Push the left side table leftwards to lock it in place and tighten the bolts **M6x12 bolts (E)**. Then insert 2 pcs removed **M6x12mm bolts (E)** to the holes at the condiment tray and tighten them.

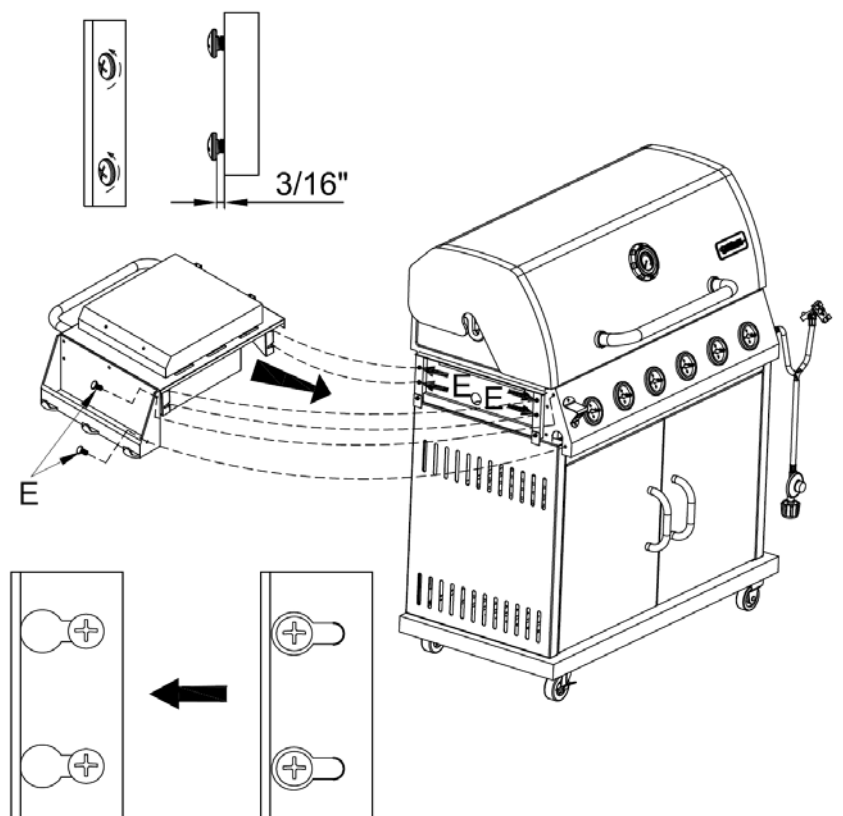

Hardware:

#E – 6 pcs

Assembly Instructions

Step 19.

Remove 2 pcs pre-attached **M5x10 bolts (J)** from the **Side Table Lid Handle (7)**.

Attach the Side Table Lid Handle to left side table lid by using the removed bolts.

Hardware:
#J – 2 pcs

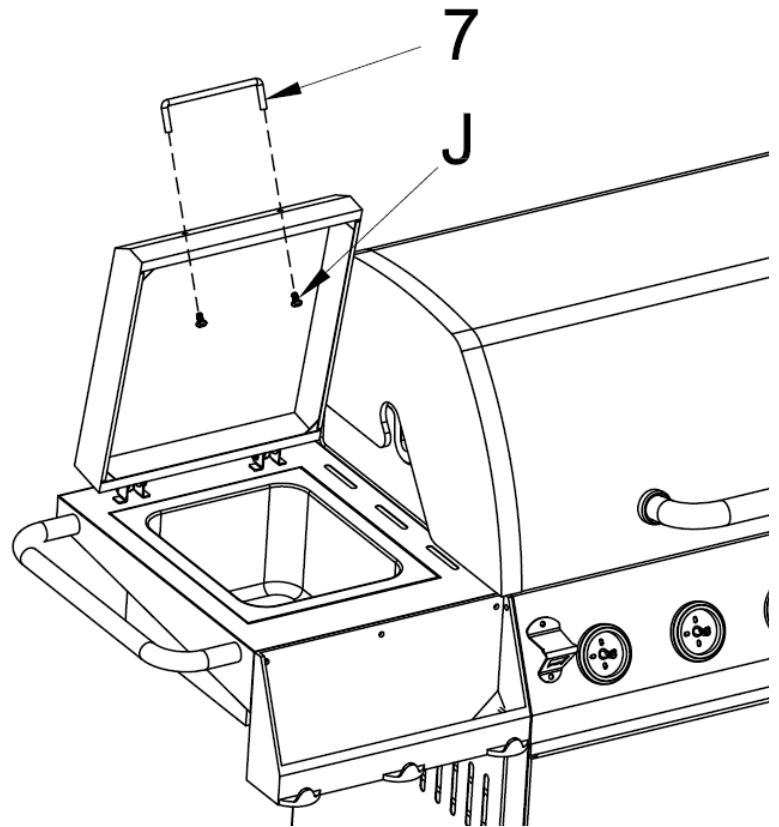

Step 20.

Attach the **Side Burner Control Panel Assembly (21)** to the **Side Burner Frame Assembly (19)** by using the 3 pcs **M6x10mm bolts (B)**.

Hardware:
#B – 3 pcs

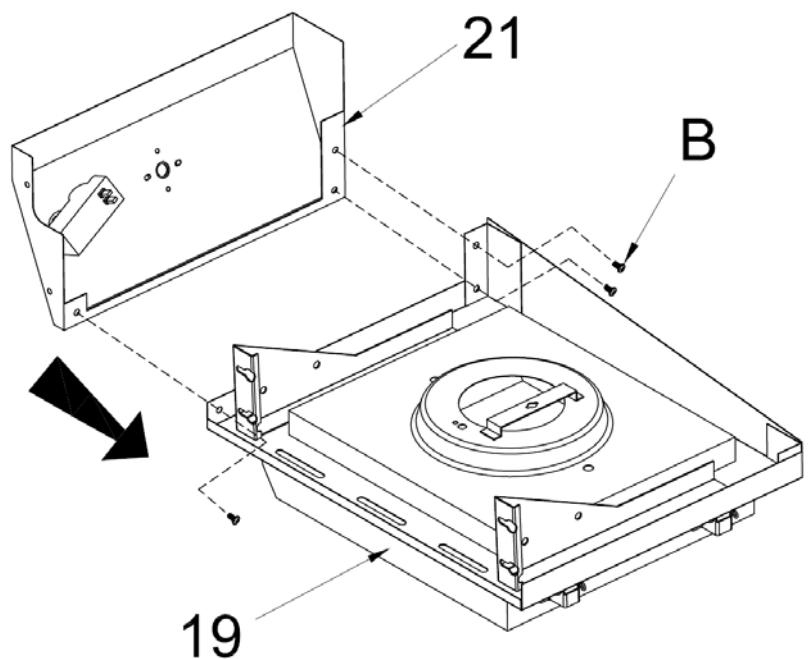

Assembly Instructions

Step 21.

Attach the **Side Burner Heat Shield (20)** to the side burner frame assembly by using the 2 pcs **M4x10mm bolts (F)**.

Hardware:
#F – 2 pcs

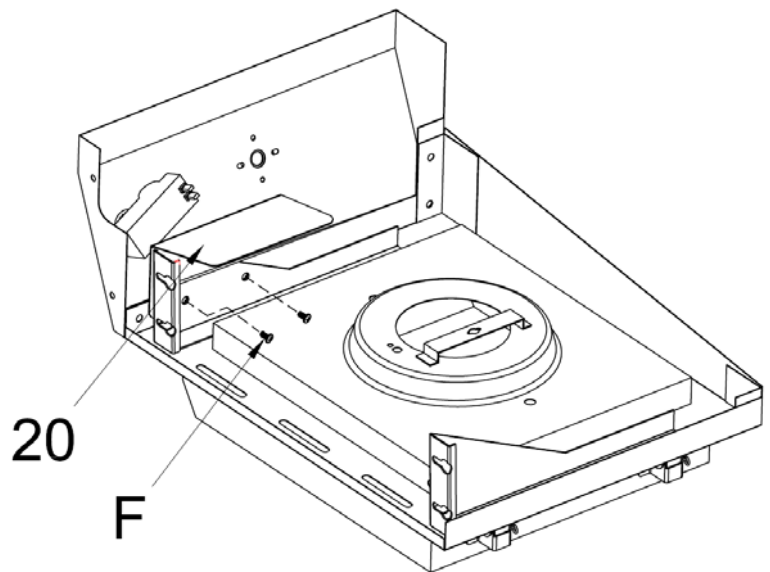

Step 22.

Remove 2 pcs pre-attached **M6x12mm bolts (E)** at the right side of the control panel. Loosen 4 pcs pre-attached bolts **M6x12 bolts (E)** on right side of the grill body and adjust to 3/16" clearance as shown. Position the holes on the right side table assembly through the bolts at grill body as shown. Push the right side table rightwards to lock it in place and tighten the **M6x12 bolts (E)**. Then insert 2pcs removed **M6x12mm bolts (E)** to the holes at the side burner control panel and tighten them.

Hardware:
#E – 6 pcs

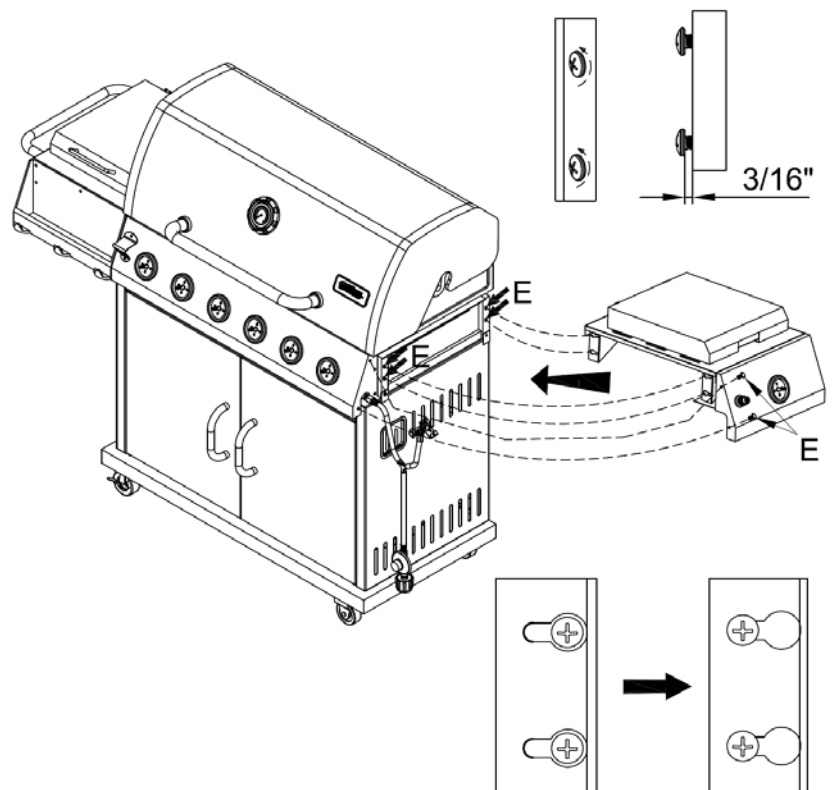

Assembly Instructions

Step 23.

Remove 2 pcs pre-assembled **M4x10mm Bolts (F)** from side burner valve.

Attach the valve to the control knob bezel at side burner control panel assembly. Fix the side burner valve onto the control knob bezel by using 2 pcs removed **M4x10mm Bolts (F)**.

Hardware:
#F – 4 pcs

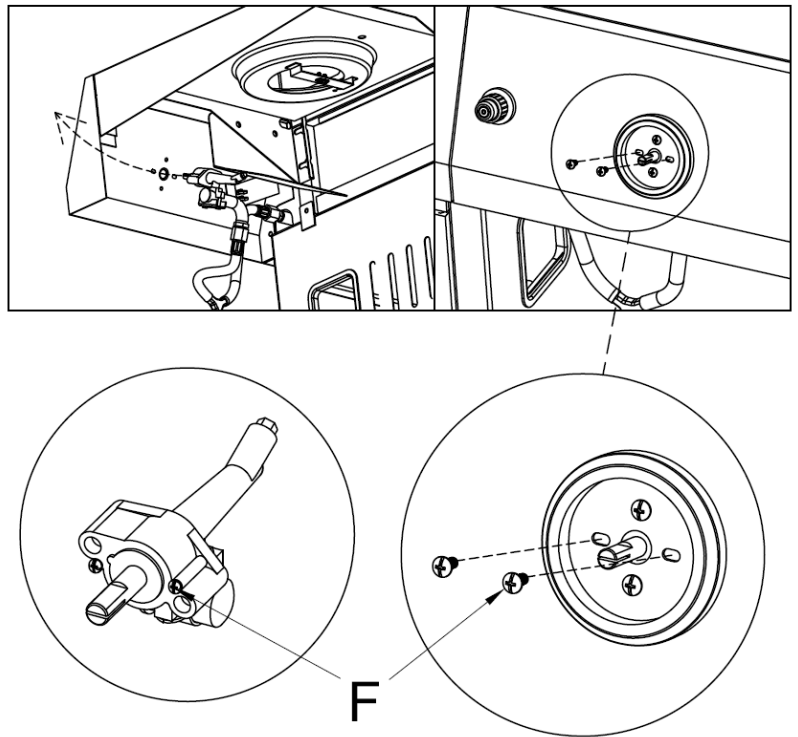

Step 24.

Remove 2 pcs pre-attached **M4x10mm Bolts (F)** and 2 pcs **M4 Washer (I)** from the **Side Burner Assembly (18)** then attach the burner to the side burner frame assembly.

Insert the side burner port into the valve outlet (orifice). Make sure that the burner port is inserted **STRAIGHTLY** into the valve outlet as shown.

Fix the side burner assembly to the burner bracket by using the removed bolts and washers as shown.

Hardware:
#F – 2 pcs
#I – 2 pcs

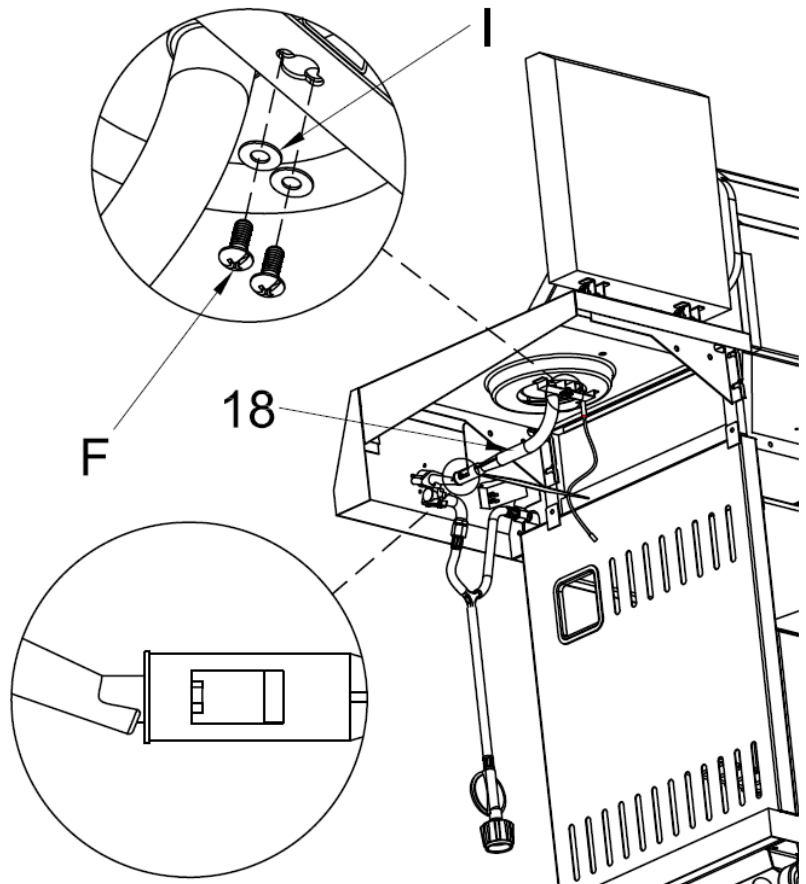

Assembly Instructions

Step 25.

Insert the terminals of ignition wire for the main burner and side burner to the connectors of igniter.

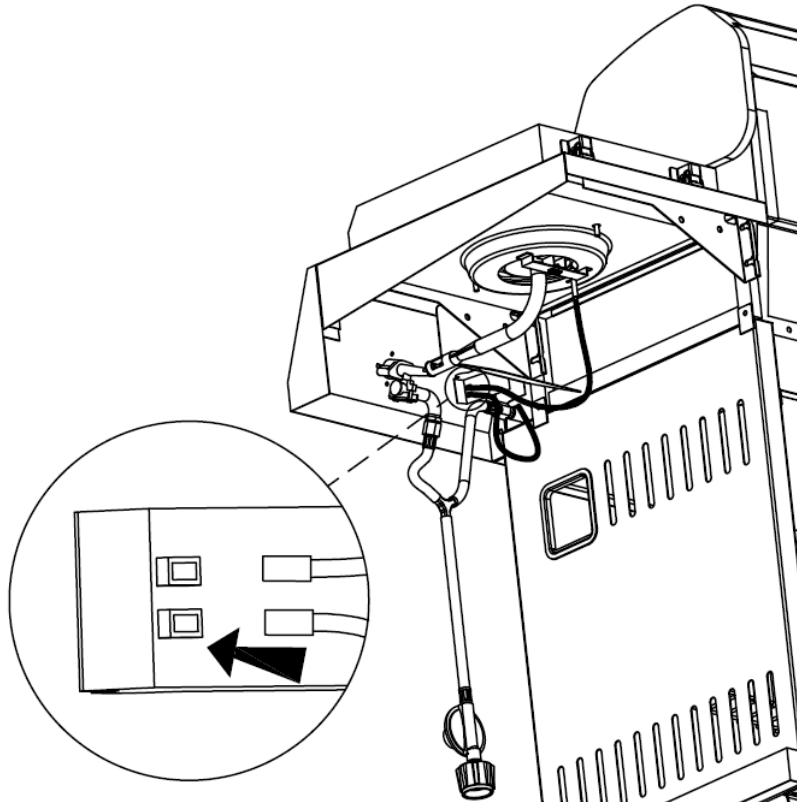

Step 26.

Insert the **Control Knobs / Side Burner Control Knobs (12)** to the pins of main burner and side burner valve. Apply light pressure to secure the knob firmly. Make sure that the flat end of the pin is aligned with the D-shape hole in control knob (with the triangle pointing upwards).

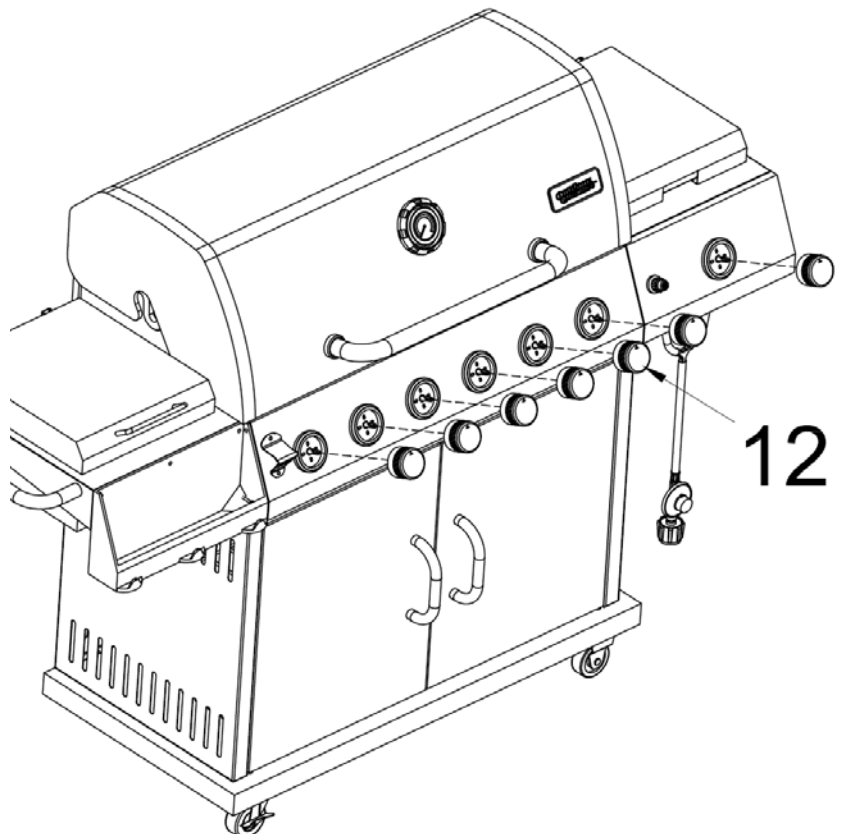

Assembly Instructions

Step 27.

Position the **Grease Cup (15)** into the holding bracket at the bottom of the grill body.

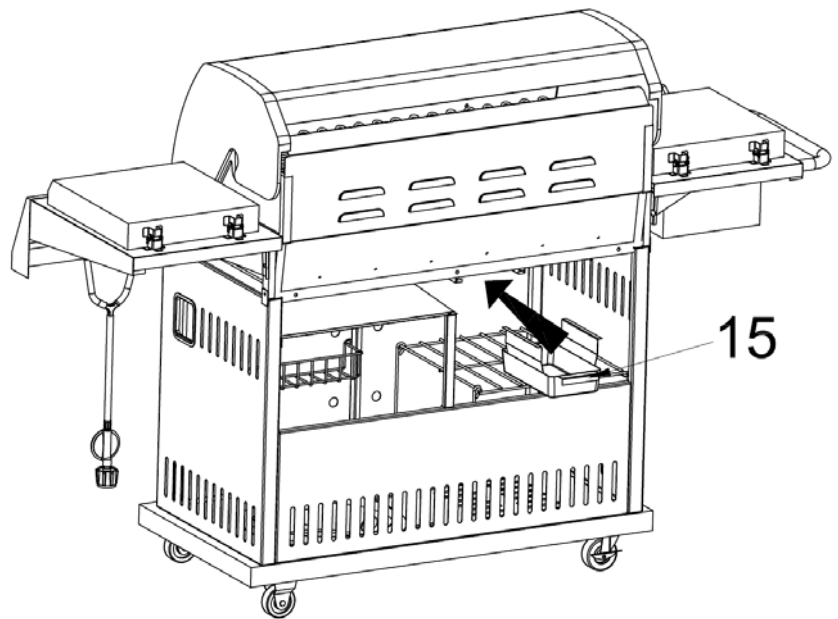

Step 28.

Place the **Ice Bin (11)**, **Flame Tamers (3)** and the **Side Burner Grate (17)** on the grill as shown.

Remark:

Clean the Ice Bin by hand only.
Do not immerse in water.

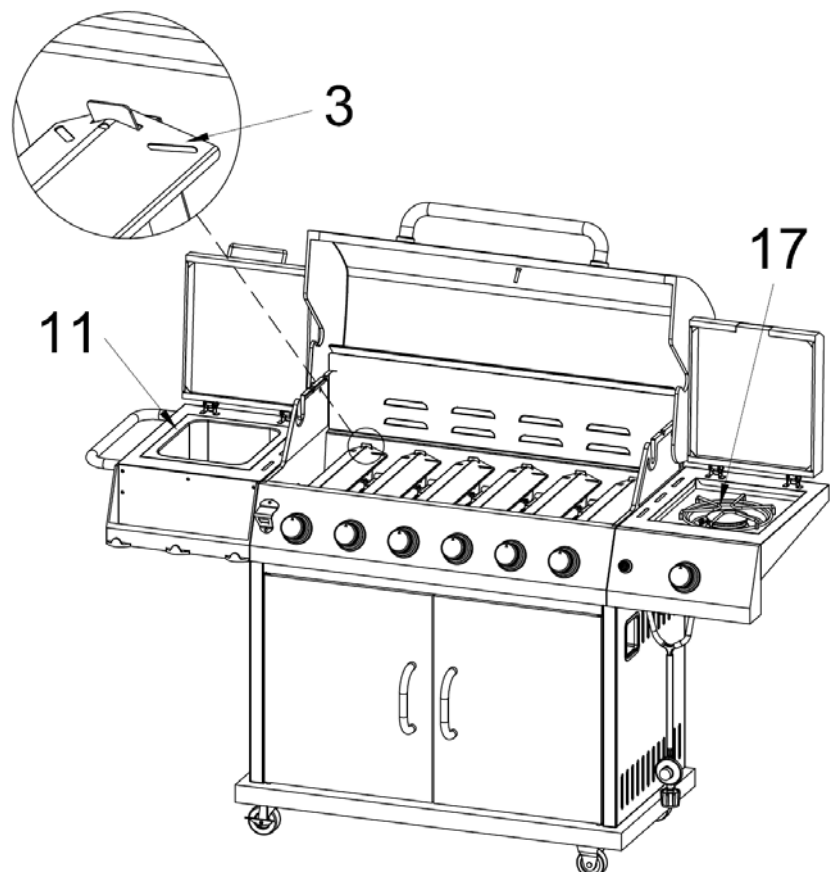

Assembly Instructions

Step 29.

Place the **Warming Rack (1)**, **Cooking Grates (2)** and the **Cast iron griddle (16)** on the grill as shown. Remember to check that the rear wire guard of the warming rack sits flush underneath the hexagonal nut of side panel of the fire box.

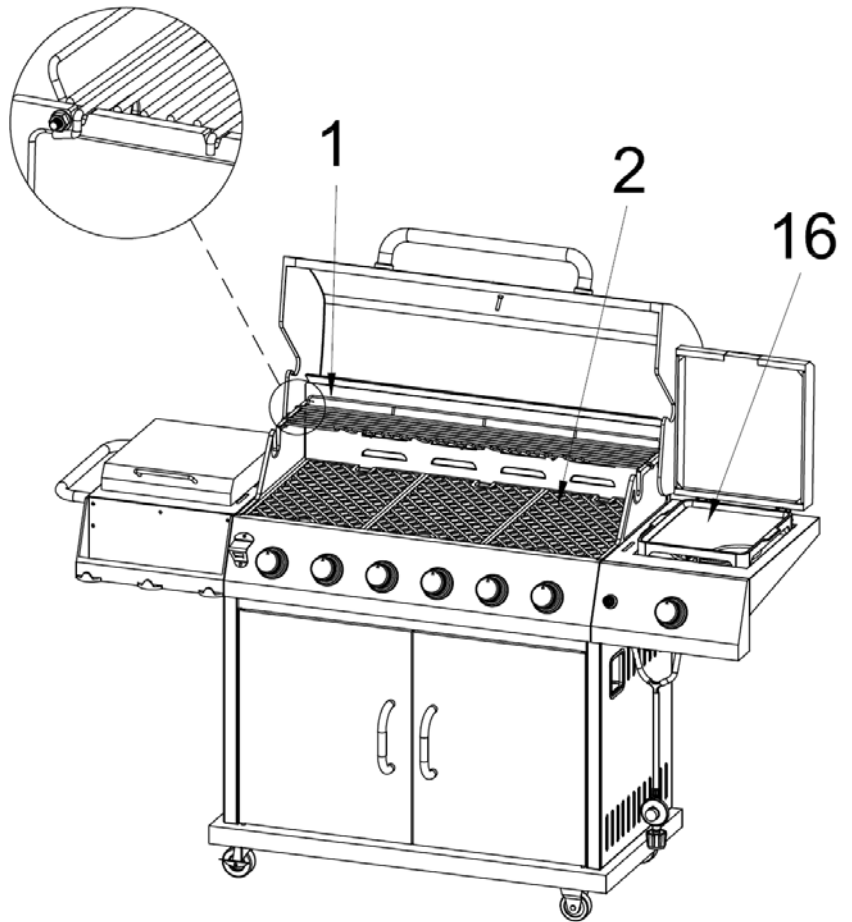

Step 30.

Install a **LR6/AA Battery (L)** into the igniter.

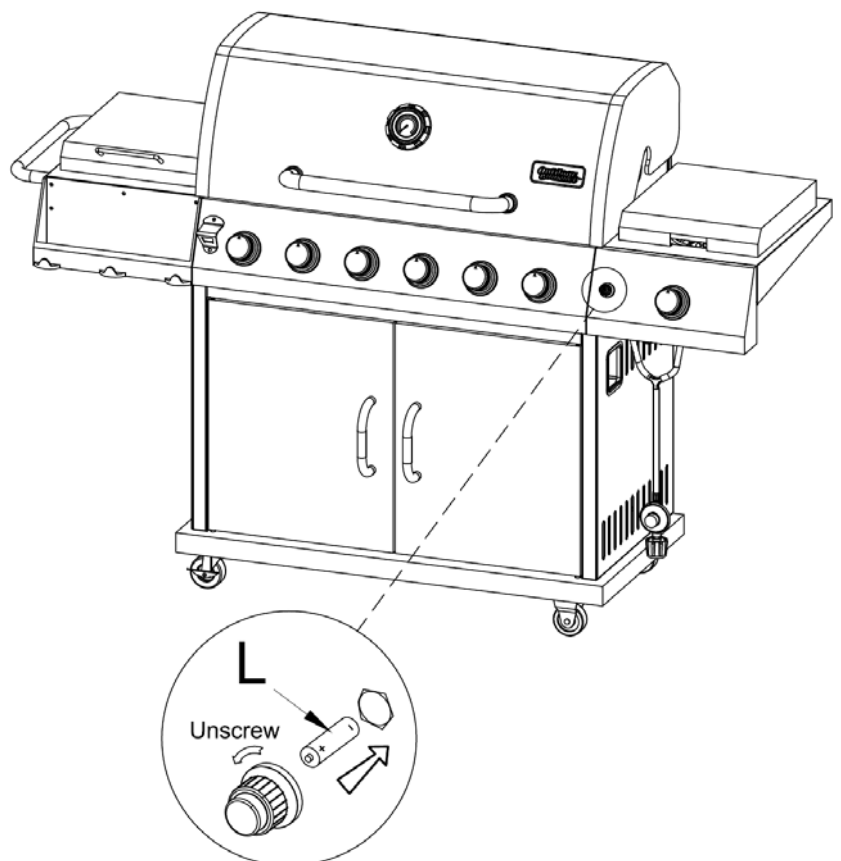

Assembly Instructions

Step 31.

Your unit is fully assembled!
Make sure to read and follow
the complete Instruction
Manual before using this
appliance.

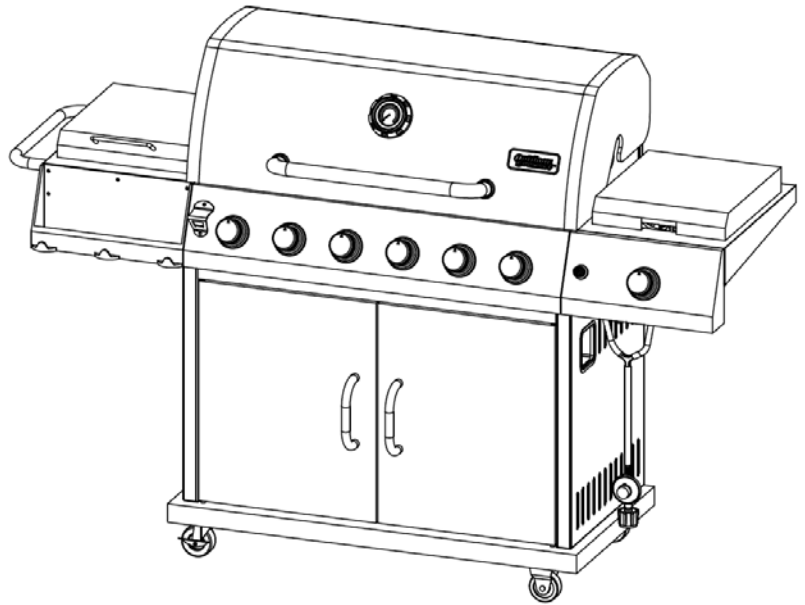

Leak Test

GENERAL

Although all gas connections on the grill are leak tested at the factory prior to shipment, a complete gas tightness check must be performed at the installation site due to possible mishandling in shipment, or excessive pressure unknowingly being applied to the unit.

Periodically check the entire system for leaks following the procedures listed below. Before using your grill you must check for leaks.

BEFORE TESTING

Make sure that all packing material is removed from the grill including the burner tie-down straps. Make a soap solution of one part liquid detergent and one part water. You will need a spray bottle, brush, or rag to apply the solution to the fittings. For the initial leak test, make sure the LP cylinder is full.



WARNING



- DO NOT SMOKE WHILE CONDUCTING LEAK TEST.
- NEVER PERFORM LEAK TEST WITH AN OPEN FLAME.
- If it is evident that there is excessive abrasion, wear or the hose is cut, it must be replaced prior to the appliance being put into operation. The replacement hose must be specified by the manufacturer.

TO TEST

1. Make sure the control valves are in the **OFF** position then turn on the gas supply.

2. Check all connections from the gas cylinder, LP gas regulator and supply valve up to and including all connections to the pipe that go to the burners (Following are the points where the soap water mixture need to apply). Soap bubbles will appear if a leak is present.

- A. Supply tank (Cylinder) weld.
- B. Connection nut to tank valve.
- C. Back side of connection nut to brass nipple.
- D. Brass nipple connections to gas supply hoses.
- E. Regulator connections to gas supply hose.
- F. Gas supply hose connection to side burner valve assembly.
- G. Side burner valve stem cap.
- H. Side burner connection to hose.
- I. Hose connection to gas manifold.
- J. The full length of gas supply hose.
- K. Tank valve to cylinder.

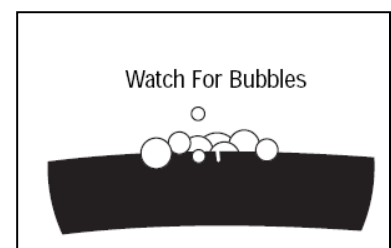
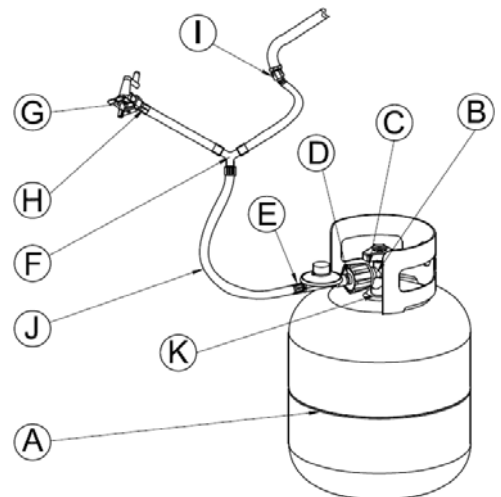

Leak Test

3. If a leak is present, immediately turn off the gas supply and tighten the leaky fittings.
4. Turn the gas back on and recheck.
5. Should gas continue to leak from any of the fittings, turn off the gas supply and contact customer service department at 1-888-922-2336, 7:00 am to 12:00 am CST (daily) or 1-888-837-1380, Mon to Fri, 10:00am – 7:00pm CST.

Lighting Instructions

BEFORE LIGHTING



WARNING



- Inspect the gas supply hose prior to turning the gas **ON**.
- If there is evidence of cuts, wear, or abrasion, the hose must be replaced prior to use.
- Do not use the grill if the odor of gas is present.
- Only the pressure regulator and hose assembly supplied with the unit should be used.
- Perform the "**LEAK TEST**" according to the instructions before operating the grill.
- **ALWAYS** keep your face and body away from the burner while lighting.

LIGHTING THE MAIN BURNERS OF GRILL

1. Read instructions before lighting.
2. Open lid before lighting the burner.
3. Make sure all control knobs are in the "**OFF**" position.

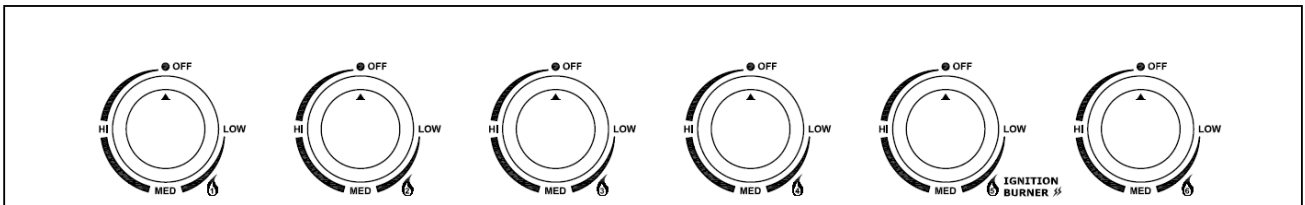

4. Turn ON gas valve from LP tank.
5. The **IGNITION BURNER** is the 5th control knob from the left. Light it first.
Push and turn the 5th burner control knob to "**HI**" then immediately press and hold the electronic ignition button at the side burner control panel.

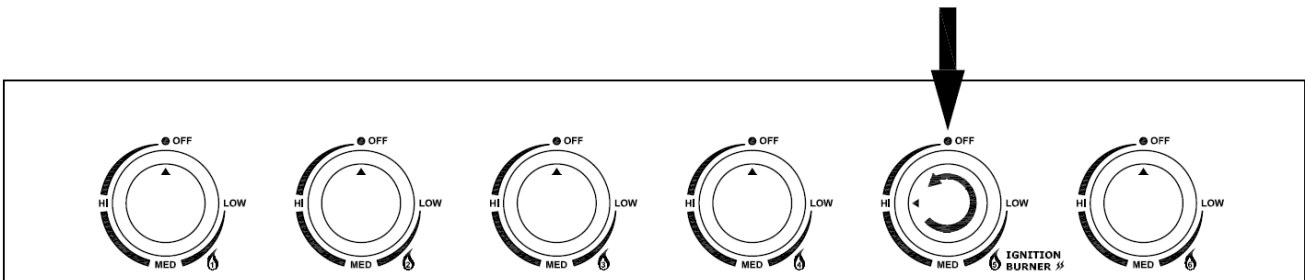

6. If ignition does NOT occur in 5 seconds, turn the burner control knob off, wait for 5 minutes to allow gas to dissipate. Repeat the lighting procedure.
7. Once the **IGNITION BURNER** is lit, you may light burners 4, 3, 2, 1 and 6 in that order. Just press and turn the control knob to "**HI**".

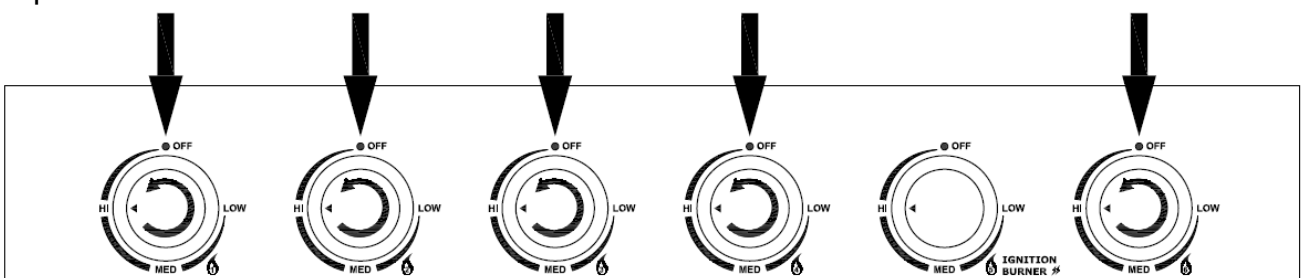

Lighting Instructions

- To turn burners off, turn the control knobs clockwise to "Hi" then press down the knob and continue to turn clockwise until they locked in the "OFF" position.

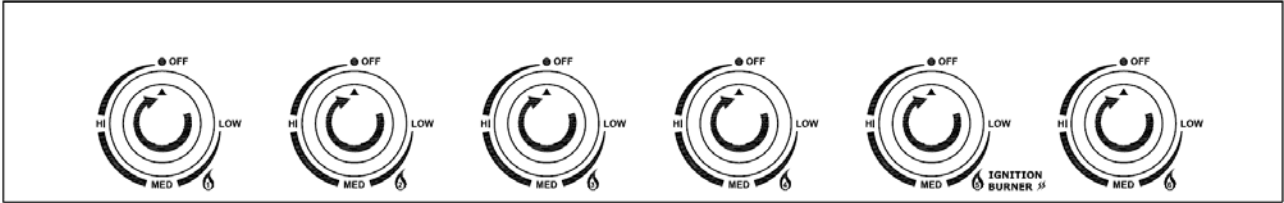

LIGHTING THE SIDE BURNER OF GRILL

- Read instructions before lighting.
- Open lid before lighting the burner.
- Make sure control knob is in the "OFF" position.

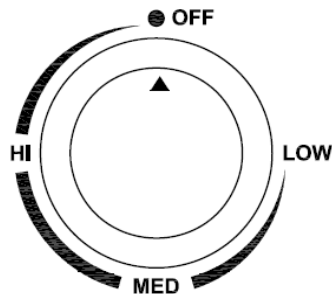

- Turn on gas valve from LP tank.
- Push and turn the side burner control knob to "HI" then immediately press and hold the electronic ignition button at the side burner control panel.

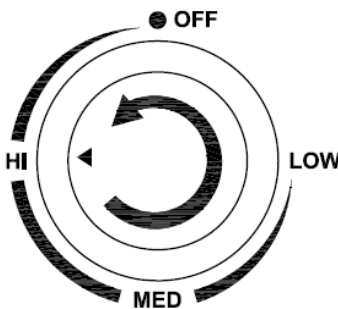

- If ignition DOES NOT occur in 5 seconds, turn the burner control knob off, wait for 5 minutes to allow gas to dissipate. Repeat the lighting procedure.
- To switch burner off, turn the control knob clockwise to "HI" then press down the knob and continue to turn clockwise until locked in the "OFF" position.

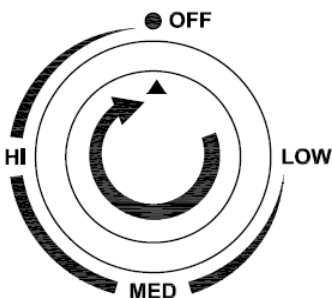

Lighting Instructions

USING MATCH HOLDER TO LIGHT BURNER

1. Turn off all burner valves.
2. Make sure the lid is open.
3. Take off the match holder from the left fire box panel as shown.
4. Place a lighted match on the match holder and hold next to the burner.
5. Turn the control knob(s) to the "HI" position. Burner should light immediately.
6. If the burner does not light in 5 seconds, turn the knob off and wait for 5 minutes then repeat above procedures.

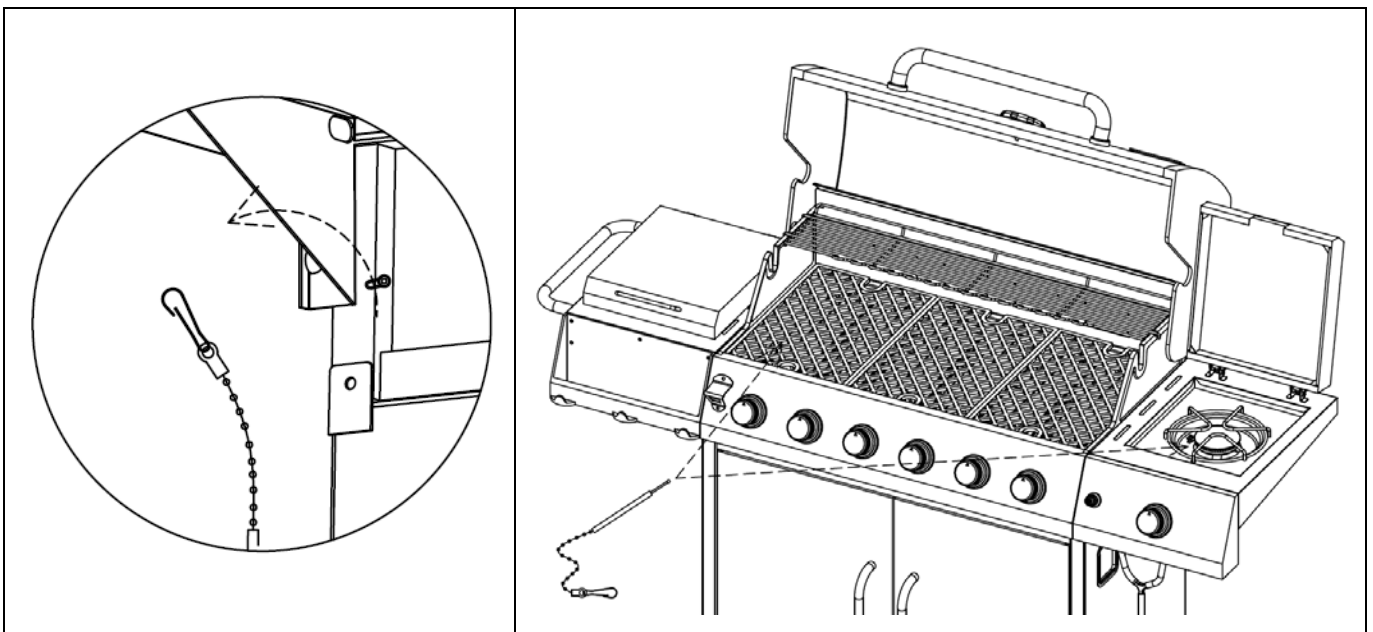

DANGER



- Keep your face and hands as far away from the grill as possible when lighting it.

FLAME CHARACTERISTICS

This procedure outlines how to check for proper burner flame characteristics.

Burner flames should be blue and stable with little yellow tips, with no excessive noise, or lifting. If the flame is yellow, it indicates insufficient air. If the flame is noisy and tends to lift away from the burner, it indicates too much air. If any of these conditions exist call our customer service line. Visually check the burner flames prior to each use. The flames should look like this picture. If not, refer to the burner maintenance part of this manual.

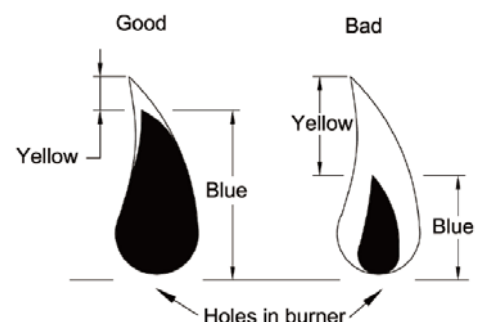

Care and Maintenance

You should inspect the burners at least once a year or immediately after any of the following conditions occur:

1. The smell of gas in conjunction with the burner flames appearing yellow.
2. The grill does not reach temperature.
3. The grill heats unevenly.
4. The burners make popping noises.



WARNING



- ENSURE that the gas supply and the knobs are in **OFF** position **BEFORE** cleaning the burners.

BURNER CLEANING:

1. Turn off the gas supply and make sure all the knobs are in the **OFF** position.
2. Wait for the grill to cool.
3. Open the lid and remove the cooking grates and flame tamers.
4. Remove the cotter pin and lift the burner out of the firebox.
5. Checking and cleaning burner/venturi tubes for inserts and insert nests. A clogged tube can lead to a fire beneath the grill.
6. Clean the exterior of the burner with a brass brush. Use a metal scraper to remove stubborn stains.
7. Clear clogged ports with a straightened paper clip. Never use a wooden toothpick as it may break off and clog the port.
8. If insects or other obstructions are blocking the flow of gas through the burner, call customer service at 1-888-922-2336 or 1-888-837-1380. Make sure to center the burner over the orifice.

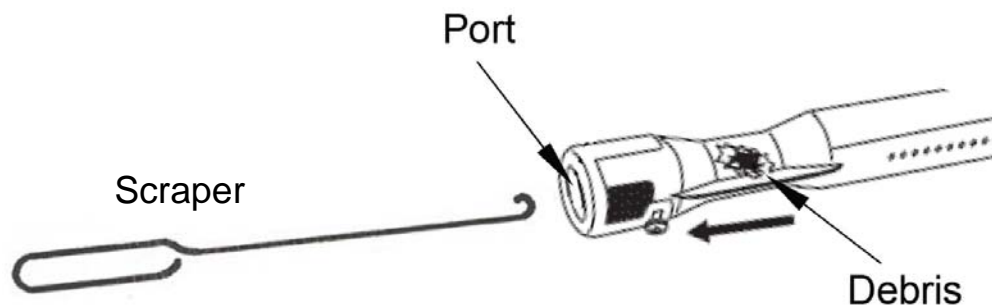

Care and Maintenance

TO REINSTALL THE MAIN BURNERS:

1. Insert the burner into the burner valve.
2. Firmly seat the valve orifice into the burner tube. Make sure the Valve orifice is inserted STRAIGHTLY into the burner tube.
3. Align the burner with the fixing slot at firebox, insert the cotter pin to the hole of the fixing slot.

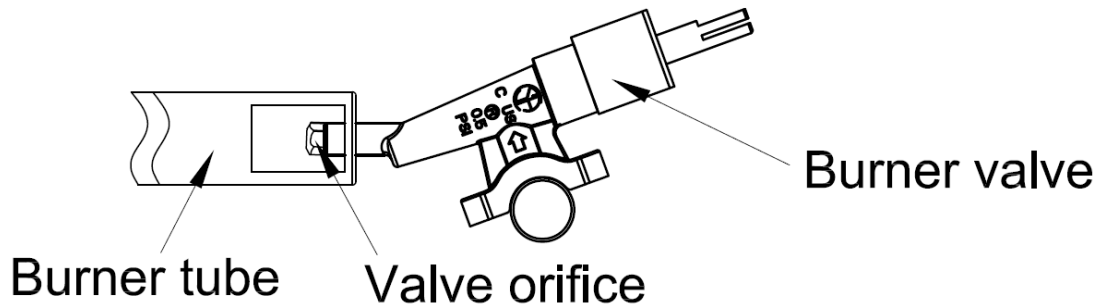

MAIN BURNER REPLACEMENT:

1. Remove the flame tamers.
2. Remove the burner cotter pin as shown.
3. Remove the burner from the grill body.

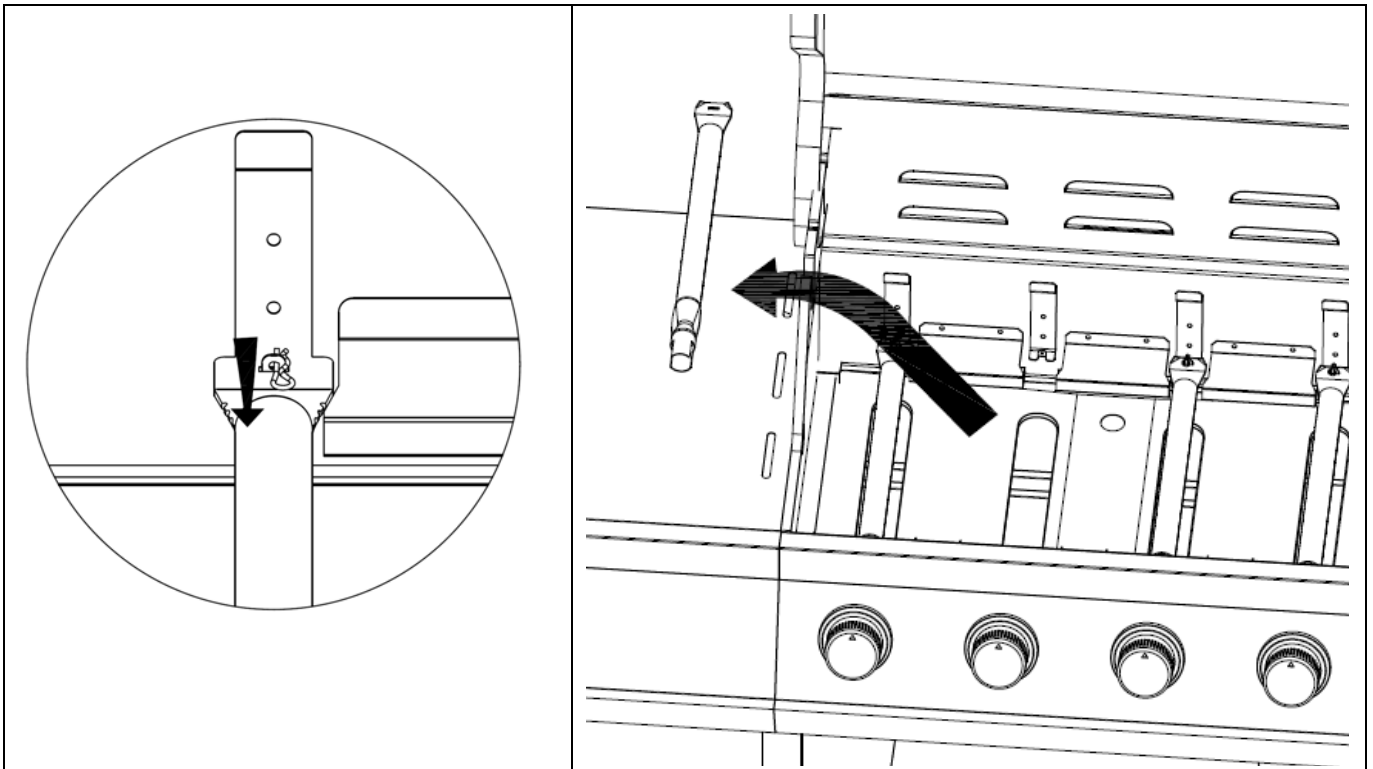

Care and Maintenance

SIDE BURNER REPLACEMENT:

1. Open the side burner lid and remove the cast iron griddle and side burner grate.
2. Remove two burner fixing bolts at the bottom of side burner assembly as shown.
3. Remove the ignition wire on the side burner.
4. Remove the burner as shown.

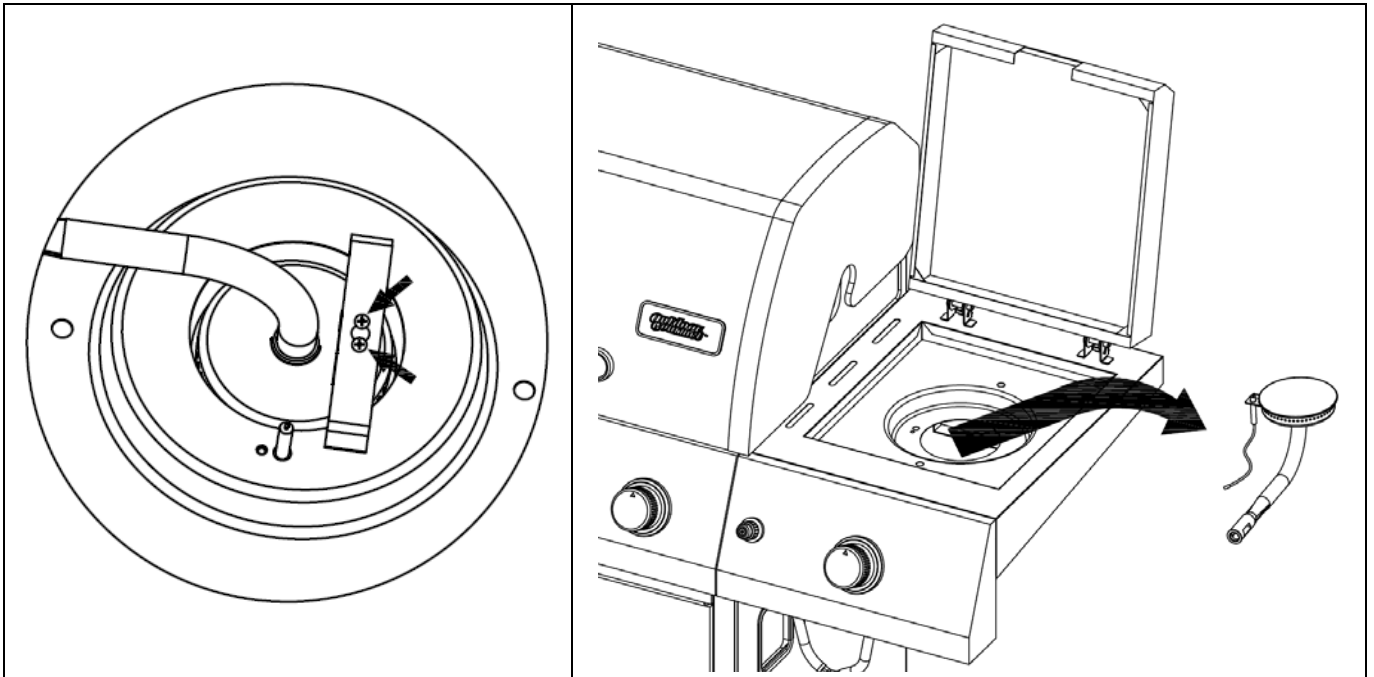

PROPERLY INSTALL THE BURNER

Firmly seat the valve orifice into the burner tube. Make sure the valve orifice is inserted **STRAIGHTLY** into the burner tube.

Burner flames will be yellow, with excessive noise, lifting or flash back if the burner is not installed properly.

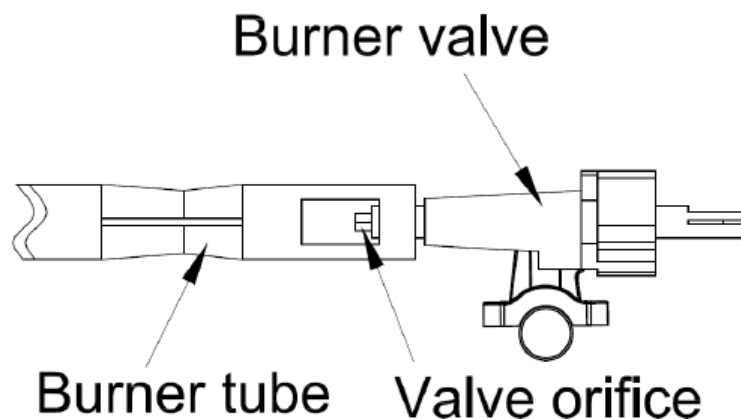

Trouble Shooting

Problem:	Possible Causes:	Corrective Actions:
Burner cannot light.	<ol style="list-style-type: none"> 1. LP cylinder fuel is used up. 2. Bad electrode spark. 3. Burner may not be properly seated. 4. Burner may be obstructed. 5. The cylinder valve may be closed. 6. Regulator is not properly seated on cylinder valve. 	<ol style="list-style-type: none"> 1. Change a new full LP cylinder. 2. Check to see if the spark will match with the vents of burner. Electrode or collector may need adjustment. 3. Refer to the section of "To Reinstall The Main Burners" at P.40 to reinstall burner properly. 4. Refer to the section of "Burner Cleaning" at P.39 to clean the burner. 5. Check then open the cylinder valve. 6. Refer to the section of "Connection Procedures" at P.6 to reinstall the regulator properly.
Fire at control knob.	<ol style="list-style-type: none"> 1. Burner is improperly seated on control valve. 2. Gas connections may be loose. 3. Burner holes may be obstructed. 	<ol style="list-style-type: none"> 1. Refer to the section of "To Reinstall The Main Burners" at P.40 to reinstall burner properly. 2. Refer to the section of "Leak Test" at P.34-35 to check and tighten all connections. 3. Refer to the section of "Burner Cleaning" at P.39 to clean the burner.
Yellow flame at burner.	<ol style="list-style-type: none"> 1. Burner is obstructed. 	<ol style="list-style-type: none"> 1. Refer to the section of "Burner Cleaning" at P.39 to clean the burner.
Flame blows out on "LOW".	<ol style="list-style-type: none"> 1. Burner holes may be obstructed. 2. Grill is not sufficiently preheated. 3. Burner is improperly seated on control valve. 	<ol style="list-style-type: none"> 1. Refer to the section of "Burner Cleaning" at P.39 to clean the burner. 2. Preheat the grill for sufficient time. 3. Refer to the section of "To Reinstall The Main Burners" at P.40 to reinstall burner properly.
Burner does not get hot enough.	<ol style="list-style-type: none"> 1. Flow control device has been activated in regulator. 	<ol style="list-style-type: none"> 1. Reset the regulator. Turn off all burners and close the LP tank valve. Disconnect the regulator from the LP tank and wait for one minute. Reconnect the regulator to the LP tank and slowly open the LP tank valve until the valve is fully open. Light all burners and observe the temperature.
Grill is too hot.	<ol style="list-style-type: none"> 1. Excess grease build-up causing grease fires. 2. Damaged or faulty regulator. 	<ol style="list-style-type: none"> 1. Refer to the section of "Care and Maintenance" at P.39-41 to clean the grill properly. 2. Replace the damaged parts with factory authorized component.

Warranty Information

1. Manufacturer warrants this Product to be free from defects in workmanship and materials for a period of 1 year from the date of purchase, PROVIDED claims are submitted, in writing, with proof of purchase.
2. If any part of this item fails because of a manufacturing defect within the Limited Warranty Period, Manufacturer offers to replace such part(s) provide that such parts have not been improperly repaired, altered, or tampered with or subject to misuse, abuse or exposed to corrosive conditions. This Limited Warranty is, however, subject to certain limitations, exclusions, time limits and exceptions (Hereinafter "Conditions") as listed below. Read these Conditions carefully.
3. This Limited Warranty shall be limited to the replacement or repair of any part(s) which Manufacturer determines, after reasonable examination, to have been defective at the time of manufacturing and manufacturer's obligation(s) shall be limited to replacement, if any, of defective part(s) which shall be shipped at Original Purchaser's expense to Original Purchaser's designated shipping address.
4. This Limited Warranty is given to and covers the **ORIGINAL PURCHASER ONLY** and such coverage terminates 1 year from the date of purchase.
5. **DAMAGE LIMITATION WARNING:** IN NO EVENT SHALL MANUFACTURER BE LIABLE FOR ANY INCIDENTAL OR CONSEQUENTIAL DAMAGES, INCLUDING (BUT NOT LIMITED TO) LOSS OF USE OF THE PRODUCT, LOSS OF TIME, LOSS OF FOOD, INCONVENIENCE, EXPENSES FOR TRAVEL, TRANSPORTATION LODGING EXPENSES, LOSS BY DAMAGE TO PERSONAL PROPERTY OR LOSS OF INCOME, PROFITS OR REVENUE.
6. **MANUFACTURER'S OBLIGATION:** Manufacturer's liability shall be limited to the delivery of a good, merchantable Product and, if necessary, the repair or replacement, at manufacturer's option, of any defective part or unit.
7. **TRANSFER LIMITATIONS:** This Limited Warranty is not assignable or transferable. It covers only the original purchaser.
8. **RESERVED RIGHT TO CHANGE:** Manufacturer reserves the right to make changes or improvements to products it produces in the future without imposing on itself any obligations to install the same improvements in the products it has previously manufactured.
9. This Limited Warranty gives the Original Purchaser specific legal rights but there may be other rights which vary by jurisdiction.
10. This warranty does not cover the following items:
 - Chips or scratches on porcelain or painted surfaces.
 - Rust or corrosion is not deemed a manufacturing or materials defect.
 - Discoloration or loss of paint due to handling during assembly, heat or cleaning products. Paint may require touch up.
 - Stainless steel discoloration or corrosion.
 - Consumables such as batteries.

IF CUSTOMER SERVICE BECOME NECESSARY:

1. The Original Purchaser is responsible for shipping and handling charges of the returned item(s) and replacement parts, if any.
2. All parts to be replaced will need to be shipped before replacement items will be sent.
3. Follow the Customer Service Representative's instructions exactly. If a return is necessary, it must be packed carefully and shipped prepaid.

Should you encounter any problem,
CALL US FIRST.
Do not return product to the store.
WE CAN HELP.

For assistance, contact customer service at customerservice@academy.com /
at 1-888-922-2336, 7:00 am to 12:00 am CST (daily)
or
customerservice@rankam.com /
at 1-888-837-1380, Mon to Fri, 10:00am – 7:00pm CST