

This Owner's Manual is provided and hosted by [Appliance Factory Parts](#).



Rankam CG2065303-RG Owner's Manual

[Shop genuine replacement parts for Rankam
CG2065303-RG](#)



[Find Your Rankam Grill Parts - Select From 123 Models](#)

----- Manual continues below -----



Desperado 17.5 inch Grill

MODEL# CG2065303-RG

OWNER'S MANUAL

ASSEMBLY AND OPERATING INSTRUCTIONS

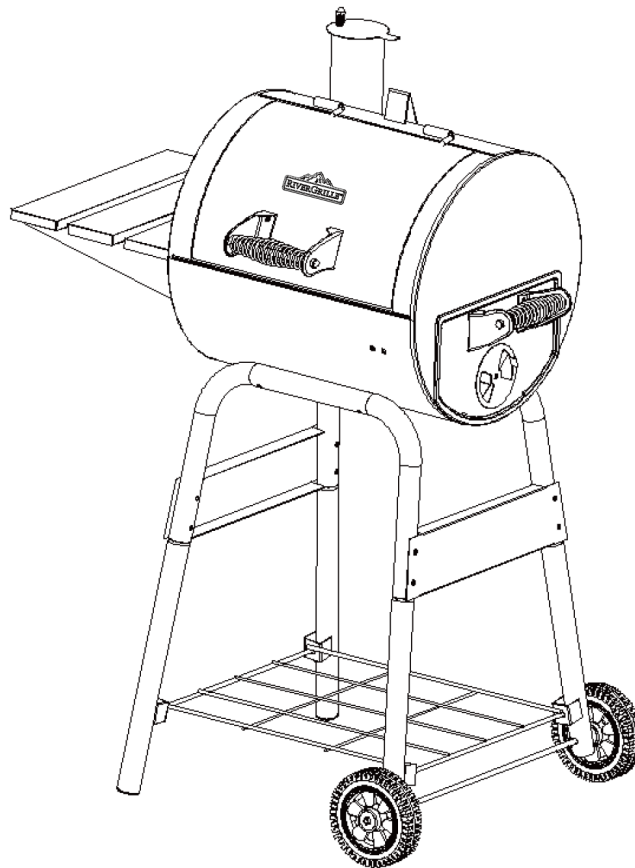

Tools required for assembly: (Not Included) Pliers, Philips Screwdrivers, Adjustable Wrench.

Keep this manual for future reference.



WARNING



OUTDOOR USE ONLY.

Never use grill indoors. Carbon Monoxide poisoning that can lead to death.



WARNING



- Only use this grill on a hard, level, non-combustible, stable surface (concrete, ground, etc.) capable of supporting the weight of the grill. Never use on wooden or other surfaces that could burn.
- When the grill is in use, maintain a clearance of at least 36" (1 m) between the hot grill and any combustible materials, such as bushes, trees, wooden decks, wooden fences, buildings, etc. Do not place a hot grill under a roof overhang or in any other enclosed area.
- The maximum weight of charcoal to be used is 2.2 lbs (1.0kg). Too much charcoal may cause the surface coating to peel off.
- **FOR OUTDOOR USE ONLY. DO NOT operate the grill indoors or in an enclosed area** because of carbon monoxide poisoning that can lead to personal injury or death.
- For household use only. Do not use this grill for other than its intended purpose.
- We recommend the use of a charcoal chimney starter to avoid the dangers associated with charcoal lighter fluid. If you choose to use charcoal lighter fluid, only use one approved for lighting charcoal. Carefully read the manufacturer's warnings and instructions on the charcoal lighter fluid and charcoal prior to using them. Store charcoal lighter fluid safely away from the grill.
- When using charcoal lighter fluid, allow the charcoal to burn with the grill lid and doors open until covered with a light ash (approximately 20 minutes). This will allow the charcoal lighter fluid to burn off. Failure to do this could trap fumes from charcoal lighter fluid in the grill and may result in a flash fire or explosion when the lid is opened.
- Do not use gasoline, kerosene or alcohol for lighting charcoal. Use of any of these or similar products could cause an explosion possibly leading to severe bodily injury.
- Never add charcoal lighter fluid to hot or even warm coals, as flashback may occur causing severe burns.
- Place the grill in an area where children and pets cannot come into contact with it. Close supervision is necessary when the grill is in use.
- Do not leave the grill unattended when in use.
- When adding charcoal and / or wood, use extreme caution and follow instructions in the "Adding Charcoal / Wood During Cooking" section of this manual.
- Do not store or use the grill near gasoline or other flammable liquids, gases or where flammable vapours may be present.
- Do not store lighter fluid or other flammable liquids or materials under the grill.
- Use caution when adjusting the charcoal grate height, use oven mitts. The handle will be hot when in use.
- Never raise or lower the charcoal grate when water smoking as hot water may splash on to coals creating a burst of hot steam and coals.

Grill is hot when in use. To avoid burns:

- DO NOT attempt to move the grill.
- Wear protective gloves or oven mitts.
- DO NOT touch any hot grill surfaces.
- DO NOT wear loose clothing or allow hair to come in contact with the grill.



WARNING



The air vent will be hot during operation. Please wear protective glove to adjust the air vent during operation.



WARNING



- When grilling, grease from meat may drip into the charcoal and cause a grease fire. If this should happen, close the lid to suffocate the flame. Do not use water to extinguish grease fires.
- Use caution when opening the lid. Keep hands, face and body a safe distance away. Flash flare ups may occur when air comes into contact with fire or hot coals.
- Never place more than 5 lbs (2.3 kg) on the front and side tables.
- Do not allow charcoal and/or wood to rest on the walls of the grill. Doing so will greatly reduce the life of the metal and finish of your grill.
- Use caution during assembly and while operating your grill to avoid scrapes or cuts from sharp edges of metal parts. Use caution when reaching into or under the grill.
- When opening the lid, be sure it is fully opened and secure to prevent it from closing unexpectedly.
- In windy weather, place the grill in an outdoor area that is protected from the wind.
- Close the lid to suffocate flame.
- Never leave coals and ashes in the grill unattended. Before the grill can be left unattended, remaining coals and ashes must be removed from the grill. Use caution to protect yourself and property. Carefully place the remaining coals and ashes in a non-combustible metal container and saturate completely with water. Allow the coals and water to remain in the metal container 24 hours prior to disposing.
- Extinguished coals and ashes should be placed a safe distance from all structures and combustible materials.
- With a garden hose, completely wet the surface beneath and around the grill to extinguish any ashes, coals or embers which may have fallen during the cooking or cleaning process.
- After each use, clean the grill thoroughly and apply a light coat of vegetable oil to prevent rusting. Cover the grill to protect it from excessive rusting.
- Use caution when lifting or moving the grill to prevent strains and back injuries.
- We advise that a fire extinguisher be on hand. Refer to your local authority to determine proper size and type of fire extinguisher.
- Store the grill out of reach of children and in a dry location when not in use.
- Do not attempt to services the grill other than by normal maintenance, as explained in the “After-Use Safety” and “Proper Care & Maintenance” sections of this manual.
- Properly dispose of all packaging material.
- Use caution and common sense when operating your grill.
- Failure to adhere to safety warnings and guidelines in this manual could result in bodily injury or property damage.
- Save this manual for future reference.

Wash your hands after handling this product



WARNING: FUELS USED IN WOOD OR CHARCOAL BURNING APPLIANCES, AND THE PRODUCTS OF COMBUSTION OF SUCH FUELS, CAN EXPOSE YOU TO CHEMICALS INCLUDING CARBON BLACK, WHICH IS KNOWN TO THE STATE OF CALIFORNIA TO CAUSE CANCER, AND CARBON MONOXIDE, WHICH IS KNOWN TO THE STATE OF CALIFORNIA TO CAUSE BIRTH DEFECTS OR OTHER REPRODUCTIVE HARM. *For more information go to: www.P65Warnings.ca.gov.*

ASSEMBLY INSTRUCTIONS

THANK YOU FOR PURCHASING THIS DESPERADO SMOKER

Read all safety warnings & assembly instructions carefully before assembling or operating your grill.

For assembly assistance, missing or damaged parts, please call Rankam customer service at **1-888-837-1380 (U.S. only)**, Monday thru Friday 8AM to 5PM Pacific Standard Time or email to customerservice@rankam.com

(Proof of purchase will be required.)

Inspect contents of the box to ensure all parts are included and undamaged.

Two people are required for assembly of this grill.







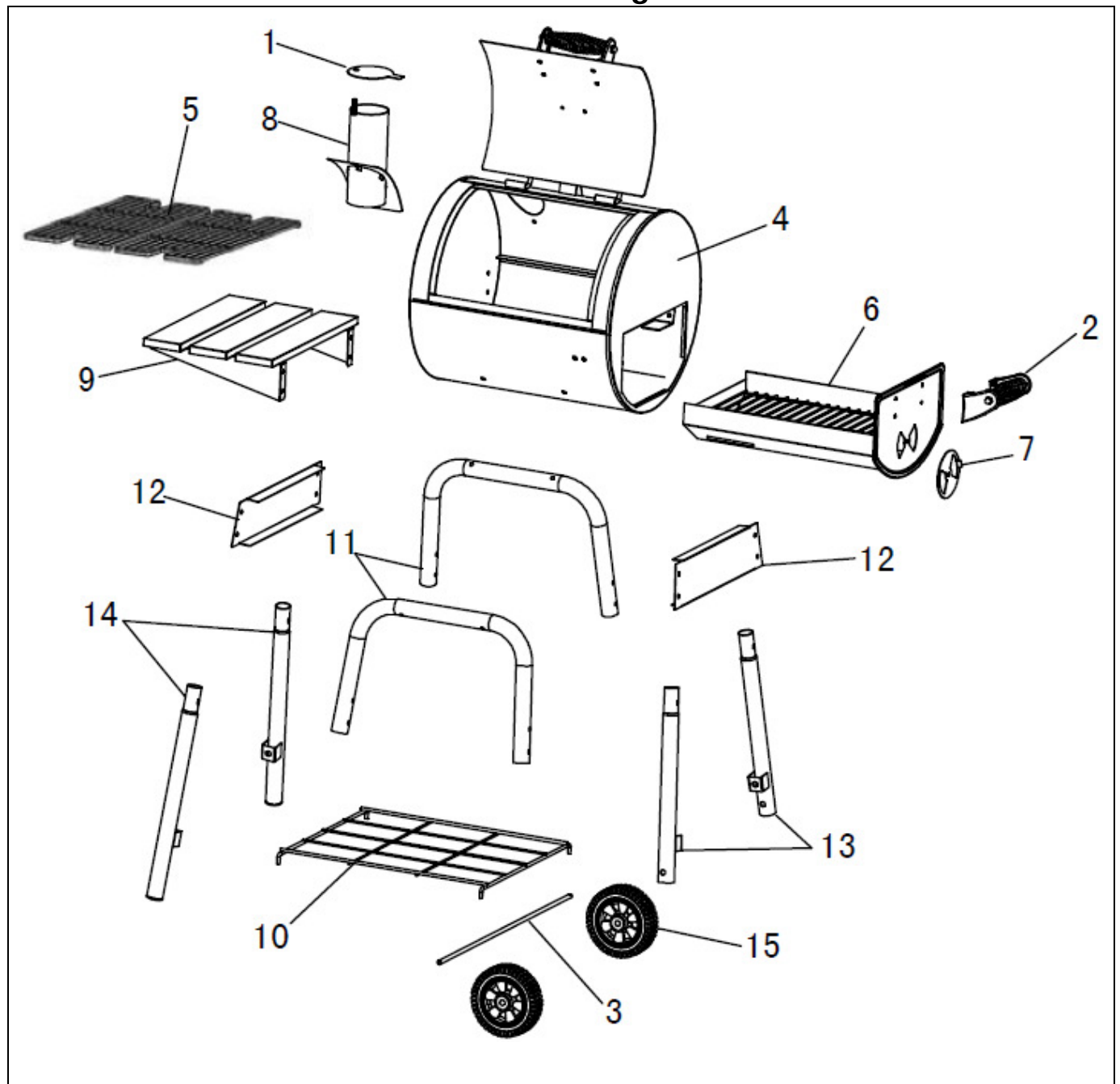

The following **tools** are required for assembly and are not **included**:

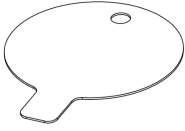
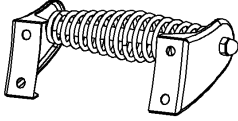
- Pliers
- Philips Screwdrivers
- Adjustable Wrench

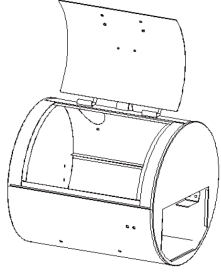
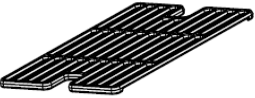
Product Diagram

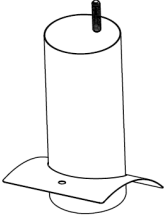
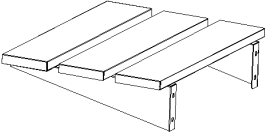
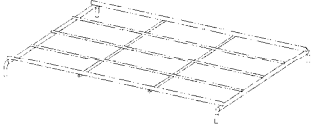
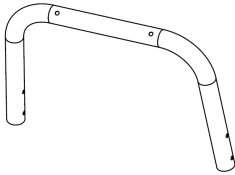
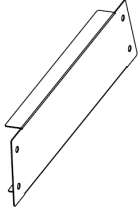

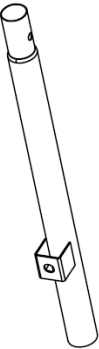



Components

<p>1. Chimney Cover</p>  <p style="text-align: right;">1 pc</p>	<p>2. Handle</p>  <p style="text-align: right;">2 pcs</p>	<p>3. Axle</p>  <p style="text-align: right;">1 pc</p>	<p>4. Grill body</p>  <p style="text-align: right;">1 pc</p>
<p>5. Cooking grates</p>  <p style="text-align: right;">2 pcs</p>	<p>6. Ash Pan</p>  <p style="text-align: right;">1 pc</p>	<p>7. Air Vent</p>  <p style="text-align: right;">1 pc</p>	<p>8. Chimney</p>  <p style="text-align: right;">1 pc</p>
<p>9. Side Table</p>  <p style="text-align: right;">1 pc</p>	<p>10. Wire Rack</p>  <p style="text-align: right;">1 pc</p>	<p>11. Leg tube (body)</p>  <p style="text-align: right;">2 pcs</p>	<p>12. Support plate</p>  <p style="text-align: right;">2 pcs</p>
<p>13. Leg tube (short)</p>  <p style="text-align: right;">2 pcs</p>	<p>14. Leg tube (long)</p>  <p style="text-align: right;">2 pcs</p>	<p>15. Wheels</p>  <p style="text-align: right;">2 pcs</p>	

Stop! DO NOT RETURN TO RETAILER.

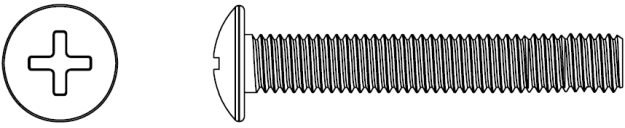
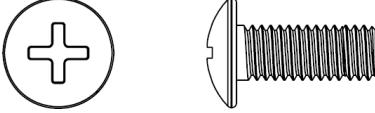
For assembly assistance, missing or damaged parts, please contact Rankam customer service at customerservice@rankam.com or 1-888-837-1380.

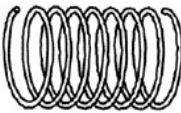
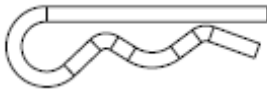
Hardware List

Item	Item name	Diagram	Qty
A	Bolt M6 x 40		12
B	Bolt M6 x 12		15
C	Flange Nut M6		27
D	Spring		1
E	"R" Pin		2
F	M8 Cup Nut		1

Assembly Procedures

Symbol: The following symbols will be shown in each procedure for indication of tightening the bolt and nut if necessary.

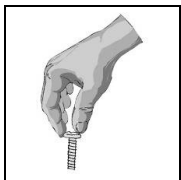

Hand Tighten only at this time

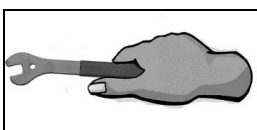

Tighten with tools at this time

Some steps may require the assistance of a friend.

Step 1.

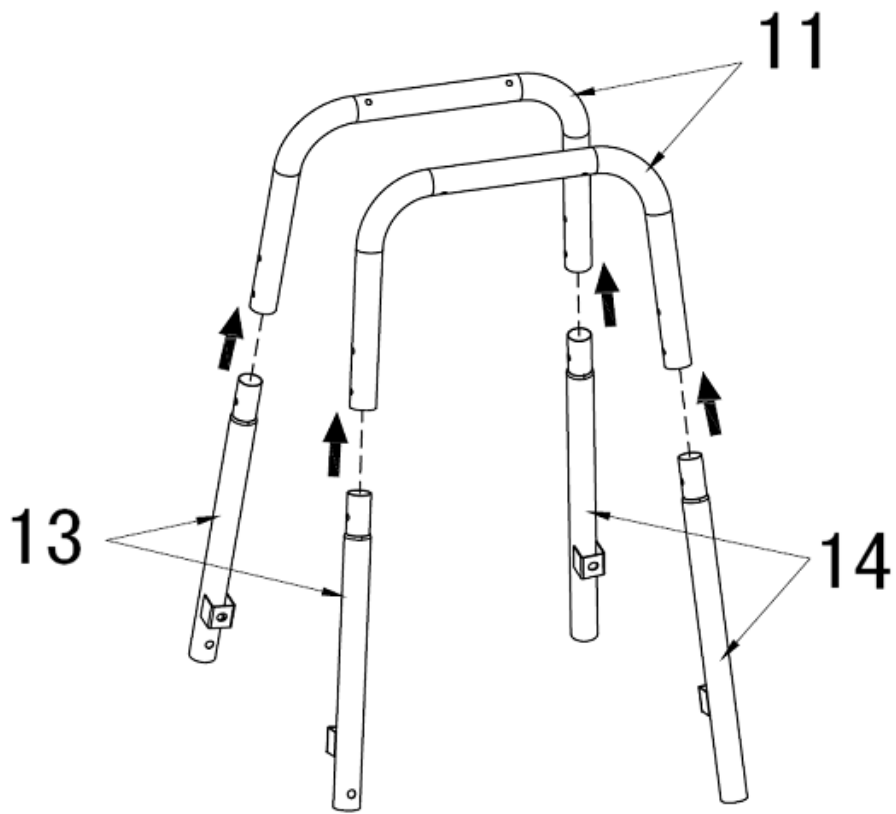

Step 2.

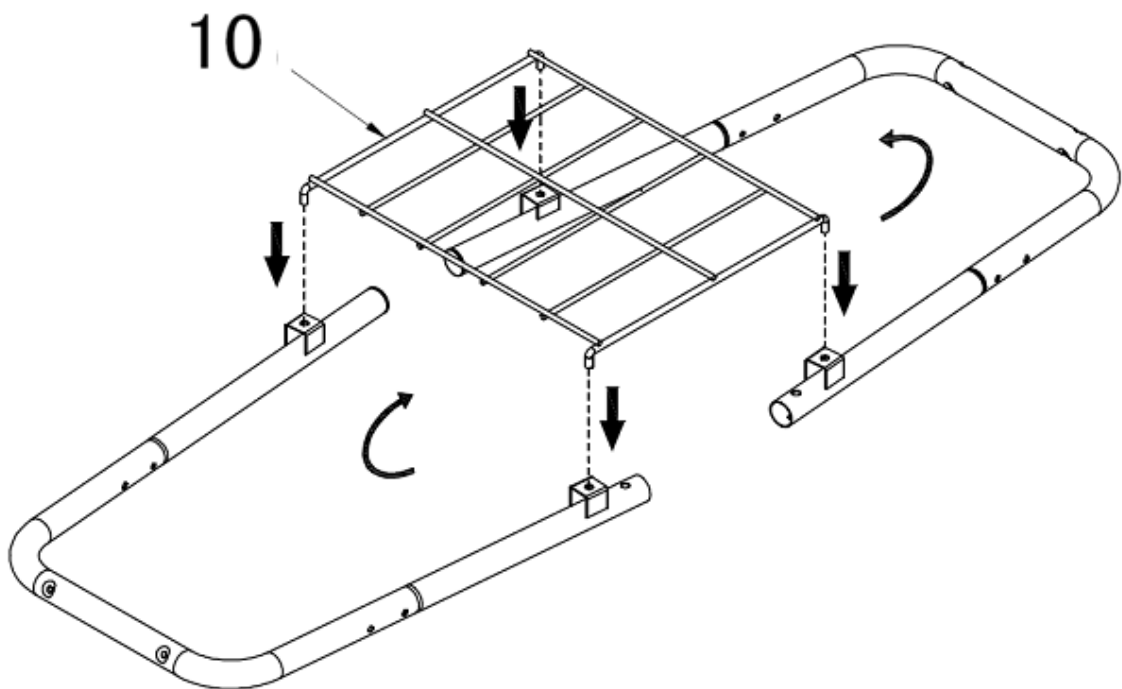

Step 3.

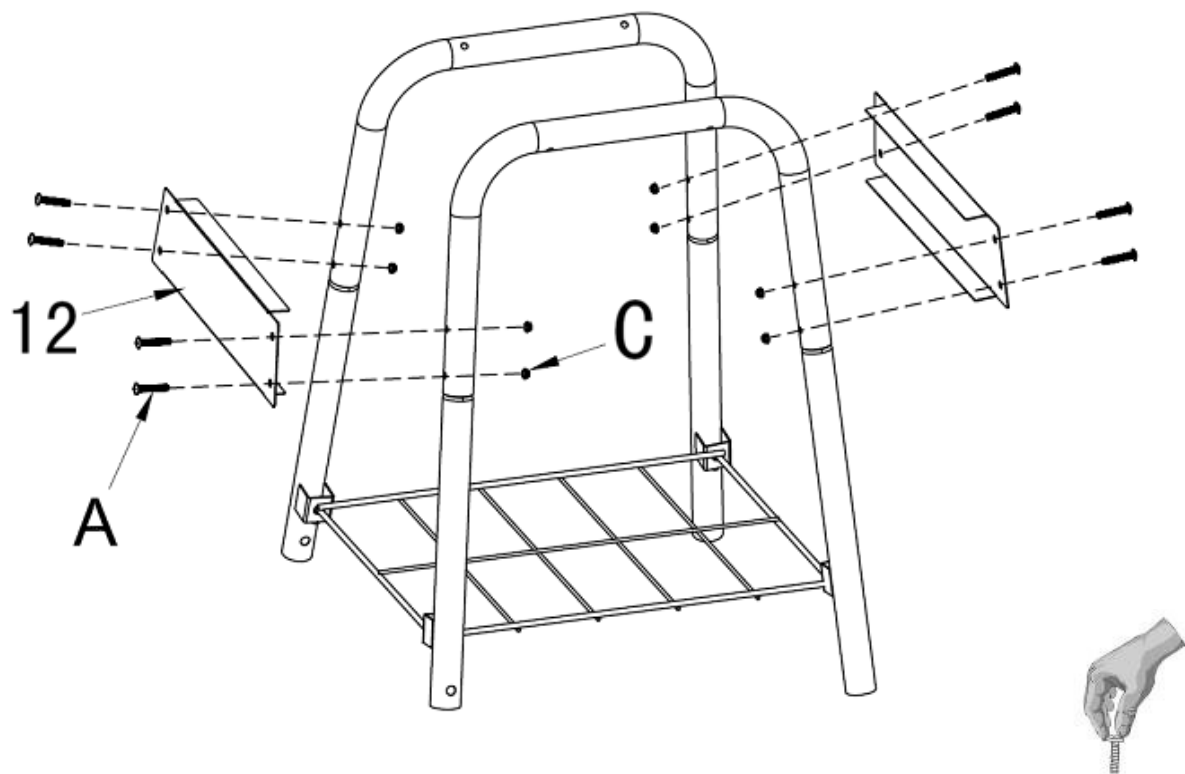

Step 4.

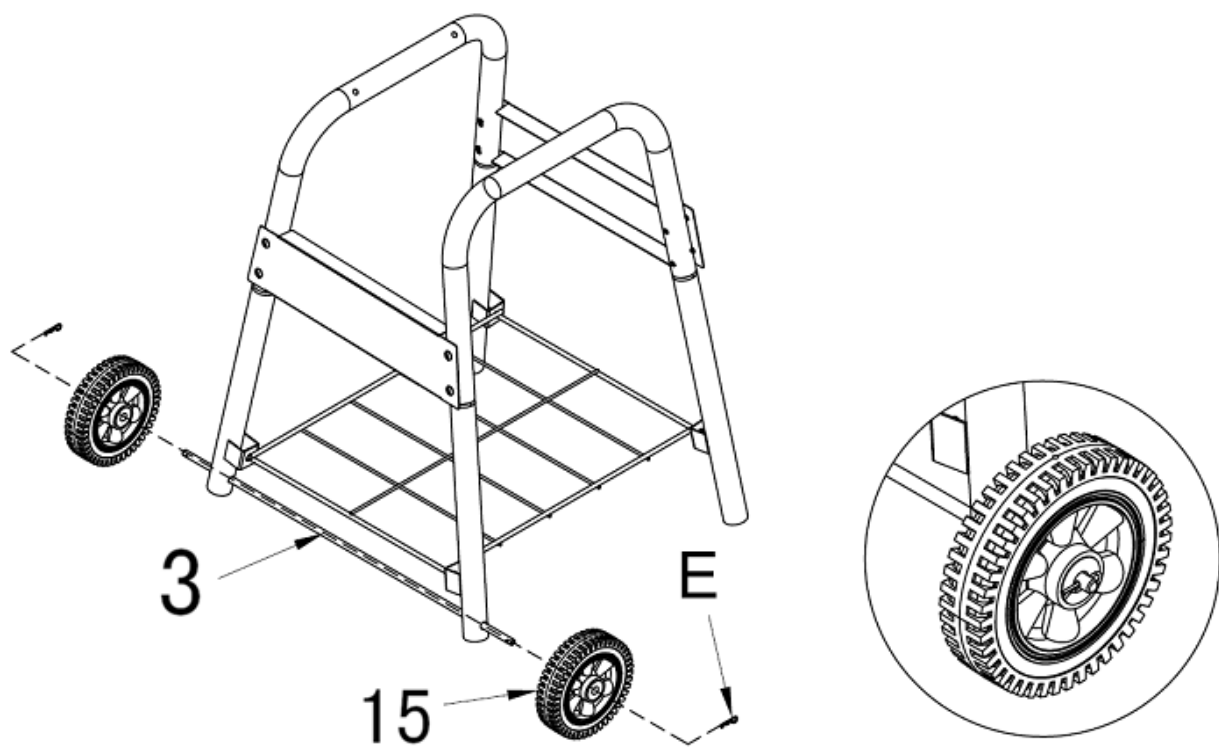

Step 5.

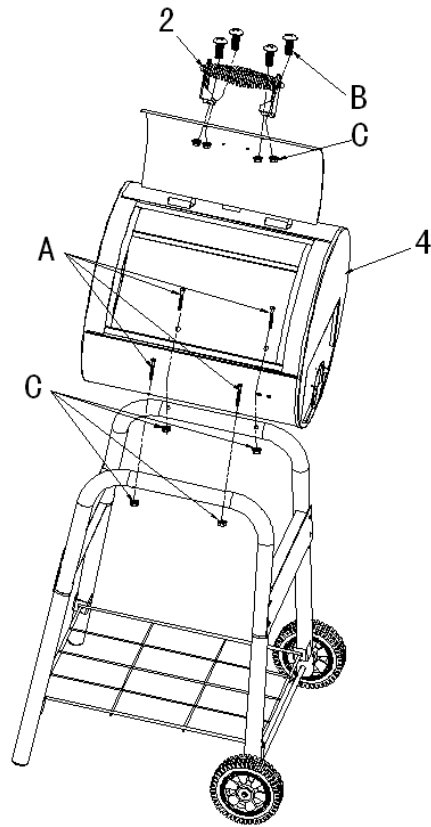

Step 6.

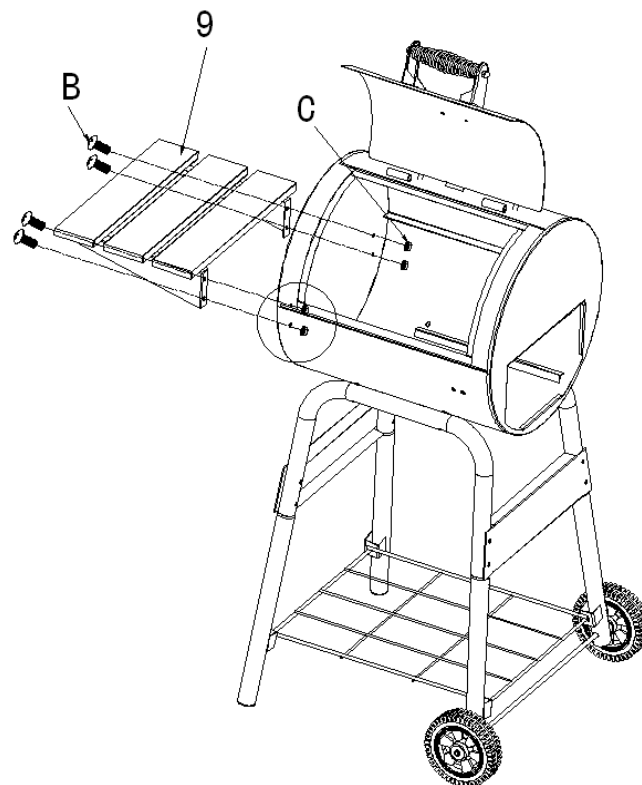

Step 7.

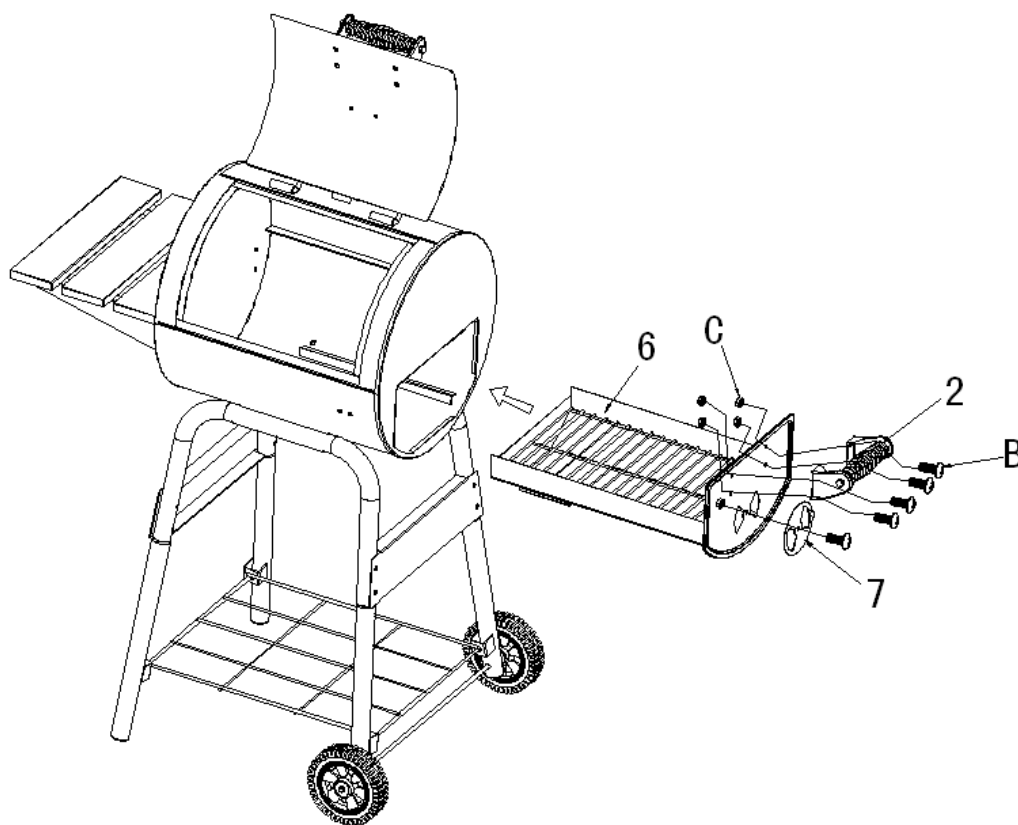

Step 8.

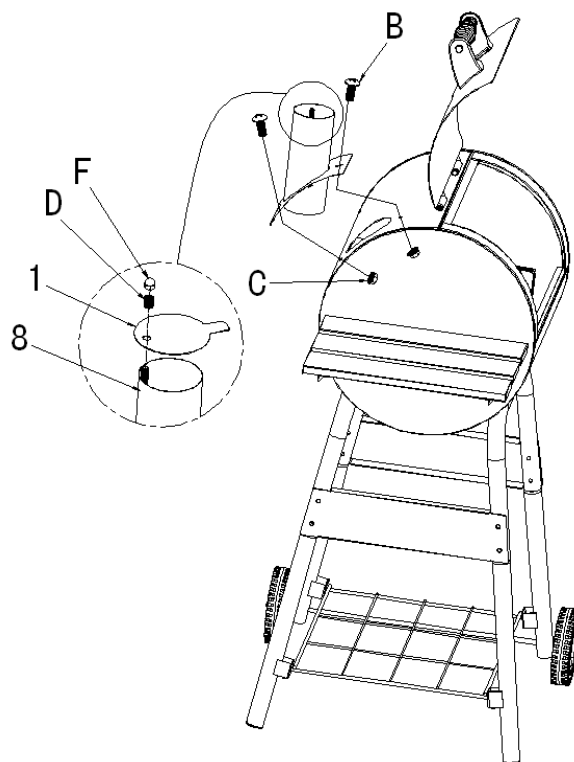

Step 9.

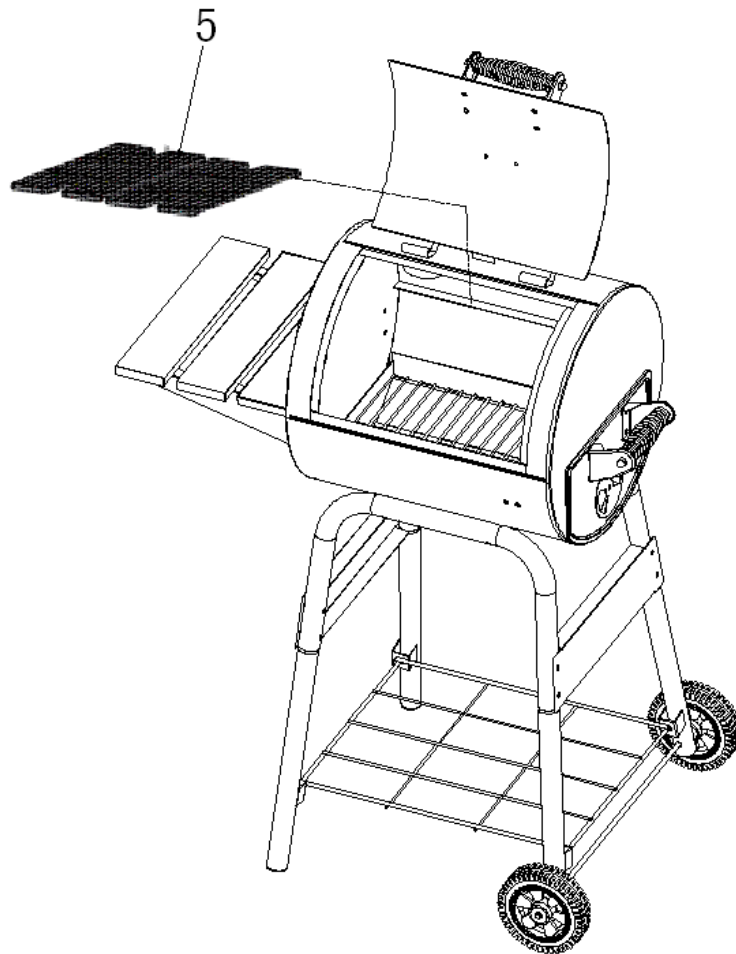

Step 10. Tighten all hardware

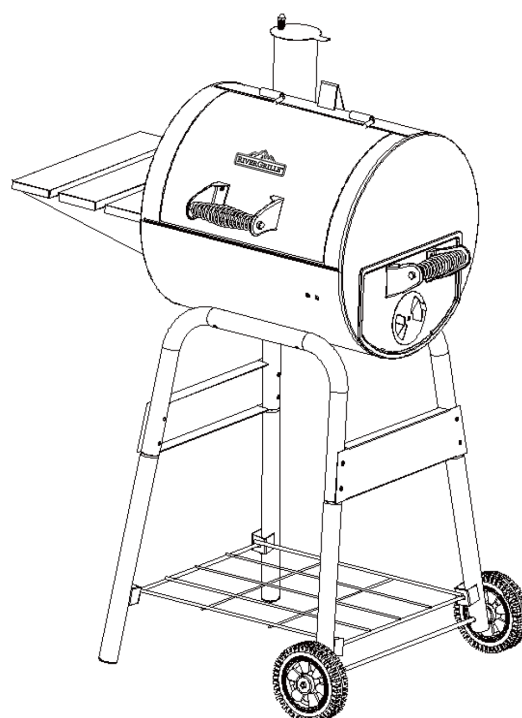



WARNING



DO NOT use grill without charcoal ash pans in place. DO NOT attempt to remove charcoal ash pans while pan contains hot coals.



WARNING



Place the grill **outdoors** on a **hard, level, non-combustible surface** away from roof overhang or any combustible material. **Never use** on wooden or other surfaces that could burn. Place the grill away from open windows or doors to **prevent smoke** from entering your house. In windy weather, place the grill in an outdoor area that is protected from the wind.



WARNING



Read all safety warnings and instructions carefully before operating your grill.

PREPATION FOR USE & LIGHTING INSTRUCTIONS



WARNING



OUTDOOR USE ONLY.

Never use grill indoors. Carbon Monoxide poisoning that can lead to death.

Curing your grill

Prior to your first use of the Grill, follow the instructions below carefully to cure your grill. Curing your grill will minimize damage to the exterior finish as well as get rid of the grill paint odor that can impart unnatural flavours to the first meal prepared on the grill.

IMPORTANT: To protect your grill from excessive rust, the unit must be properly cured and covered at all times when not in use.

Step 1

Lightly coat all interior surfaces of the grill with vegetable oil or vegetable oil spray. Do not coat charcoal grates or racks.

Step 2

Follow the instructions below carefully to build a fire. You may use charcoal and/or wood as fuel in the grill (see "Adding Charcoal/Wood During Cooking" section of this manual).

If using a Charcoal Chimney Starter, follow all manufacturer's warnings and instructions regarding the use of their product. Start with 2.2 lbs (1.0 kg) of charcoal.

Instruction for reference only:

1. Begin with three full sheets of newspaper.
2. Take 2 sheets of newspaper and roll each into a tube shape and then give them a little twist to form each of them into a straight rope like shape. Be careful to not twist too tight.
3. Turn the charcoal chimney starter over and place both pieces of rolled and twisted newspaper along the inside bottom of the charcoal chimney starter to form a complete circle. Leave a hole in the middle of the charcoal chimney starter with no paper in it.
4. Crumple up the third sheet of newspaper into a ball. Be careful to not crumple too tight. Sprinkle about 1 table spoon of cooking oil on the ball of newspaper. You can also use a few sprits of cooking oil from a spray can. Don't use too much oil. Place the ball of cooking-oiled newspaper in the centre of the charcoal chimney starter.
5. Flip the chimney over and add charcoal. Take care so that the newspaper does not fall out.
6. Use a match or long lighter to light the paper.
7. Stand back and watch the charcoal chimney starter do its stuff.
8. After charcoal has turned an ash gray color, carefully pour the charcoal onto your grill's fire grate.

NOTE: To extend the life of your grill, make sure that hot coals and wood do not touch the walls of grill.

IF USING CHARCOAL CHIMNEY STARTER, PROCEED TO STEP 5.

If you choose to use charcoal lighter fluid, ONLY use a product approved for lighting charcoal. Do not use gasoline, kerosene, alcohol or other flammable material for lighting charcoal. Follow all manufacturer's warnings and instructions regarding the use of their product. Start with 2.2 lbs (1.0 kg) of charcoal. Place the charcoal in the centre of each charcoal grate.

Step 3

Saturate charcoal with lighter fluid. With lid open, wait 2 to 3 minutes to allow lighter fluid to soak into charcoal. Store lighter fluid a safe distance from the grill.

Step 4

With grill lid open and charcoal grate completely placed inside the grill, stand back and carefully light charcoal. Allow to burn until covered with a light ash (approximately 20 minutes).



Charcoal lighter fluid must be allowed to completely burn off prior to closing grill lid (approximately 20 minutes). Failure to do this could trap fumes from charcoal lighter fluid in grill and may result in a flash-fire or explosion when lid is opened.

Step 5

With coals burning strong, close the lid. Allow the temperature to reach 107°C (225°F) on the temperature gauge. Maintain this temperature for 2 hours.

Step 6

Increase the temperature to 205°C (400°F) on the temperature gauge. This can be achieved by adding more charcoal and/or wood (see "Adding Charcoal/Wood During Cooking" section of this manual). Maintain this temperature for 1 hour then allow unit to cool completely.

NOTE: It is important that the exterior of the grill is not scraped or rubbed during the curing process.

IMPORTANT: to protect your grill from excessive rust, the unit must be cured periodically and covered at all times when not in use.

OPERATING INSTRUCTIONS

Step 1

Lightly coat all interior surfaces of the grill with vegetable oil or vegetable oil spray. Do not coat charcoal grate or racks.

Step 2

Follow the instructions below carefully to build a fire. You may use charcoal and/or wood as fuel in the Barrel Grill (see "Adding Charcoal/Wood During Cooking" section of this manual).

If using a Charcoal Chimney Starter, follow all manufacturer's warnings and instructions regarding the use of their product. Start with 2.2 lbs (1.0 kg) of charcoal. When charcoal is burning strong, carefully place hot coals in centre of each charcoal grate.

Instruction for reference only:

1. Begin with three full sheets of newspaper.
2. Take 2 sheets of newspaper and roll each into a tube shape and then give them a little twist to form each of them into a straight rope like shape. Be careful to not twist too tight.
3. Turn the charcoal chimney starter over and place both pieces of rolled and twisted newspaper along the inside bottom of the charcoal chimney starter to form a complete circle. Leave a hole in the middle of the charcoal chimney starter with no paper in it.
4. Crumple up the third sheet of newspaper into a ball. Be careful to not crumple too tight. Sprinkle about 1 table spoon of cooking oil on the ball of newspaper. You can also use a few sprits of cooking oil from a spray can. Don't use too much oil. Place the ball of cooking-oiled newspaper in the centre of the charcoal chimney starter.
5. Flip the chimney over and add charcoal. Take care so that the newspaper does not fall out.
6. Use a match or long lighter to light the paper.
7. Stand back and watch the charcoal chimney starter do its stuff.
8. After charcoal has turned an ash gray color, carefully pour the charcoal onto your grill's fire grate.

NOTE: to extend the life of your grill, make sure that hot coals and wood do not touch the walls of grill.

IF USING LIGHTER CHARCOAL CHIMNEY STARTER, PROCEED TO STEP 5.



If you choose to use charcoal lighting fluid, ONLY use a product approved for lighting charcoal. Do not use gasoline, kerosene, alcohol or other flammable materials for lighting charcoal. Follow all manufacturer's warnings and instructions regarding the use of their product. Start with 2.2 lbs (1.0 kg) of charcoal. Place the charcoal in centre of each charcoal grate.

Step 3

Saturate charcoal with lighting fluid. With lid open and charcoal grate completely placed inside the grill, wait 2 to 3 minutes to allow lighter fluid to soak into charcoal. Store charcoal lighter fluid a safe distance from the grill.

Step 4

With grill lid open, stand back and carefully light charcoal and allow to burn until covered with a light ash (approximately 20 minutes).

	<h1>WARNING</h1>	
<p>Charcoal lighting fluid must be allowed to completely burn off prior to closing grill lid (approximately 20 minutes). Failure to do this could trap fumes from charcoal lighting fluid in grill and may result in a flash-fire or explosion when lid is opened.</p>		

Step 5

Place cooking grates on grill support lips.

	<h1>WARNING</h1>	
<p>Always wear oven mitts/gloves when adjusting cooking levels to protect your hands from burns.</p>		

Step 6

Place food on cooking grates and close grill lid. Always use a meat thermometer to ensure food is fully cooked before removing from grill.

Step 7

Allow grill to cool completely, and then follow instructions in the "After-Use Safety" and "Proper Care & Maintenance" sections of this manual.

Flavouring Wood

To obtain your favorite smoke flavour, experiment by using chunks, sticks or chips of flavour-producing wood such as hickory, pecan, apple, cherry, or mesquite. Most fruit or nut tree wood may be used for smoke flavouring. Do not use resinous wood such as pine as it will produce an unpleasant taste.

Wood chunks or sticks 7 to 10 cm (3" to 4") long and 2 to 4 cm (1" to 2") thick work best. Unless the wood is still green, soak the wood in water for 30 minutes or wrap each piece in foil and tear several small holes in the foil to produce more smoke and prevent the wood from burning too quickly. Only a few pieces of wood are required to obtain a good smoke flavour. A recommended amount for the grill is 5 to 6 wood chunks or sticks. Experiment by using more wood for stronger smoke flavour or less wood for milder smoke flavour.

Additional flavouring wood should not have to be added during the cooking process. However, it may be necessary when cooking very large pieces of food. Follow instructions and cautions in the "Adding Charcoal/Wood During Cooking" section of this manual to avoid injury while adding wood.

Regulating Heat

To increase heat, add more wood and/or charcoal. Follow instructions in "Adding Charcoal/Wood During Cooking" section of this manual.

To maintain the temperature, you may need to add more wood and/or charcoal during the cooking cycle.

NOTE: Dry wood burns hotter than charcoal, so you may want to increase the ratio of wood to charcoal to increase the cooking temperature. Hardwood such as oak, hickory, mesquite, fruit and nut wood are an excellent fuel because of their burning rate. When using wood as fuel, make sure the wood is seasoned and dry. **DO NOT** use resinous wood such as pine as it will produce an unpleasant taste.

The amount of food determines the amount of lump charcoal or charcoal briquette to be used. Add charcoal gradually and observe the grilling temperature via the temperature gauge. Adding too much charcoal into the grill at a time may raise the burning temperature rapidly and cause damages to the grill.

Adding Charcoal/Wood During Cooking

Additional charcoal and/or wood may be required to maintain or increase cooking temperature.

Step 1

Stand back and carefully open grill lid. Use caution since flames can flare-up when fresh air suddenly comes in contact with fire.

Step 2

Wearing oven mitts/gloves, lift up the cooking grates and place them on a clean and non-combustible surface. **DO NOT** touch the grates by hand.

Step 3



Stand back a safe distance and use long cooking tongs to lightly brush aside ashes on hot coals. Use cooking tongs to add charcoal and/or wood to charcoal grates, being careful not to stir-up ashes and sparks. If necessary, use your Charcoal Chimney Starter to light additional charcoal and/or wood and add to existing fire.



Step 4

When charcoal is burning strong again, wear oven mitts/gloves and carefully return the charcoal grates to grill body. Extinguish any hot ashes, coals or embers which may have fallen from the grill or beneath and around grill using water hose.

AFTER-USE SAFETY

	<h1>WARNING</h1>	
<ul style="list-style-type: none">● Always allow grill and all components to cool completely before handling.● Never leave coals and ashes in grill unattended. Make sure coals and ashes are completely extinguished before removing.● Before grill can be left unattended, remaining coals and ashes must be removed from grill. Use caution to protect yourself and property. Place remaining coals and ashes in a non-combustible metal container and completely saturate with water. Allow coals and water to remain in metal container 24 hours prior to disposing.● Extinguished coals and ashes should be placed a safe distance from all structures and combustible materials.● With a garden hose, completely wet surface beneath and around the grill to extinguish any ashes, coals or embers which may have fallen during the cooking or cleaning process.● Cover and store grill in a protected area away from children and pets.		

Proper Care & Maintenance

- Cure your grill periodically throughout the year to protect against excessive rust.
- To protect your grill from excessive rust, the unit must be properly cured and covered at all times when not in use.
- Wash cooking grates and charcoal grates with hot, soapy water, rinse well and dry. Lightly coat grates with vegetable oil or vegetable oil spray.
- Clean inside and outside of grill by wiping off with a damp cloth. Apply a light coat of vegetable oil or vegetable oil spray to the interior surface to prevent rusting. Do not coat charcoal grates or racks.
- If rust appears on the exterior surface of your grill, clean and buff the affected area with steel wool or fine grit emery cloth. Touch-up with a good quality high-temperature resistant paint.

Never apply paint to the interior surface. Rust spots on the interior surface can be buffed, cleaned, and then lightly coated with vegetable oil or vegetable oil spray to minimize rusting.

LIMITED WARRANTY

1. Manufacturer warrants this Product to be free from defects in workmanship and materials for a period of Ninety (90) days from the date of purchase, PROVIDED claims are submitted, in writing, with proof of purchase.
2. If any part of this item fails because of a manufacturing defect within the Limited Warranty Period, Manufacturer offers to replace such part(s) provide that such parts have not been improperly repaired, altered, or tampered with or subject to misuse, abuse or exposed to corrosive conditions. This Limited Warranty is, however, subject to certain limitations, exclusions, time limits and exceptions (Hereinafter "Conditions") as listed below. Read these Conditions carefully.
3. This Limited Warranty shall be limited to the replacement or repair of any part(s) which Manufacturer determines, after reasonable examination, to have been defective at the time of manufacturing and manufacturer's obligation(s) shall be limited to replacement, if any, of defective part(s) which shall be shipped at Original Purchaser's expense to Original Purchaser's designated shipping address.
4. This Limited Warranty is given to and covers the **ORIGINAL PURCHASER ONLY** and such coverage terminates Ninety (90) days from the date of purchase.
5. **DAMAGE LIMITATION WARNING:** IN NO EVENT SHALL MANUFACTURER BE LIABLE FOR ANY INCIDENTAL OR CONSEQUENTIAL DAMAGES, INCLUDING (BUT NOT LIMITED TO) LOSS OF USE OF THE PRODUCT, LOSS OF TIME, INCONVENIENCE, EXPENSE FOR TRAVEL, TRANSPORTATION LODGING EXPENSES, LOSS OF FOOD, LOSS BY DAMAGE TO PERSONAL PROPERTY OR LOSS OF INCOME, PROFITS OR REVENUE.
6. **MANUFACTURER'S OBLIGATION:** Manufacturer's liability shall be limited to the delivery of a good, merchantable Product and, if necessary, the repair or replacement, at manufacturer's option, of any defective part or unit.
7. **TRANSFER LIMITATIONS:** This Limited Warranty is not assignable or transferable. It covers only the original purchaser.
8. **RESERVED RIGHT TO CHANGE:** Manufacturer reserves the right to make changes or improvements to products it produces in the future without imposing on itself any obligations to install the same improvements in the products it has previously manufactured.
9. This Limited Warranty gives the Original Purchaser specific legal rights but there may be other rights which vary by jurisdiction.
10. This warranty does not cover the following items:
 - Chips or scratches on porcelain or painted surfaces
 - Rust or corrosion is not deemed a manufacturing or materials defect
 - Discoloration or loss of paint due to handling during assembly, heat or cleaning products. Paint may require touch up.
 - Stainless steel discoloration or corrosion
 - Consumables such as batteries

IF CUSTOMER SERVICE BECOMES NECESSARY:

1. The Original Purchaser is responsible for shipping and handling charges of the returned item(s) and replacement parts, if any.
2. All parts to be replaced will need to be shipped before replacement items will be sent.
3. Follow the Customer Service Representative's instructions exactly. If a return is necessary, it must be packed carefully and shipped prepaid.

Should you encounter any problem

or

Obtaining replacement parts

CALL US FIRST.

Do not return product to the store.

WE CAN HELP.

Rankam (China) Manufacturing Co. Ltd.

**18/F., New Lee Wah Centre,
88 Tokwawan Road,
Kowloon, Hong Kong**

Please contact Rankam Customer Service at customerservice@rankam.com
or at 1-888-837-1380, Mon to Fri, 8:00 a.m. – 5:00 p.m. Pacific Standard Time.