



# Stockade 49" Charcoal Smoker & Grill

## Owner's Manual

### Assembly and Operating Instructions

Model # SC2315801-KF

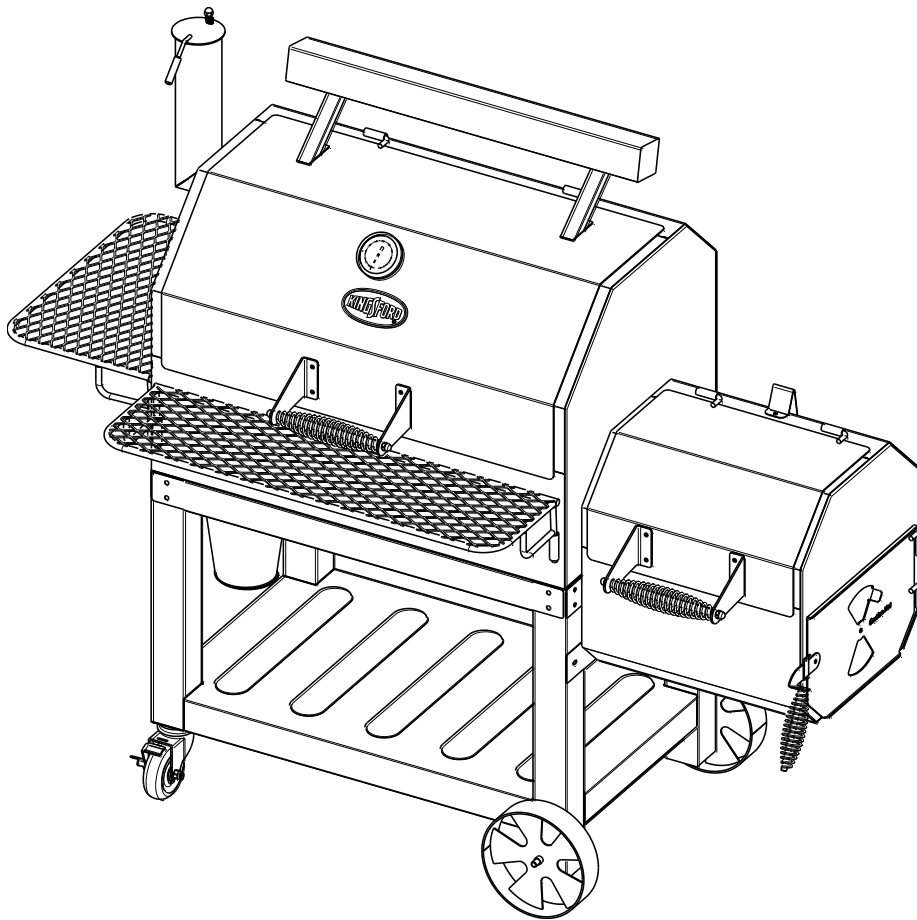

Tools required for assembly: (Not Included) Pliers, Philips & Flathead Screwdrivers, Adjustable Wrench.

Keep this manual for future reference.



# WARNING



- Only use this grill on a hard, level, non-combustible, stable surface (concrete, ground, etc.) capable of supporting the weight of the grill. Never use on wooden or other surfaces that could burn.
  - DO NOT attempt to remove charcoal grate/tray while coals are hot.
  - When grill is in use, keep clearance of 36" between the hot grill and any combustible materials, such as bushes, trees, wooden decks, wooden fences, buildings, etc. Do not place hot grill under roof overhang or in any other enclosed area.
  - For outdoor use only. Do not operate grill indoors or in an enclosed area.
  - For household use only. Do not use this grill for other than its intended purpose.
  - We recommend the use of a Charcoal chimney starter to avoid the dangers associated with charcoal lighting fluid. If you choose to use charcoal lighting fluid, only use lighting fluid approved for lighting charcoal. Carefully read manufacturer's warnings and instructions on the charcoal lighting fluid and charcoal prior to the use of their product. Store charcoal lighting fluid safely away from grill.
  - When using charcoal lighting fluid, allow charcoal to burn with grill lid and doors open until covered with a light ash (approximately 20 minutes). This will allow charcoal lighting fluid to burn off. Failure to do this could trap fumes from charcoal lighting fluid in grill and may result in a flash fire or explosion when lid is opened.
  - Never use charcoal that has been pre-treated with lighting fluid. Use only a high grade plain charcoal or charcoal / wood mixture.
  - Do not use gasoline, kerosene or alcohol for lighting charcoal. Use of any of these or similar products could cause an explosion possibly leading to severe bodily injury.
  - Never add charcoal lighting fluid to hot or even warm coals as flashback may occur causing severe burns.
  - Place grill in an area where children and pets cannot come into contact with unit. Close supervision is necessary when grill is in use.
  - Do not leave grill unattended when in use.
  - When adding charcoal and / or wood, use extreme caution and follow instructions in "Adding Charcoal / Wood During Cooking" section of this manual.
  - Do not store or use grill near gasoline or other flammable liquids, gases or where flammable vapors may be present.
  - Do not store lighter fluid or other flammable liquids or materials under the grill.
  - Use caution when removing charcoal grate/tray, use oven mitt. Handle will be hot when in use.
- Grill is hot when in use. To avoid burns:
- DO NOT attempt to move the grill.
  - Wear protective gloves or oven mitts.
  - DO NOT touch any hot grill surfaces.
  - DO NOT wear loose clothing or allow hair to come in contact with grill.
- When grilling, grease from meat may drip into the charcoal and cause a grease fire. If this should happen close lid to suffocate the flame. Do not use water to extinguish grease fires.
  - Use caution when opening the lid, keep hands, face and body a safe distance away. Flash flare ups may occur when air comes into contact with fire or hot coals.
  - Never place more than 10 pounds on front tables. Do not lean on the front tables.
  - Do not allow charcoal and/or wood to rest on the walls of grill. Doing so will greatly reduce the life if the metal and finish of your grill.



# WARNING



- Use caution during assembly and while operating your grill to avoid scrapes or cuts from sharp edges of metal parts. Wear protective gloves if necessary. Use caution when reaching into or under grill.
- When opening lid, be sure lid is fully opened and secure to prevent lid from closing unexpectedly.
- In windy weather, place grill in an outdoor area that is protected from the wind.
- Close lid to suffocate flame.
- Never leave coals and ashes in grill unattended, before grill can be left unattended, remaining coals and ashes must be removed from grill. Use caution to protect yourself and property, carefully place remaining coals and ashes in a non-combustible metal container and saturate completely with water, allow coals and water to remain in metal container 24 hours prior to disposing.
- Extinguished coals and ashes should be placed a safe distance from all structure and combustible materials.
- With a garden hose completely wet the surface beneath and around grill to extinguish any ashes, coals or embers which may have fallen during the cooking or cleaning process.
- After each use, clean the grill thoroughly and apply a light coat of vegetable oil to prevent rusting. Cover the grill to protect it from excessive rusting.
- Use caution when lifting or moving grill to prevent strains and back injuries.
- We advise that a fire extinguisher be on hand. Refer to your local authority to determine proper size and type of fire extinguisher.
- Store the grill out of reach of children and in a dry location when not in use.
- Do not attempt to services grill other than normal maintenance as explained in “After-Use Safety” and “Proper Care & Maintenance” sections of this manual.
- This unit is heavy! Some assembly steps require more than one person to assemble.
- Properly dispose of all packaging material

Use caution and common sense when operating your grill, Failure to adhere to safety warning and guidelines in this manual could result in bodily injury or property damage. Save this manual for future reference.



**WARNING:** FUELS USED IN WOOD OR CHARCOAL BURNING APPLIANCES, AND THE PRODUCTS OF COMBUSTION OF SUCH FUELS, CAN EXPOSE YOU TO CHEMICALS INCLUDING CARBON BLACK, WHICH IS KNOWN TO THE STATE OF CALIFORNIA TO CAUSE CANCER, AND CARBON MONOXIDE, WHICH IS KNOWN TO THE STATE OF CALIFORNIA TO CAUSE BIRTH DEFECTS OR OTHER REPRODUCTIVE HARM. *For more information go to: [www.P65Warnings.ca.gov](http://www.P65Warnings.ca.gov).*

# ASSEMBLY INSTRUCTIONS

## THANK YOU FOR PURCHASING THIS KINGSFORD STOCKADE 49” CHARCOAL SMOKER & GRILL

Read all safety warnings & assembly instructions carefully before assembling or operating your grill.

For missing parts, please contact customer service at [customerservice@rankam.com](mailto:customerservice@rankam.com) or at 888-837-1380 (U.S. only), Mon to Fri, 8:00 a.m. – 5:00 p.m. Pacific Standard Time.

(Proof of purchase will be required.)

Inspect contents of the box to ensure all parts are included and undamaged.

We recommend two people for assembly of this grill.

The following tools are required for assembly and are not included:

- Pliers
- Philips & Flathead Screwdrivers
- Adjustable Wrench

**Symbol:** The following symbols will be shown in each procedure for indication of tightening the bolt and nut if necessary.

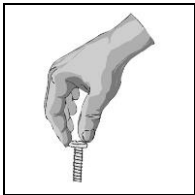

**Hand Tighten only at this time**

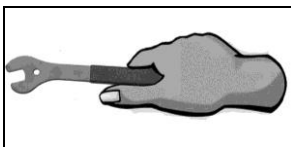

**Tighten with tools at this time**

**Some steps may require the assistance of a friend**





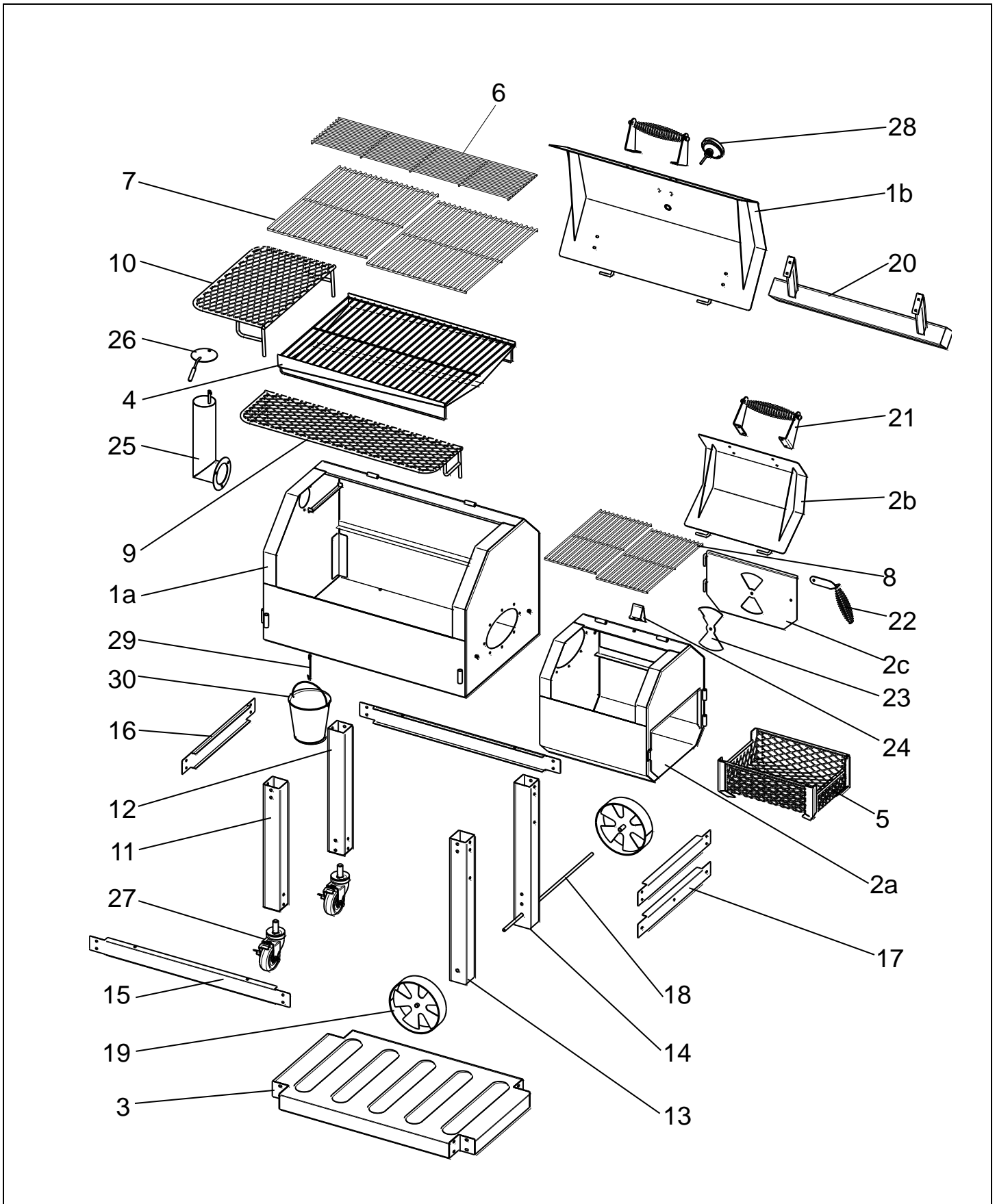

Hold lid firmly when taking parts out of grill body. Some parts are heavy.

# Product Diagram

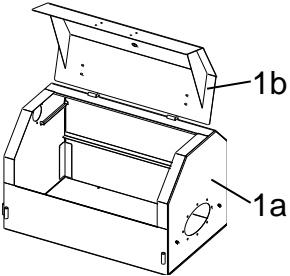
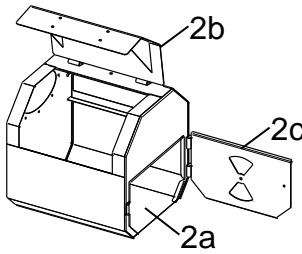
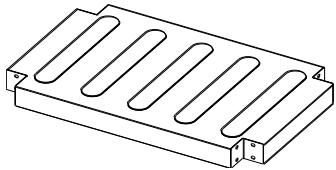
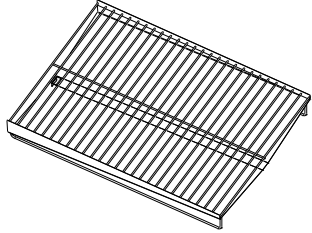
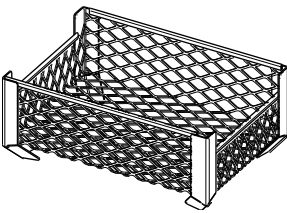
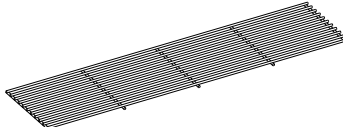
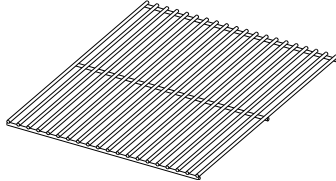
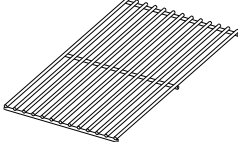
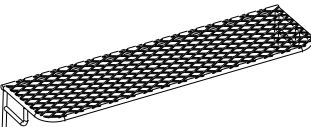
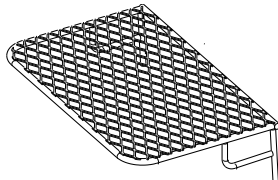
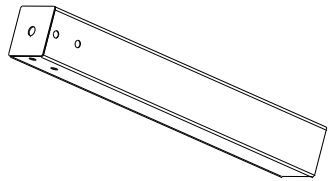
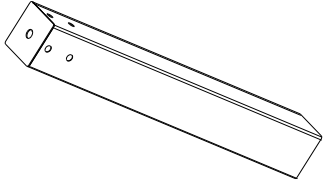
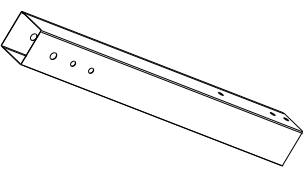
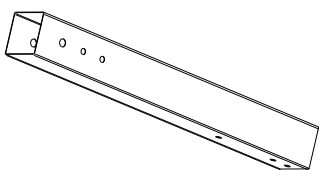
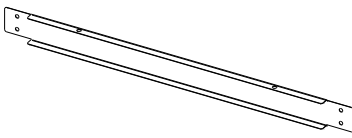
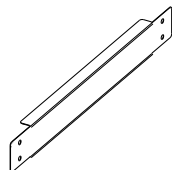
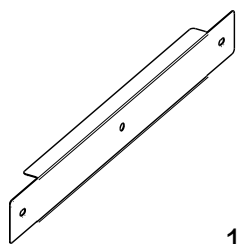
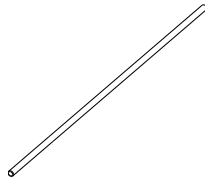
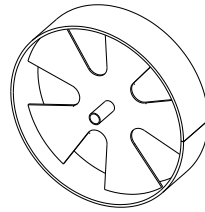
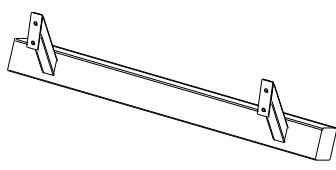

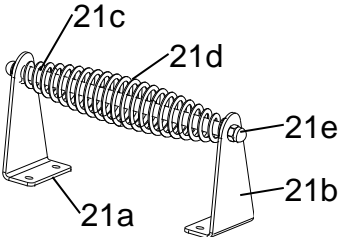
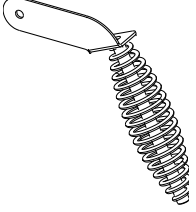
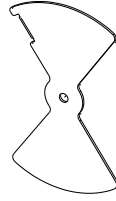

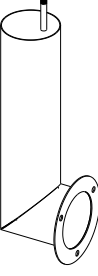
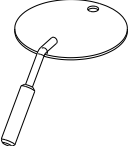
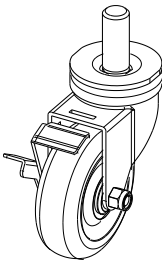
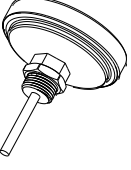

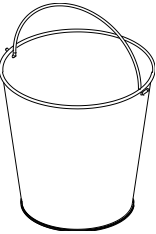
# Component List

1. Main Chamber	2. Offset Firebox	3. Bottom Storage	4. Charcoal Grate/Pan
 <p>1 pc</p>	 <p>1 pc</p>	 <p>1 pc</p>	 <p>1 pc</p>
5. Charcoal Basket	6. Warming Rack	7. Main Chamber Cooking Grate	8. Offset Firebox Cooking Grate
 <p>1 pc</p>	 <p>1 pc</p>	 <p>2 pcs</p>	 <p>2 pcs</p>
9. Front Table	10. Side Table	11. Left Front Leg	12. Left Rear Leg
 <p>1 pc</p>	 <p>1 pc</p>	 <p>1 pc</p>	 <p>1 pc</p>
13. Right Front Leg	14. Right Rear Leg	15. Cart Panel - Long	16. Cart Panel - Short
 <p>1 pc</p>	 <p>1 pc</p>	 <p>2 pcs</p>	 <p>2 pcs</p>
17. Firebox Bracket	18. Wheel Axle	19. Wheel	20. Lid Weight Bar
 <p>1 pc</p>	 <p>1 pc</p>	 <p>2 pcs</p>	 <p>1 pc</p>

21. Lid Handle	22. Side Door Handle	23. Offset Firebox Vent	24. Lid Bracket
 <p>21c 21d 21e 21a 21b</p> <p>2 pcs</p>	 <p>1 pc</p>	 <p>1 pc</p>	 <p>1 pc</p>
25. Smoke Stack	26. Smoke Stack Lid	27. Caster	28. Temp Gauge
 <p>1 pc</p>	 <p>1 pc</p>	 <p>2 pcs</p>	 <p>1 pc</p>
29. Hook	30. Grease Bucket	.	
 <p>1 pc</p>	 <p>1 pc</p>		

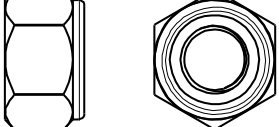
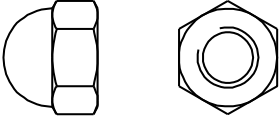
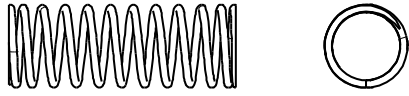
## Hardware List

Item No.	Item name	Diagram	Qty
A	Bolt M6x15		68
B	Flange Nut M6		21
C	Lock Nut M6		2
D	Lock Nut M10		2
E	Cap Nut M8		1
F	Coil Spring		1
G	Spring Washer ID6		2

For assembly assistance, missing or damaged parts, please contact customer service at [customerservice@rankam.com](mailto:customerservice@rankam.com) or at 888-837-1380

**DO NOT RETURN TO RETAILER**



## Assembly Procedures

Step 1. Turn Bottom Storage (#3) upside down and then attach Legs (#11,12,13,14). **Hand Tighten Bolts Only** in this step

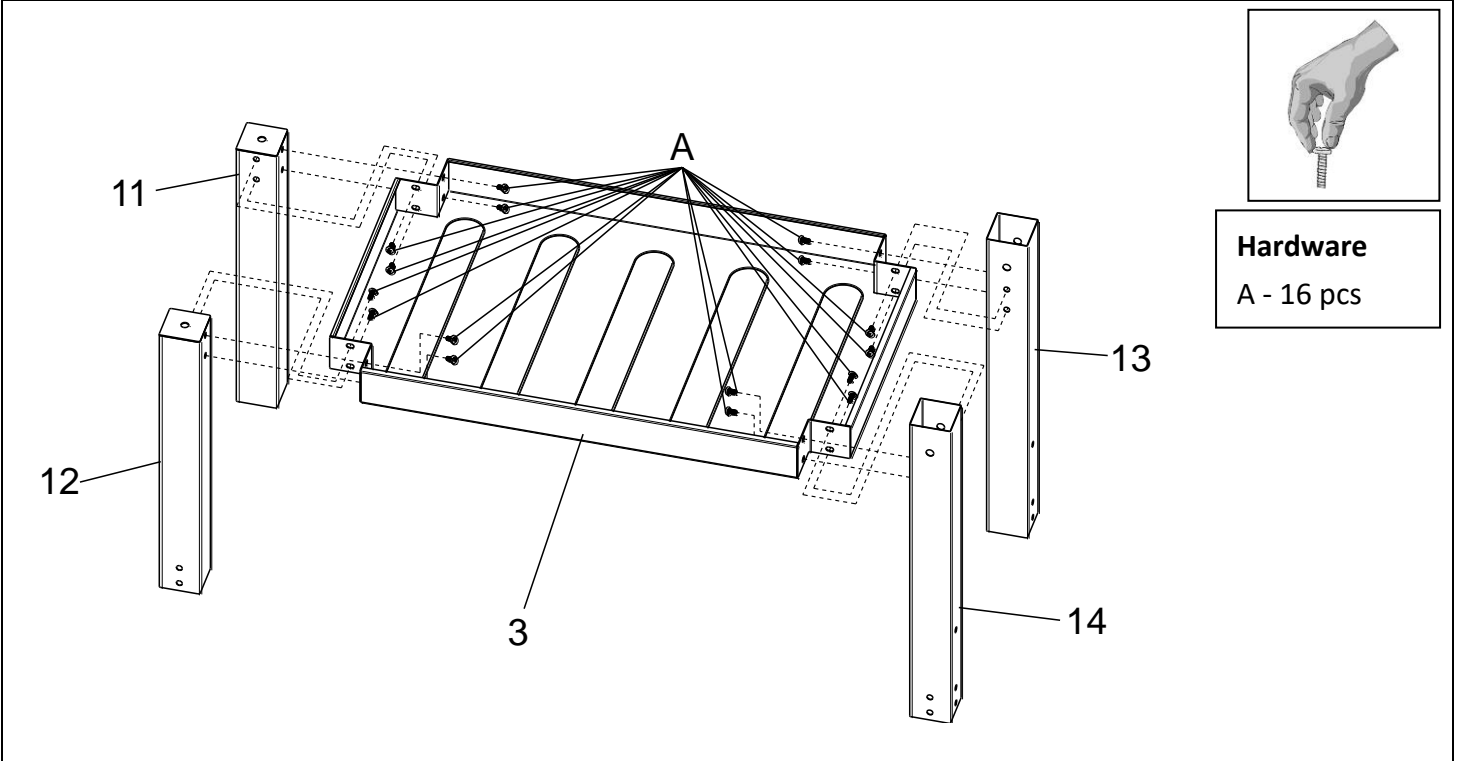

Step 2. Attach Casters (#27), Wheel Axle (#18) and Wheels (#19) to Bottom Storage (#3)

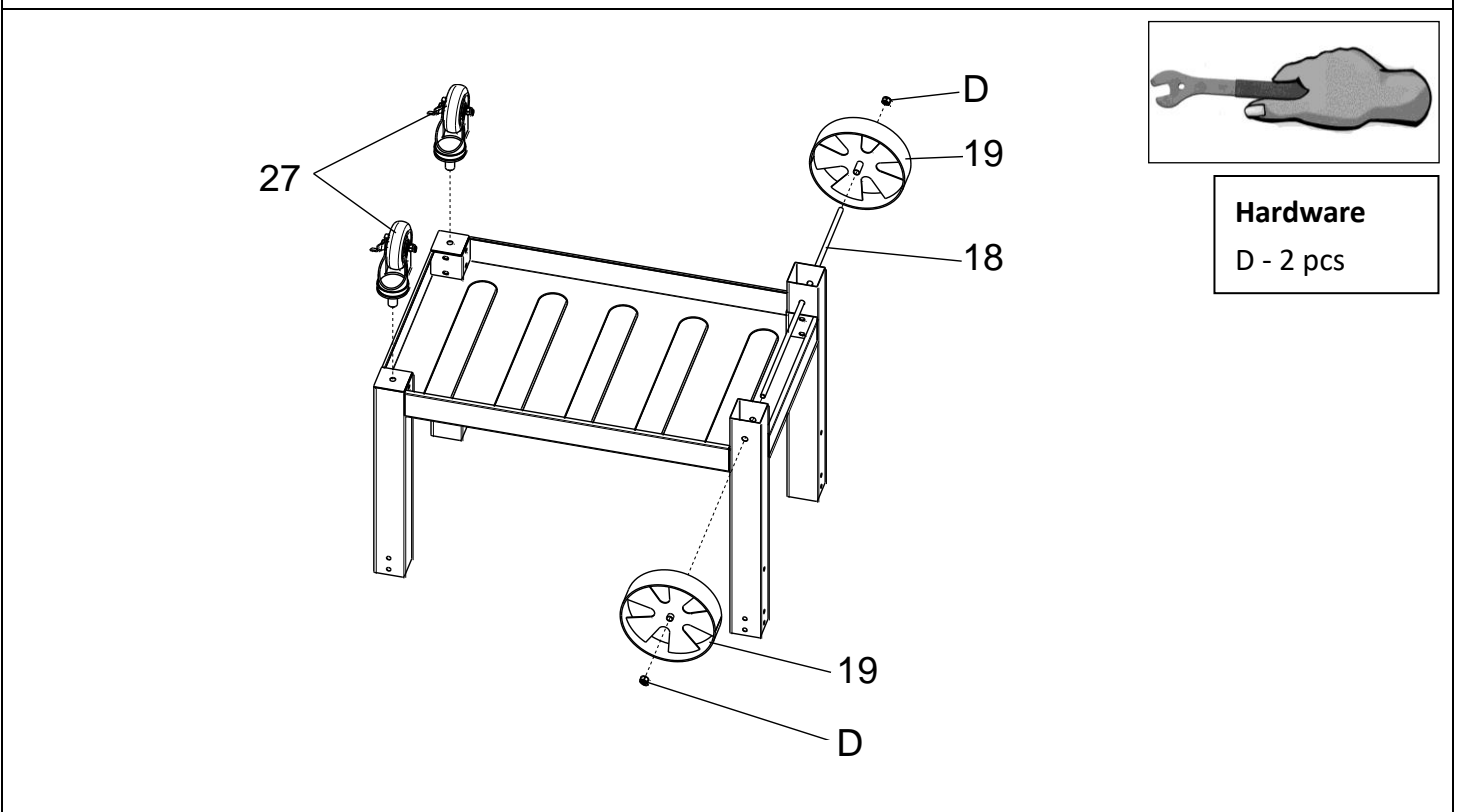

Step 3. Flip over cart assembly in last step. Attach Cart Panels (#15,16) and Firebox Bracket (#17).

**Tighten bolts in step #1 and in this step**

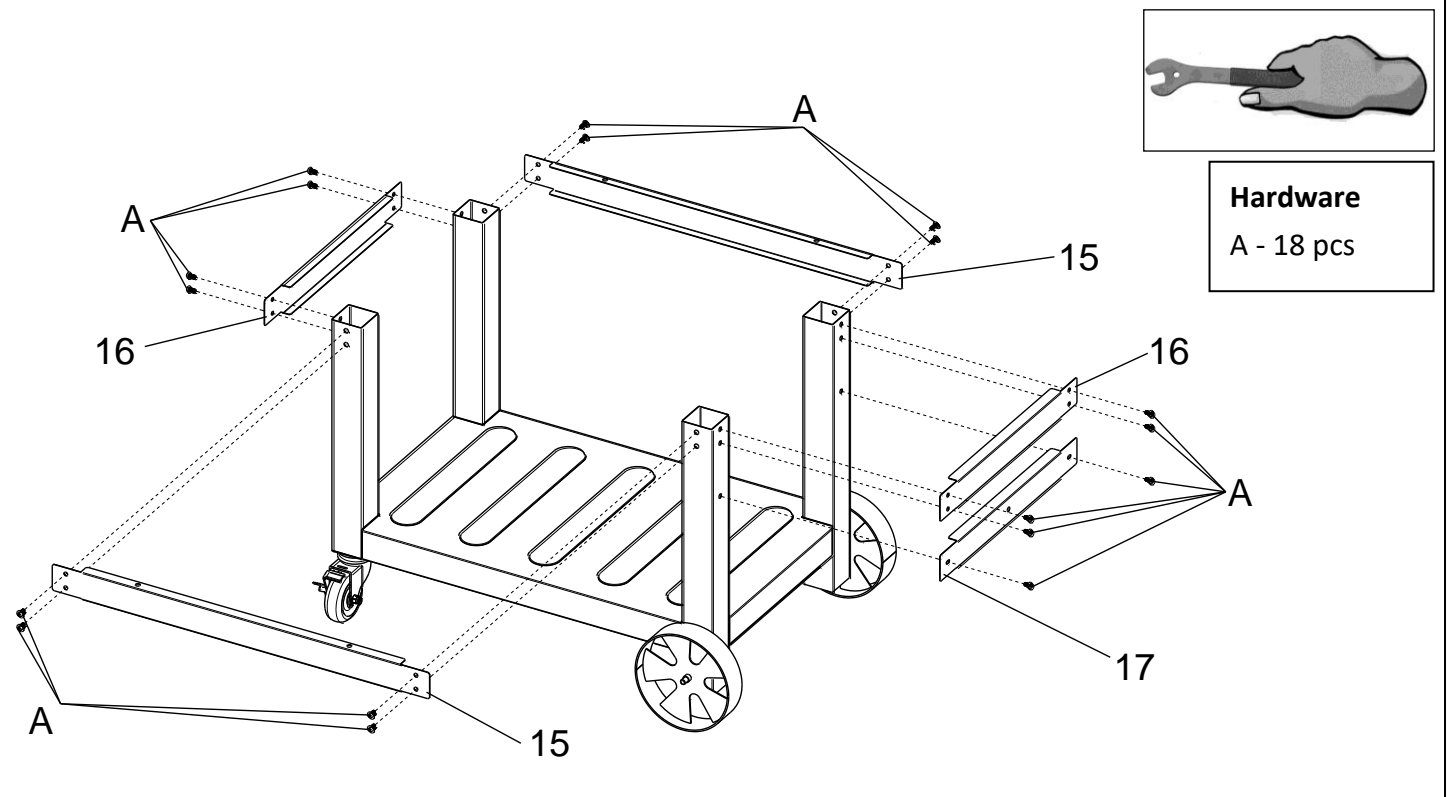

Step 4. Attach Lid Handle (#21), Lid Weight Bar (#20) and Temperature Gauge (#28) to Main Chamber (#1)

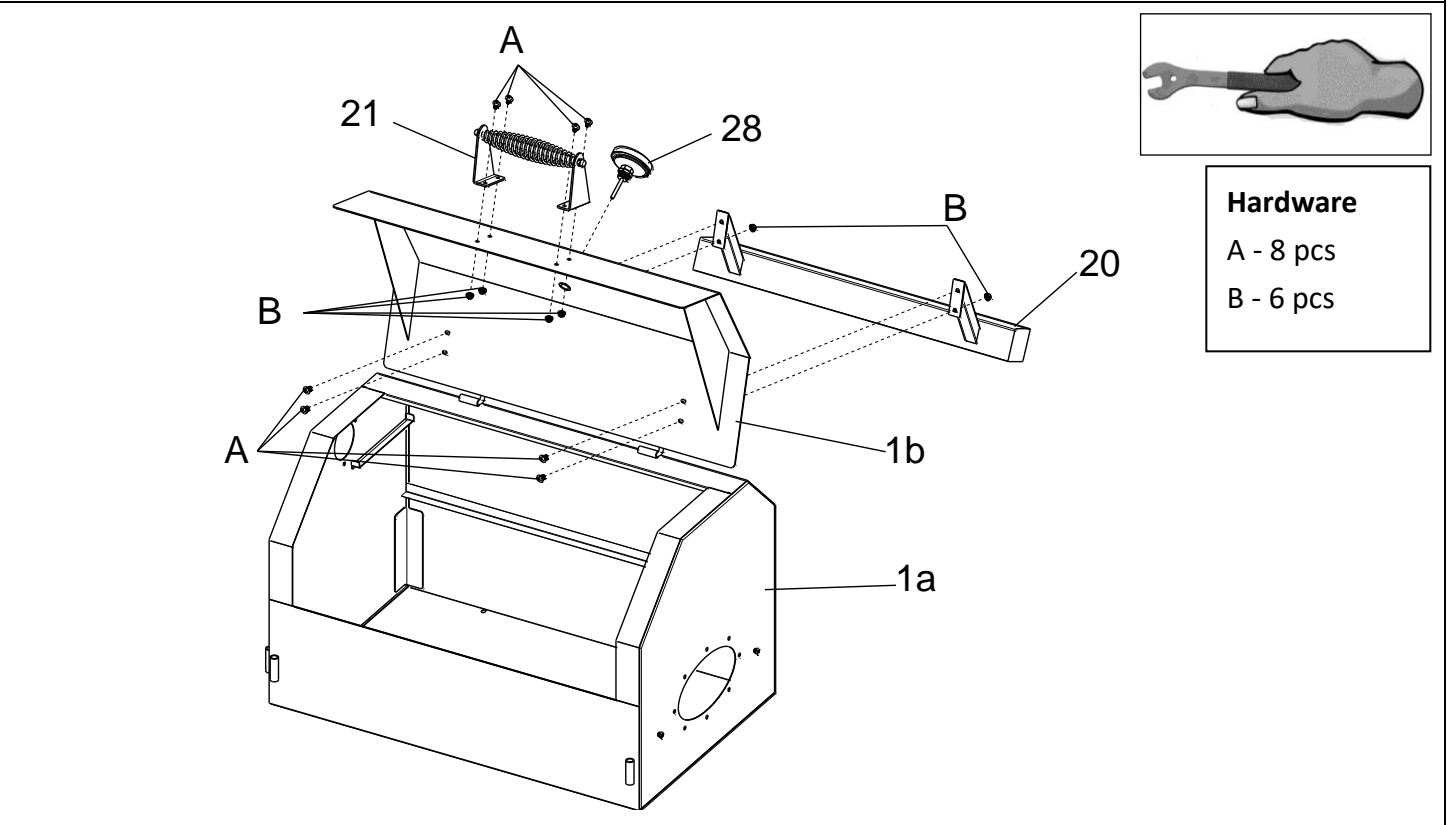

Step 5. Attach Main Chamber (#1) to Cart Assembly

**Warning:**

Have 2 adults to assemble in this step. The main chamber is heavy. Lock the casters to prevent cart from moving. One person holds the main chamber body and lid firmly. Another person secures bolts.

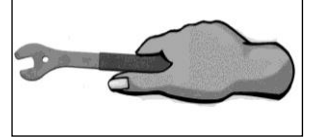
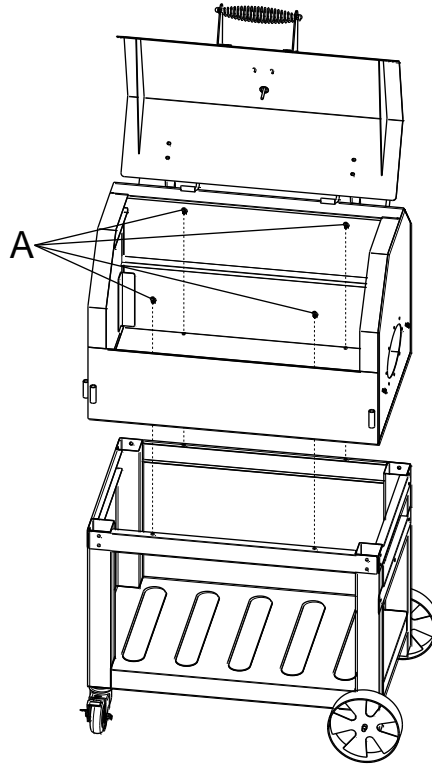

**Hardware**

A - 4 pcs

Step 6. Attach Lid Handle (#21), Side Door Handle (#22) and Offset Firebox Vent (#23) to Offset Firebox (#2)

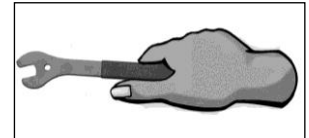
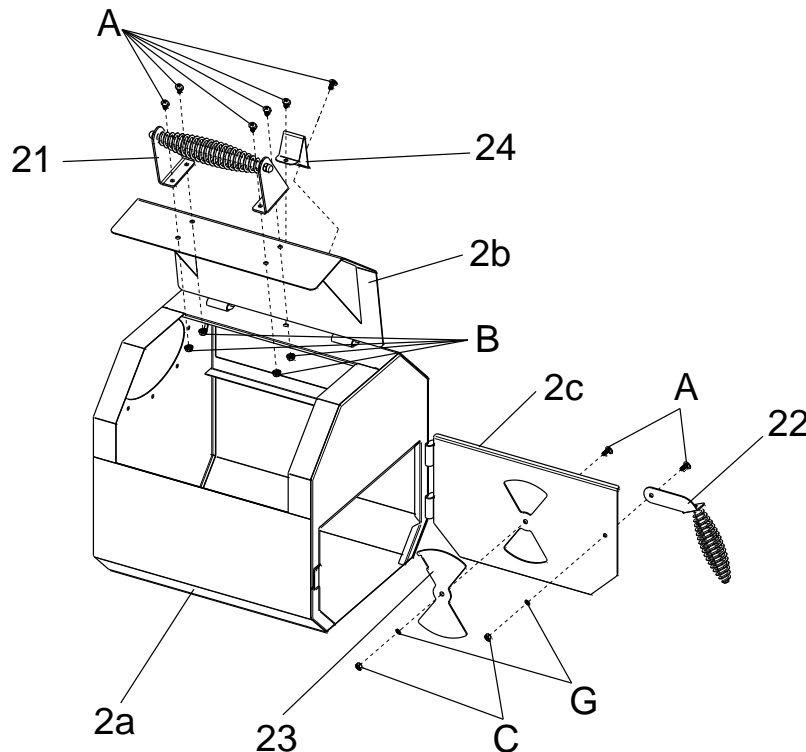

**Hardware**

A - 8 pcs

B - 4 pcs

C - 2 pcs

G - 2 pcs

Step 7. Attach Offset Firebox (#2) to Main chamber (#1)

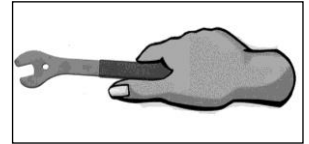

**Hardware**

A - 11 pcs

B - 8 pcs

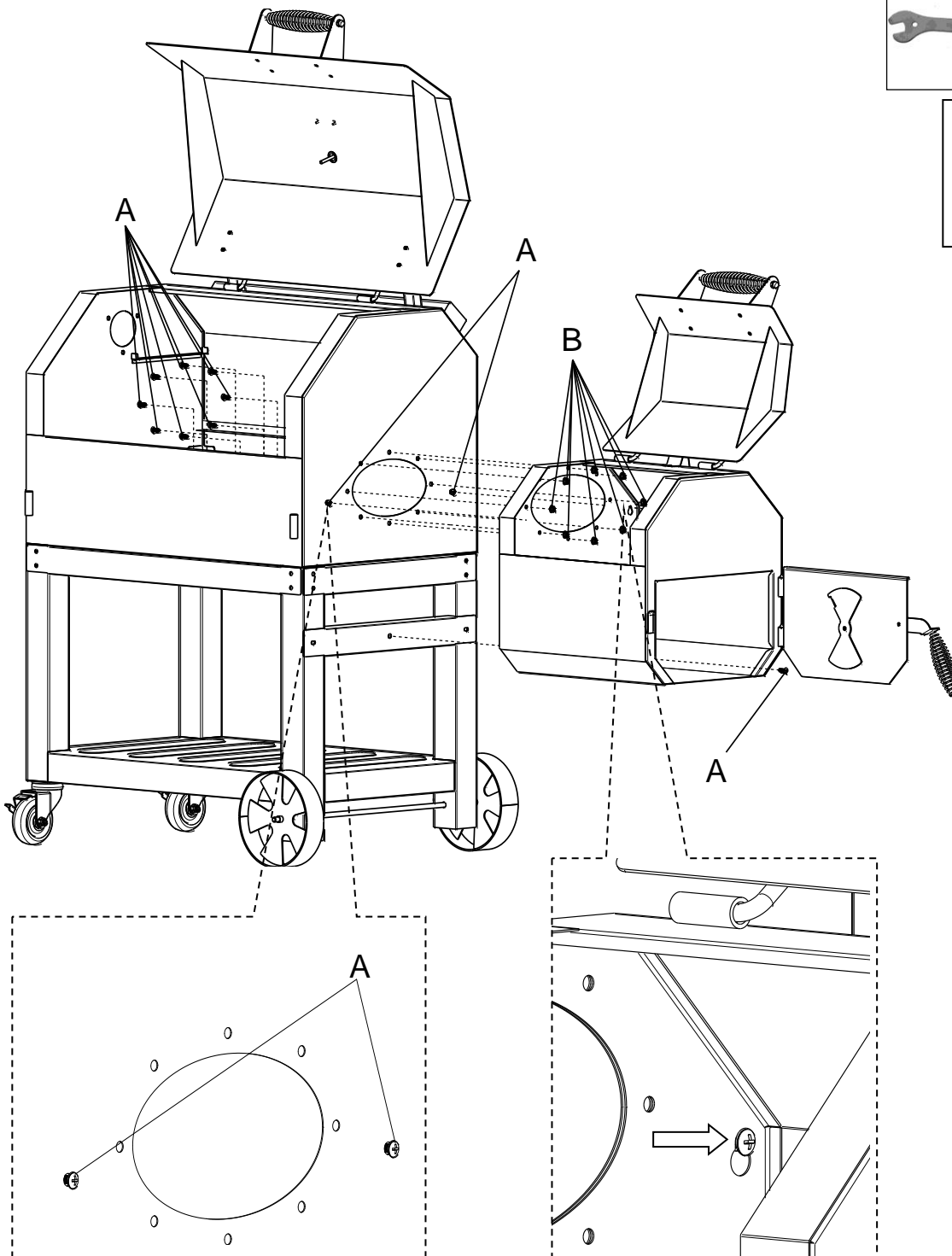

Tips: Attach these 2 bolts first and hang offset firebox to main chamber. Then continue on attaching rest of bolts

Step 8. Attach Smoke Stack and Lid (#25,26) to Main Chamber

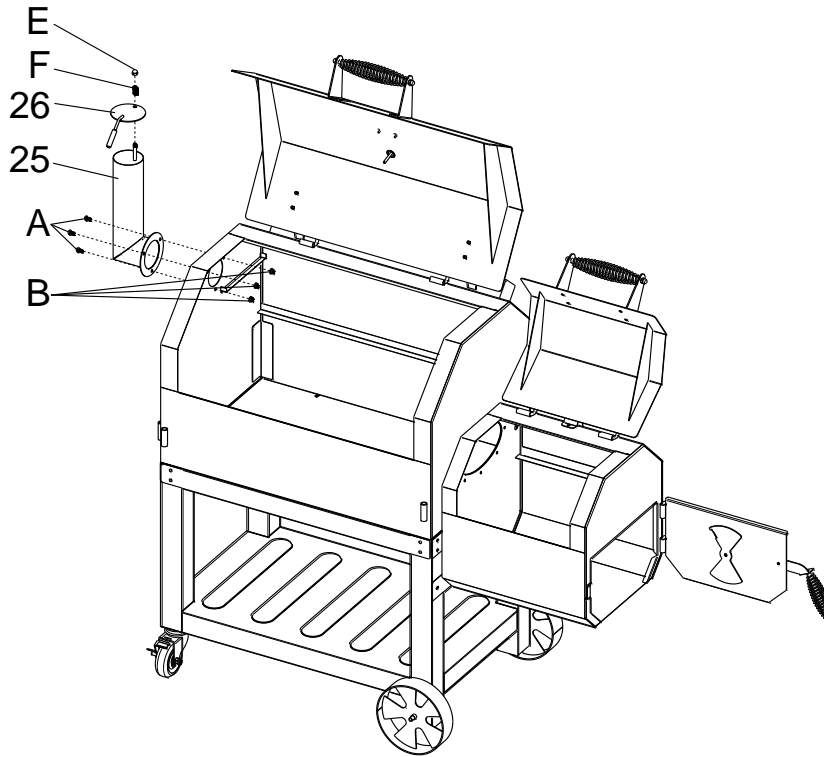

**Hardware**

A - 3 pcs

B - 3 pcs

E - 1 pc

F - 1 pc

Step 9. Place Charcoal Grate/Pan (#4) and Charcoal Basket (#5) into Smoker/Grill

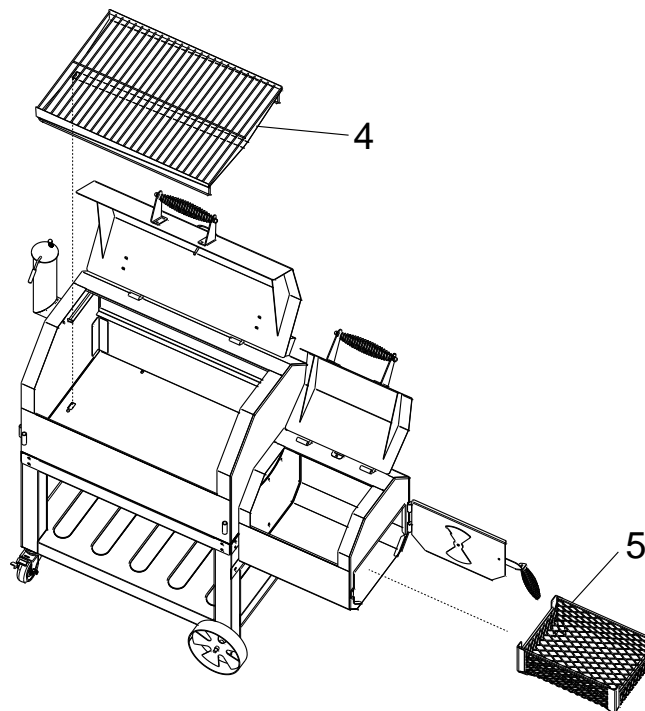

Step 10. Place Cooking Grates (#7,8) into Smoker/Grill

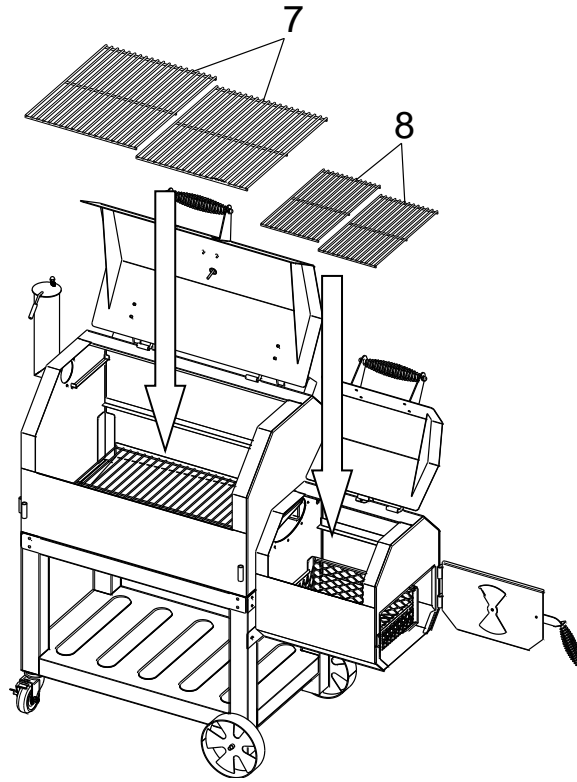

Step 11. Place Warming Rack (#6), Front and Side Tables (#9,10) onto Smoker/Grill

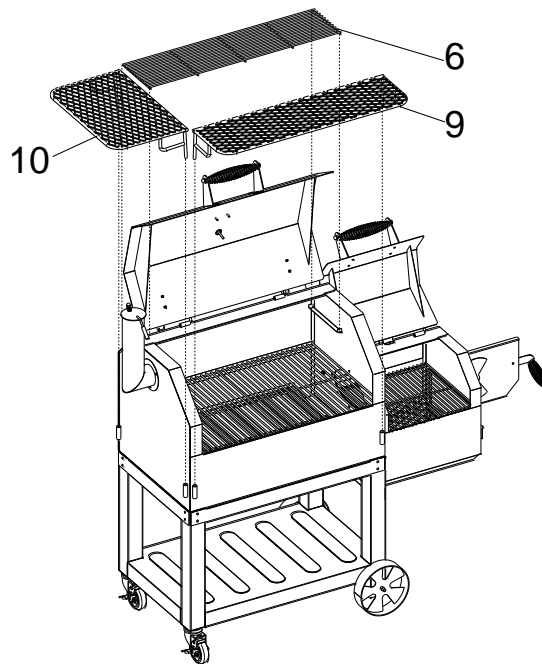

Step 12. Hang Hook (#29) and Grease Bucket (#30) to Smoker/Grill.

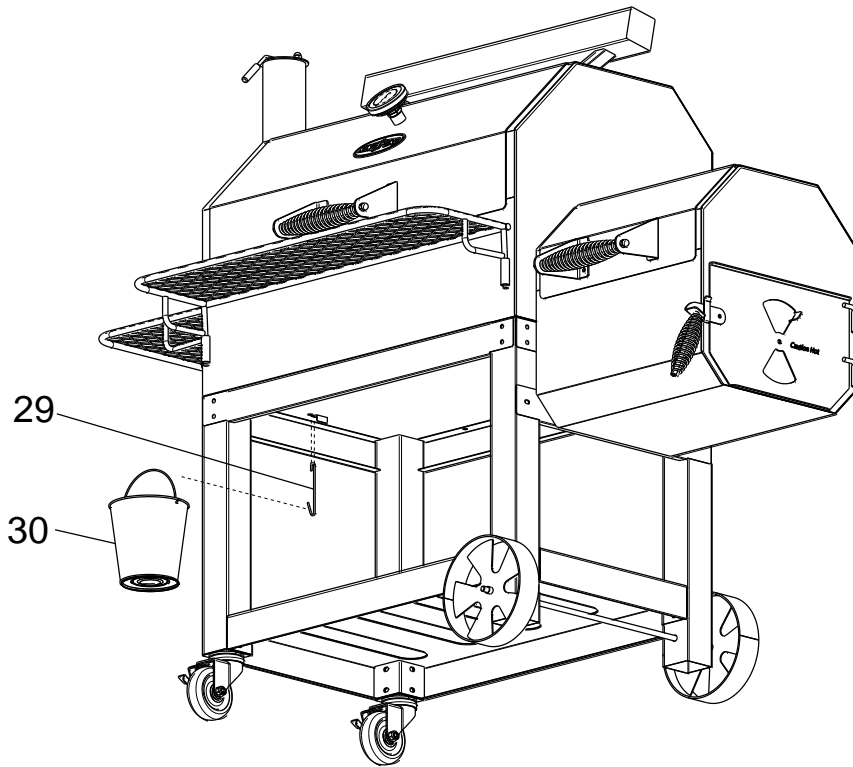

**Assembly is now completed. Make sure all bolts and nuts are tightened before use.**



## **WARNING**

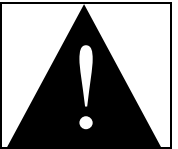

Place the grill outdoors on a hard, level, non-combustible surface away from roof overhang or any combustible material. Never use on wooden or other surfaces that could burn. Place the grill away from open windows or doors to prevent smoke from entering your house. In windy weather, place the grill in an outdoor area that is protected from the wind.

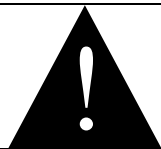

## **WARNING**

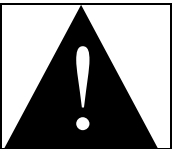

Read all safety warnings and instructions carefully before operating your grill.

## **PREPARATION FOR USE & LIGHTING INSTRUCTIONS**

## Curing your grill

Prior to your first use of the grill, follow the instructions below carefully to cure your grill. Curing your grill will minimize damage to the exterior finish as well as get rid of the grill paint odor that can cause unnatural flavors to the first meal prepared on the grill.



**IMPORTANT: To protect your grill from excessive rust, the unit must be properly cured and covered at all times when not in use.**

### Step 1

Lightly coat all interior surfaces of the grill with vegetable oil or vegetable oil spray. **Do not coat** charcoal grate, grids or charcoal ash tray.

### Step 2

Follow the instructions below carefully to build a fire. You may use charcoal and/or wood as fuel in the grill (see "Adding Charcoal/Wood During Cooking" section of this manual).

	<h1>WARNING</h1>	
<p>Never use charcoal that has been pre-treated with lighter fluid. Use only a high grade plain charcoal or charcoal /wood mixture.</p>		

If using a Charcoal Chimney Starter, follow all manufacturer's warnings and instructions regarding the use of their product. Start with 3 pounds of charcoal. When charcoal is burning strong, carefully place hot coals on charcoal grate of main chamber.

**NOTE: To extend the life of your grill, make sure that hot coals and wood do not touch the walls of grill.**

### IF USING CHARCOAL CHIMNEY STARTER, PROCEED TO STEP 5.



If you choose to use charcoal lighting fluid, ONLY use charcoal lighting fluid approved for lighting charcoal. Do not use gasoline, kerosene, alcohol or other flammable material for lighting charcoal. Follow all manufacturer's warnings and instructions regarding the use of their product. Start with 3 pounds of charcoal and place charcoal in the center of charcoal grate of main chamber.

### Step 3

Saturate charcoal with lighting fluid. With lid open, wait 2 to 3 minutes to allow lighting fluid to soak into charcoal. Store lighting fluid a safe distance from the grill.

### Step 4

With grill lid open and charcoal grate/tray completely placed inside the grill. Stand back and carefully light charcoal. Allow to burn until covered with a light ash (approximately 20 minutes).

	<h1>WARNING</h1>	
<p>Charcoal lighting fluid must be allowed to completely burn off prior to closing grill lid (approximately 20 minutes). Failure to do this could trap fumes from charcoal lighting fluid in grill and may result in a flash-fire or explosion when lid is opened.</p>		

### Step 5

With coals burning strong, close the lid. Allow the temperature to reach 225°F (107°C). Maintain this temperature for 2 hours.



### Step 6

Increase the temperature to 400°F (205°C). This can be achieved by adding more charcoal and/or wood (see “Adding Charcoal/Wood During Cooking” section of this manual). Maintain this temperature for 1 hour then allow unit to cool completely.

**NOTE:** It is important that the exterior of the grill is not scraped or rubbed during the curing process.

**IMPORTANT:** to protect your smoker from excessive rust, the unit must be cured periodically and covered at all times when not in use.

## OPERATING INSTRUCTIONS

### Step 1

Lightly coat all interior surfaces of the grill with vegetable oil or vegetable oil spray. **Do not coat** charcoal grate, grids.

### Step 2

Follow the instructions below carefully to build a fire. You may use charcoal and/or wood as fuel in the grill (see “Adding Charcoal/Wood During Cooking” section of this manual).

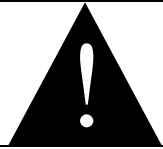
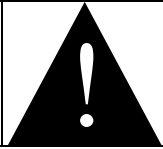
	<h1>WARNING</h1>	
<p>Never use charcoal that has been pre-treated with lighter fluid. Use only a high grade plain charcoal or charcoal/wood mixture.</p>		

If using a Charcoal Chimney Starter, follow all manufacturer’s warnings and instructions regarding the use of their product. Start with 3 pounds of charcoal. When charcoal is burning strong, carefully place hot coals in center of charcoal grate of main chamber.

\*If using offset firebox for food smoking, start with 2 pounds of charcoal. Place hot coals into charcoal basket of offset firebox.

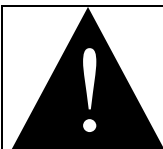
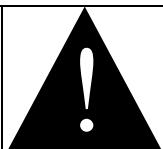
	<h1>WARNING</h1>	
<p>DO NOT use grill without charcoal grate/tray in place. DO NOT attempt to remove charcoal grate while grate/tray contains hot coals.</p>		

**NOTE:** to extend the life of your grill, make sure that hot coals and wood do not touch the walls of grill.

### IF USING CHARCOAL CHIMNEY STARTER, PROCEED TO STEP 5.

If you choose to use charcoal lighting fluid, ONLY use charcoal lighting fluid approved for lighting charcoal. Do not use gasoline, kerosene, alcohol or other flammable materials for lighting charcoal. Follow all manufacturer’s warnings and instructions regarding the use of their product. Start with 3 pounds of charcoal. Place the charcoal in center of charcoal grate of main chamber.

### Step 3

Saturate charcoal with lighting fluid. With lid open and charcoal tray completely placed inside the grill, wait 2 to 3 minutes to allow lighting fluid to soak into charcoal. Store charcoal lighting fluid a safe distance from the grill.

### Step 4

With grill lid open, stand back and carefully light charcoal and allow to burn until covered with a light ash (approximately 20 minutes).

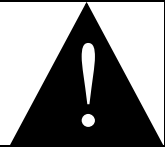

# WARNING



Charcoal lighting fluid must be allowed to completely burn off prior to closing grill lid (approximately 20 minutes). Failure to do this could trap fumes from charcoal lighting fluid in grill and may result in a flash-fire or explosion when lid is opened.

## Step 5

Place cooking grates on grill support lips.

## Step 6

Place food on cooking grates and close grill lid. Always use a meat thermometer to ensure food is fully cooked before removing from grill.

## Step 7

Allow grill to cool completely, and then follow instructions in the “After-Use Safety” and “Proper Care & Maintenance” sections of this manual.

## Flavoring Wood

To obtain your favorite smoke flavor, experiment by using chunks, sticks or chips of flavor producing wood such as hickory, pecan, apple, cherry, or mesquite. Most fruit or nut tree wood may be used for smoke flavoring. Do not use resinous wood such as pine as it will produce an unpleasant taste.

Wood chunks or sticks 3” to 4” (7 to 10 cm) long and 1” to 2” (2 to 4 cm) thick work best. Unless the wood is still green, soak the wood in water for 30 minutes or wrap each piece in foil and tear several small holes in the foil to produce more smoke and prevent the wood from burning too quickly. Only a few pieces of wood are required to obtain a good smoke flavor. A recommended amount for the grill is 5 to 6 wood chunks or sticks. Experiment by using more wood for stronger smoke flavor or less wood for milder smoke flavor.

Additional flavoring wood should not have to be added during the cooking process. However, it may be necessary when cooking very large pieces of food. Follow instructions and cautions in the “Adding Charcoal/Wood During Cooking” section of this manual to avoid injury while adding wood.

## Regulating Heat

To increase heat, add more wood and/or charcoal. Follow instructions in “Adding Charcoal/Wood During Cooking” section of this manual.

To maintain the temperature, you may need to add more wood and/or charcoal during the cooking cycle.

**NOTE:** Dry wood burns hotter than charcoal, so you may want to increase the ratio of wood to charcoal to increase the cooking temperature. Hardwood such as oak, hickory, mesquite, fruit and nut wood are an excellent fuel because of their burning rate. When using wood as fuel, make sure the wood is seasoned and dry. **DO NOT** use resinous wood such as pine as it will produce an unpleasant taste.

The amount of food determines the amount of lump charcoal or charcoal briquette to be used. Add charcoal gradually and observe the grilling temperature via the temperature gauge. Adding too much charcoal into the grill at a time may raise the burning temperature rapidly and cause damages to the grill.

## Adding Charcoal/Wood During Cooking

Additional charcoal and/or wood may be required to maintain or increase cooking temperature.

### Step 1

Stand back and carefully open grill lid. Use caution since flames can flare-up when fresh air suddenly comes in contact with fire.

**Step 2**

Wearing oven mitts/gloves to take out charcoal grate and place it on a clean and non-combustible surface. DO NOT touch the charcoal grate by hand.

**Step 3**

Stand back a safe distance and use long cooking tongs to lightly brush aside ashes on hot coals. Use cooking tongs to add charcoal and/or wood to charcoal grate, being careful not to stir-up ashes and sparks. If necessary, use your Charcoal Chimney Starter to light additional charcoal and/or wood and add to existing fire.

	<h1>WARNING</h1>	
<p>Never add charcoal lighting fluid to hot or even warm coals as flashback may occur causing severe burns.</p>		

**Step 4**

When charcoal is burning strong again, wear oven mitts/gloves and carefully the return charcoal grate to grill body. Extinguish any hot ashes, coals or embers which may have fallen from the grill or beneath and around grill.

## Smoking Tips - Meat Smoking using Offset Firebox

Meat smoking is best in the range 225-240°F. Stabilize the smoker temperature by using optimum amount of charcoal in offset firebox in conjunction with control of air flow through air vent on offset firebox door and smoke stack.

Smoking time is relevant to size, thickness and muscle/fat ratio of meats. *Be sure to use food thermometer to check when the meat is done.*

<i>USDA Recommended Safe Minimum Internal Temperature</i>	
Pork chops, Ribs & Roasts	145° F
Beef, Lamb, Veal Steaks & Roasts	145° F
Fish	145° F
Ground Beef, Pork, Veal & Lamb	160° F
Ground Turkey & Chicken Stuffing & Casseroles	165° F
Chicken & Turkey Breasts	165° F
Poultry Legs, Thighs & Wings	165° F
Chicken, Whole	165° F
Turkey, Whole	165° F

This information is for quick reference. Always check up-to-date information at [www.isitdoneyet.gov](http://www.isitdoneyet.gov)

## AFTER-USE SAFETY

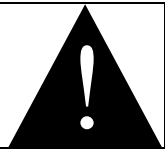

# WARNING



- Always allow grill and all components to cool completely before handling.
- Never leave coals and ashes in grill unattended. Make sure coals and ashes are completely extinguished before removing.
- Before grill can be left unattended, remaining coals and ashes must be removed from grill. Use caution to protect yourself and property. Place remaining coals and ashes in a non-combustible metal container and completely saturate with water. Allow coals and water to remain in metal container 24 hours prior to disposing.
- Extinguished coals and ashes should be placed a safe distance from all structures and combustible materials.
- With a garden hose, completely wet surface beneath and around the grill to extinguish any ashes, coals or embers which may have fallen during the cooking or cleaning process.
- Cover and store grill in a protected area away from children and pets.

## Proper Care & Maintenance

- Cure your grill periodically throughout the year to protect against excessive rust.
- To protect your grill from excessive rust, the unit must be properly cured and covered at all times when not in use.
- Wash cooking grates and charcoal tray with hot, soapy water, rinse well and dry. Lightly coat grates with vegetable oil or vegetable oil spray.
- Clean inside and outside of grill by wiping off with a damp cloth. Apply a light coat of vegetable oil or vegetable oil spray to the interior surface to prevent rusting. Do not coat charcoal tray.
- If rust appears on the exterior surface of your grill, clean and buff the affected area with steel wool or fine grit emery cloth. Touch-up with a good quality high-temperature resistant paint.
- Never apply paint to the interior surface. Rust spots on the interior surface can be buffed, cleaned, and then lightly coated with vegetable oil or vegetable oil spray to minimize rusting.

## LIMITED WARRANTY

1. Manufacturer warrants this Product to be free from defects in workmanship and materials for a period of one year from the date of purchase, PROVIDED claims are submitted, in writing, with proof of purchase.
2. If any part of this item fails because of a manufacturing defect within the Limited Warranty Period, Manufacturer offers to replace such part(s) provide that such parts have not been improperly repaired, altered, or tampered with or subject to misuse, abuse or exposed to corrosive conditions. This Limited Warranty is, however, subject to certain limitations, exclusions, time limits and exceptions (Hereinafter "Conditions") as listed below. Read these Conditions carefully.
3. This Limited Warranty shall be limited to the replacement or repair of any part(s) which Manufacturer determines, after reasonable examination, to have been defective at the time of manufacturing and manufacturer's obligation(s) shall be limited to replacement, if any, of defective part(s) which shall be shipped at Original Purchaser's expense to Original Purchaser's designated shipping address.
4. This Limited Warranty is given to and covers the **ORIGINAL PURCHASER ONLY** and such coverage terminates one year from the date of purchase.
5. **DAMAGE LIMITATION WARNING:** IN NO EVENT SHALL MANUFACTURER BE LIABLE FOR ANY INCIDENTAL OR CONSEQUENTIAL DAMAGES, INCLUDING (BUT NOT LIMITED TO) LOSS OF USE OF THE PRODUCT, LOSS OF TIME, INCONVENIENCE, EXPENSES FOR TRAVEL, TRANSPORTATION, LODGING EXPENSES, LOSS OF FOOD, LOSS BY DAMAGE TO PERSONAL PROPERTY OR LOSS OF INCOME, PROFITS OR REVENUE.
6. **MANUFACTURER'S OBLIGATION:** Manufacturer's liability shall be limited to the delivery of a good, merchantable Product and, if necessary, the repair or replacement, at manufacturer's option, of any defective part or unit.
7. **TRANSFER LIMITATIONS:** This Limited Warranty is not assignable or transferable. It covers only the original purchaser.
8. **RESERVED RIGHT TO CHANGE:** Manufacturer reserves the right to make changes or improvements to products it produces in the future without imposing on itself any obligations to install the same improvements in the products it has previously manufactured.
9. This Limited Warranty gives the Original Purchaser specific legal rights but there may be other rights which vary by jurisdiction.
10. This warranty does not cover the following items:
  - Chips or scratches on porcelain or painted surfaces
  - Rust or corrosion is not deemed a manufacturing or materials defect
  - Discoloration or loss of paint due to handling during assembly, heat or cleaning products. Paint may require touch up.
  - Stainless steel discoloration or corrosion

### **IF CUSTOMER SERVICE IS NECESSARY:**

1. The Original Purchaser is responsible for shipping and handling charges of the returned item(s) and replacement parts, if any.
2. All parts to be replaced will need to be shipped before replacement items will be sent.
3. Follow the Customer Service Representative's instructions exactly. If a return is necessary, it must be packed carefully and shipped prepaid.

# Optional Custom Cover Available

Please visit [www.homedepot.com](http://www.homedepot.com) for more information

Model #: **AC2323001-YY**  
**Stockade 49 Inch Grill Cover**



Should you encounter any problem  
or  
Obtaining replacement parts

**CALL US FIRST**

Do not return product to the store

**WE CAN HELP**

**Rankam (China) Manufacturing Co. Ltd.**

18/F., New Lee Wah Centre, 88 Tokwawan Road, Kowloon, Hong Kong

**Please contact Customer Service at:**

[customerservice@rankam.com](mailto:customerservice@rankam.com)

or at

1 – 888 – 837 – 1380

Hours of Operation: 8:00am – 5:00pm Pacific Standard Time

MADE IN CHINA