

This Owner's Manual is provided and hosted by [Appliance Factory Parts](#).

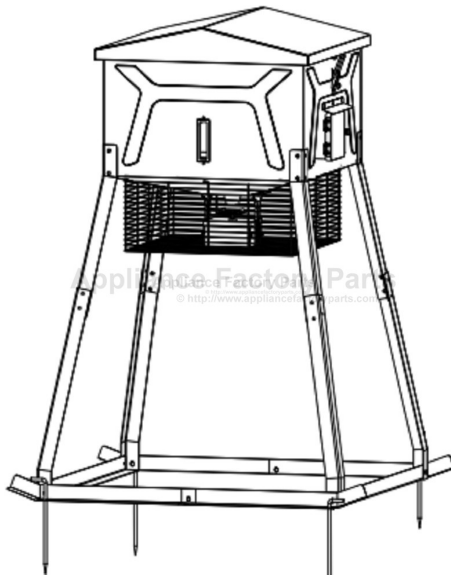

Rankam HU2220401-GW Owner's Manual

[Shop genuine replacement parts for Rankam
HU2220401-GW](#)



[Find Your Rankam Grill Parts - Select From 123 Models](#)

----- Manual continues below -----



GAME WINNER®

Assembly Instructions

300Lb Cube VP Feeder

Style # 143736 (HU2220401-GW)

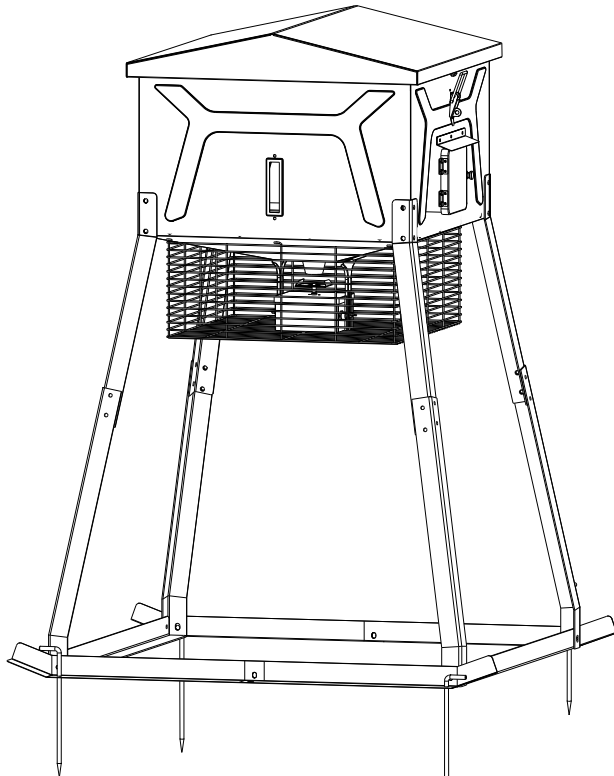

Please keep this instruction manual for future reference

**Customer Service: 1-888-837-1380, 8:00am to 5:00pm, Pacific Standard Time,
Monday thru Friday**

Email: customerservice@rankam.com

----- OR -----

Customer Service: 1-888-922-2336, 7:00am to 12:00am CST daily

Live Chat at: www.academy.com

Email: customerservice@academy.com

(Made in China)

Table of Contents	Page
--------------------------	-------------

Warnings -----	3-6
Tools required (not included) -----	7
Parts List -----	8-9
Hardware List -----	10
Component & Hardware List for Timer Kit Set -----	11-12
Product Diagram -----	13
Assembly Instructions -----	14-19
How to load your feeder -----	19
How to install the battery -----	20
How to operate the timer -----	20
Care and Maintenance -----	21
Assembly Instructions of 155060 Game Winner	
6V Solar Panel Charger (not included) -----	22-23
Warranty -----	24-25

NOTE: Before beginning assembly of product, make sure all parts are present. Compare parts with package content list and hardware contents. If any part is missing or damaged do not attempt to assemble the unit. Contact customer service for replacement parts.

Warnings

PAY ATTENTION to these statements when reading this manual and the information contained can save your life.

⚠ DANGER: Indicates an imminently hazardous situation which, if not avoided, will result in death or serious injury.

⚠ WARNING: Be alert to the possibility of serious bodily injury if the instructions are not followed. Be sure to read and carefully follow all of the messages.

⚠ CAUTION: Indicates a potentially hazardous situation which, if not avoided, may result in minor or moderate injury.

Your **GAME WINNER 300LB CUBE VP FEEDER** IS DESIGNED, ENGINEERED AND CONSTRUCTED IN A MANNER THAT MAKES IT A RUGGED PIECE OF HUNTING EQUIPMENT THAT WILL GIVE YOU YEARS OF SERVICE. THIS RUGGED CONSTRUCTION MAKES YOUR FEEDER PHYSICALLY HEAVY. AS SUCH, YOU SHOULD NEVER ATTEMPT TO ASSEMBLE THIS FEEDER ALONE. YOU MUST HAVE A MINIMUM OF TWO (2) ADULTS FOR THE SAFE ERECTION OF YOUR FEEDER. FAILURE TO FOLLOW THESE INSTRUCTIONS MAY RESULT IN SERIOUS INJURY OR DEATH!

THIS FEEDER MUST BE ERECTED ONLY ON A FIRM AND LEVEL GROUND. BEFORE FILLING THE HOPPER, **RECOMMEND INSTALLING FOUR (4) STAKES (PART #11)**. FAILURE TO FOLLOW THESE INSTRUCTIONS MAY RESULT IN SERIOUS INJURY OR DEATH!

REFER TO THE IMAGES IN THIS MANUAL FOR VISUALIZATION OF THE ASSEMBLY PROCESS IN ADDITION TO READING THE INSTRUCTIONS.

SOME PARTS MAY CONTAIN SHARP EDGES, SHARP POINTS, OR EDGES THAT CAN SCRATCH, POKE, OR PUNCTURE. WEAR APPROPRIATE CLOTHING AND SAFETY GLOVES DURING ASSEMBLY.

THIS UNIT IS HEAVY. DO NOT ASSEMBLE WITHOUT ANOTHER ADULT. FAILURE TO FOLLOW THESE INSTRUCTIONS MAY RESULT IN SERIOUS INJURY OR DEATH!

PRIOR TO ATTEMPTING TO USE THIS UNIT, TAKE A MOMENT TO BECOME FAMILIAR WITH THE ASSEMBLY, SETUP AND INSTALLATION. FAILURE TO FOLLOW THESE INSTRUCTIONS MAY RESULT IN SERIOUS INJURY OR DEATH!

Warnings

DO NOT USE THIS UNIT AROUND POWER GENERATING EQUIPMENT (TRANSFORMERS, GENERATORS, SUBSTATIONS, ETC) AND/OR TRANSMISSION EQUIPMENT (POWER LINES). FAILURE TO FOLLOW THESE INSTRUCTIONS MAY RESULT IN SERIOUS INJURY OR DEATH!

DO NOT LOAD FEEDER WITHOUT ANOTHER ADULT. FAILURE TO FOLLOW THESE INSTRUCTIONS MAY RESULT IN SERIOUS INJURY OR DEATH!

DO NOT LOAD FEEDER UNDER AND/OR DURING BAD WEATHER SUCH AS STORMS, SNOW, LIGHTNING OR THUNDERSTORM. FAILURE TO FOLLOW THESE INSTRUCTIONS MAY RESULTS IN SERIOUS INJURY OR DEATH!

DO NOT SIT OR STAND ON OR INSIDE THE HOPPER. FAILURE TO FOLLOW THESE INSTRUCTIONS MAY RESULT IN SERIOUS INJURY OR DEATH!

DO NOT LOAD OVER 300 POUNDS OF FEED. FAILURE TO FOLLOW THESE INSTRUCTIONS MAY RESULT IN SERIOUS DAMAGE TO THIS UNIT.

DO NOT LOAD FEEDER UNTIL IT IS COMPLETELY ASSEMBLED AND STANDING UP IN PLACE.

DO NOT STORE OR HANG ITEMS ON THE HOPPER. FAILURE TO FOLLOW THESE INSTRUCTIONS MAY RESULT IN SERIOUS DAMAGE TO THIS UNIT.

DO NOT DISASSEMBLE AND/OR REMOVE PARTS WITHOUT ANOTHER ADULT PRESENT. FAILURE TO FOLLOW THESE INSTRUCTIONS MAY RESULT IN SERIOUS INJURY OR DEATH!

DO NOT ASSEMBLE, DISASSEMBLE, AND/OR REMOVE PARTS FROM THE FEEDER UNDER AND/OR DURING BAD WEATHER SUCH AS STORMS, SNOW, LIGHTNING, OR THUNDERSTORMS. FAILURE TO FOLLOW THESE INSTRUCTIONS MAY RESULT IN SERIOUS INJURY OR DEATH!

THE 6V RECHARGEABLE BATTERY (NOT INCLUDED) SHOULD HAVE A COMPLETE CHARGE PRIOR TO THE FIRST TIME OF OPERATION. REFER TO USER INSTRUCTION OF THE BATTERY.

THE PROPER SPACING BETWEEN THE SPIN PLATE AND THE FUNNEL IS 3/8 INCH. THIS IS VERY IMPORTANT FOR SERVICE FREE OPERATION.

Warnings

TO TEST YOUR FEEDER FOLLOW THE INSTRUCTIONS IN THE TIMER MANUAL. DO NOT TEST FEEDER WHEN IT CONTAINS FEED. TEST FEEDER WHEN EMPTY ONLY! TESTING THE FEEDER WHILE IT CONTAINS FEED WILL CAUSE FEED TO BE DISCHARGED AT A HIGH VELOCITY AND COULD RESULT IN BODY INJURY. FAILURE TO FOLLOW THESE INSTRUCTIONS MAY RESULT IN SERIOUS INJURY OR DEATH!

THOROUGHLY INSPECT THE FEEDER PRIOR TO EACH USE FOR SIGNS OF WEAR, ROT, CORROSION, CRACKS, DETERIORATION AND/OR ANY OTHER TYPE OF DEFECT. DO NOT USE THIS FEEDER IF IT SHOWS EVIDENCE OF WEAR, ROT, CORROSION, CRACKS, DETERIORATION AND/OR ANY OTHER TYPE OF DEFECT. FAILURE TO FOLLOW THESE INSTRUCTIONS MAY RESULT IN SERIOUS INJURY OR DEATH. DO NOT REMOVE, MODIFY AND/OR OMIT ANY PART OR OTHERWISE MECHANICALLY MODIFY THIS UNIT OR ITS ASSEMBLY IN ANY MANNER. MODIFICATION, OMISSION AND/OR PART SUBSTITUTION MAY RESULT IN SERIOUS INJURY OR DEATH!

OPERATION IS SUBJECT TO THE FOLLOWING TWO CONDITIONS:

- THIS DEVICE MAY NOT CAUSE HARMFUL INTERFERENCE.
- THE DEVICE MUST ACCEPT ANY INTERFERENCE RECEIVED, INCLUDING INTERFERENCE THAT MAY CAUSE UNDESIRE OPERATION.

BEFORE STANDING UP THE FEEDER, YOU MUST...

CHECK ALL HARDWARE TO BE SURE IT IS IN PLACE AND TIGHT.

CHECK ALL BOLTS AND NUTS TO BE SURE THEY ARE FIRM AND TIGHT.



DO NOT THROW AWAY THE PACKAGING MATERIAL AT THIS TIME.







! IMPORTANT !

THE MANUFACTURER OF THE 300LB CUBE VP DEER FEEDER IS NOT RESPONSIBLE FOR ANY INACCURATE INFORMATION YOU HAVE RECEIVED REGARDING STATE FEEDING REGULATIONS. PLEASE ALWAYS KEEP YOUR INFORMATION UP-TO-DATE AND RELIABLE. MANY STATE LAWS CHANGE AND ARE AMENDED WITHOUT NOTICE. ALWAYS DOUBLE CHECK YOUR STATE AND SPECIFIC COUNTY FEEDING LAWS REGARDING THE USE OF FEEDERS.

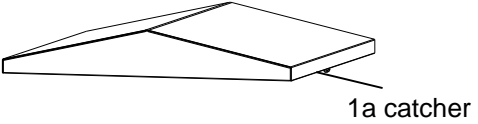
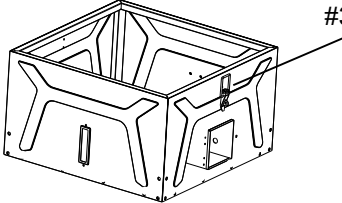

Tools Required (not included)

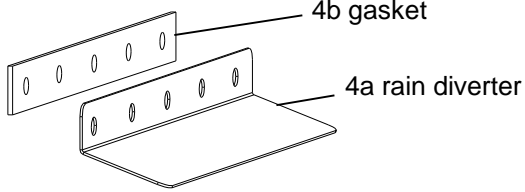
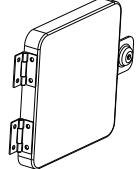
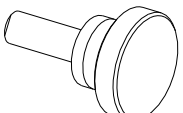
1	Philips & Flathead Screwdrivers	
2	Pliers	
3	Wrench	



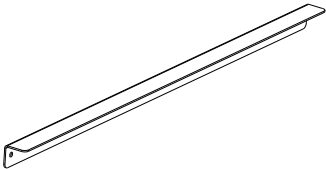
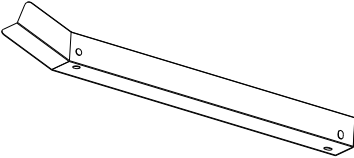
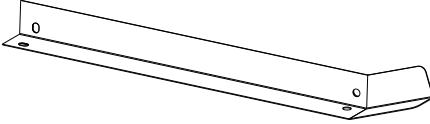

Parts List

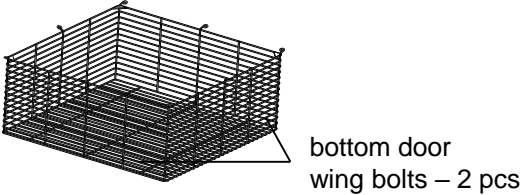
1	<p>Lid</p> <p>1a –catcher – 2 pcs (pre-attached on lid)</p>	 <p>1a catcher</p>	1 pc
2	<p>Hopper</p>	 <p>#3 latch</p>	1 pc
3	<p>Latch</p> <p>(pre-attached on hopper)</p>		2 pcs
4	<p>4a - Rain Diverter</p> <p>4b - Gasket</p>	 <p>4b gasket</p> <p>4a rain diverter</p>	1 set
5	<p>Door</p> <p>(pre-attached on hopper)</p>		1 pc
6	<p>Door Knob</p> <p>(pre-attached on door)</p>		1 pc
7	<p>Upper Leg</p>		4 pcs
8	<p>Lower Leg</p>		4 pcs

Parts List

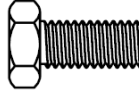

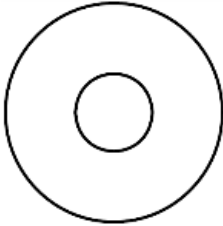
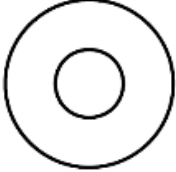
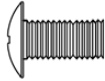
9	Leg Blade		2 pcs
10A	Leg Skid Blade - A		2 pcs
10B	Leg Skid Blade - B		2 pcs
11	Stake		4 pcs
12	Varmint Guard		1 pc

Hardware List

A	Hex. Bolt (M8x15)		44 pcs
B	Hex. Bolt (M6x20)		13 pcs
C	Locking Nut (M8)		44 pcs
D	Flat Washer (dia. 8mm)		88pcs
E	Flat Washer (dia. 6mm)		8 pcs
SP1	Bolt M5x12		2 pcs
SP2	Nut M5		2 pcs
SP3	Bolt M6x20 (pre-attached on hopper)		2 pcs



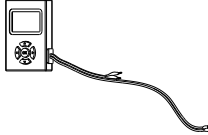

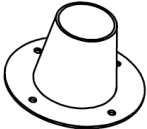
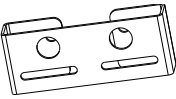
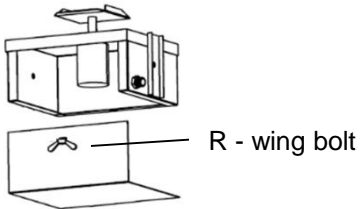
Parts List - Timer Kit Set – Component

!! Components are packed INSIDE the Timer Kit Set package!!

13	<p>Wire Conduit</p> <p>i.) Long conduit – silver</p> <p>ii.) Short conduit – black</p>		2 pcs
14	Digital Timer		1 pc
15	Mounting Bracket		2 pcs
16	Funnel		1 pc
17	Solar Panel Fixture Bracket		1 pc
18	<p>Metal Timer Kit Housing</p> <p>R – wing bolt</p>		1 pc

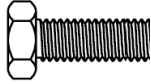
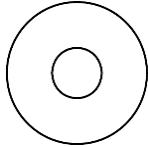
Parts List - Timer Kit Set – Hardware

!! Hardware are packed INSIDE the Timer Kit Set package!!

K	Hex. Bolt (M6x20)		10 pcs
L	Flat Washer (dia. 6mm)		2 pcs
M	Butterfly Nut (M6)		2 pcs
N	Flange Nut (M6)		2 pcs
R	Wing Bolt (M6)		1 pc

Product Diagram

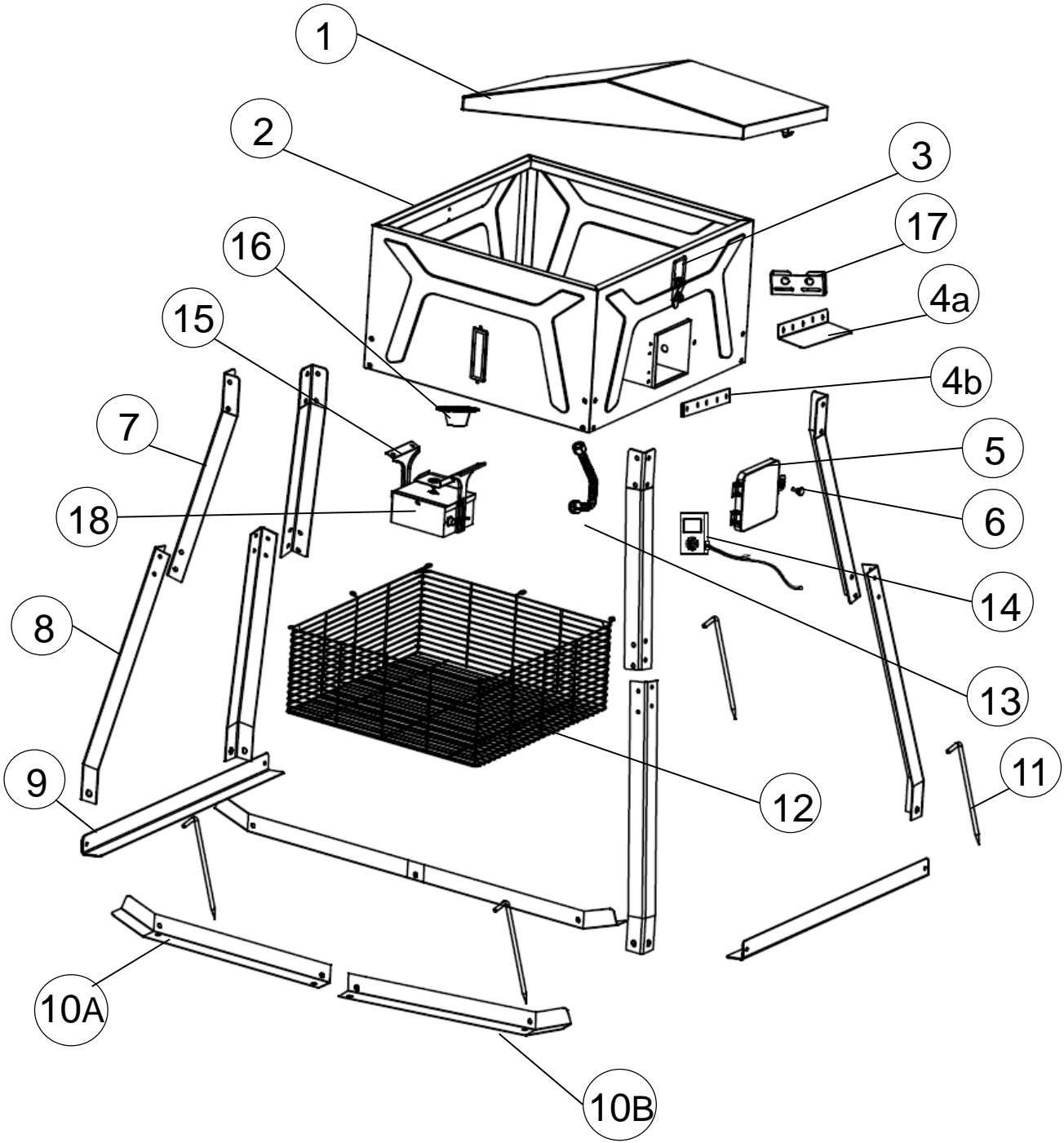

Assembly Instructions

Step 1:

Attach Mounting bracket (#15) to the Metal Timer kit Housing (#18) using bolts (K, M6x20), flange nut (N, M6), washer (L, 6mm) and butterfly nuts (M, M6). Wing Bolt (R) to secure door. (All hardware is packed inside the Timer Kit unit).

Hardware :

#K - 2 pcs #L - 2 pcs
#M - 2 pcs #N - 2 pcs
#R - 1 pc

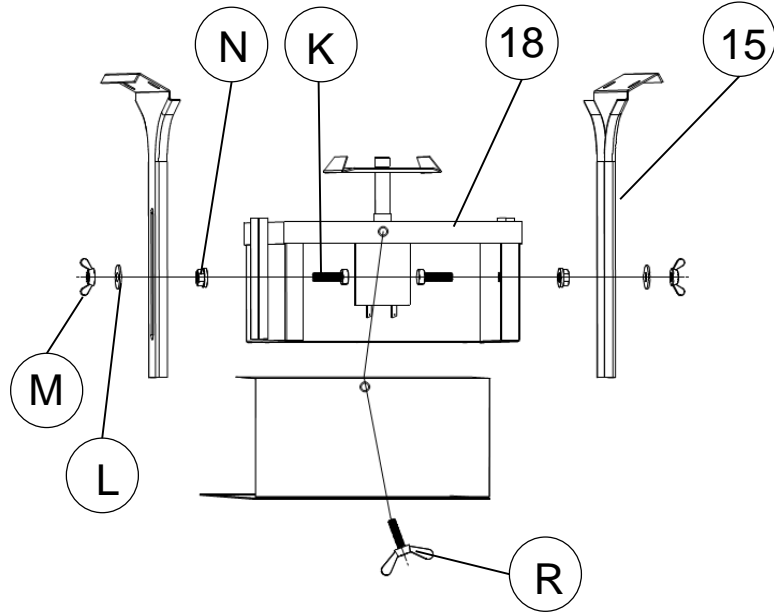

Step2:

Attach Funnel (#16) and Timer Kit Set to the bottom of hopper using bolts (K, M6x20), packed inside the Timer Kit unit.

Hardware :

#K – 8 pcs

Attention : the conduit connector on side of timer box and the conduit connector at bottom of hopper should be on the same side.

See Pg. 20 for proper spacing of spinner plate to funnel (3/8")

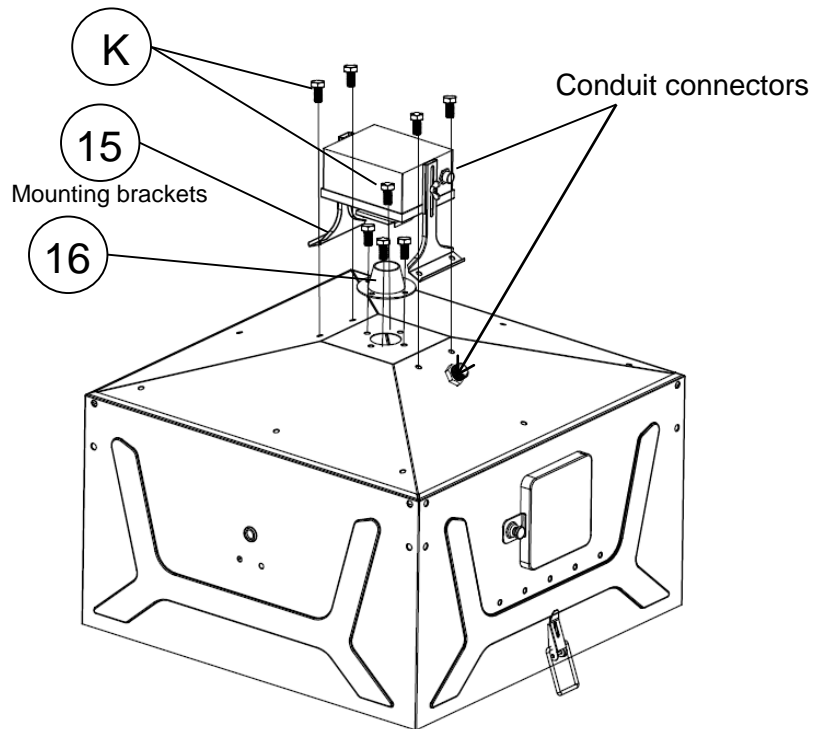

Assembly Instructions

Step 3:

Attach Wire Conduit (#13) inside hopper and at bottom of hopper per diagram.

Long conduit – connects to compartment in hopper and bottom of hopper

Short conduit – connects to timer housing and bottom of hopper

Blue and White wires from Digital Unit (#14) pass through conduits and connect to motor in Metal Timer Kit Housing

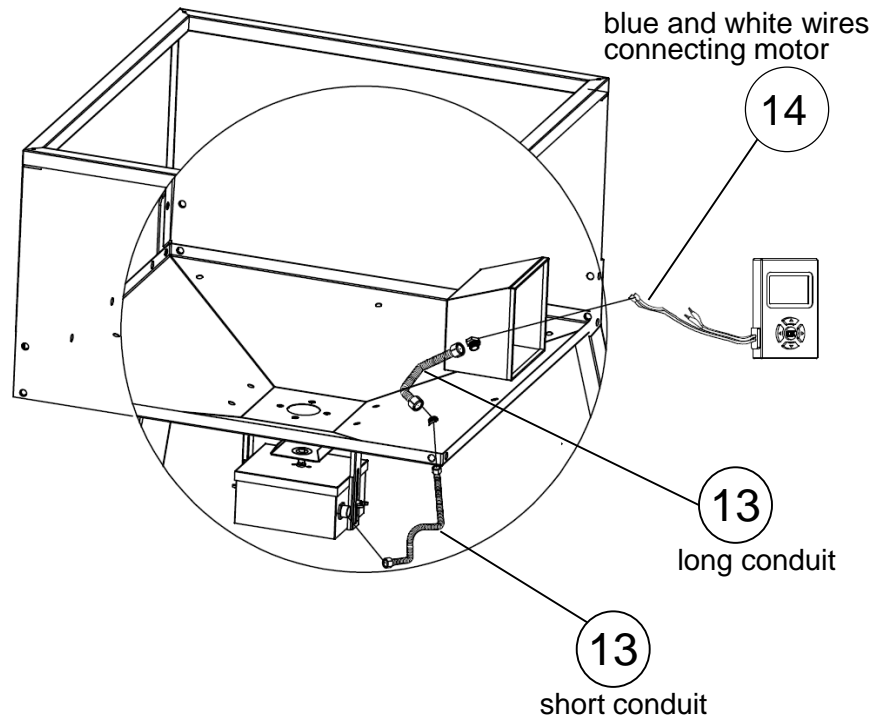

Step 4:

Attach the Varmint Guard (#12) to the bottom of hopper using bolts (B, M6x20) and flat washers (E, 6mm).

Hardware :

#B - 8 pcs

#E - 8 pcs

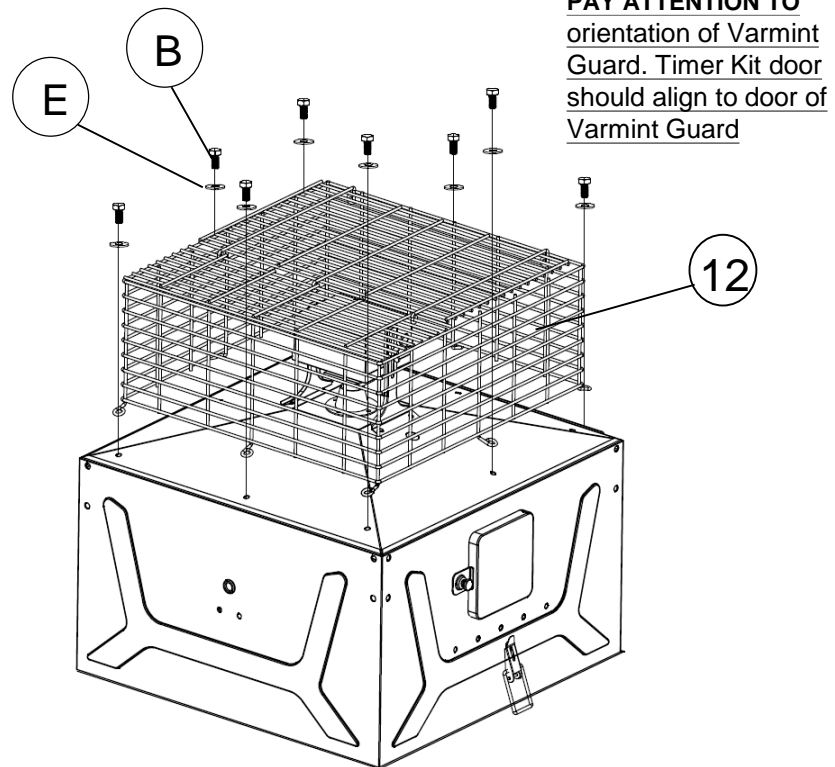

Assembly Instructions

Step 5:

Attach Upper Legs (#7) to hopper using bolts (A, M8x15), flat washers (D, 8 mm) and locking nuts (C, M8). **DO NOT TIGHTEN** bolts and nuts in this step.

Hardware :

#A - 16 pcs

#C - 16 pcs

#D - 32 pcs

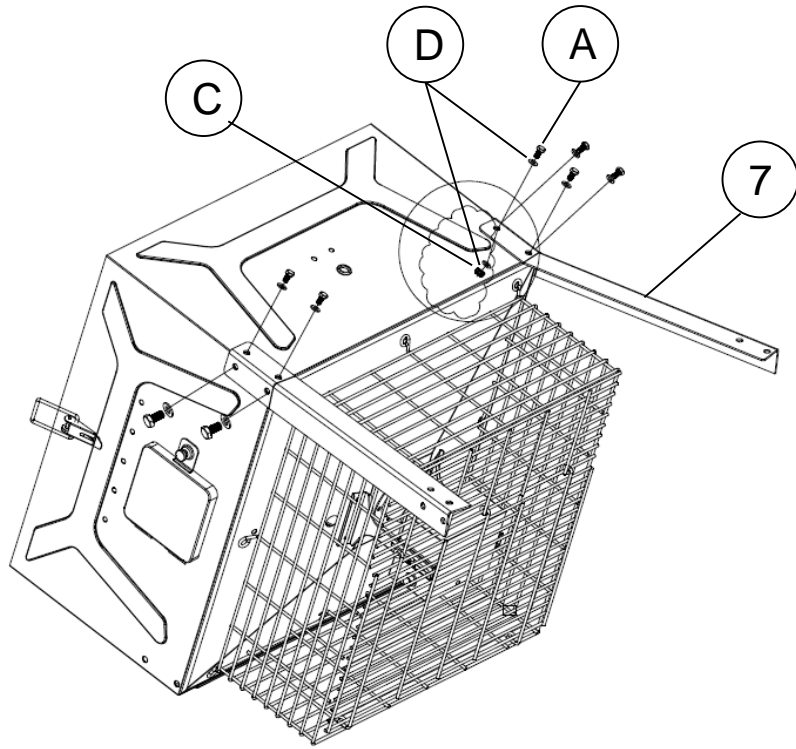

Step 6:

Attach Lower Legs (#8) to Upper Legs (#7) using bolts (A, M8x15), flat washers (D, 8 mm) and locking nuts (C, M8). **DO NOT TIGHTEN** bolts and nuts in this step.

Hardware :

#A - 16 pcs

#C - 16 pcs

#D - 32 pcs

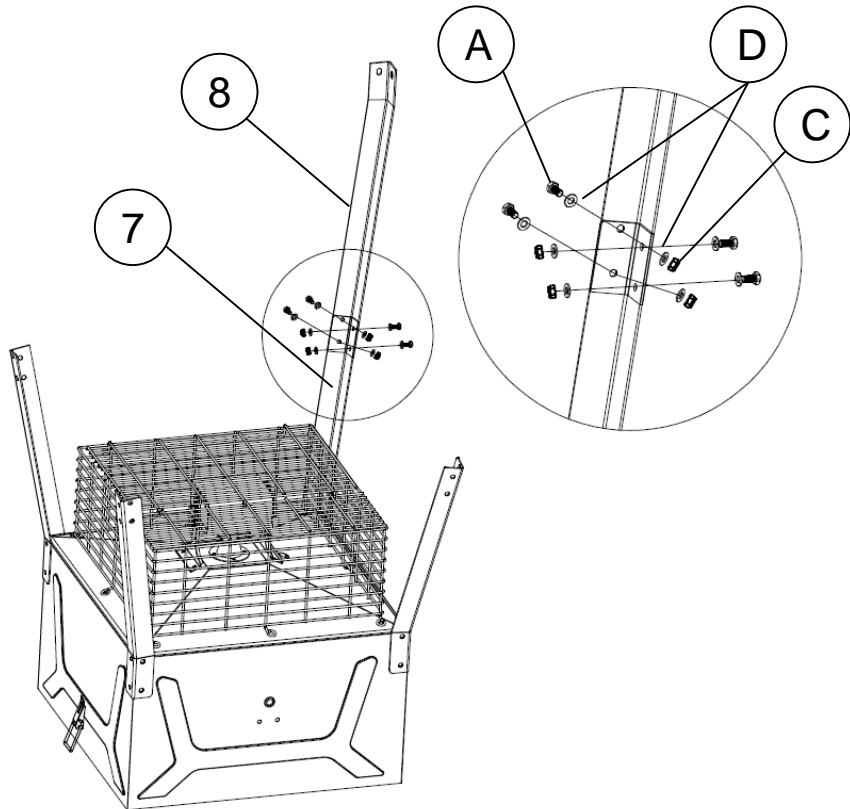

Assembly Instructions

Step 7:

Attach Leg Blades (#9) to legs using bolts (A, M8x15), flat washers (D, 8mm) and locking nuts (C, M8). **DO NOT TIGHTEN** bolts and nuts in this step.

Hardware :

#A - 4 pcs

#C - 4 pcs

#D - 8 pcs

PAY ATTENTION TO
orientation of hopper
when attaching leg
blades

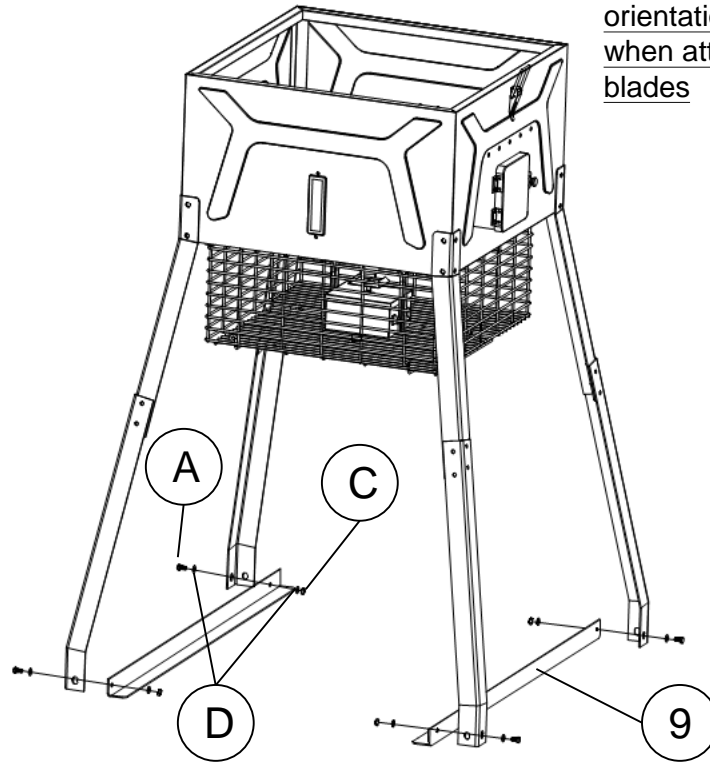

Step 8:

Assemble Leg Skid Blades (#10A & #10B) using bolts (A, M8x15), flat washers (D, 8mm) and locking nuts (C, M8). **DO NOT TIGHTEN** bolts and nuts in this step.

Hardware :

#A - 4 pcs

#C - 4 pcs

#D - 8 pcs

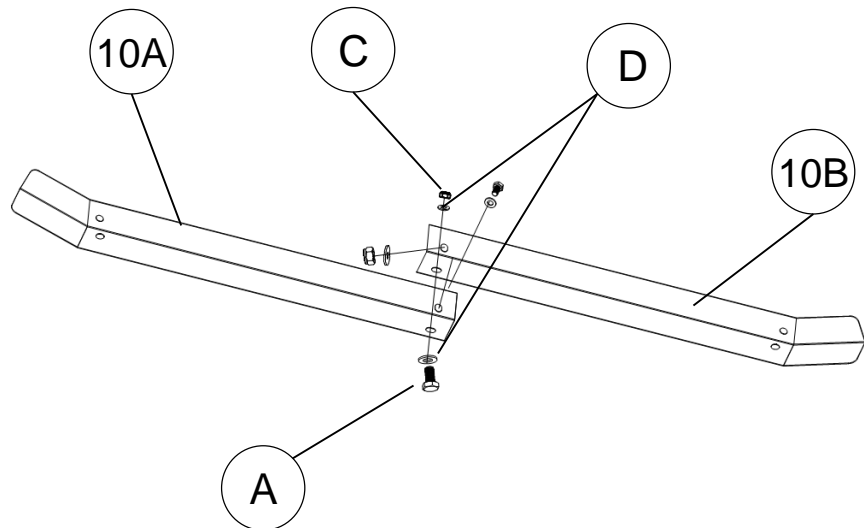

Assembly Instructions

Step 9:

Attach Leg Skid Blade in previous step to legs using bolts (A, M8x15), flat washers (D, 8mm) and locking nuts (C, M8)

TIGHTEN ALL bolts and nuts now including the hardware in Step #5,6,7,8

Hardware :

#A - 4 pcs

#C - 4 pcs

#D - 8 pcs

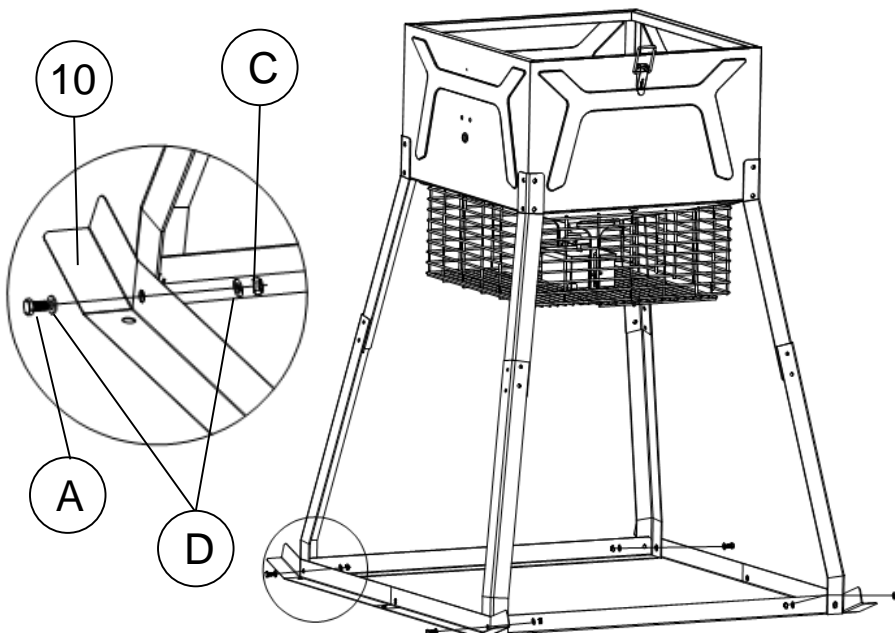

Step 10:

Attach Rain Diverter (#4a) and Gasket (#4b) to the hopper (above door) using bolts (B, M6x20)

Hardware :

#B - 5 pcs

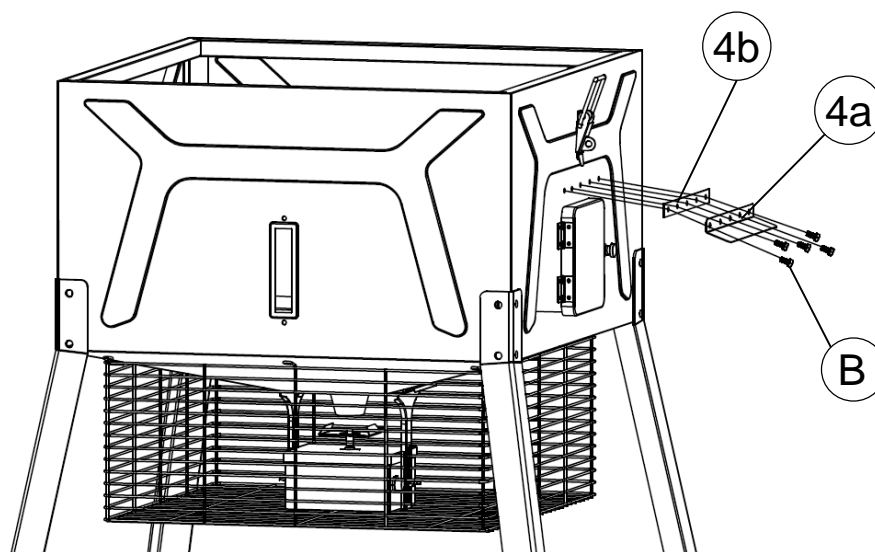

Assembly Instructions

Step 11:

Attach Lid (#1) to the hopper following the diagram. Tighten all bolts and nuts and affix the feeder to the ground with 4 ground stakes (#11) before use.

Your feeder assembly is completed.

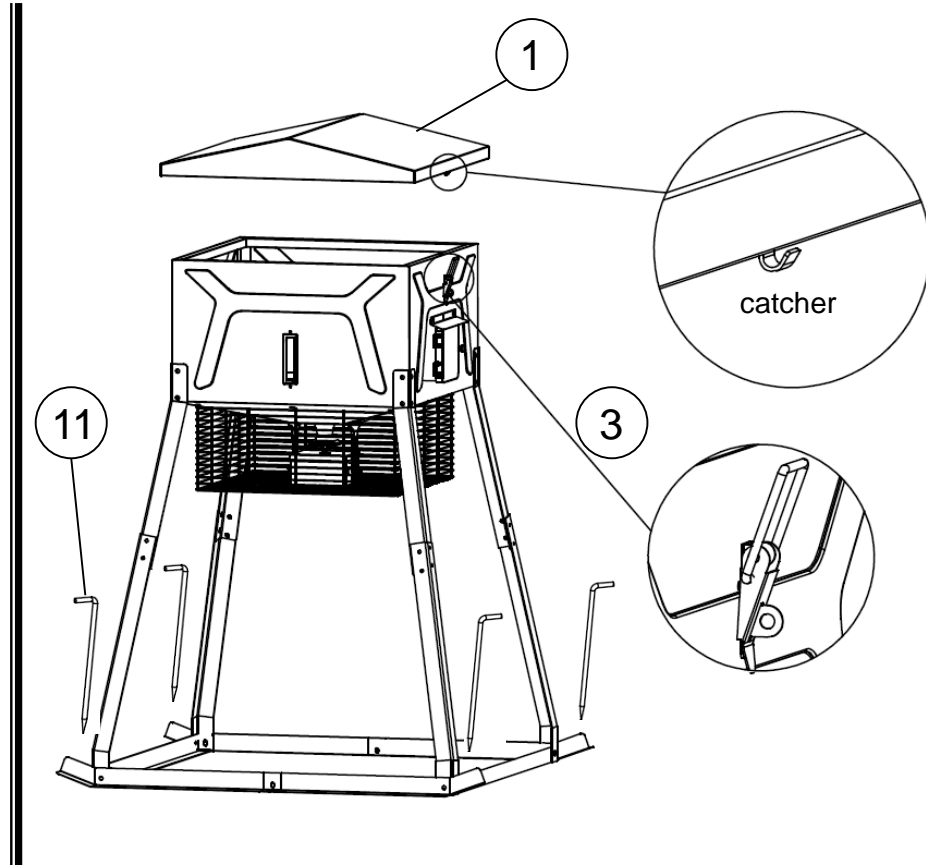

HOW TO LOAD YOUR FEEDER

OPEN THE LID AND POUR FEED INTO THE HOPPER. AFTER FILLING, CLOSE THE LID.

TIPS & POINTERS:

(Q) What kind of feed should I use?

(A) Whole kernel corn is recommended. Whole kernel corn mixed with soybeans or pellets is also effective for attracting deer. NOTE: When not mixed with corn, some types of pellets can take on moisture and clog the feeder.

HOW TO INSTALL BATTERY



REMOVE TIMER KIT COVER AND INSTALL A 6V RECHARGEABLE BATTERY (NOT INCLUDED) BY ATTACHING RED ALLIGATOR CLIP TO THE POSITIVE (+) AND BLACK ALLIGATOR CLIP TO THE NEGATIVE (-) TERMINAL.

HOW TO OPERATE THE TIMER

READ THE OPERATION MANUAL INCLUDED IN THE TIMER KIT UNIT.

THE PROPER SPACING BETWEEN THE SPIN PLATE AND THE FUNNEL IS 3/8 INCH (0.953 cm). THIS IS VERY IMPORTANT FOR SERVICE- FREE OPERATION.

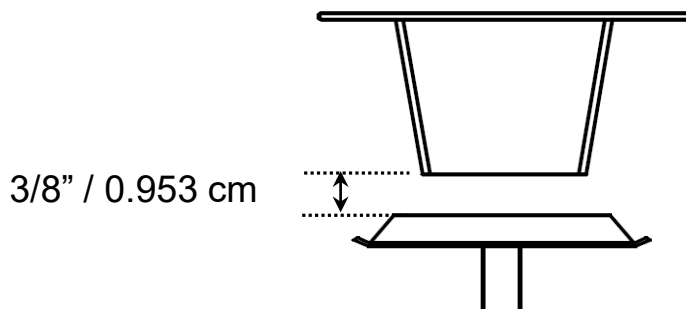

Care and Maintenance

- INSPECT FEEDER FOR ANY LOOSE PARTS OR HARWARE REGULARLY
 - CHECK IF FEEDER IS TAKING WATER ON RAINY DAYS. SEAL GAP WITH SILICONE SEALANT IF NECESSARY
 - IF RUST APPEARS ON THE EXTERIOR SURFACE OF FEEDER, CLEAN AND BUFF THE AFFECTED AREA WITH STEEL WOOL OR FINE GRIT EMERY CLOTH. TOUCH-UP WITH A GOOD QUALITY PAINT
 - STORE FEEDER INDOORS WHEN NOT IN USE
 - CLEAN FEEDER HOPPER REGULARLY TO AVOID CLOGGING AND DAMAGE TO THE CONTROL UNIT
-



ATTENTION



- **IF USING THE GAME WINNER TIMER AS A REPLACEMENT TIMER, IT WILL WORK WITH EITHER 6V OR 12V MOTORS. *IF USING A 6V MOTOR, USE A 6V BATTERY. IF USING 12V MOTOR, USE A 12V BATTERY.***

******* GAME WINNER MOTORS ARE 6V. *******

Assembly Instructions of 155060 Game Winner 6V Solar Panel Charger (not included)

Step 1:

Attach Game Winner Solar Panel Charger directly to the hopper panel using bolts (SP3, M6x20).

Note: It is recommended to install Solar Panel before loading or when it is empty.

Hardware:
#SP3 - 2 pcs

155060 Game Winner 6V Solar Panel Charger Assembly (not included)

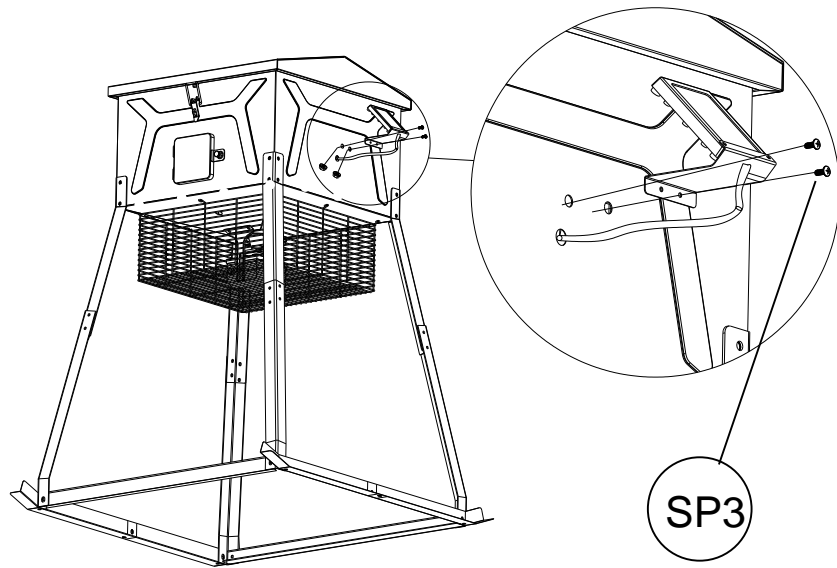

For use of NON-Game Winner Solar Panel Charger (not included), follow below instructions

Attach Solar Panel Fixture Bracket (#17) on side of hopper using bolts (SP3, M6x20).

Hardware:
#SP3 - 2 pcs

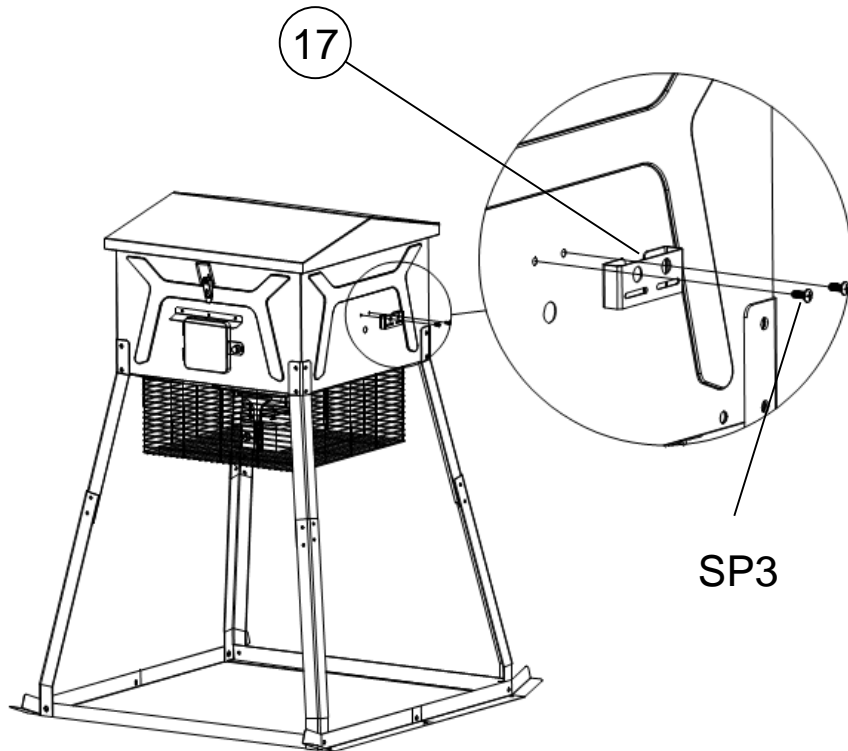

Assembly Instructions of 155060 Game Winner 6V Solar Panel Charger (not included)

Attach NON-Game Winner Solar Panel Charger to Solar Panel Fixture Bracket using bolts (SP1, M5x12) and nuts (SP2, M5).

Hardware:
#SP1 - 2 pcs
#SP2 - 2 pcs

Non-Game Winner 6V Solar
Panel Charger Assembly (not included)

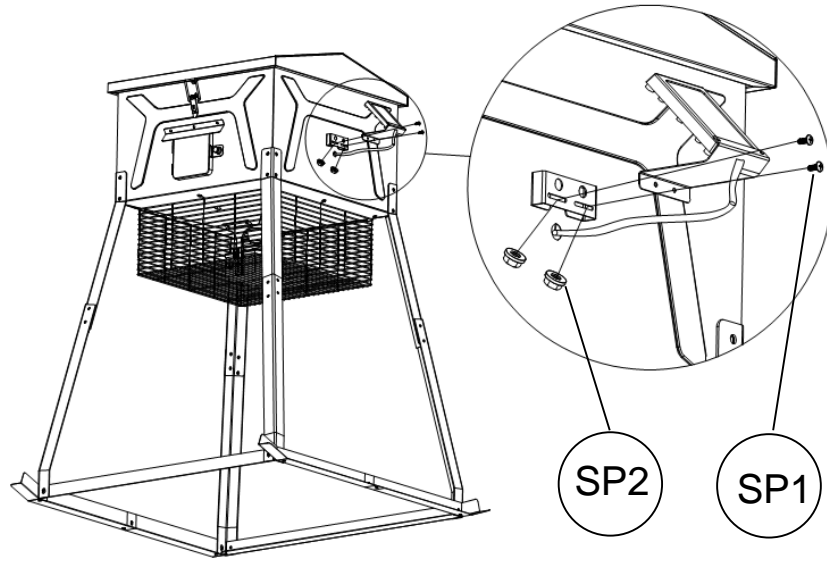

Step 2:

With a knife, make an incision to each of the rubber gaskets so that the wire conduit can be inserted into hopper and through the hole into the compartment.

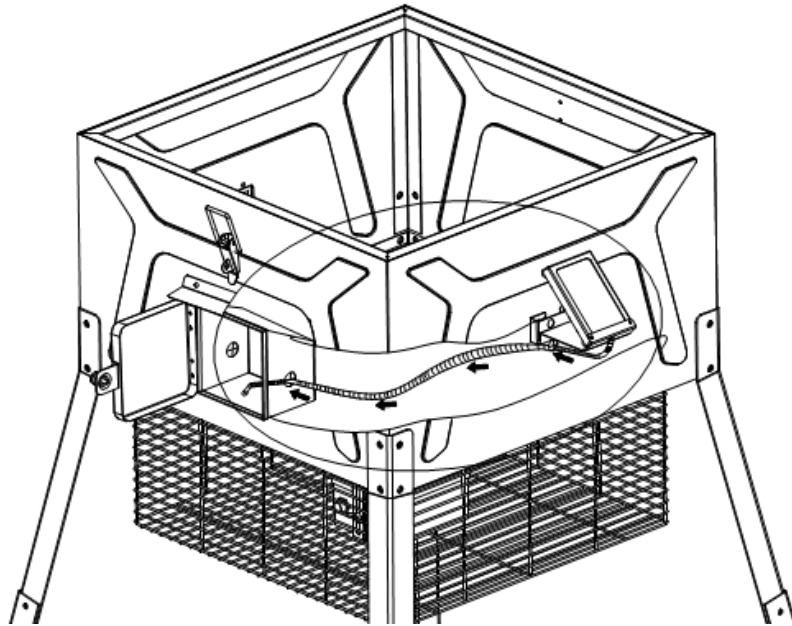

Warranty Information

1. Manufacturer warrants this Product to be free from defects in workmanship and materials for a period of 90 days from the date of purchase, PROVIDED claims are submitted, in writing, with proof of purchase.
2. If any part of this item fails because of a manufacturing defect within the Limited Warranty Period, Manufacturer offers to replace such part(s) provide that such parts have not been improperly repaired, altered, or tampered with or subject to misuse, abuse or exposed to corrosive conditions. This Limited Warranty is, however, subject to certain limitations, exclusions, time limits and exceptions (Hereinafter "Conditions") as listed below. Read these Conditions carefully.
3. This Limited Warranty shall be limited to the replacement or repair of any part(s) which Manufacturer determines, after reasonable examination, to have been defective at the time of manufacturing and manufacturer's obligation(s) shall be limited to replacement, if any, of defective part(s) which shall be shipped at Original Purchaser's expense to Original Purchaser's designated shipping address.
4. This Limited Warranty is given to and covers the **ORIGINAL PURCHASER ONLY** and such coverage terminates 90 days from the date of purchase.
5. **DAMAGE LIMITATION WARNING:** IN NO EVENT SHALL MANUFACTURER BE LIABLE FOR ANY INCIDENTAL OR CONSEQUENTIAL DAMAGES, INCLUDING (BUT NOT LIMITED TO) LOSS OF USE OF THE PRODUCT, LOSS OF TIME, INCONVENIENCE, EXPENSES FOR TRAVEL, TRANSPORTATION, LODGING EXPENSES, LOSS OF FOOD, LOSS BY DAMAGE TO PERSONAL PROPERTY OR LOSS OF INCOME, PROFITS OR REVENUE.
6. **MANUFACTURER'S OBLIGATION:** Manufacturer's liability shall be limited to the delivery of a good, merchantable Product and, if necessary, the repair or replacement, at manufacturer's option, of any defective part or unit.
7. **TRANSFER LIMITATIONS:** This Limited Warranty is not assignable or transferable. It covers only the original purchaser.
8. **RESERVED RIGHT TO CHANGE:** Manufacturer reserves the right to make changes or improvements to products it produces in the future without imposing on itself any obligations to install the same improvements in the products it has previously manufactured.
9. This Limited Warranty gives the Original Purchaser specific legal rights but there may be other rights which vary by jurisdiction.
10. **This warranty does not cover the following items:**
 - Chips or scratches on porcelain or painted surfaces
 - Rust or corrosion is not deemed a manufacturing or materials defect
 - Discoloration or loss of paint due to handling during assembly, heat or cleaning products. Paint may require touch up.
 - Stainless steel discoloration or corrosion
 - Consumables such as batteries
 - Damages caused by wild game

IF CUSTOMER SERVICE IS NECESSARY:

The original purchaser is responsible for shipping and handling charges of the returned item(s) and replacement parts, if any.

All parts to be replaced will need to be shipped before replacement items will be sent.

Follow the customer service representative's instructions exactly. If a return is necessary, it must be packed carefully and shipped prepaid.

Should you encounter any problems
obtaining replacement parts,
CALL US FIRST.

Do not return product to the store.
WE CAN HELP.

Rankam (China) Manufacturing Co. Ltd.
18/F., New Lee Wah Centre, 88 Tokwawan Road,
Kowloon, Hong Kong

Please contact Rankam Customer Service at
customerservice@rankam.com
or at 1-888-837-1380, Mon to Fri, 8:00 a.m. – 5:00 p.m. Pacific Standard Time.