

This Owner's Manual is provided and hosted by [Appliance Factory Parts](#).

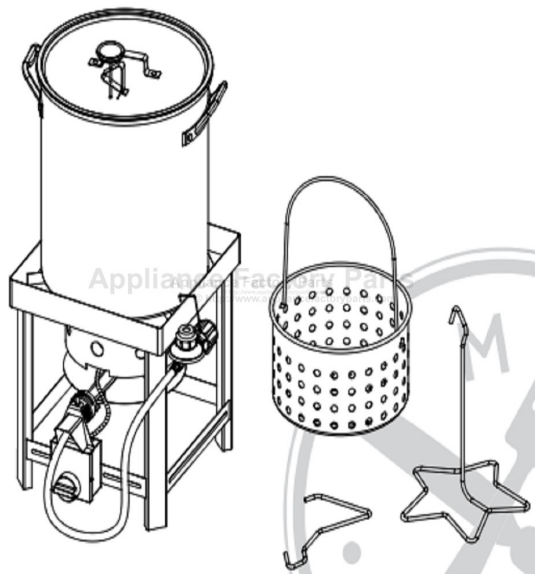

Rankam TF2115708-MC-00 Owner's Manual

[Shop genuine replacement parts for Rankam
TF2115708-MC-00](#)



[Find Your Rankam Grill Parts - Select From 123 Models](#)

----- Manual continues below -----

MASTER
Chef[™]

Outdoor Propane Turkey Fryer

Product no. 085-3230-2 (TF2115708-MC-00)

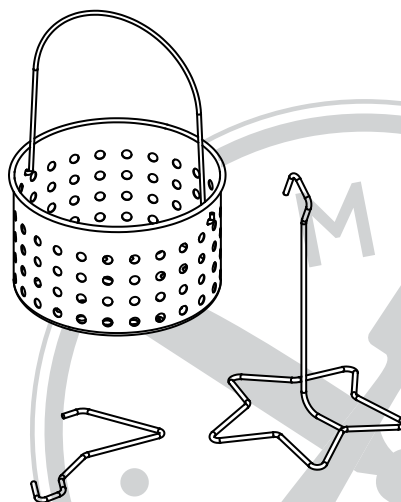
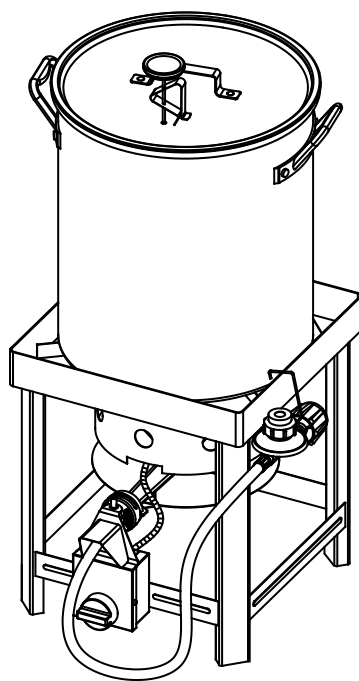

INSTRUCTION MANUAL

Toll-free: 1-855-803-9313

Read this manual thoroughly before using and save it for future reference.

Product no. 085-3230-2 (TF2115708-MC-00) |
Contact us: 1-855-803-9313

Warnings	2
Product Diagram	4
Component List	5
Hardware List	5
Assembly Instructions	6
Troubleshooting	10
Limited Warranty	11

- To installer or person assembling this appliance: Leave this manual with this appliance for future reference.
- This instruction manual contains important information necessary for the proper assembly and safe use of the appliance.
- Read and follow all warnings and instructions before assembling and using the appliance.
- Follow all warnings and instructions when using the appliance.
- Keep this manual for further reference.

SAFETY SYMBOLS:

The symbols and boxes shown below explain what each heading means.
Read and follow all of the messages found throughout the manual.



DANGER: Indicates an imminent hazardous situation which, if not avoided, will result in death or serious injury.



WARNING: Indicates a potentially hazardous situation which, if not avoided, could result in death or serious injury.



CAUTION: Indicates a potentially hazardous situation which, if not avoided, may result in minor or moderate injury.

**DANGER:**

If you smell gas:

1. Shut off gas to the appliance.
2. Extinguish any open flame.
3. If odour continues, keep away from the appliance and immediately call your gas supplier or fire department.

Failure to follow these instructions could result in fire or explosion which could cause property damage, personal injury or death.

**DANGER:**

1. Never operate this appliance unattended.
2. Never operate this appliance within 10' (3.0 m) of any structure, combustible material or other gas cylinder.
3. Never operate this appliance within 25' (7.5 m) of any flammable liquid.
4. Do not fill cooking vessel beyond maximum fill-line.
5. Never allow oil or grease to get hotter than 400°F or 200°C. If the temperature exceeds 400°F (200°C) or if oil begins to smoke, immediately turn the burner or gas supply OFF.
6. Heated liquids remain at scalding temperatures long after the cooking process.
Never touch cooking appliance until liquids have cooled to 115°F (45°C) or less.
7. If a fire should occur, keep away from the appliance and immediately call your fire department.
Do not attempt to extinguish an oil or grease fire with water.

Failure to follow these instructions could result in fire or explosion which could cause property damage, personal injury or death.

**WARNING:**

This appliance is not intended for commercial use.

**WARNING:**

1. Never leave the appliance unattended.
Keep children and pets away from the appliance at all times.
2. The use of alcohol, prescription or non-prescription drugs may impair the consumer's ability to properly assemble or safely operate the appliance.
3. This appliance must not be used on or under any apartment or condominium balcony or deck.
4. This appliance is for OUTDOOR USE ONLY.
DO NOT use in a building, garage or any other enclosed area.
5. This appliance is not intended to be installed in or on a boat.
This appliance is not intended to be installed in or on recreational vehicles.
6. This appliance is not intended for and should never be used as a heater.
7. When cooking, the fryer/boiler must be on a level, stable noncombustible surface in an area clear of combustible material. An asphalt surface (blacktop) is not acceptable for this purpose.

Product no. 085-3230-2 (TF2115708-MC-00) |
Contact us: 1-855-803-9313

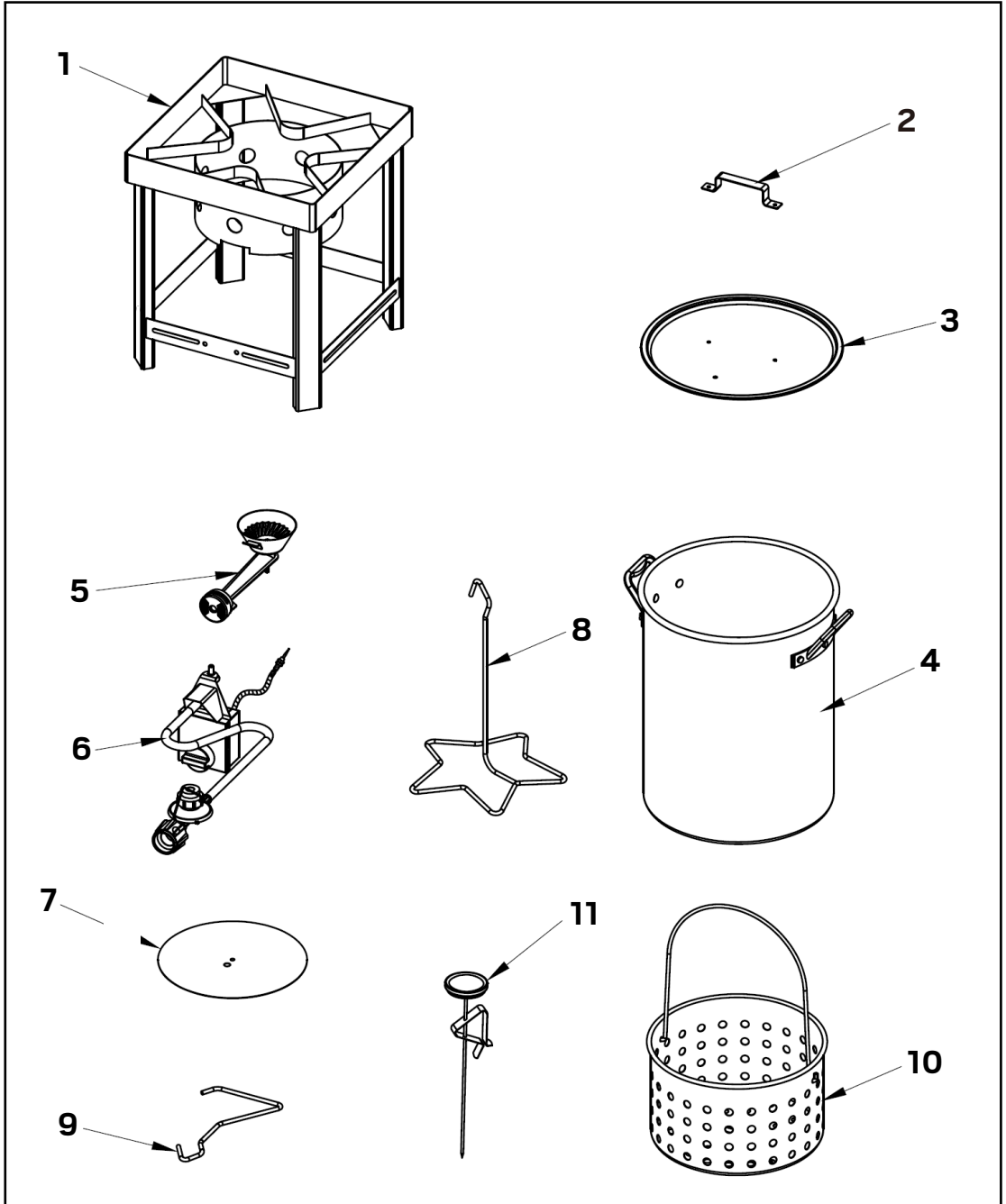

Key No.	Description	Qty.
1	Steel stand	1
2	Pot lid handle	1
3	Pot lid	1
4	36 qt (34 L) aluminum pot	1
5	Burner	1
6	Timer control box	1
7	Heat shield	1
8	T-star stand	1
9	Lifter	1
10	Strainer basket	1
11	15" (38.1 cm) Thermometer	1

Part No.	Description	Diagram	Qty.
A	M6 x 12 Bolt		2

Tools required (not included):
 Cross-head screwdriver / Adjustable wrench

Step 1

Attach the burner (5) to automatic shut off valve in the timer control box (6) by turning the burner clockwise. Do not fully tighten the burner to the valve; tighten until 3 threads remain visible on the valve.

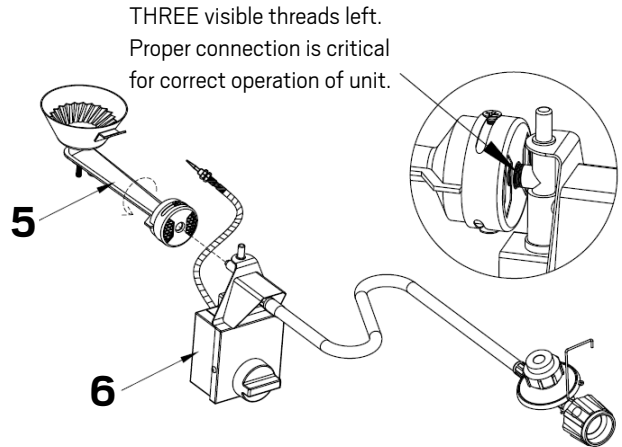

Step 2

Attach thermocouple (D) to thermocouple bracket (E) which has been fixed to the burner. Attach thermocouple (D) as per right drawing and tighten the nut (Y).

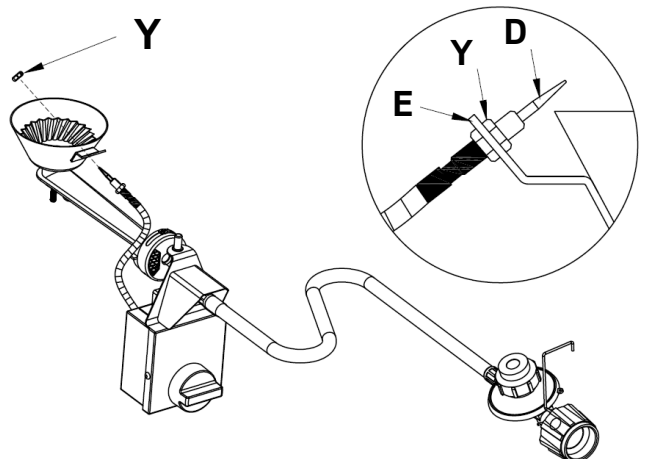

Step 3

Unscrew the pre-assembled nut from the threaded pin of the burner (5). Insert the burner through the bottom of the stand (1), between the wind shield (F) (side with rectangle lip) and burner support bar (G).

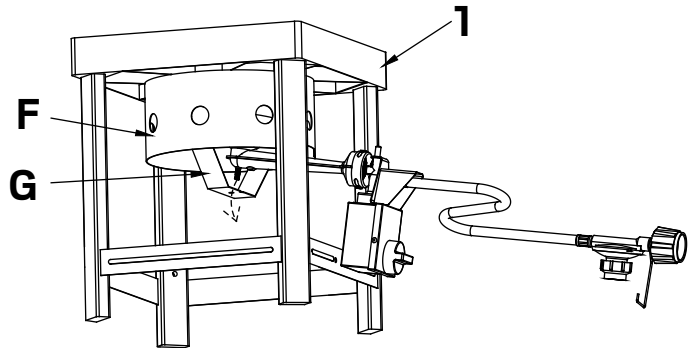

Step 4

Align timer control box (6) to the timer box support bar (H) and secure it with 2 pieces M6x12 screws by going through the support bar (H) and then into the timer control box (6). Align burner (5) base to burner support bar (G). Align holes on heat shield (7) with threaded pin and alignment pin of the burner (5) through hole in burner support bar (G), then through small hole of heat shield (7). The alignment pin on bottom of burner (5) must be inserted through the large hole of the heat shield (7). Tighten hex nut onto bolt of the burner (5).

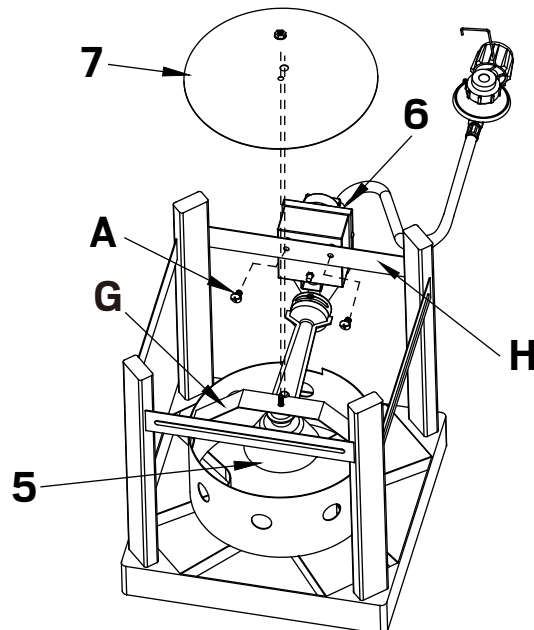

Step 5

When transporting or storing LP cooker without tank attached, hook regulator onto burner or cooker stand to prevent damage to regulator.

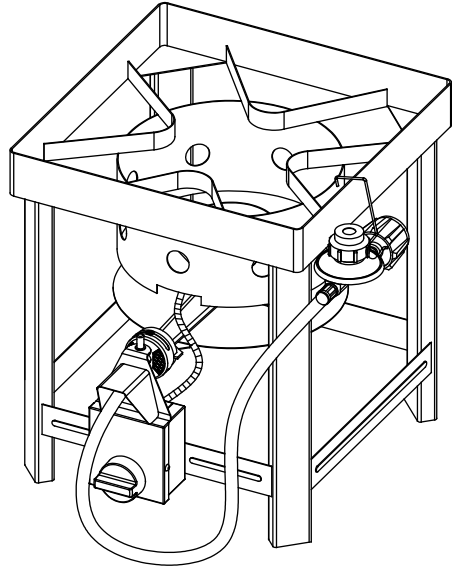

Step 6

Finally, unscrew the two screws from the lid handle by loosening the nuts. Align the lid handle on the lid and secure by reattaching the nuts to the screws.

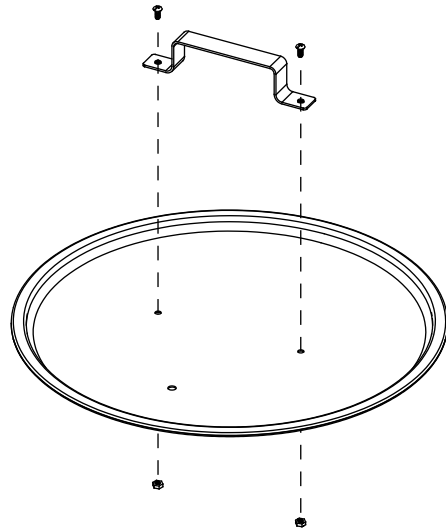

Problem	Possible Cause	Corrective Action
The burner does not light up.	The connection between the regulator and LP tank are not in good condition.	Check and make sure the regulator coupling nut is tightened to the LP tank valve.
	The LP tank valve and regulator control valve are not open.	The regulator control valve and LP tank valve is open during normal operation. The regulator control valve is opened in clockwise direction and the LP tank valve is opened in counter-clockwise direction.
	The LP tank is empty.	Check and make sure the LP tank is filled with fuel.
	Push button of safety valve was not pushed down.	Press and fully hold down push button of safety valve after the lighted match is placed on the burner.
The burner does not stay lit.	The push button on safety valve was not fully pushed down for at least 10 seconds.	Fully hold down the push button on safety valve at least 10 seconds and then release.
	Timer is not activated.	Fully turn the timer control knob clockwise.
	The thermocouple is not in direct flame path of burner.	Ensure the thermocouple is assembled in right position and the nut is tightened on the thermocouple. (See Assembly Instructions - step 2 for detail). Make sure the flame has full contact with the thermocouple.
	High wind condition.	If wind blows out flame, gas supply will be cut off. Move out of wind and restart.
	Timer has completed its cycle.	Each cycle of timer is 15 minutes, after 15 minutes, the burner will go off automatically. Please re-set the timer.
The oil is not reaching desired temperature.	The food is not fully defrosted.	Do not attempt to fry a frozen or partially frozen turkey or food. Ensure the turkey or food is completely thawed prior to proceeding.
	The regulator control valve is not fully opened.	Fully open the regulator control valve. The regulator control valve is opened in clockwise direction and the LP tank valve is opened in counter-clockwise direction.
	Overfilled Protection Device (OPD) on tank has been tripped.	Overfilled Protection Device (OPD) has been activated. To reset, turn off regulator control valve and LP tank valve. Disconnect the regulator from the LP tank and wait one minute. Reconnect the regulator control valve to the LP tank valve and slowly open the LP tank valve until it is fully open.

Product no. 085-3230-2 (TF2115708-MC-00) |

Contact us: 1-855-803-9313

1. Limited Warranty

This product carries a one (1) year warranty against defects in workmanship and materials. Trileaf Distribution agrees to replace a defective product, within the stated warranty period, when returned to the place of purchase with proof of purchase. This product is not guaranteed against wear or breakage due to misuse and/or abuse.

2. Manufacturer warrants this product to be free from defects in workmanship and materials for a period of 1 year from the date of purchase, PROVIDED claims are submitted, in writing, with proof of purchase.
3. If any part of this item fails because of a manufacturing defect within the limited warranty period, manufacturer offers to replace such part(s) provided that such parts have not been improperly repaired, altered, or tampered with or subject to misuse, abuse or exposed to corrosive conditions. This limited warranty is, however, subject to certain limitations, exclusions, time limits and exceptions (hereinafter "conditions") as listed below. Read these conditions carefully.
4. This Limited Warranty shall be limited to the replacement or repair of any part(s) which manufacturer determines, after reasonable examination, to have been defective at the time of manufacturing and manufacturer's obligation(s) shall be limited to replacement, if any, of defective part(s) which shall be shipped at original purchaser's expense to original purchaser's designated shipping address.
5. This limited warranty is given to and covers the ORIGINAL PURCHASER ONLY and such coverage terminates 1 year from the date of purchase.
6. DAMAGE LIMITATION WARNING: IN NO EVENT SHALL MANUFACTURER BE LIABLE FOR ANY INCIDENTAL OR CONSEQUENTIAL DAMAGES, INCLUDING (BUT NOT LIMITED TO) LOSS OF USE OF THE PRODUCT, LOSS OF TIME, LOSS OF FOOD, INCONVENIENCE, EXPENSE FOR TRAVEL, TRANSPORTATION LODGING EXPENSES, LOSS BY DAMAGE TO PERSONAL PROPERTY OR LOSS OF INCOME, PROFITS OR REVENUE.
7. MANUFACTURER'S OBLIGATION: Manufacturer's liability shall be limited to the delivery of a good, merchantable product and, if necessary, the repair or replacement, at manufacturer's option, of any defective part or unit.
8. TRANSFER LIMITATIONS: This limited warranty is not assignable or transferable. It covers only the original purchaser.
9. RESERVED RIGHT TO CHANGE: Manufacturer reserves the right to make changes or improvements to products it produces in the future without imposing on itself any obligations to install the same improvements in the products it has previously manufactured.
10. This limited warranty gives the original purchaser specific legal rights but there may be other rights which vary by jurisdiction.
11. This warranty does not cover the following items:
 - Chips or scratches on porcelain or painted surfaces.
 - Rust or corrosion, which is not deemed a manufacturing or materials defect.
 - Discolouration or loss of paint due to handling during assembly, heat or cleaning products. Paint may require touch-up.
 - Stainless steel discolouration or corrosion.
 - Consumables such as batteries.

Imported by

Trileaf Distribution Trifeuil Toronto, Canada M4S 2B8



Master Chef Canada
Toronto, Canada M4S 2B8