

This Owner's Manual is provided and hosted by [Appliance Factory Parts](#).



Rankam TF2034901-RG Owner's Manual

[Shop genuine replacement parts for Rankam
TF2034901-RG](#)



[Find Your Rankam Grill Parts - Select From 123 Models](#)

----- Manual continues below -----



**Cooker Stand
Assembly, Use and Care Manual**

For Outdoor Use Only

Model: TF2034901-RG



**Tools required:
Philips screwdriver / Adjustable wrench**



- **This instruction manual contains important information necessary for the proper assembly and safe use of the appliance.**
- **Read and follow all warnings and instructions before assembling and using the appliance.**
- **Follow all warnings and instructions when using the appliance.**
- **Keep this manual for future reference.**
- **This appliance is NOT for frying turkeys.**



DANGER



If you smell gas:

1. **SHUT OFF** gas to the appliance.
2. **EXTINGUISH** any open flame.
3. If odor continues, keep away from the appliance and immediately call your **FIRE DEPARTMENT**.

Failure to follow these instructions could result in fire or explosion which could cause property damage, personal injury or death.



DANGER



1. **NEVER** operate this appliance **UNATTENDED**.
2. **NEVER** operate this appliance **WITHIN 10 ft (3.0m)** of any structure, combustible material or other gas cylinder.
3. **NEVER** operate this appliance within **25 ft (7.5m)** of any flammable liquid.
4. **NEVER** allow oil or grease to get **HOTTER** than **400°F** or **200°C**. If the temperature exceeds **400°F (200°C)** or if oil begins to smoke, **IMMEDIATELY** turn the burner or gas supply **OFF**.
5. Heated liquids remain at scalding temperatures long after the cooking process. **NEVER TOUCH** cooking appliance **UNTIL LIQUIDS HAVE COOLED** to **115°F (45 °C)** or less.
6. If a fire should occur, keep away from the appliance and **IMMEDIATELY** call your **FIRE DEPARTMENT**. Do not attempt to extinguish an oil or grease fire with water.
7. The minimum environmental temperature of this appliance is **21°F (-6°C)**. Do not use this appliance under above rated temperature.

Failure to follow these instructions could result in fire, explosion or burn hazard which could cause property damage, personal injury or death.



WARNING



WARNING: FUELS USED IN LIQUEFIED PROPANE GAS APPLIANCES, AND THE PRODUCTS OF COMBUSTION OF SUCH FUELS, CAN EXPOSE YOU TO CHEMICALS INCLUDING BENZENE, WHICH IS KNOWN TO THE STATE OF CALIFORNIA TO CAUSE CANCER AND CAUSE BIRTH DEFECTS OR OTHER REPRODUCTIVE HARM. *For more information go to: www.P65Warnings.ca.gov.*



WARNING



This Appliance is NOT intended for commercial use.



WARNING



This Appliance is NOT for Frying Turkeys.

Safety Symbols

The symbols and boxes shown below explain what each heading means. Read and follow all of the messages found throughout the manual.



DANGER



DANGER: Indicates an imminently hazardous situation which, if not avoided, will result in death or serious injury.



WARNING



WARNING: Indicates a potentially hazardous situation which, if not avoided, will result in death or serious injury.



CAUTION



CAUTION: Indicates a potentially hazardous situation or unsafe practice which, if not avoided, may result in minor or moderate injury.



WARNING



- The installation must conform with local codes or, in the absence of local codes, with either the *National Fuel Gas Code, ANSI Z223.1/NFPA 54, Natural Gas and Propane Installation Code, CSA B149.1, or Propane Storage and Handling Code, B149.2.*
- Do not operate this appliance ON or UNDER any overhead roof covering, as well on or under any awning, overhang, apartment or condominium balcony, or deck.
- This appliance shall be used outdoors, and must not be used in a building, garage or any other enclosed area.
- This appliance is not intended to be installed in or on a boat and/or recreational vehicles.
- Keep appliance at least 10 ft (3m) from any combustible materials and wall. Keep at least 10 ft (3m) from such materials on the sides and back of appliance, and the appliance must not be located under overhead unprotected combustible construction. Never use under balconies made of wood or ANY overhead construction.
- Keep the fuel supply hose away from any heated surfaces.

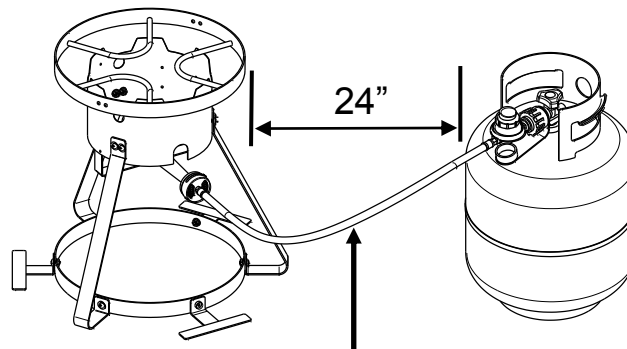
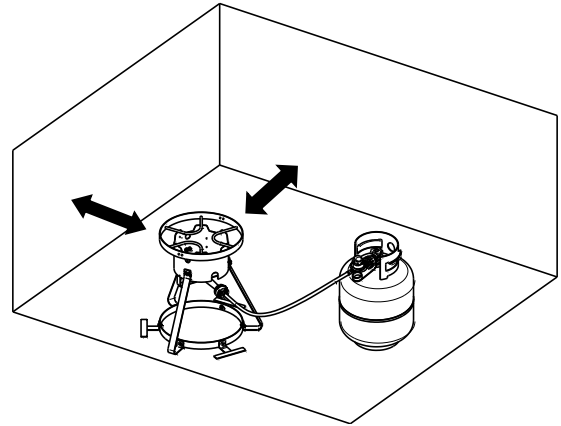

WARNING: Hose is a trip hazard.

- This appliance is NOT intended for commercial use.
- The use of alcohol, prescription or non-prescription drugs might impair the consumer's ability to properly assemble or safely operate the appliance.
- When cooking with oil or grease, have a type BC or ABC fire extinguisher readily available. In the event of an oil or grease fire DO NOT attempt to extinguish with water. Immediately call the **FIRE DEPARTMENT**. A Type BC or ABC fire extinguisher may, in some circumstances contain the fire.
- In the event of rain, snow, hail, sleet or other forms of precipitation while cooking with oil or grease, cover the cooking vessel immediately and turn off the appliance burners and gas supply. DO NOT attempt to move the appliance or cooking vessel.
- When cooking, the appliance fryer/boiler **MUST BE ON A LEVEL, STABLE NONCOMBUSTIBLE SURFACE** in an area clear of combustible material. An asphalt surface (blacktop) is not acceptable for this purpose.
- DO NOT leave the appliance unattended. Keep children and pets away from the appliance at all times.
- Do not place an empty cooking vessel on the appliance while in operation. Use caution when placing anything in cooking vessel while the appliance is in operation.
- Do not move the appliance when in use. Allow the cooking vessel to cool to 115°F (45°C) before moving or storing.

- For outdoor use only. If stored indoors, detach and leave cylinder outdoors.
- This appliance is not intended for and should never be used as a heater.
- When cooking with oil or grease, the thermometer provided **MUST** be used. Follow instructions in this manual for proper installation and use of the thermometer. If the thermometer supplied with this fryer/boiler has been lost or damaged, a replacement thermometer must be one specified by the appliance manufacturer.
- This appliance will be **HOT** during and after use. Use insulated oven mitts or gloves for protection from hot surfaces or splatter from cooking liquids.
- If the temperature exceeds 400 °F (200 °C) or if oil begins to smoke, immediately turn the burner or gas supply **OFF** and wait for the temperature to decrease to less than 350 °F (175 °C) before relighting burner according to this instructions manual.
- It is recommended that the cooking vessel not exceed 10.5QT & 12-3/4" diameter. **A BIGGER VESSEL MAY RESULT IN TIPPING.**
- Never overfill the cooking vessel with oil, grease or water than specified by vessel manufacturer instruction. If the vessel doesn't indicate the maximum fill line, please refer to following instructions for determining the maximum fill level.
Determining the maximum fill level when using a vessel without a maximum line:
 - (1) Place the food product in the basket.
 - (2) Place the food product and holder into the empty vessel.
 - (3) Fill the vessel with water just until the food product is completely submerged. There must be a minimum of 3 inch (8 cm) between the water level and top of the vessel.
 - (4) Remove the food product from the vessel and either mark the water level on the side of the vessel or measure the amount of water in the vessel.
 - (5) Remove the water and completely dry the vessel and the food product.
 - (6) This is the amount of cooking oil the vessel is to be filled with to cook the food product.
- Introduction of water or ice from any source into the oil/grease may cause overflow and severe burns from hot oil and water splatter. When frying with oil/grease, all food products **MUST** be completely **THAWED** and towel **DRIED** before being immersed in the fryer.
- Avoid bumping into or impacting the appliance to prevent spillage or splashing of hot cooking liquid.
- Never drop food or accessories into hot cooking liquid. Lower food and accessories slowly into the cooking liquid in order to prevent splashing or overflow. When removing food from the appliance care must be taken to avoid burns from hot cooking liquids.



DANGER



- The safety relief valve on the LP tank could activate the releasing of gas and cause an intense fire with risk of death or serious injury. Therefore, follow instructions below exactly.
 - A. Do not store a spare LP-gas cylinder under or near this appliance.
 - B. Never fill the cylinder beyond 80 percent full.
 - C. If the instructions in (A) and (B) are not followed exactly, a fire causing death or serious injury may occur.
- If you see, smell, or hear escaping gas, immediately get away from the LP tank / appliance and call your **FIRE DEPARTMENT.**
- All spare LP tanks must have safety caps installed on the LP tank outlet.

LP Tank Removal, Transport and Storage

- Turn OFF control knobs at regulator and LP tank valve. Turn coupling nut counterclockwise by hand only – **DO NOT USE TOOLS TO DISCONNECT**. Place dust cap on cylinder valve outlet whenever the cylinder is not in use. Only install the type of dust cap on the cylinder valve outlet that is provided with the cylinder valve. Other types of caps or plugs may result in leakage of propane.
- A disconnected LP tank in storage or being transported must have a safety cap installed as shown. Do not store an LP tank in enclosed spaces such as a carport, garage, porch, covered patio or other building. Never leave an LP tank inside a vehicle which may become overheated by the sun.
- Storage of an appliance indoors is permissible only if the cylinder is disconnected and removed from the appliance.
- Cylinder must be stored outdoors out of the reach of children and must not be stored in a building, garage or any other enclosed area.
- Turn off gas at supply cylinder when not in use.

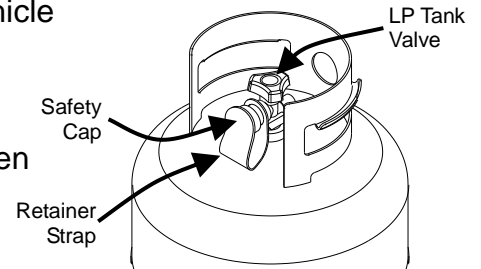

LP Tank

The LP tank used with your appliance must meet the following requirements:

- Purchase LP tanks only with these required measurements: 12" (30.5cm) (diameter) x 18" (45.7cm) (tall) with 20lb. (9kg) capacity maximum.
- The LP-gas supply cylinder to be used must be constructed and marked in accordance with the specifications for LP-gas cylinders of the US Department of Transportation (DOT) or the National Standard of Canada, CAN/CSA-B339, Cylinders, Spheres and Tubes for the Transportation of Dangerous Goods.

LP tank valve must have:

- Type 1 outlet compatible with regulator or appliance.
- Safety relief valve.
- UL listed Overfill Protection Device (OPD). This OPD safety feature is identified by a unique triangular hand wheel. Use only tanks equipped with this type of valve.
- LP tank must be arranged for vapor withdrawal and include collar to protect LP tank valve.



LP (Liquefied Petroleum Gas)

- LP gas is non toxic, odorless and colorless when produced. For your safety, LP gas has an odor (similar to rotten eggs) so that it can be smelled.
- LP gas is highly flammable and may ignite unexpectedly when mixed with air.

LP Tank Filling

- Use only licensed and experienced dealers.
- LP dealer must purge tanks before filling.
- Dealer should NEVER fill LP tank more than 80% of LP tank volume. Volume of propane in tanks will vary by temperature.
- A frosted regulator indicates gas overfill. Immediately close LP tank valve and call LP gas dealer for assistance.
- Do not release liquid propane (LP) gas into the atmosphere. This is a hazardous practice.
- To remove gas from LP tank, contact an LP dealer or call a local **FIRE DEPARTMENT** for assistance. Check the telephone directory under "GAS Companies" for nearest certified LP dealers.

LP Tank Exchange

- Many retailers that sell appliances offer you the option of replacing your empty LP tanks through an exchange service. Use only those reputable exchange companies that inspect, precision fill, test and certify their cylinders. Exchange your tank only for an OPD safety feature-equipped tanks as described in the “LP Tank” section of this manual.
- Always keep new and exchanged LP tanks in upright position during use, transit or storage.
- Leak test new and exchanged LP tanks BEFORE connecting to appliance.

LP Tank Leak Test

For your safety

- Leak test must be repeated each time LP tank is exchanged or refilled.
- Do not smoke during leak test.
- Do not use an open flame to check for gas leaks.
- Appliance must be leak checked outdoors in well-ventilated area, away from open flames or sparks.

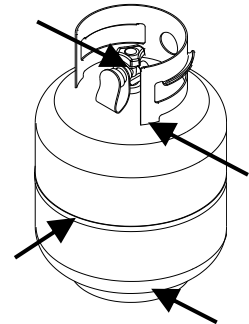

Use a clean paint brush and 50/50 soap and water solution.

Use mild soap and water. Do not use household cleaning agents. Damage to gas train components can result.

Brush soapy solution onto all metal seams and entire valve area.

Regulator Hose Assembly Check

- Before each use, check to see if there is evidence of abrasion, wear, cuts or leaks. The hose must be replaced prior to the appliance being put into operation. The replacement hose assembly must be that specified by the manufacturer.

| | | |
|-------------------------------------------------------------------------------------------------------------------------|------------------|--|
| | <h1>WARNING</h1> | |
| <p>If “growing” bubbles appear, do not use or move the LP tank. Contact an LP gas supplier or your fire department.</p> | | |

Connecting Regulator to the LP Tank

1. Place LP tank on a secure, level, and stable surface.
2. Turn control knob to the OFF position.
3. Turn LP tank OFF by turning hand wheel clockwise to a **full stop**.
4. Remove the protective cap from the LP tank valve. Always use cap and strap supplied with valve.

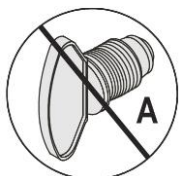
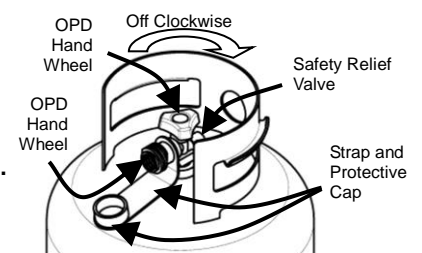

Do not use a POL transport plug (A) (plastic part with external threads)! It will defeat the safety feature of the valve.

5. Hold regulator, insert nipple (B) into LP tank valve. Hand tighten coupling nut, holding regulator in a straight line (C) with LP tank valve so as not to cross thread the connection.
6. Turn the coupling nut clockwise to tighten to a full solid stop. The regulator will seal on the back-check feature in the LP tank valve, resulting in some resistance. An additional one-half to three quarters turn is required to complete connection. **TIGHTEN BY HAND ONLY – DO NOT USE TOOLS.**

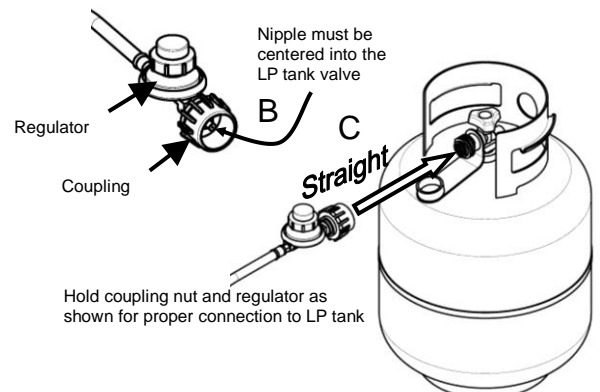

NOTE: If you cannot complete connection, disconnect regulator and repeat step 5 and 6. If you are still unable to complete the connection, **do not use this regulator!**

Disconnecting Regulator to the LP Tank

1. Turn control knob of regulator to the OFF position.
2. Turn LP tank OFF by turning hand wheel clockwise to a **full stop**.
3. Turn the coupling nut counterclockwise to loosen the connector. Loose by hand only – do not use tools.
4. When disconnected, the regulator should be hung on the hook attached to the appliance.



WARNING



- Do not insert any tool or foreign object into the valve outlet or safety relief valve. You may damage the valve and cause a leak. Leaking propane may result in explosion, fire, severe personal injury, or death.
- Never attempt to attach this appliance to the self-contained LP gas system of a camper or trailer or motor home.
- The pressure regulator and hose assembly supplied with the appliance must be the one used. Replacement pressure regulator and hose assemblies must be those specified by the manufacturer.



WARNING



- Do not use appliance until leak checked.
- If leak is detected at any time, STOP.
- If you cannot stop a gas leak, immediately close LP tank valve, leave area of appliance, and call LP gas supplier or your fire department!

Leak Testing Valves, Hoses and Regulator

1. Turn all control knob(s) to OFF.
2. Be sure regulator is tightly connected to LP tanks.
3. Completely open LP tank valve by turning hand wheel counterclockwise. If you hear a rushing sound, turn gas off immediately. There is a major leak at the connection. Correct before proceeding.
4. Brush soapy solution onto indicated connections shown below in A and B. (Reference connection of hose to burner on page 13.)
5. If “growing” bubbles appear, there is a leak. Close LP tank valve immediately and retighten connections. If leaks cannot be stopped, do not try to repair. Call for replacement parts. Order new parts by giving the serial number, number and name of items needed to the Customer Service Center at **1 – 888 – 837 – 1380**. Use only replacement parts specified by manufacturer.
6. Always close LP tank valve after performing tank test by turning hand wheel clockwise.

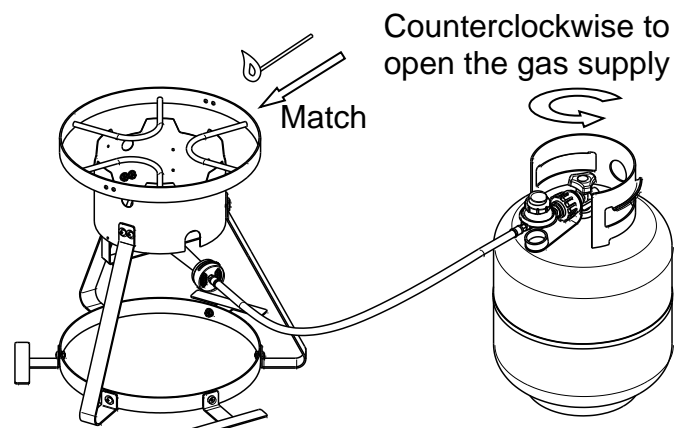
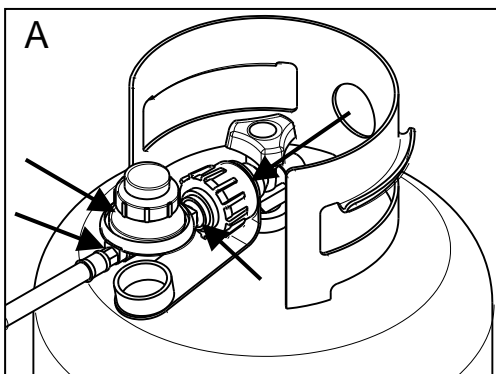

Lighting Instructions

- 1 Read instruction before lighting.
- 2 When you are sure there are no leaks, turn cylinder valve and regulator control valve on hose to the closed position.
- 3 Reopen cylinder valve fully.
- 4 Have a standard match, fireplace match or long-nosed propane lighter lit and ready to place over the burner.
- 5 Light the burner from the burner top before opening the gas supply, keeping hands and face away from open burner.
- 6 Place lighter over the burner open, then slowly open regulator valve until burner ignites.
- 7 Adjust the regulator control valve for desired flame height.
- 8 When finished using the cooker, turn off gas cylinder valve first. It will take a few second for the fire to go out and for the propane gas to “bleed” from the hose and regulator assembly. After the fire is completely out, turn regulator control valve to the “OFF” position.
- 9 To re-light, repeat steps 1 – 8. Always use CAUTION as cooker will be hot.
- 10 If ignition does not occur in 5 seconds, turn the burner control(s) off, wait 5 minutes, and repeat the lighting procedure.



CAUTION



If burner does not light OR if burner flame is accidentally extinguished, turn knob to OFF, wait 5 minutes, try again. If the burner does not ignite with valve open OR if burner flame goes out after lighting, gas will continue to flow out of the burner and could accidentally ignite with risk of injury.

Burner Flame Check

- Light Burner, rotate knob from HIGH to LOW. You should see a smaller flame in LOW position than seen on HIGH. Always check flame prior to each use. The air damper (D) mounted on the back of your burner helps to control the amount of primary air that mixes with the LP gas. A blue flame with little or no yellow flame provides the best heat. Adjust the air damper by turning it clockwise or counterclockwise until the desired flame is achieved.

Turning LP Cooker Off

- Turn all knobs to OFF position, turn LP tank OFF by turning hand-wheel clockwise to a full stop.

Hose Assembly and Regulator Check

- Cleaning and inspection of pressure regulator and hose assembly prior to use. If there is evidence of abrasion, wear, cuts or leaks, the hose assembly must be replaced prior to the appliance being put into operation. The replacement hose assembly shall be that specified by the manufacturer.

Cleaning the Burner

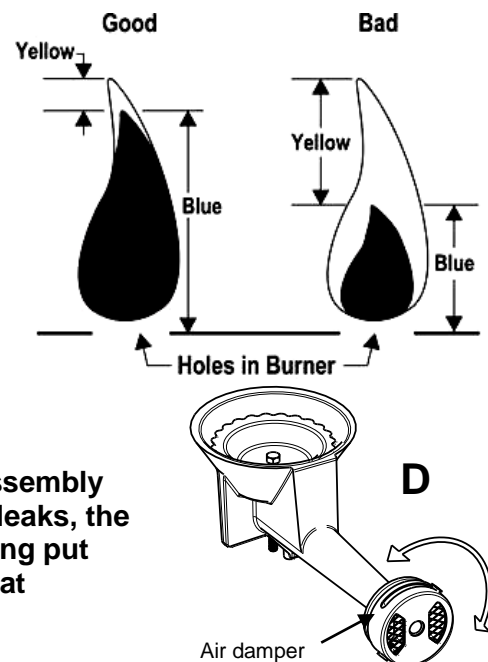

CAUTION



Check and clean burner / manifold tube for insect nests. A clogged tube can lead to fire beneath the appliances. Spiders' nests or wasps' mud inside the burner may cause fire. If a fire occurs, immediately turn off gas supply at LP tank valve. (See representative illustration in Fig.1.)

Note: Spiders and small insects can spin webs and build nests inside the burner. This especially occurs in late summer and fall before frost when spiders are most active. These nests can obstruct gas flow and cause a fire in and around the burner and orifice. Such a fire can cause operator injury and serious damage to the appliance.

To help prevent a blockage and ensure full heat output, clean and inspect burner tube often (once or twice a month). NOTE: Water or air pressure will not normally clear a spider web.

Steps for Cleaning the Burner:

1. Remove brass connector / hose from the burner.
2. Look inside the burner tube for nests, webs, or mud.
3. To remove the above obstructions, use an accessory **FLEXIBLE** venture brush or bend a small hook on one end of a long flexible wire such as the one shown in one small picture.
4. Inspect and clean the burner if needed.
5. Reattach brass connector to burner.

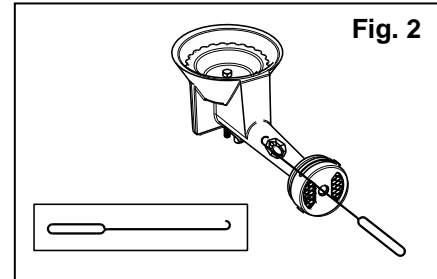
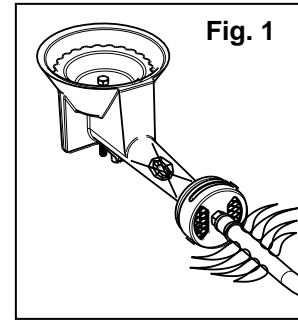

Cleaning and Maintenance

- Keep appliance area clear and free from combustible materials, gasoline and other flammable vapors and liquids.
- Do not block holes in bottom or sides of appliance.
- Check burner flames regularly.
- Use appliance only in well-ventilated space. NEVER use in enclosed space such as carport, garage, porch, covered patio, or under ANY overhead construction.
- Completely thaw meat and poultry prior to placing in hot oil.
- To minimize splattering, dry surfaces of meat and poultry prior to placing in hot oil.
- When LP tanks is connected to appliance, store outdoors in well-ventilated space and out of reach of children.
- Store appliance indoors ONLY if LP tanks turned off and disconnected, removed form appliance and stored outdoors.
- To keep the appliance clear and free from gasoline and other flammable vapors and liquids.
- Not obstructing the flow of combustion and ventilation air.
- Keeping the ventilation opening(s) of the cylinder enclosed free and clear from debris.
- Clean all cooking surfaces of vessels, aluminum pots and pan with warm, soapy water and a nylon cleaning pad to avoid oxidation, corrosion and rusting.



CAUTION



All cleaning and maintenance should only be done when the appliance is cool and with the fuel supply turned off at the LP tank. DO NOT clean any part in a self-cleaning oven. The extreme heat will damage the finish.

Correct care and maintenance will keep your appliance operating smoothly. Clean regularly as determined by the amount of use. NOTE: Clean the entire appliance each year and tighten all hardware on a regular basis (1-2 times a year or more depending on usage). Cleaning should be done where detergents won't harm patio, lawn or the like.

Suggested Cleaning Materials:

- Mild dish washing liquid detergent
- Hot water
- Nylon Cleaning pad
- Paper clip

Component Cleaning:

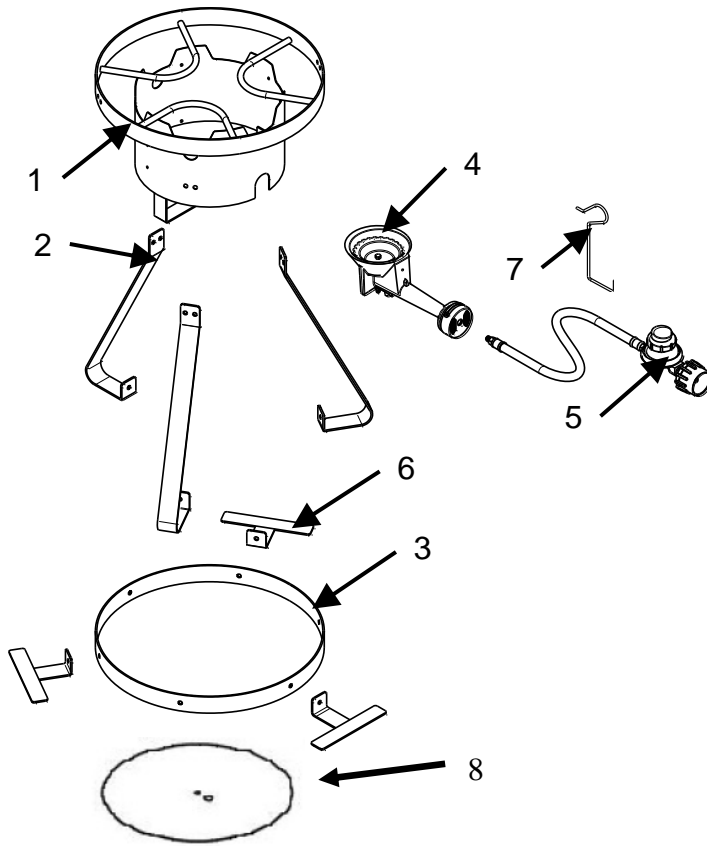

Burner: Use brush to loosen corrosion from burner exterior. Clean clogged gas port holes with an open paper clip. Replace corroded or damaged burners that would emit excess gas. For cooking surfaces like pots and pans: Clean the cooking surface with soapy water and a nylon cleaning pad.

Product Diagram

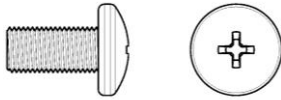

| Part# | Description | Qty |
|-------|-------------------------|-----|
| 1 | Welded Stand | 1 |
| 2 | Legs | 3 |
| 3 | Stand Ring | 1 |
| 4 | Burner | 1 |
| 5 | Regulator Hose Assembly | 1 |
| 6 | Stand Support | 3 |
| 7 | Hook | 1 |
| 8 | Heat Shield | 1 |

Hardware List

| Part# | Description | Diagram | Qty. |
|-------|---------------|--------------------------------------------------------------------------------------|-------|
| A | Bolt M6 x 12 |  | 12pcs |
| B | Flange Nut M6 |  | 12pcs |

Assembly Instructions:

1. Assemble the Legs (2) to Welded Stand (1) by using 6pcs bolts (A) and 6pcs flange nuts (B).

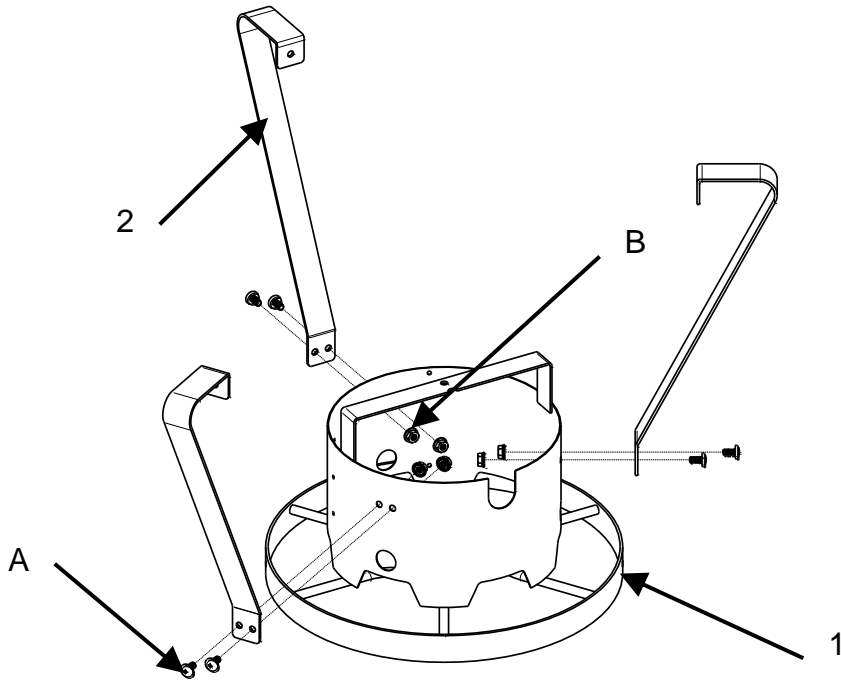

2. Assemble the Legs (2) to the Stand Ring (3) by using 3pcs bolts (A) and 3pcs flange nuts (B). Assemble the Stand Support (6) by using 3pcs bolts (A) and 3pcs flange nuts (B).

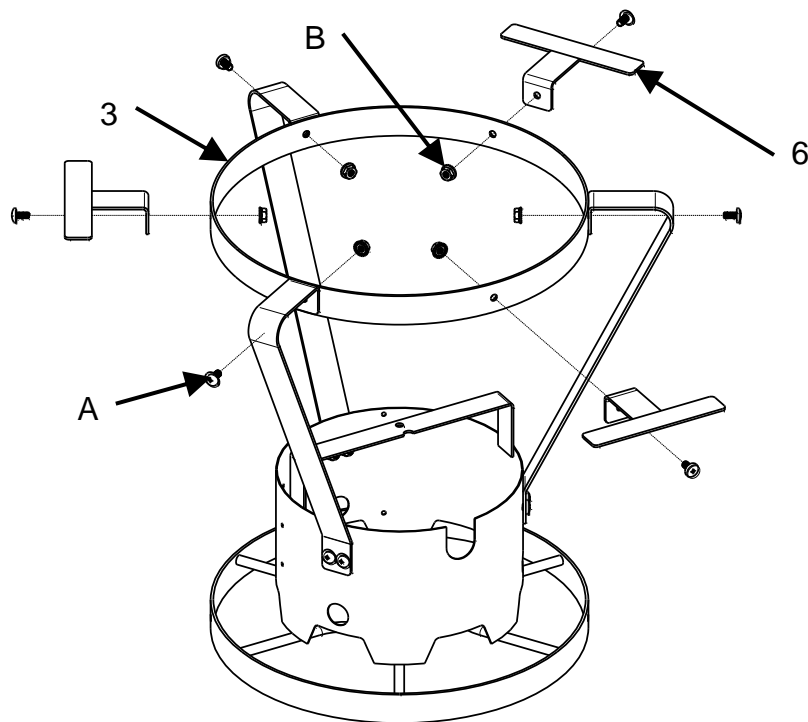

3. Insert the burner (part 4) into the cooker stand and through the cut-out opening on the side of the stand.

Insert the threaded tube at the bottom of the burner into the center hole of the burner bracket. Make sure the alignment pin seats in the notch on the edge of the burner bracket. Align with the burner pins, then fix the Heat Shield (8) outside the supporting bar and secure with the nut (on the thread pin).

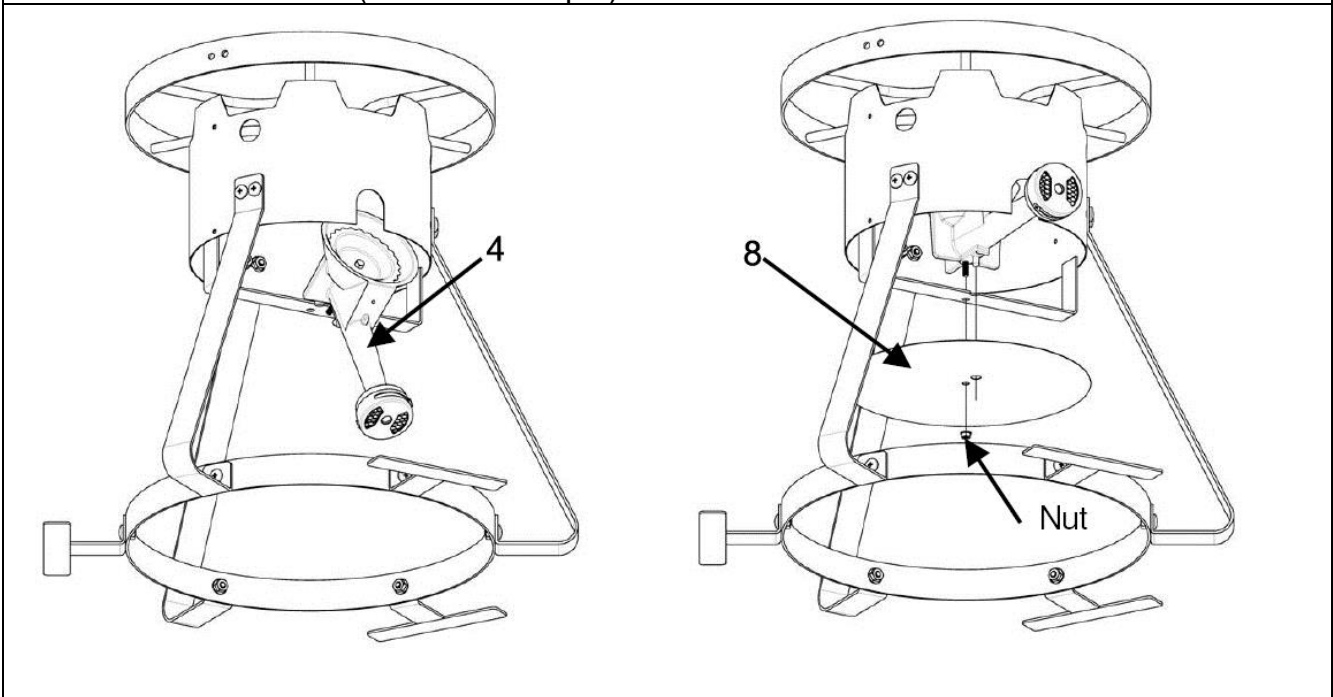

4. Insert the Regulator Hose Assembly (5) fitting into the burner and tighten. Be sure not to strip threads on brass fitting. **DO NOT OVERTIGHTEN.** Proper connection is critical for correct operation of the unit.

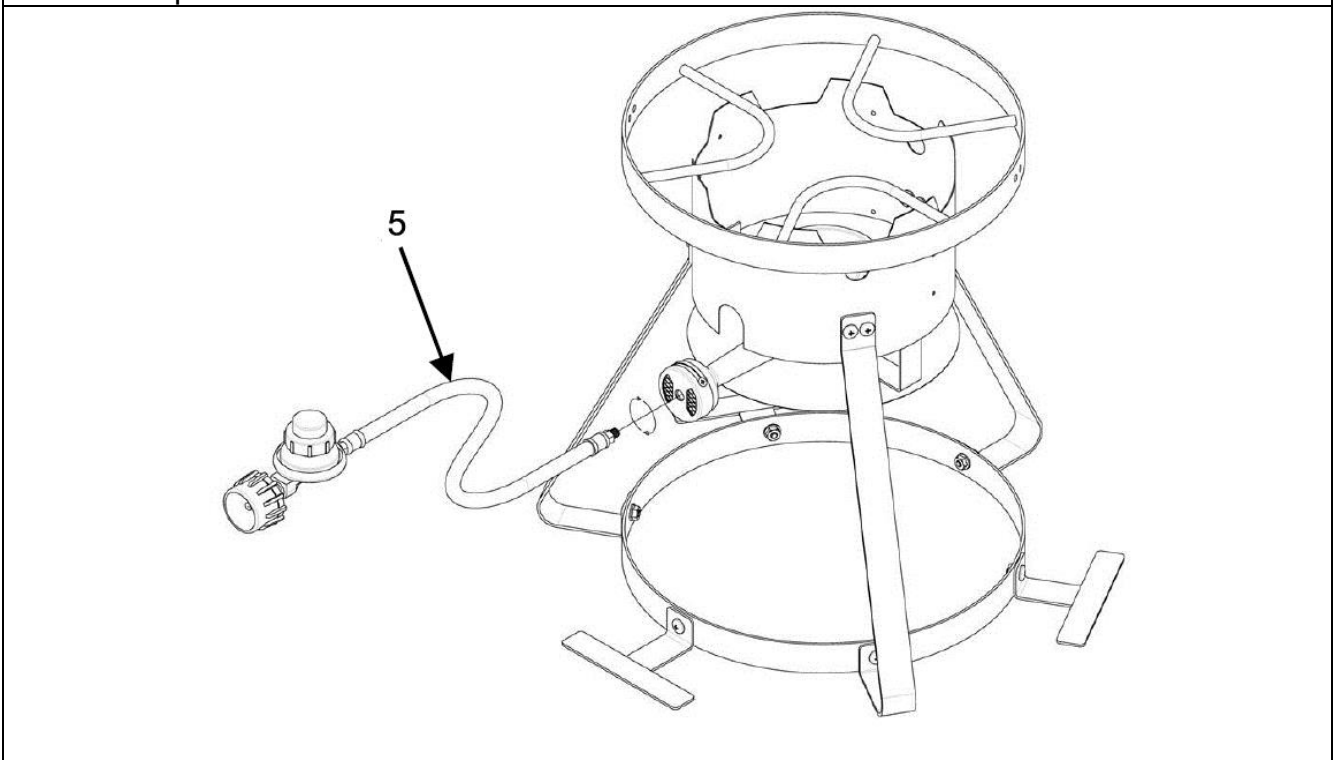

5. Thread Hook (7) through hole on side of Regulator (5).

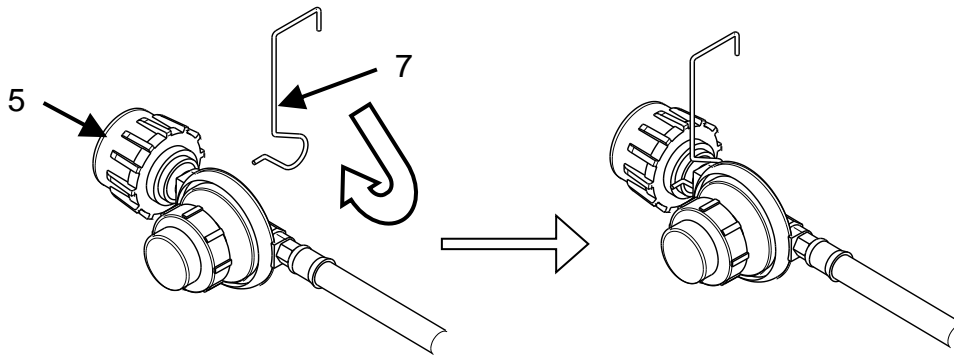

6. When transporting or storing the cooker without the LP tank attached, hook the regulator onto cooker stand to prevent damage to regulator.

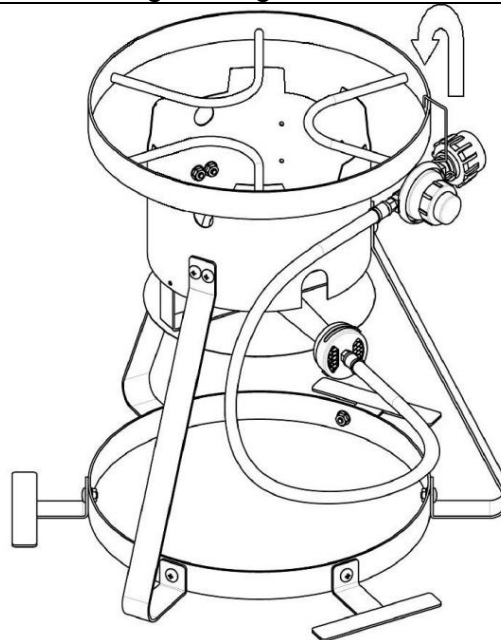

Using Your Thermometer

Check the thermometer before each use by inserting into a pot of boiling water and ensuring that it registers approximately 212°F +/- 20°F (100°C +/- 10°C). If it does not function properly, obtain a replacement thermometer specified by the manufacturer before using the appliance. Prior to lighting, position thermometer clip so that at least 2.75" of thermometer tip is submerged in oil. Reposition thermometer as necessary to cook. Continue to use thermometer until burner is turned off.



LIMITED WARRANTY

1. Manufacturer warrants this Product to be free from defects in workmanship and materials for a period of Ninety (90) days from the date of purchase, PROVIDED claims are submitted, in writing, with proof of purchase.
2. If any part of this item fails because of a manufacturing defect within the Limited Warranty Period, Manufacturer offers to replace such part(s) provide that such parts have not been improperly repaired, altered, or tampered with or subject to misuse, abuse or exposed to corrosive conditions. This Limited Warranty is, however, subject to certain limitations, exclusions, time limits and exceptions (Hereinafter "Conditions") as listed below. Read these Conditions carefully.
3. This Limited Warranty shall be limited to the replacement or repair of any part(s) which Manufacturer determines, after reasonable examination, to have been defective at the time of manufacturing and manufacturer's obligation(s) shall be limited to replacement, if any, of defective part(s) which shall be shipped at Original Purchaser's expense to Original Purchaser's designated shipping address.
4. This Limited Warranty is given to and covers the **ORIGINAL PURCHASER ONLY** and such coverage terminates Ninety (90) days from the date of purchase.
5. **DAMAGE LIMITATION WARNING:** IN NO EVENT SHALL MANUFACTURER BE LIABLE FOR ANY INCIDENTAL OR CONSEQUENTIAL DAMAGES, INCLUDING (BUT NOT LIMITED TO) LOSS OF USE OF THE PRODUCT, LOSS OF TIME, INCONVENIENCE, EXPENSES FOR TRAVEL, TRANSPORTATION LODGING EXPENSES, LOSS BY DAMAGE TO PERSONAL PROPERTY OR LOSS OF INCOME, PROFITS OR REVENUE.
6. **MANUFACTURER'S OBLIGATION:** Manufacturer's liability shall be limited to the delivery of a good, merchantable Product and, if necessary, the repair or replacement, at manufacturer's option, of any defective part or unit.
7. **TRANSFER LIMITATIONS:** This Limited Warranty is not assignable or transferable. It covers only the original purchaser.
8. **RESERVED RIGHT TO CHANGE:** Manufacturer reserves the right to make changes or improvements to products it produces in the future without imposing on itself any obligations to install the same improvements in the products it has previously manufactured.
9. This Limited Warranty gives the Original Purchaser specific legal rights but there may be other rights which vary by jurisdiction.
10. This warranty does not cover the following items:
 - Chips or scratches on porcelain or painted surfaces.
 - Rust or corrosion is not deemed a manufacturing or materials defect.
 - Discoloration or loss of paint due to handling during assembly, heat or cleaning products. Paint may require touch up.
 - Stainless steel discoloration or corrosion.
 - Consumables such as batteries.

IF CUSTOMER SERVICE BECOME NECESSARY:

1. The Original Purchaser is responsible for shipping and handling charges of the returned item(s) and replacement parts, if any.
2. All parts to be replaced will need to be shipped before replacement items will be sent.
3. Follow the Customer Service Representative's instructions exactly. If a return is necessary, it must be packed carefully and shipped prepaid.

**Should you encounter any problems,
CONTACT US FIRST, DO NOT return product to the store!**

RANKAM (CHINA) MANUFACTURING COMPANY LIMITED
18/F., New Lee Wah Centre, 88 Tokwawan Road, Kowloon, Hong Kong

CUSTOMER SERVICE: 1 – 888 – 837 – 1380

For assistance, contact customer service at **customerservice@rankam.com**
or at 1 – 888 – 837 – 1380, 8:00am – 5:00pm, Pacific Standard Time, Mon to Fri