

This Owner's Manual is provided and hosted by [Appliance Factory Parts](#).



# Pit Boss 71240 Owner's Manual

[Shop genuine replacement parts for Pit Boss 71240](#)



[Find Your Pit Boss Grill Parts - Select From 8 Models](#)

----- Manual continues below -----



**Pit Boss Kamado 22 (PB K22)**

Model # 71220 / 72220

**Pit Boss Kamado 24 (PB K24)**

Model # 71240 / 72240

# KAMADO CHARCOAL BBQ

SAVE THESE INSTRUCTIONS! COOKING TIPS INSIDE!



## PARTS LIST

Prior to assembly, check all parts against the parts list. Carry out assembly on a soft surface to avoid scratching the paint. For ease of assembly, only loosely tighten bolts and then tighten fully when assembly is complete.

**WARNING: DO NOT over-tighten bolts. Only tighten all bolts with moderate pressure to avoid damaging the bolts or components of the Kamado Grill.**

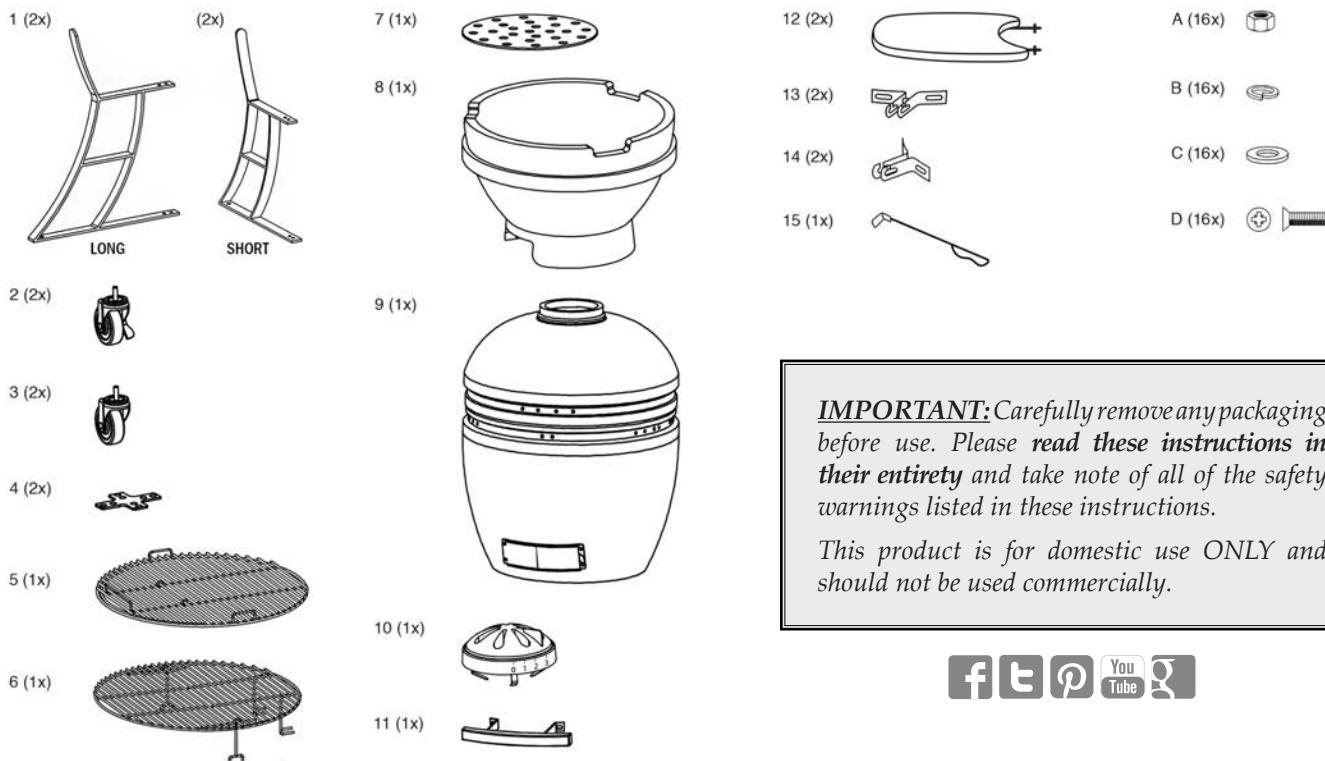

**IMPORTANT:** Carefully remove any packaging before use. Please read these instructions in their entirety and take note of all of the safety warnings listed in these instructions.

This product is for domestic use ONLY and should not be used commercially.



VISIT US ONLINE AT [WWW.PITBOSS-GRILLS.COM](http://WWW.PITBOSS-GRILLS.COM)

# CARE & SAFE USE GUIDELINES

## ABOUT YOUR KAMADO

Dating back 4000 years ago, archaeologists discovered large clay vessels, which were thought to be early incarnations of the Kamado ceramic cooker. Since then, it has evolved in many ways: removable lid, added draft door for better heat control and the switch from wood to charcoal as the primary fuel. In Japan, the Mushikamado was a round clay pot with a removable domed lid designed for steaming rice. The name “Kamado” is, in fact, the Japanese word for “stove” or “cooking range.” This name was adopted by the Americans and has now become a generic term for this style of ceramic cooker.

Kamado cookers are extremely versatile. Not only can they be used for grilling or smoking, but also pizzas, bread, pies and cookies can be baked effortlessly inside them. Due to their excellent heat retention properties, high temperatures can be achieved and maintained by precise control of airflow via the top and bottom vents. High temperatures are ideal for quickly cooking burgers and sausages, while low heats can cook larger cuts over a longer period of time. Try adding some wood chips to the charcoal, or try combining different flavour wood chips to make your meats even more flavourful.

## WARNING! CAUTION!

This product is intended FOR OUTDOOR USE ONLY. DO NOT use indoors. NEVER leave a burning fire unattended. ALWAYS keep children and pets at a safe distance from the oven when in use.

FIRE HAZARD! May emit hot embers while in use.

DANGER of carbon monoxide poisoning: NEVER light this product, let it smoulder or cool down in confined spaces.

DO NOT use this product in a tent, caravan, car, cellar, loft or boat. DO NOT use this Kamado as a furnace.

CAUTION! DO NOT use gasoline, white spirit, lighter fluid, alcohol or other similar chemicals for lighting or relighting. Use only firelighters complying to EN1860-3.

It is highly recommended that you use lump charcoal in your Kamado. It burns for longer and produces less ash, which can restrict the airflow. DO NOT use coal in this product.

IMPORTANT! When opening the lid at high temperatures it is essential to lift the lid only slightly, which allows air to enter slowly and safely, preventing any back-draft or flare-ups that may cause injury. DO NOT use under any awnings, parasols or gazebos.

ALWAYS follow the **Cooking Temperature Guide** stated in this instruction manual.

DO NOT use the Kamado on decking or any other flammable surfaces such as dry grass, wood chips, leaf mulch, or decorative bark. Ensure that the Kamado is positioned at least two metres away from flammable items.

ATTENTION! This product will become very hot. ALWAYS USE heat resistant gloves when handling hot ceramics or cooking surfaces. Allow the unit to cool down completely before moving or storing. DO NOT move it during operation.

Always inspect the unit prior to use for fatigue and damage, and replace as and when necessary.

## CURING THE KAMADO

To start a fire, place rolled-up newspaper and some lighter cubes or solid firelighters on the charcoal plate (7), in the base of the Kamado. Then, place two or three handfuls of lump charcoal over the top of the newspaper.

DO NOT use gasoline, white spirit, lighter fluid, alcohol or other similar chemicals for lighting or relighting.

Open the bottom vent and light the newspaper using a long-nosed lighter or safety matches.

DO NOT overload the unit with fuel. If the fire is too intense, the heat could damage the Kamado. Burn until all the fuel is used and the fire is extinguished.

If the first burns are too hot, they could damage the felt gasket seal before it has had the chance to mature with use.

After first use, inspect all fasteners for tightness. The metal band connecting your lid to the base will expand from the heat and this could become loose. It is recommended you check and – if necessary – tighten the band with a wrench.

You can now use your Kamado as normal.

## EXTINGUISHING

To extinguish unit: stop adding fuel and close all the vents and the lid to allow the fire to die naturally.

DO NOT use water to extinguish the charcoal as this could damage the ceramic Kamado.

## STORAGE

When not in use, and if stored outside, cover the Kamado once completely cooled with a suitable rain cover.

It is recommended the Kamado be stored under cover in a garage or shed over winter for complete protection.

## CLEANING & MAINTENANCE

The Kamado Grill is self-cleaning. Heat it up to 260°C for 30 minutes and it will scorch off all food and debris.

**DO NOT use water or any other types of cleaning product to clean the inside of your Kamado. The walls are porous and will absorb any fluids used, which could cause the Kamado to crack.**

After the Kamado has cooled, if the soot becomes excessive, use the ash tool (15) to scrape off the carbon remnants before the next use. Carefully open the bottom vent and rake the soot into a small waste container under the vent opening. Dispose of container, or store for future use (soot).

To clean the grills and grates, use a non-abrasive cleaner once the unit has fully cooled. The chrome-plated cooking grill is NOT dishwasher safe; use a mild detergent with warm water.

To clean the outer surface, wait until the Kamado is cool and use a damp cloth with a mild detergent. It is important to check and tighten the bands, and oil the hinges, twice a year or more if needed. You should not be able to easily turn a hex key while holding the nut in place.

## LIGHTING, USAGE & CARE INFORMATION

**When using the Kamado, push down on both of the locking wheels to stop the unit from moving around during use.**

Ensure the Kamado is positioned on a permanent, flat, level, heat-resistant non-flammable surface, away from flammable items.

Position the Kamado with a minimum of 2 m overhead clearance and at least 2 m clearance from other surrounding items.

1. To start a fire, place rolled-up newspaper and some lighter cubes or solid firelighters on the charcoal plate (7), in the base of the Kamado. Then, place two or three handfuls of lump charcoal over the top of the newspaper.
2. DO NOT use gasoline, white spirit, lighter fluid, alcohol or other similar chemicals for lighting or relighting.
3. Open the bottom vent and light the newspaper using a long-nosed lighter or safety matches. Once it has caught, leave the bottom vent and lid open for about 10 minutes to build a small bed of hot embers.

4. Allow the charcoal to heat up and keep it red hot for at least 30 minutes prior to the first cooking on the Kamado. DO NOT cook before the fuel has a coating of ash.

It is recommended that you do not stoke or turn the coals once they are alight. This allows the charcoals to burn more uniformly and efficiently.

5. Once alight, ONLY use heat-resistant gloves when handling hot ceramics or cooking surfaces.

Read through this manual for a complete detailed guide on cooking temperatures for grilling.

## LOW-TEMPERATURE COOKING GUIDE

ALWAYS follow the **Cooking Temperature Guide** stated in this instruction manual. ALWAYS use heat-resistant gloves when handling hot ceramics or cooking surfaces.

1. Light the lump charcoal according to the instructions above. DO NOT move or stoke the coals once lit.
2. Open the bottom vent fully and leave the lid open for about 10 minutes to build a small bed of hot embers.
3. Monitor the Kamado until it has risen to the desired temperature. Fully close the bottom vent to maintain the temperature. **See Cooking Temperature Guide.**

You are now ready to use the Kamado for cooking.

**IMPORTANT! When opening the lid at high temperatures it is essential to lift the lid ONLY SLIGHTLY at first, allowing air to enter slowly and safely, preventing any back-draft or flare-ups that may cause injury.**

## SMOKING GUIDE

Follow the instructions above as if you were starting a slow cook. Monitor the Kamado until it has risen to the desired temperature. **See Cooking Temperature Guide.**

1. Leave the bottom vent slightly open. Close the top vent and continue to check the temperature for a few more minutes.
2. Using heat-resistant gloves, sprinkle the wood chips in a circle over the hot charcoal. ALWAYS use heat-resistant gloves when handling hot ceramics or cooking surfaces.

You are now ready to use the Kamado to smoke on.

**TIP! Soak wood chips or cooking planks in water for 15 minutes to prolong the smoking process.**

**IMPORTANT! When opening the lid at high temperatures, it is essential to lift the lid ONLY SLIGHTLY at first, allowing air to enter slowly and safely, preventing any back-draft or flare-ups that may cause injury.**

## HIGH-TEMPERATURE COOKING GUIDE

Monitor the Kamado until it rises to the desired temperature. **See Cooking Temperature Guide.** ALWAYS use heat-resistant gloves when handling hot ceramics or cooking surfaces.

1. Light the lump charcoal according to the **Lighting, Usage and Care Information** in this manual. Close the lid and fully open the top and bottom vents.
2. Close the top vent halfway and continue to check the temperature for a few more minutes.

You are now ready to use the Kamado for cooking.

**IMPORTANT!** When opening the lid at high temperatures it is essential to lift the lid **ONLY SLIGHTLY at first, allowing air to enter slowly and safely, preventing any back-draft or flare-ups that may cause injury.**

## INFORMATION ABOUT COOKING FOOD

Read and follow this advice when cooking on your Kamado:

- DO NOT cook until the fuel has a coating of ash.
- Before cooking, ensure grill surfaces and tools are clean and free of old food residues.
- Always wash your hands before and after handling uncooked meat, and before eating.
- DO NOT use the same utensils to handle cooked and uncooked foods. Always keep raw meat away from cooked meat, and other foods.
- Ensure all meat is cooked thoroughly before eating. CAUTION! Eating raw or undercooked meat can cause food poisoning (e.g. bacteria strains such as E.coli). To reduce the risk of undercooked meat, cut open to ensure it is cooked all the way through.
- CAUTION! If the meat has been cooked sufficiently, the meat juice should be clear and there should be no traces of pink/red juice, or meat colouring. Pre-cooking larger pieces of meat and cuts is recommended before finally cooking on your grill.
- After cooking on your Kamado, always clean the grill cooking surfaces and utensils.

## REFUELLING YOUR GRILL

With the top and bottom vent closed, the Kamado will stay at a high temperature for several hours.

If you require a longer cooking time (e.g. when roasting a whole cut or slow-smoking), it may be necessary to add more charcoal. Open the lid, add additional charcoal, and continue to cook as directed in this manual.

## COOKING TEMPERATURE GUIDE

**IMPORTANT!** Do NOT adjust top or bottom vent while the Kamado grill is in use. This could result in serious injury. It is recommended to ALWAYS use heat-resistant gloves when working with hot appliances.

### SLOW COOK / SMOKE (83°C - 108°C / 180°F - 225°F)

Beef brisket .....	2 Hours per lb
Pulled pork.....	2 Hours per lb
Whole chicken .....	3-4 Hours
Ribs .....	3-5 Hours
Roasts .....	9+ Hours



TOP VENT



BOTTOM VENT



### GRILL / ROAST / BAKE (163°C - 191°C / 325°F - 375°F)

Seafood (crab, lobster, shrimp).....	Until opaque & firm
Seafood (clams, oysters) .....	Until shells open
Fish.....	15-20 Minutes
Pork tenderloin .....	15-30 Minutes
Chicken pieces .....	30-45 Minutes
Whole chicken .....	1-1.5 Hours
Leg of lamb.....	3-4 Hours
Turkey.....	2-4 Hours
Ham.....	2-5 Hours



TOP VENT



BOTTOM VENT



### SEAR (260°C - 330°C / 500°F - 625°F)

Scallops .....	Until opaque & firm
Steak.....	5-8 Minutes
Pork chops.....	6-10 Minutes
Burgers .....	6-10 Minutes
Sausages .....	6-10 Minutes



TOP VENT



BOTTOM VENT



# ASSEMBLY INSTRUCTIONS

**IMPORTANT: Remove all packaging before use, but retain the safety instructions and store them with this product. Ensure that the lid is closed prior to assembly.**

**STEP 1** Attach the four pre-threaded castor wheels (2 & 3) to each of the four brackets (1) by hand-tightening them into the hole.

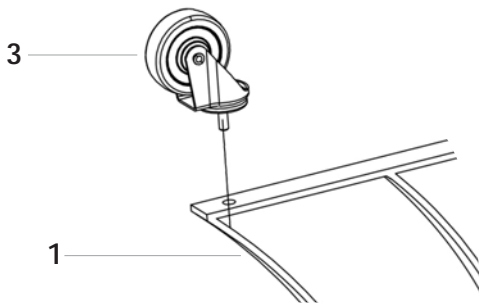

**STEP 2** To assemble the cart, attach the two crosspieces (4) to one of the four brackets (1). Secure the brackets (1) to the crosspieces (4) by using the 16x bolts, washers, locking washers, and nuts (A-D). Please note the position shown in the diagram.

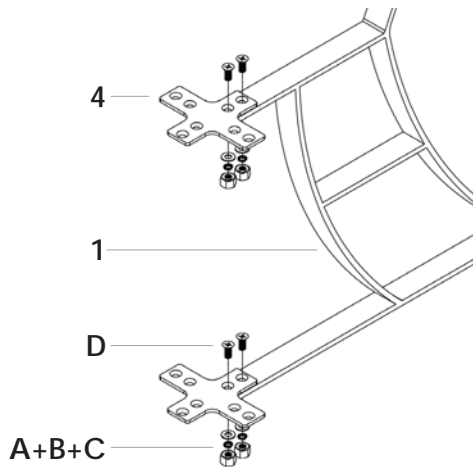

**STEP 3** Continue to attach the crosspieces (4) into the other three brackets (1).



**STEP 4** Make sure the cart is secure, and all of the bolts are tight before placing the Kamado Grill (9) into it. Press down on the castor levers (2) to lock the castor wheels to ensure the Kamado cannot move.

**STEP 5** To place the Kamado Grill (9) on the cart, first remove all of the items that are inside of the grill to make lifting easier. Place one of your hands in the bottom vent of the Kamado and the other under the grill.

**CAUTION: Use a minimum of two people when lifting the Kamado Grill onto the cart. Lifting by the hinge or the side tables could result in injury and damage to the product.**

**STEP 6** Place the Kamado Grill on the cart with the bottom vent facing to the front of the cart allowing the vent to open and close without any interruption.

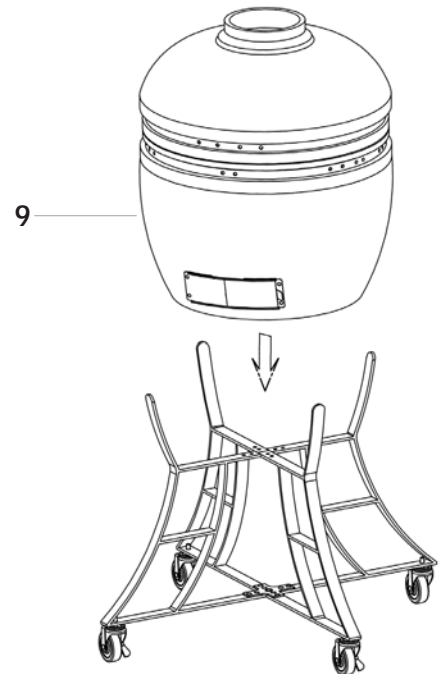

**STEP 7** Once grill is securely seated in the cart, attach the top vent (10). Align the side notch with the thermometer at the front, and set over the top opening. Secure with pre-attached bolt and nut.

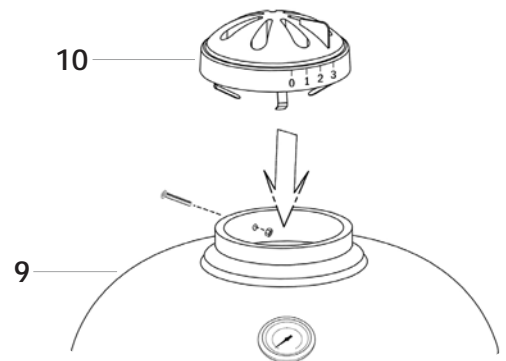

**STEP 8**

Add the firebox (8), charcoal plate (7), and cooking grill (5) inside of the Kamado Grill. Please reference the diagram below. The raised cooking grid (6) can be placed atop the cooking grill (5), if required.

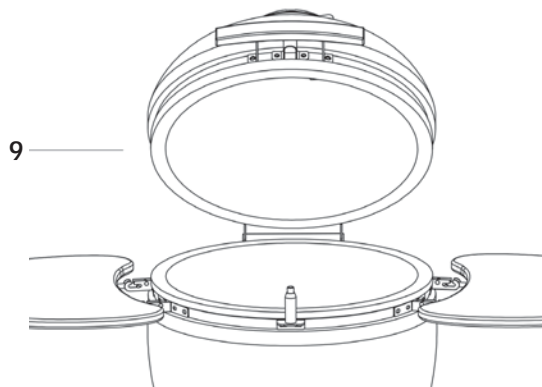
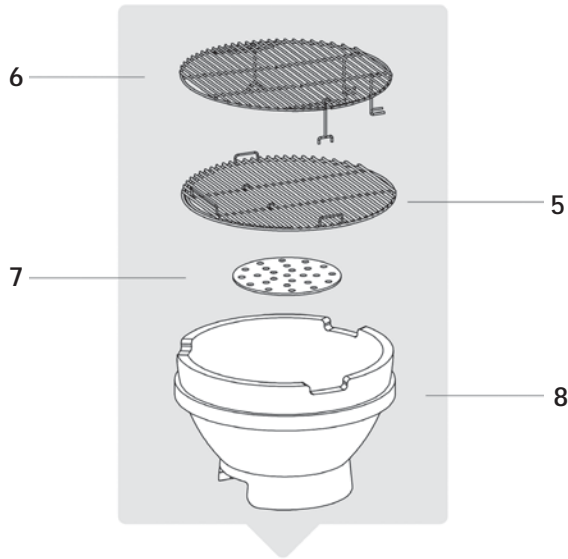

**STEP 9**

Attach the 2x table brackets (13) to the Kamado Grill (9) using the 8x pre-attached bolts with their corresponding washers, locking washers, and nuts per bracket. Please note the position shown in the diagram below.

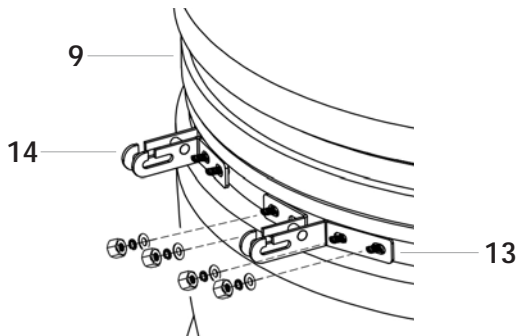

**STEP 10**

Attach the 2x table brackets (14) to the Kamado Grill (9) using the 8x pre-attached bolts with their corresponding washers, locking washers, and nuts per bracket. Please note the position shown in the above diagram.

**STEP 11**

Insert the 2x table hinges into each of the table brackets (13 & 14).

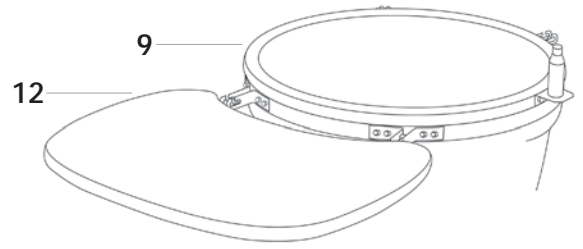

**STEP 12**

To attach the handle (11) to the lid of the Kamado Grill (9), use the 2x pre-attached bolts with their corresponding washers, locking washers, and nuts per bracket.

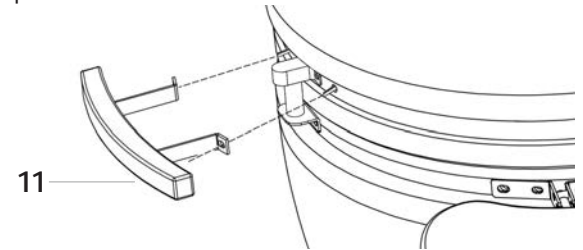

The Kamado Grill is now ready to use. Please ensure that grill curing instructions are read thoroughly prior to use.

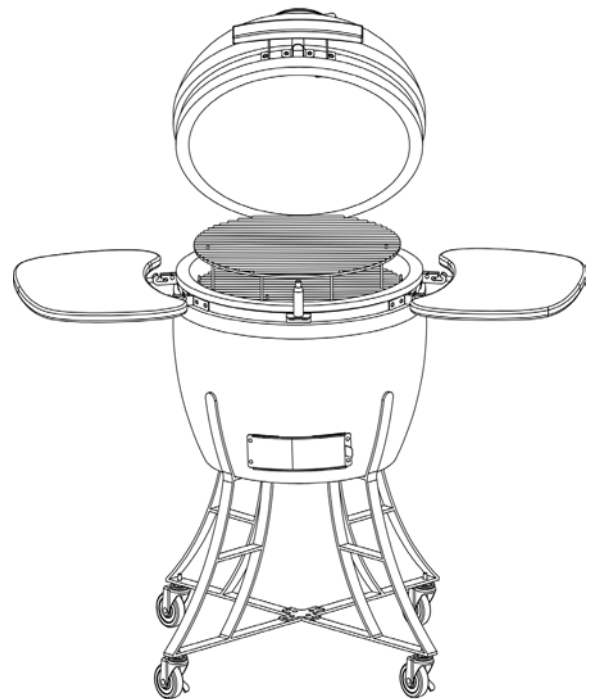

# ACCESSORIES

Available for purchase separately.

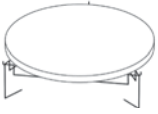

## PIZZA STONE & SUPPORT FRAME

Essential accessory for evenly cooking crispy pizzas, flatbreads and other delights.



## CHICKEN THRONE

Stand-up flavour cooked in your chicken, with your favourite choice of marinade.



## CLIP TOOL

Allows you to lift the pizza stone or cooking grills when they are too hot to handle.



## RAIN COVER

When the Kamado has cooled and is not in use, cover it with the Kamado rain cover for extra protection.

# LIMITED LIFETIME WARRANTY

## CERAMIC LIMITED LIFETIME WARRANTY

Dansons carries a Limited Lifetime Warranty on all ceramic parts used to manufacture the Kamado Grill. Dansons warrants that all part(s) are free of defects in material and workmanship, for the length of use and ownership of the original purchaser.

During the term of the limited warranty, Dansons' obligation shall be limited to furnishing a replacement for covered, failed components, F.O.B. point of shipment.

## 5-YEAR WARRANTY ON METAL PARTS

Dansons carries a five year warranty on all metal and cast iron parts used to manufacture the Kamado Grill. Dansons warrants that all part(s) are free of defects in material and workmanship, for the length of use and ownership of the original purchaser.

High temperatures, excessive humidity, chlorine, industrial fumes, chemicals, fertilizers, lawn pesticides and salt are some of the substances that can affect metal parts. For these reasons, the warranty DOES NOT COVER RUST OR OXIDIZATION.

Kindly refer to your Instruction Manual's section for proper cleaning and maintenance of your Kamado Grill. Dansons recommends that you purchase a full-length protective cover, and to cover your grill when not in use. Even with these safeguards, the Kamado Grill can be compromised by various substances and conditions beyond Dansons' control.

## VOID OF WARRANTY

The use or abuse of this product for purposes other than that for which it is designed will void the warranty.

Damage caused by lack of proper use, assembly, maintenance or installation is not covered. The pouring of lighter fluid or other liquids on your grill will void this warranty. This could result in damage or serious injury to the user of the Kamado Grill, and result in excessive damage to the grill and its many parts and components.

This warranty is only applicable if the Kamado Grill is purchased through an authorized dealer. The purchase of any product by a third party, or unauthorized dealer, voids the warranty. Only select dealers and retailers have permission, by Dansons, to sell Kamado Grill products.

## CONDITIONS OF WARRANTY

The Kamado series by Pit Boss Grills, manufactured by Dansons Inc., carries a Limited Lifetime Warranty from the date of sale by the original owner only.

The warranty coverage begins on the original date of purchase and proof of date of purchase, or copy of original bill of sale, is required to validate the warranty.

## EXEMPTIONS OF LIMITED LIFETIME WARRANTY

This warranty is based on normal and domestic use and service of the product. Damages or breakage caused by accidents, natural disasters, unauthorized attachments or modifications, or damage during transport are also not covered.

Warranty does not cover damage from wear and tear, such as scratches, dents, dings, chips or minor cosmetic cracks. These aesthetic changes of the grill do not affect its performance.

This limited lifetime warranty gives you specific legal rights and you may have other rights, which vary based on locale.

Neither the manufacturer nor the suppliers to the purchaser accept responsibility, legal or otherwise, for the incidental or consequential damage to the property or persons resulting from the use of this product. This warranty will not apply if your appliance has not been installed, operated, cleaned and maintained in strict accordance with the manual's instructions. Burning poor or low-quality charcoal may void the warranty.

All warranties by manufacturer are set forth herein and no claim shall be made against manufacturer on any oral warranty or representation. Whether a claim is made against the manufacturer based on the breach of this warranty or any other type of warranty expressed or implied by law, manufacturer shall in no event be liable for any special, indirect, consequential or other damages of any nature whatsoever in excess of the original purchase price of this product.

Some locales do not allow the exclusion or limitation of incidental or consequential damages, or limitations of implied warranties, so the limitations or exclusions set forth in this warranty may not apply to you.

Dansons does not authorize any person or representative to assume for Dansons any obligation or liability in connection with the sale of the Kamado Grill. This means that no warranties, either expressed or implied, are extended to persons who purchase the product from any one other than Dansons or an authorized Dansons Dealer.

As long as it is within the warranty period, Dansons will not charge for repair or replacement for parts returned, freight prepaid, if the part(s) are found by Dansons to be defective upon examination.

Dansons shall not be liable for transportation charges, labour costs, or export duties. Except as provided in this paragraph, repair or replacement of parts, in the manner and for the period of time stipulated hereunder, shall constitute the fulfillment of all direct and derivate liabilities and obligations from Dansons to you.

## CUSTOMER SERVICE

### WARRANTY SERVICE & RETURN POLICY

Dansons Inc. stands behind our authorized dealers. We strongly suggest that if you do need to order any parts, or options, or require service, that you first deal with your local dealer. Many dealers do stock parts and options.

If for any reason, you do not have a local dealer, Dansons Inc. is proud to offer the best technical and sales support in the industry.

For parts, options, rubs and spices, or general accessories, please contact Dansons Inc. directly.

### PARTS, SERVICE & ACCESSORIES

Contact your nearest Pit Boss Grills dealer for service, repair or replacement of your "in-warranty" parts.

Be prepared to supply the following information:

- Copy of the bill of sale.
- Purchaser's name, date of purchase, and model number of the Kamado Grill purchased.
- An accurate description of the problem.

This limited warranty gives you specific legal rights and you may have other rights, which vary based on locale.

### CUSTOMER SERVICE & SUPPORT

Our Pit Boss Grills Customer Service department is available Monday to Friday 8 am – 5pm MST.

**Do not return product to store.  
Contact Pit Boss Grills Customer Service.  
service@pitboss-grills.com**

**TOLL FREE  
1-877-303-3134**

**TOLL FREE FAX  
1-877-303-3135**

**www.pitboss-grills.com**