

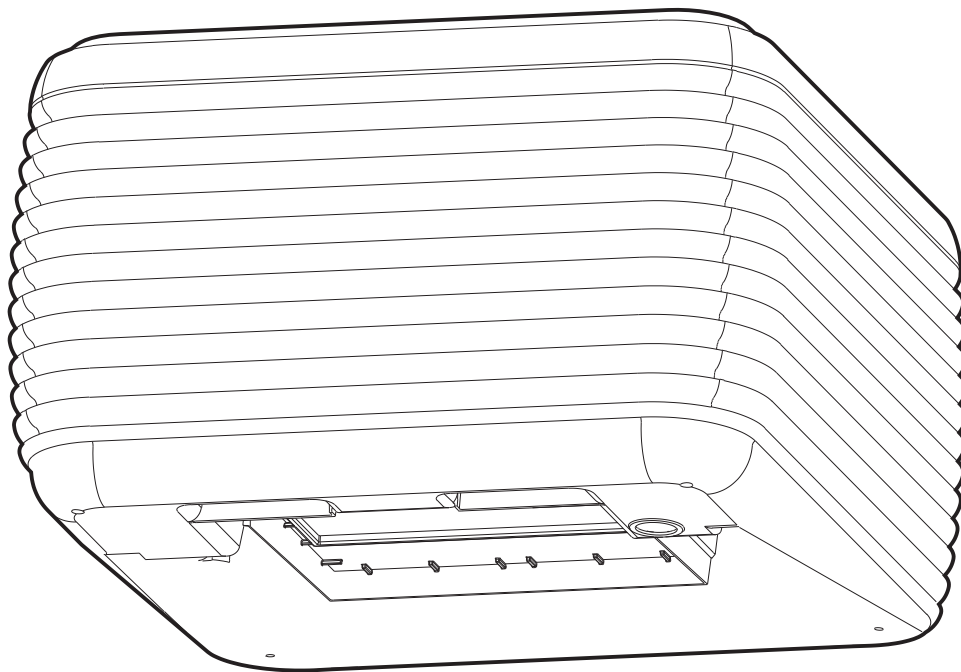

INSTALLATION & OPERATION MANUAL

EXT Evaporative Cooler



(English) (EXT)

INDEX

Safety	2
Pre-Assembly Inspection.....	3
Installation Details.....	4
Water Installation.....	5
Electrical Installation.....	6
Wiring Diagrams.....	8
Maintenance.....	9
Trouble shooting	10
Installation Checklist.....	12
Exploded View.& Parts List.....	13

Safety

SAFETY INSTRUCTIONS

Important Safety Instructions and Warnings

WARNING: The warnings and safety instructions in this manual must be followed to reduce the risk of fire, electric shock or injury, and to provide reasonable safety and efficiency in using this Evaporative Air Cooler. The operator is responsible for following the warnings and instructions in this manual and on the cooler.

Read this entire manual before proceeding to install the cooler.

This appliance is not intended for use by persons (including children) with reduced physical, sensory or mental capabilities, or lack of experience and knowledge, unless they have been given supervision or instruction concerning use of the appliance by a person responsible for their safety.

Failure to observe these warnings and instructions will void manufacturer's warranties and will discharge the manufacturer of all liability.

CAUTION!

ALWAYS disconnect the cooler from the power supply before commencing maintenance procedures.

During maintenance procedures, NEVER use a naked flame for any inspection or cleaning purpose as a fire could be caused by a flame coming into contact with the cooler materials.

Avoid Dangerous Situations: Protect the cooler from all sources of ignition because polymers and cooling pads will burn.

NEVER use a water hose to squirt the interior of the cooler for cleaning as residual water could damage electrical components and create the risk of fire and /or electric shock to the user after re-assembly.

- All installation and repair work must conform to local electrical, water supply and environmental codes, rules and regulations and applicable national standards.
- **All installation, maintenance and repair work must be done by a licensed and qualified electrician and/or a qualified, experienced heating, ventilating, air conditioning technician. All such work must be effected with factory authorized spare parts only.**

INSTALLATION, REPAIR AND OPERATION

- Disconnect electrical power at the fuse or circuit breaker box before installation commences. ALWAYS turn OFF the isolating switch (disconnect) located on the electronic module inside the cooler BEFORE commencing any maintenance procedures
- Use only the power supply voltage shown on the motor/cabinet nameplate.
- Do not install or service the air cooler during rain, high wind or severe weather conditions.
- Keep children, bystanders and animals at a safe distance, a minimum of 30ft (10m) away from working areas.
- Dress safely. Wear non-skid shoes when working at high levels and roofs. Do not wear loose clothing or personal accessories while installing or servicing the air cooler as they may become caught in moving parts.
- Keep loose hair, loose clothing, fingers and all other parts of the body away from openings and moving parts.
- Check the cooler for worn, loose, missing, or damaged parts before operation.
- If you work with power tools, wear protective eyewear and gloves.
- Take care when lifting or raising the air cooler to its final location. Use safe equipment and never attempt to lift the cooler alone. Always have assistance. Otherwise you might damage the cooler or the building or injure yourself.
- Ground Fault Circuit Interrupter (GFCI) protection should be provided on the circuit supplying this air cooler. Receptacles are available with built-in GFCI protection.
- Air coolers installed on roofs must not have the waste water directed onto the roof as stains will occur. Connect the cooler drain outlet to a gutter or drain pipe using a suitable hose.
- Always use the correct tools.
- **WARNING!** the packaging plastic on this cooler can be a safety hazard. Dispose of carefully.
- Never drill holes in the pan or walls of the cooler.
- Avoid dangerous situations. Do not use the cooler in the presence of flammable liquids or gasses to avoid creating fire or explosion. This air cooler is NOT flame retardant. A fire may result from contact with a flame or from an electrical short.
- Use of wrong replacement parts creates risk of severe electric shock and fire which may result in serious property damage, personal injury or death.

WATER PUMP

The water pump is supplied with this cooler and is factory fitted into its correct location.

Ensure that it is properly secured and upright as intended.

There is no need to adjust the water flow since the cooler is designed to operate with maximum cooling at low air velocities.

Water pump replacement

Factory authorized pumps are fitted with thermal overload protection. Water pumps may seize up and overheat, creating a fire risk. Pumps that have thermal overload protection are designed to shut off the pump if the motor overheats.

Factory Authorized water pump

Seeley "Tornado" pump (part no. 095851)

"Power Clean" Style Timed Pumps

Under no circumstances are "Power Clean" style timed pumps to be used in any Breezair evaporative air cooler. Use of these devices or any other non-approved device will cause serious damage to the special safety circuits of this cooler. **Failure to follow this instruction will VOID ALL WARRANTY and may create severe risk of electric shock and fire!**

FAN MOTOR

This cooler is supplied with a fan motor made by the cooler manufacturer. USE ONLY THE AUTHORIZED FAN MOTOR SUPPLIED.

Failure to follow this instruction will VOID ALL WARRANTY and may create severe risk of electric shock and fire!

Factory Authorized Fan Motor

Seeley 2 Speed motor:

550W (3/4HP) motor part# 113043

The fan motor is equipped with inbuilt overheating protection that will reset automatically on cool-down to a safe temperature. This may take up to 45 minutes.

CIRCUIT BREAKER PROTECTION

This cooler is fitted with circuit breaker protection for the fan motor and pump.

Pre-assembly inspection

- Check that the correct cooler has been supplied. The cooler should have the following parts:-
(Check the parts are inside the cooler by removing a cooling pad frame.)

UNIT CONTENTS (Packed inside cooler) ILL1445-A

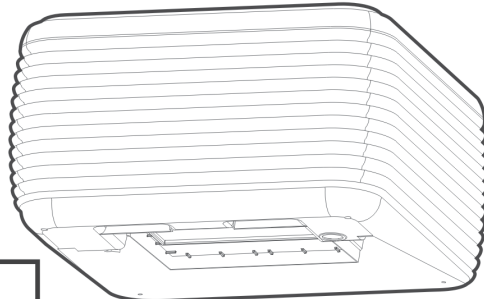

CABINET

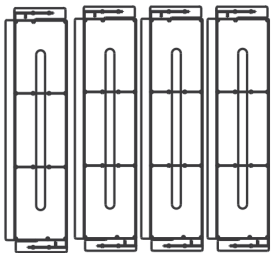

ROOF JACK ADAPTORS

MAJOR COMPONENTS (Fitted to cooler)

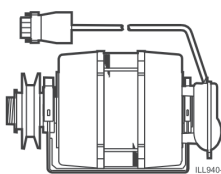

MOTOR ASSEMBLY



V-BELT

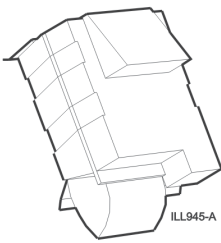

JUNCTION BOX

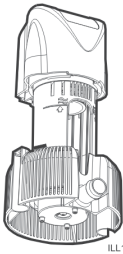

PUMP

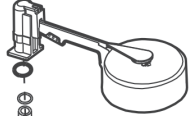

FLOAT VALVE

BREEZAIR EXT PACKOUT KIT CONTENTS

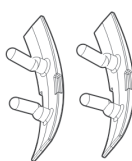

SPARE CORNER CLIPS

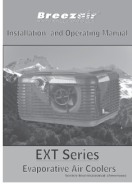

OPERATING & INSTALLATION MANUALS, WARRANTY CARD



FOOT MOUNT SCREWS



NUT 1/2" BSP & OLIVE

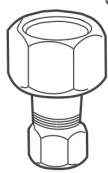

ADAPTOR 1/2" BSP to 1/4" Compression



BLEED SHIELD

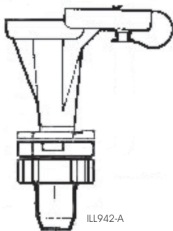

BLEED FUNNEL ASSEMBLY

Installation Details

UNPACKING THE COOLER

Cut and remove the shrink wrap from around the cooler. Using 2 people, carefully lift the cooler up and away from its skid (Fig 1).

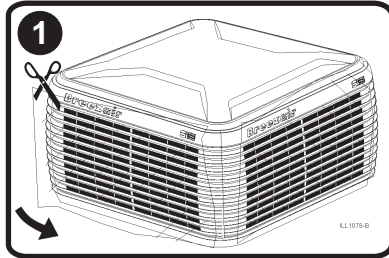

REMOVING PAD FRAMES

Firstly remove the corner clips, which are located above the top louvre and third louvre from the bottom on all corner joins. The clips will require a screw driver to aid removal.

Each frame is clipped into the cooler and is removed by use of a medium sized screwdriver. Insert the screwdriver into the small slots at the top of the frame and lever upwards until the clips disengage. The frame is now free to be lifted out of the cooler cabinet (Fig.2).

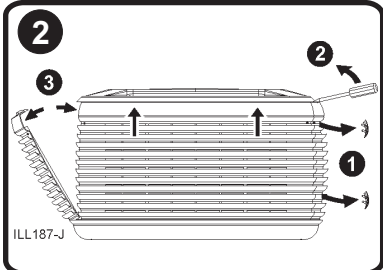

REPLACING PAD FRAMES

Ensure the pad frame is the correct way up by checking that the louvres face upwards. Fit the frame in at the bottom along the edge of the pan and rotate it in at the top. Take care not to damage the Chillcel as the frame approaches the plastic water spreader under the top panel. Then two sharp hits by hand should locate the frame into its correct location under the top panel. Replace the pad frame clips at the corners

COOLER LOCATION

Check the proposed cooler location first, to ensure it is structurally capable of supporting the weight of the cooler. Polymer coolers are light-weight but they require adequate support. The largest cooler in the EXT range is about 185 lbs (84 Kgs).

Always locate the cooler where there is a plentiful supply of clean fresh air, and not in a recess or close to the ground where the air may be dusty or polluted. **Keep the cooler away from heater flues, exhaust vents (especially kitchens) and sources of ignition. Avoid dangerous situations.**

Allow for adequate, SAFE access around the cooler for maintenance, especially for pad cleaning, water connections, electrical connections, drain connections.

It is mandatory that water cannot enter the building as a result of poor sealing (caulking or flashing) of the various penetrations into the building (ducts, necks, water pipes, electrical conduits).

The cooler must be mounted at least 10ft (preferably 15ft) away from the closest element of any TV antenna. Make sure the cooler is not between the antenna and the transmission tower that is providing the television signal to the home. Ensure that all antenna cables are at least 10ft from the cooler.

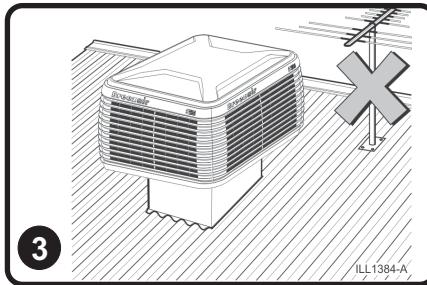

MOUNTING THE AIR COOLER.

Handling and installing the cooler is always much easier if you remove the pad frames first.

New installation, roof jacks

Use 24 G or stronger metal roof jack. The cooler may then be attached directly to the jack.

Replacement installation, roof jacks

Roof Jack recommended wall thickness should be 24 G steel or stronger. The supplied roof jack adaptor may be required to attach the cooler to the existing roof jack. For assembly of the roof jack adaptor, see Fig. 4.

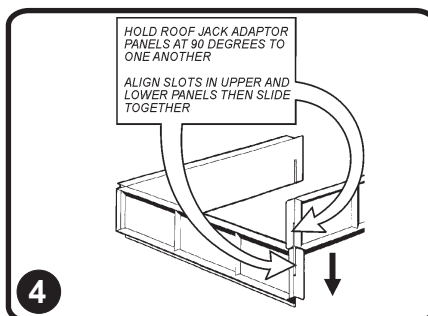

NOTE! It is recommended that a strip of foam or sealant is applied to the upper flange on the roof jack before securing the cooler to provide an airtight seal.

Ensure that the top of the roof jack is level, then check the lip of the pan for level when the cooler is in position on the roof jack. (Fig. 5)

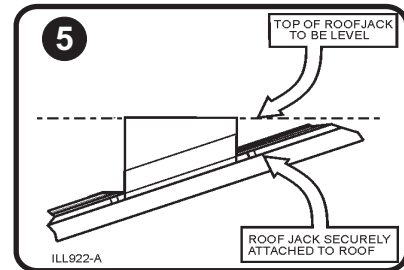

RAISING COOLER TO IT'S FINAL LOCATION

HANDLE WITH CARE. DO NOT DROP.

For lifting or pulling the cooler, always apply the ropes around the full cabinet or the fan housing and NEVER tie them to any of the four corner posts.

WARNING! Take care when moving the cooler that nothing is allowed to penetrate into the discharge opening (such as the end of a ladder), as damage may occur to the internal cooler components. If a ladder is used as a slide for the cooler to be pulled onto a roof or platform, we strongly recommend the cooler be turned upside-down first. Protect the lid from scratching.

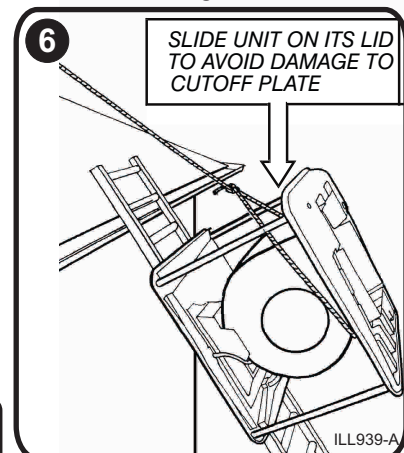

After placing the cooler on the roof jack check that water spreaders and other internal components are all securely in place.

Installation Details

Attach the cooler to the roof jack from inside the cooler (Fig. 7), using 1 1/4" long self-tapping screws. Use a minimum of six (6) screws. In high wind areas or when not using leg supports use a minimum of eight (8) screws, 3 per side and 2 at the front.

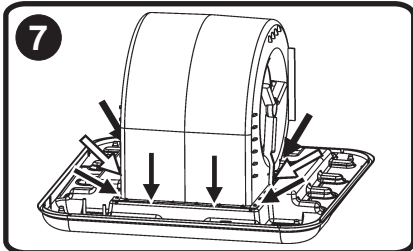

The sump of the pan is designed to be located on the low side of the roof (Fig. 8)

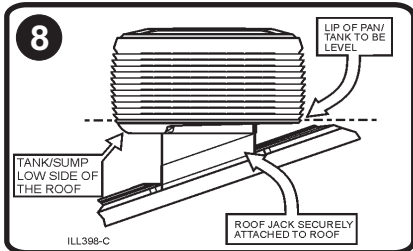

SECURING LEG SUPPORTS

After levelling and securing the cooler onto the roof jack you are ready to fix the four leg supports. The telescopic leg supports (with feet attached) slide up and down inside the four cooler corner posts. By removing the screw from the lower end of the corner post you enable the leg support to slide down to roof level. Refer figs 9, 10 & 11 for the procedure for adjusting and securing the leg supports.

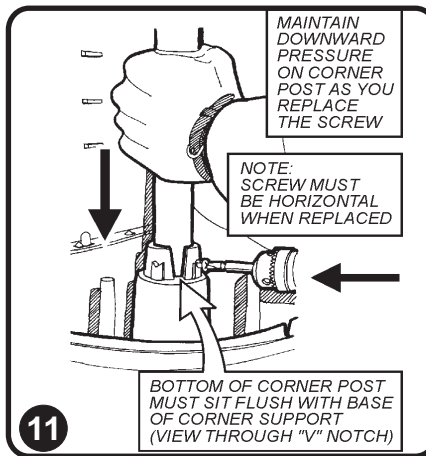
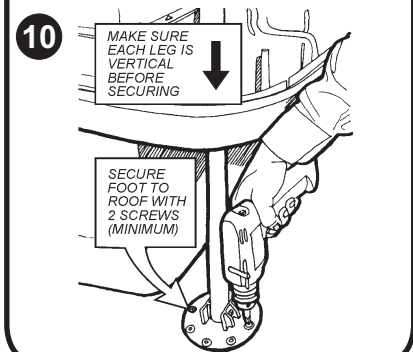
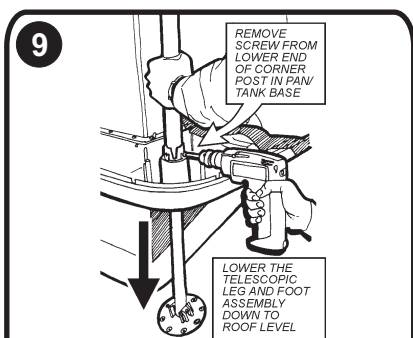

The support legs are not full weight bearing and are only intended for additional support in case of high winds, etc.

Water installation

A permanent water supply is required to be connected to the water inlet solenoid valve assembly that is supplied with the cooler. The float valve then controls the water level in the pan automatically. (Fig. 12)

The water connection point is located underneath the pan where the 1/2" float

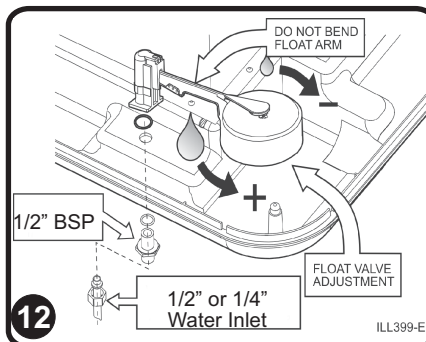

Install a manual water shut-off valve near the point of entry of the water supply to the cooler, in the permanent water supply. In areas subject to winter freezing, install a drain down feature. **DO NOT FIT SHUT OFF VALVES DIRECTLY ONTO THE FLOAT VALVE NIPPLE OR SOLENOID VALVE.**

WARNING!: Flush foreign matter from water supply pipe before final connection to the flexible hose, to avoid damage to the water solenoid and float valve.

Overflow & Bleed Off Feature

A special "bleed-off" fitting is supplied with the cooler. It has a 3-fold function: it acts as an overflow, a drain and a bleed-off.

If the water level gets too high the excess water overflows into the fitting and away to waste.

If the user wants to drain the pan he can lift the fitting out of the drain hole and the pan water will run away to waste. The bleed function must always be commissioned, except in areas where it is illegal to run water to waste. The continuous bleeding of a small amount of water to drain forces fresh water to enter the cooler and reduces the rate at which salt and scale build up on the pads. The bleed-off fitting is inserted into the large hole already formed in the pan. (Fig. 13). Screw the tank nut firmly under the pan by hand.

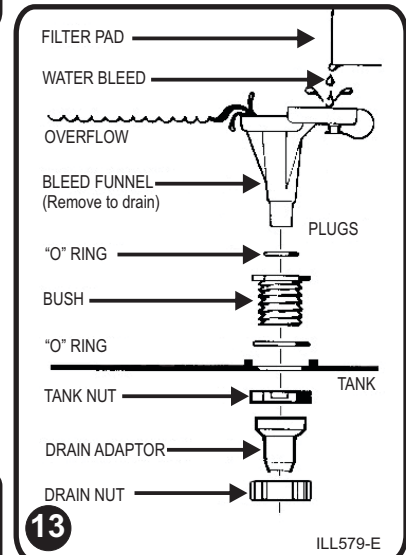

Make sure the fitting is located correctly in relation to the pads and that the large O-ring is on before placing the fitting into the hole in the pan. Secure with clips provided. (Figs. 13 & 14)

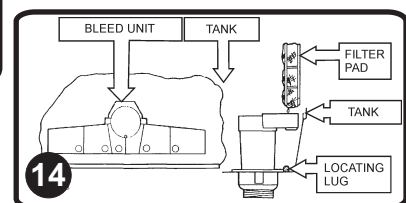

The drain adaptor allows the attachment of a 3/4" drain hose to run water to a waste point. Attach it to the bleed fitting underneath the pan by using the drain nut. (Fig. 15)

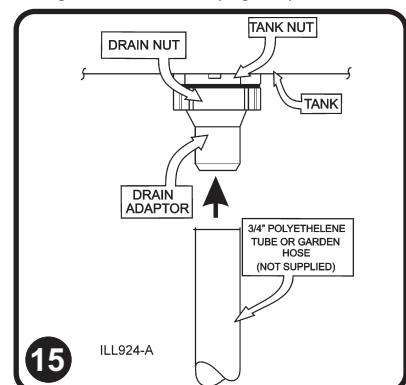

Installation Details

The bleed rate can be varied according to local conditions. With all the plastic plugs removed from the tray, minimum bleed will occur. Insert plugs to increase the bleed rate to suit your salt build up experience. See heading Operating Adjustments for further details.

In those areas where draining of bleed-off water is illegal, the bleed must be disabled.

WARNING! In cases where bleed-off is not used the pads will require frequent inspection and replacement. Failure to do so may cause water to leak into the building or onto the roof, which may enter electrical components creating an electric shock or fire hazard. Where this condition is allowed to exist, Seeley International (Americas) accepts no responsibility for any damage or injury that might occur.

WATER LEVEL ADJUSTMENTS

Water level:

The water level in the cooler is important. Adjust the level at the float valve inside the cooler. Rotate the large plastic float CCW or CW to change the level. CW will lower the level; CCW will raise the level. (Fig. 17)

NEVER ADJUST THE WATER LEVEL WITH THE COOLER RUNNING

because the residual water in the pads and pipes will cause the water to overflow when it runs back into the pan. Water level should be about 1/4" above the float valve support shelf. (Fig. 18)

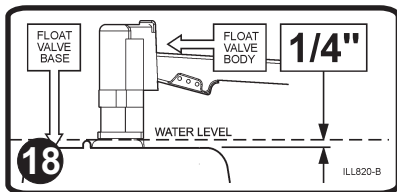
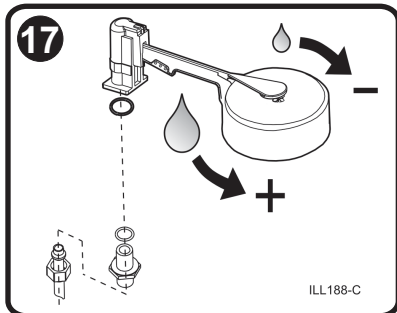

ELECTRICAL INSTALLATION

WARNING! When retro-fitting the cooler to an existing installation always turn off the electrical power at the source of the wiring. **DO NOT TAKE RISKS!** Turn off and tape over the circuit breaker or remove the fuses and keep them with you until the job is complete. Set cooler, isolator switch, wall switch, motor and pump to "off". Be sure to tell other occupants of the building what you are doing.

WARNING! Check to be sure that the voltage rating of the cooler matches your electrical system voltage.

The electrical installation must be carried out by a licensed and qualified electrician. Wiring to the cooler must be rated at cooler rated amperes or higher, and must be protected by a suitable fuse or circuit breaker. Cables are to be double insulated all the way into the cooler junction box.

Ensure that all electrical connections are tight. Loose connections will cause overheating that may lead to machine damage or fire.

Replace all covers on completion of the work, using only the screws supplied.

Do not tamper with factory wiring.

Before leaving the job, a trained, licensed technician must check that the cooler is operating correctly, **and must set the motor full load amps using a clip-on ammeter.** Make this adjustment at the motor pulley (sheave). See later detail under heading "Operating Adjustments".

The Power Pack fitted in this cooler contains a junction box with main power supply termination box attached. (Fig. 19)

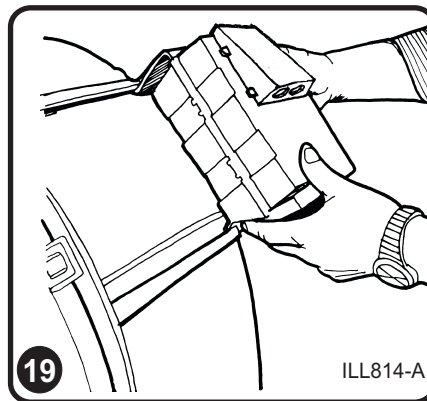

A screw is required to lock the junction box into position. (Fig. 20)

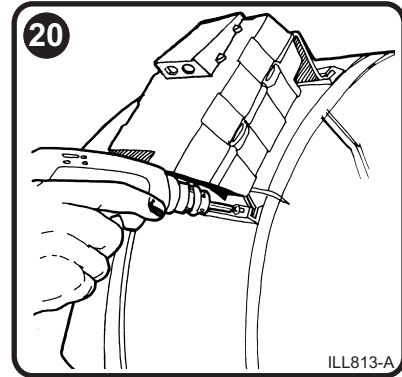

The main power termination box is made in two sections to facilitate easy wiring connections. Knock-outs are provided for 1/2" conduit. A hole must be drilled for 3/4" conduits. (Fig. 21)

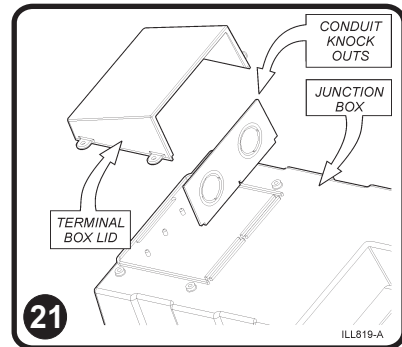

Connect the power supply and control cables inside this termination box as shown on wiring diagram/s on page 7.

The junction box is factory sealed; do not attempt to open it; there are no field serviceable parts inside.

The junction box contains plug receptacles for fan motor, water pump, and other optional features if used.

Fan motor amperes must be adjusted **before closing the termination box** using a clip-on ammeter on the power wires.

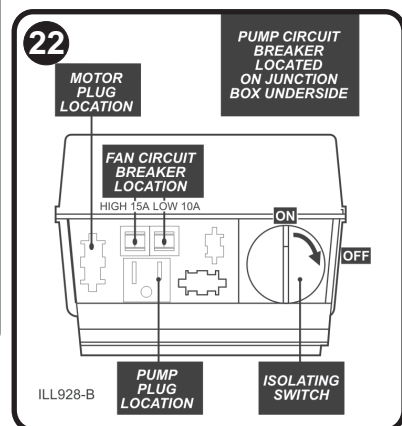

Installation Details

MOTOR POWER (AMPS)

Important: Install all the pad frames except the one on the motor side.

Ensure that all intended doors, windows or other means of exhaust are open in the building, and that all outlet grilles are open fully.

WARNING: Beware of rotating fan, belt and pulleys whilst making adjustments to motor speed, pulley or belt tension settings. Ensure the cooler is switched OFF via the electronic module isolation switch whilst working inside the cooler.

Set the cooler running at the highest speed for about 10 minutes, or until the motor has reached its normal operating temperature (hot!). **Motor load must be checked without the pump running.**

Clip your ammeter onto the free cable in the main termination box. (Fig. 25) **This should be done by a trained licensed electrician.**

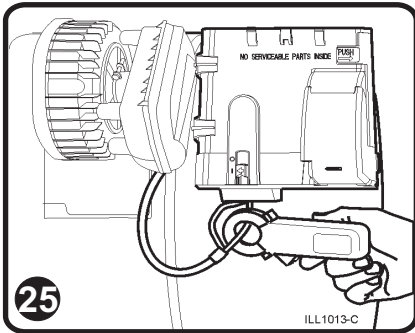

For convenience, the rated motor current, in amps, is printed on a small label attached near the cable fork (in addition to the normal motor nameplate label located at the back of the motor).

Check the measured amps against the **motor nameplate amps**. If the measured amps are less than the nameplate amps the adjustable motor pulley sheave must be altered to increase the fan speed, thereby delivering the full capability of the cooler to your installation. **The measured amps must be equal or close to, but never more than the nameplate amps. (see heading "Pulley (Sheave) Adjustment")**

If the measured amps are greater than the motor nameplate amps the fan **MUST** be slowed down by adjusting the motor pulley sheave in the opposite manner.

Failure to do this will cause overheating in the motor and may cause the motor's thermal protector to trip. Replace all covers when adjustments are completed using the screws provided.

PULLEY (SHEAVE) ADJUSTMENT

The motor pulley is adjustable in order to set the motor amperes at the correct (nameplate) level, and thus provide the owner with full machine cooling capacity.

DO NOT USE THE PULLEY ADJUSTMENT TO SET BELT TENSION.

The adjustment is made with the cooler switched OFF. Never attempt this procedure with the cooler operating.

Remove the drive belt.

To increase the fan speed (and therefore the motor amps), the two halves of the pulley must be closer together, ie: turn the adjustable half clockwise. (Fig. 26)

To decrease the fan speed (and therefore the motor amps), the two halves of the pulley must be further apart, ie: turn the adjustable half counter-clockwise. (Fig. 26)

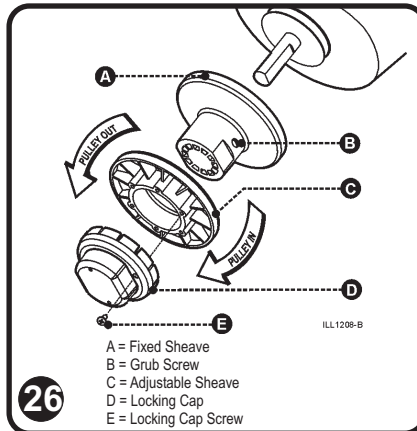

The outer half of the pulley is on a thread and can be moved in or out by removing the locking cap and then turning the outer half by hand in the desired direction.

When an adjustment is made, replace the locking cap, aligning the screw hole with the nearest hole in the adjustable half. Lock it into place with the securing screw. Refit the belt, reset the belt tension, then run the cooler and check the amps. Repeat the process until the amp level is set.

You can start and stop the cooler for this procedure by using the isolating switch inside the cooler.

BELT TENSION

Belt tension is important. If it is too tight there will be excessive belt and bearing wear. If it is too loose there will be belt slip, excessive belt wear and loss of cooler performance. There are two adjuster bolts with locking nuts attached to the motor mounting.

The tension should be adjusted so that the deflection on one side of the belt is 5/8" to 13/16". To make the adjustment, loosen the locking nuts and screw the bolts in or out as required to change the belt tension. Re-tighten the locking nuts.

It is important to recheck the motor amps again after re-setting the belt tension.

Correct belt tension ensures the belt will not slip. Check the temperature of the belt by hand after each adjustment, by turning off the cooler and holding one side of the belt in your hand. If the belt is warm to touch, it is slipping! Continue to tighten until it runs cool. (Fig. 27)

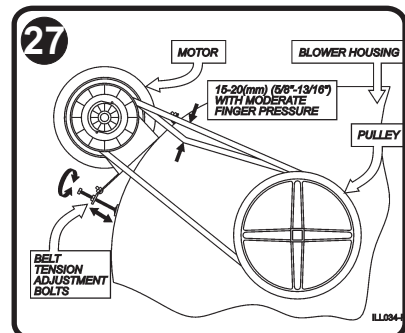

BLEED OFF

See previous heading "Overflow and Bleed-Off feature" under "Water Installation".

Adjusting the bleed rate is necessary to reduce the salt deposit on the pads. Salt deposit can NEVER be entirely eliminated, only the rate of deposit can be changed. The bleed feature causes some salt concentrated water in the pan to be drained away. Fresh water enters the cooler automatically as the salty water exits.

The rate of bleed will vary according to water quality, but should be set to a minimum rate as set out below:-
EXT155 (small cabinet): 0.08 gpm

EXT265 (large cabinet): 0.13 gpm

NOTE! Bleed adjustment cannot be precise as operating conditions vary continually.

NOTE! Previous warning about running coolers without bleed-off.

Wiring diagrams

Wiring Option 1

Fig. 24 shows the field wiring for a 2 speed cooler WITH LINE SUPPLY WIRED FIRST TO THE COOLER (not first to the wall control).

NOTE! the cooler must be connected in this way for successful operation of the optional Salinity Manager/Auto-Drain feature, as it requires a constant source of power.

Wiring Option 2

Fig. 25 shows the field wiring for a 2 speed cooler WITH LINE SUPPLY WIRED FIRST TO THE WALL CONTROL (not first to the cooler).

NOTE! Option 2 will not support the optional Salinity Manager/Auto-Drain feature.

FOR INFORMATION CONCERNING OTHER WIRING CONFIGURATIONS CALL BREEZAIR TECHNICAL DEPARTMENT. (800) 926-6824

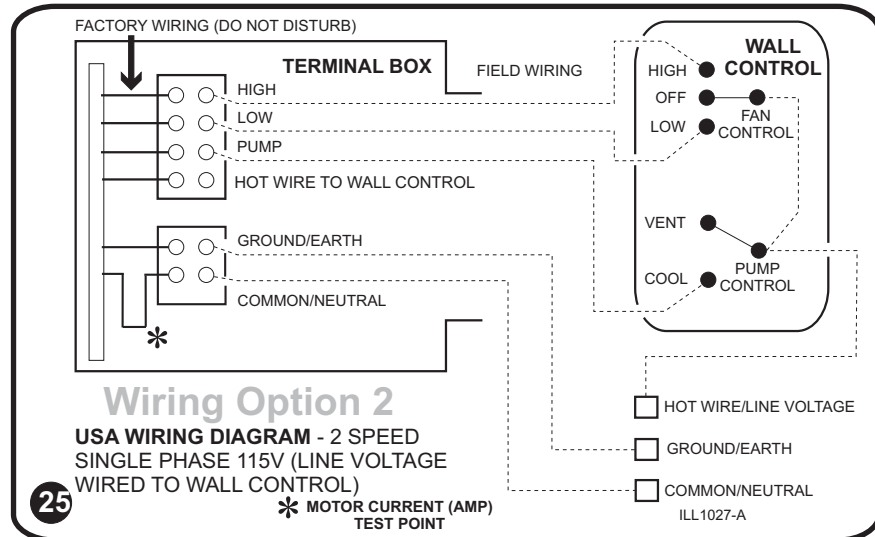
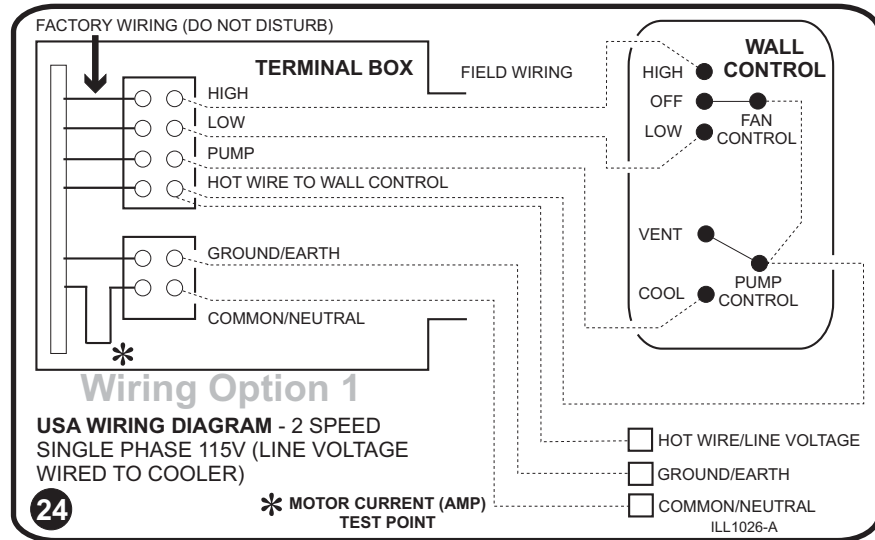

Reset Pump Circuit Breaker 2 speed Coolers ONLY:

- (1) Disconnect power supply at the main panel.
- (2) Remove the junction box from the blower housing.
- (3) Invert the junction box and locate the circuit breaker.
- (4) Press the button until it "clicks" and remains in. (Fig 26).
- (5) Reposition the junction box on the blower housing (ensure locking screw is reinstalled. Fig 28).

Should a 2 speed motor overload, one of the circuit breakers will trip, showing a white button. To reset, press this white button until it "clicks" and remains in.

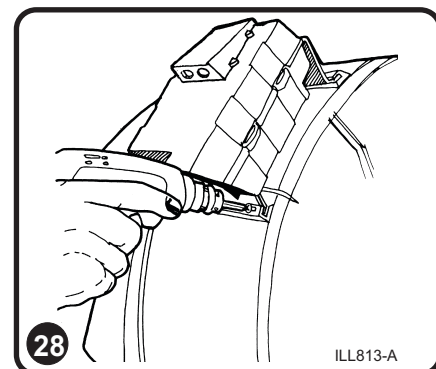
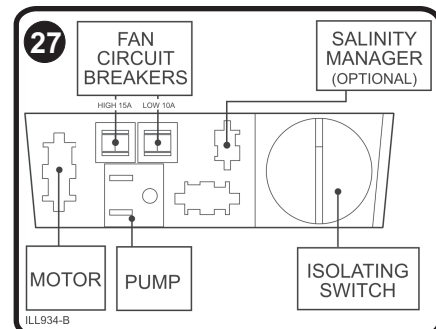
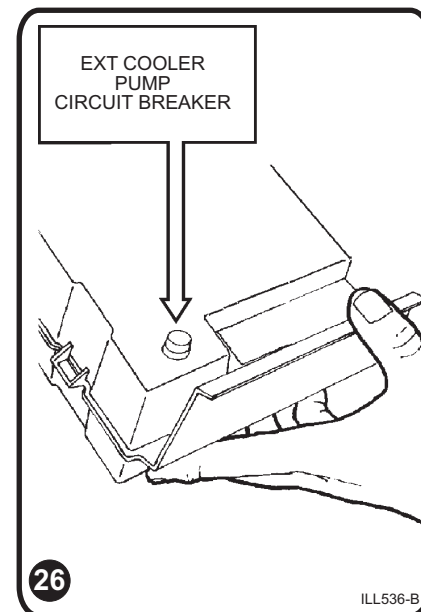

Operation of cooler

Using your Cooler:

Evaporative air coolers always function on 100% fresh outside air.

Therefore you must either open doors and windows, or, provide exhaust outlets in the building. **FAILURE TO PROVIDE ADEQUATE EXHAUST OPENINGS WILL CAUSE A BUILD UP OF HUMIDITY INSIDE THAT WILL BECOME VERY UNCOMFORTABLE.**

Start up

- Turn on the water supply and make sure the shut off valve at the cooler is also on.
- Turn on electrical power supply.
- Wait a few minutes for the water to fill the cooler pan.
- Turn on "cooling" at the wall control to start the pump and pre-wet the pads.
- Turn on the fan to High or Low speed as desired.
- In humid weather you may feel more comfortable by turning off the cooling to run the fan only.
- You can create your own pattern of air flow in the building by adjusting the outlet vents and doors and windows to direct the air where you want it.

Maintenance instructions

Pre-season Maintenance:

NOTE! All maintenance must be done by a trained, licensed technician.

- Turn off the power supply to the cooler.
- Remove pad frames
- Turn off the isolating switch inside the cooler.
- Fit new pads if necessary.

The life of Chillcel pads is generally longer than traditional Aspen pads. However the life depends on running hours, quality of environment, weather and water quality. **The pads supplied have been selected to give the highest possible cooling performance. WHEN REPLACING PADS DO NOT USE ALTERNATIVES. The manufacturer is not responsible for the performance, damage to, or safety of the air cooler when alternative pads are used. Using poor quality or incorrect pads may cause water carry-over that might enter electrical components creating an electric shock or fire hazard.** If the pads are re-used they can be easily cleaned by hosing them with clean water, but do not use excess pressure because you might create holes in the pad media.

- Replace the Bleed-off fitting. (This should have been removed at the end of last season. Ref. End Season Maintenance).
- Reconnect the water supply line and turn on the water supply.
- Check the float valve for correct operation and check water level.
- Inspect and clean the pump filter and impellor housing.
(To remove pump from filter)
Press release button on filter, twist the pump body with button depressed, lift pump body out of filter base.
- Check belt tension and adjust if necessary.
- The main blower shaft bearings are sealed for life and do NOT require oiling or greasing.
- Turn on the cooler isolating switch.
- Put the pad frames back on the cooler.
- Restore main power supply and run cooler according to the previous instructions under "Operation of Cooler".

In-season Maintenance

- Turn off the power supply to the cooler.
- Remove pad frames
- Turn off the isolating switch inside the cooler.
- Inspect the pads and clean or replace as required (see previous instructions under "Pre-season Maintenance").
- Check water level and adjust if necessary.
- Turn on the cooler isolating switch.
- Put the pad frames back on the cooler.
- Restore main power supply and run cooler according to the previous instructions under "Operation of Cooler".

End-season Maintenance

- Turn off the power supply to the cooler.
- Remove pad frames
- Turn off the isolating switch inside the cooler.
- Remove pad frames. Clean them by hosing them with clean water, but do not use excess pressure because you might create holes in the pad media.
- Remove and clean the special water "spreader" plates located under each edge of the top panel. Do not disconnect from water hose. When replacing them, check underneath to see that the spreaders are correctly located in the notches under the top panel.
- Drain all the water from the cooler by removing the bleed tray. Do NOT put it back until next season. Do not lose the O-ring seal.
- Disconnect the water supply pipe from the pan. Make sure no water is left in the float valve. Leave pipe disconnected and draining for winter to prevent freezing and splitting.
- Clean the bottom pan thoroughly.
- Replace pad frames.
- Cover the cooler for winter if

Installation Troubleshooting

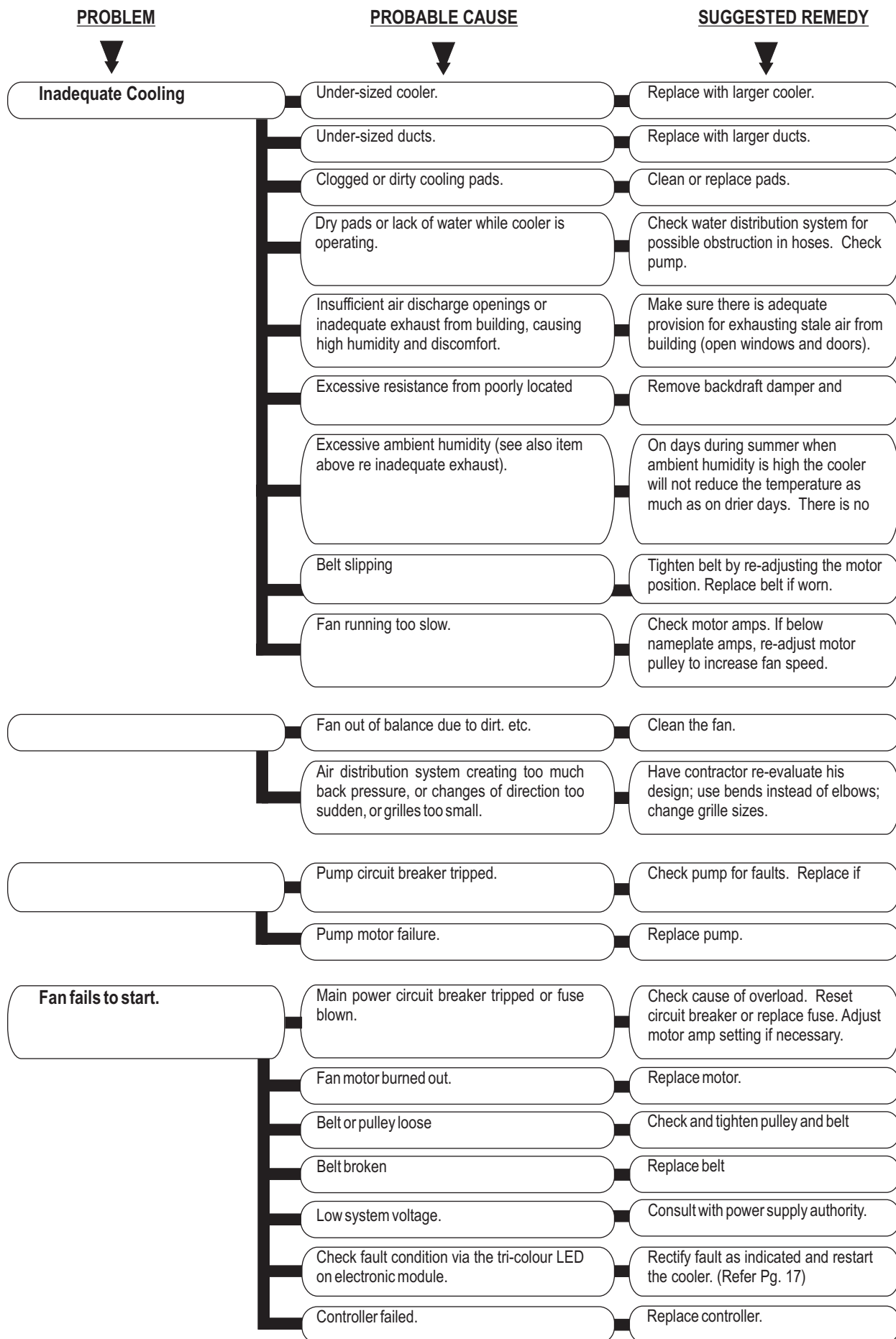

Installation Troubleshooting

<u>PROBLEM</u>	<u>PROBABLE CAUSE</u>	<u>SUGGESTED REMEDY</u>
Pump runs but no water circulation. Pump runs but pads lack water.	Insufficient water in pan.	Adjust float level.
	Water hoses blocked.	Check and clean out blockage.
	Pump strainer blocked.	Clean pump strainer.
Continuous overflow of water.	Float valve adjustment not correct.	Adjust float valve.
	Heavy pad deposits.	Clean or replace pads.
	Auto Drain Valve malfunctioning	Check and remedy function.
Water being blown into the building.		Tighten all connections.
	Water hose broken.	
	Cover not fitted on float valve.	Install correct cover on float valve to
	Pads not fitted correctly into pad frames.	Make sure pads properly installed.
	Water level too low, causing pump to create fountain that is being sucked	Increase water level.
	Incorrect or damaged pads fitted.	Replace with manufacturer's recommended pads.
Unpleasant odour.	New cooler pads.	Drain pan, refill, run pump for a while.
	Algae in pan water.	Drain pan, clean thoroughly with strong cleansing agent, refill, change pads.
	Cooler located near source of unpleasant odour.	Remove source of odour or relocate
	Pads remain wet after shut down.	Run fan on "vent" for 10 minutes after cooling cycle to dry pads out.
	Heavy pad deposits.	Clean or replace pads.
Belt slipping or wearing excessively.	Belt loose.	Tighten belt.
	Pulleys out of line.	Align pulleys.
	Worn belt.	Replace belt.
	Worn or warped pulleys.	Replace and re-align pulleys.
	Moisture on belt.	Stop any water leaks.

Installation Checklist

Owners Name: _____

Telephone: _____

Address: _____

Dealer: _____

Installer: _____

Date Installed: _____

Model No.: _____

Serial No.: _____

Motor Type: _____

Motor Power: _____

- Cooler level and secure.
- All roof work properly sealed.
- Ductwork and air distribution checked and outlets correctly set.
- All wiring complete.
- Control switch correctly installed.
- Motor and pump correctly plugged into sockets.
- Drain/overflow fitting correctly installed.
- Water level and float adjustment checked.
- Pump runs and water evenly distributed to all cooling pads.
- All control functions checked.
- Owner instructed on correct operating procedure and supplied with operating instructions.

Signed by Installer:
Dated:

SERVICE ENQUIRIES:
Contact your local Dealer or Installer for
assistance.

Exploded View

BREEZAIR EXT EVAPORATIVE COOLER

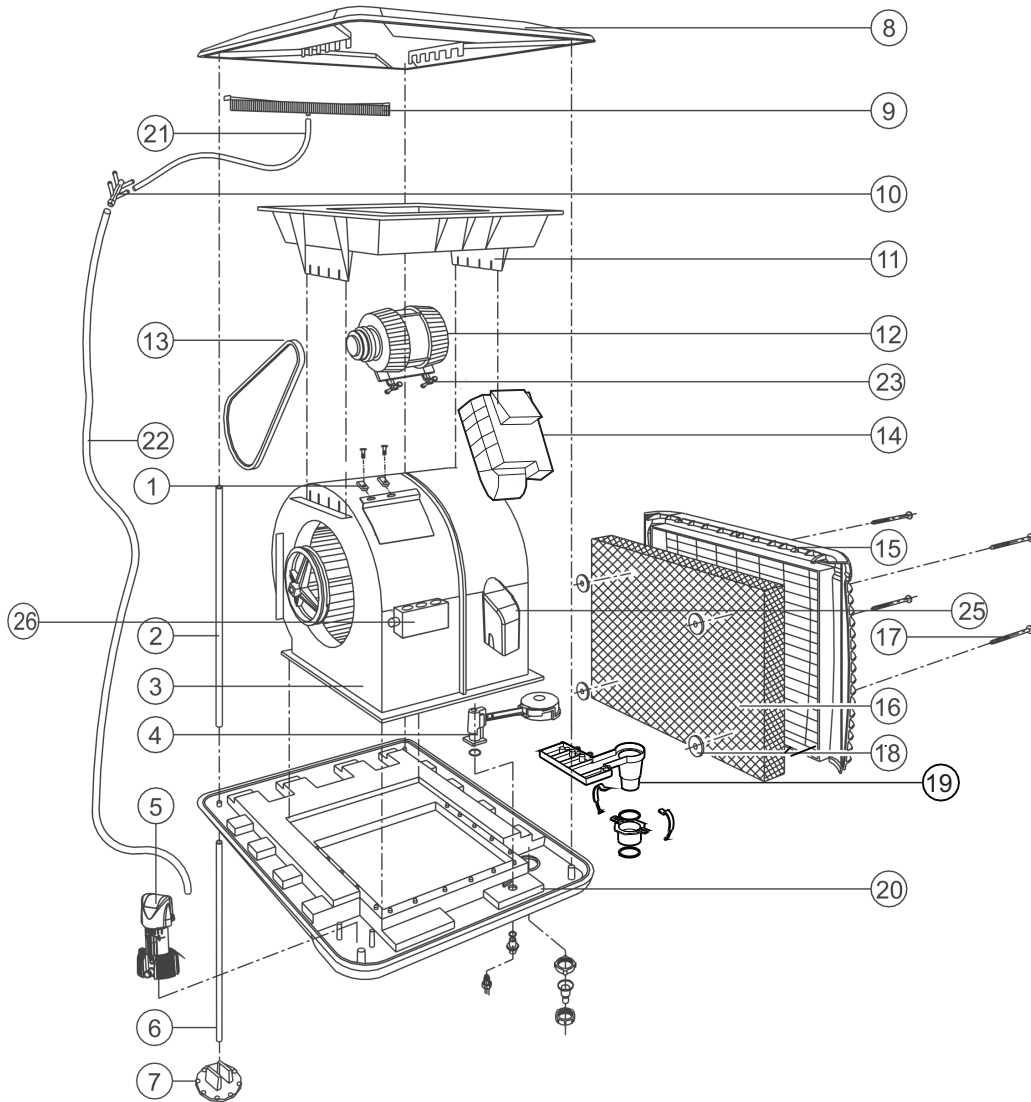

ITEM	DESCRIPTION	QTY	ITEM	DESCRIPTION	QTY
1	J-NUTS & SPEED NUTS	2	13	V-BELT	1
2	POST, CORNER	4	14	JUNCTION BOX	1
3	SCROLL (Blower Housing)	1	15	PAD FRAME	4
4	FLOAT VALVE	1	16	CHILLCEL COOLING PAD	4
5	PUMP - Water Circulation	1	17	PAD RETAINING PIN	8 or 16
6	SUPPORT - Leg Extension	4	18	PAD RETAINING WASHER	8 or 16
7	SUPPORT - Leg Foot	4	19	BLEED FUNNEL ASSEMBLY	1
8	LID	1	20	PAN (Tank)	1
9	SPREADER - Water Distribution	4	21	HOSE 1/2" ID, PVC - Water Distribution	
10	4-WAY DISTRIBUTOR (Water)	1	22	HOSE 3/4" ID, PVC - Water Distribution	
11	BRIDGE	1	23	BELT ADJUSTING ASSEMBLY	1
12	PULLEY, MOTOR - Adjustable	1			



Seeley International (Americas)

Phone: 602-353-8066

Fax: 602-353-8070

Toll Free: 1-800-926-6824

www.convaircooler.com

It is the policy of Seeley International to introduce continual product improvement.
Accordingly, specifications are subject to change without notice.

Breezeair[®]
seeleyinternational.com