

The new TBQI series optimizes superior cooling performance with unmatched product quality, design and value **offering the highest energy efficiency in evaporative cooling**<sup>^</sup>



Introducing the advanced  
**MAGI@TOUCH**<sup>™</sup>  
Next generation smart controller

# THE BREEZAIR TBQI SERIES: NEXT GENERATION UNRIVALLED COOLING CAPACITY

At Seeley International, we have invested more than 40+ years designing and developing superior cooling systems. Known as a trusted leader in the industry, Seeley International is committed to product innovation. Our state-of-the-art NATA Accredited Meridian Test Laboratory allows us to conduct extensive in-house performance testing.

## NEW: 2021 TBQI PRODUCT SERIES!

TBQI is the ideal unit for residential applications and offers premium advanced technology and a revolutionary design for the entire home. With the Breezair TBQI, you will experience outstanding comfort and remarkable energy efficiency.

- Air volume [CFM] meets industry standard rating.
- Best cabinet warranty in the world; no other manufacturer compares to our 25-year guarantee.
- Trusted by homeowners and contractor friendly to install.

## BREAKTHROUGH BLACK OPAL™ MINI-CELL^ CHILLCEL® PAD TECHNOLOGY

- The only evaporative cooling medium of its kind. Fully manufactured in Australia to address the harsh global climate. It's an **absolute out-performer!**
- Exclusive small cell design provides cutting-edge cooling capacity.
- Maintains our global leading Mini-Cell^ Chillcel® pad technology, which increases surface area of the pads by 25%, dramatically multiplying cooling capacity and efficiency - **BEYOND BELIEF!**
- **BLACK OPAL™ MINI-CELL^ CHILLCEL® pads** deliver transformational aesthetics to your home enabling the unit to blend seamlessly into its surroundings.

## HIGHLY DURABLE AND NON-CORROSIVE CABINET AND WATER RESERVOIR

High performance Permatuf® polymer construction will not corrode or rust.

## EXCEPTIONAL WATER DISTRIBUTION INCREASES COOLING EFFECT

This Australian designed, world patented, free flow, water distributor ensures constant, even pad saturation increasing the cooling effect and outperforming competitor products.

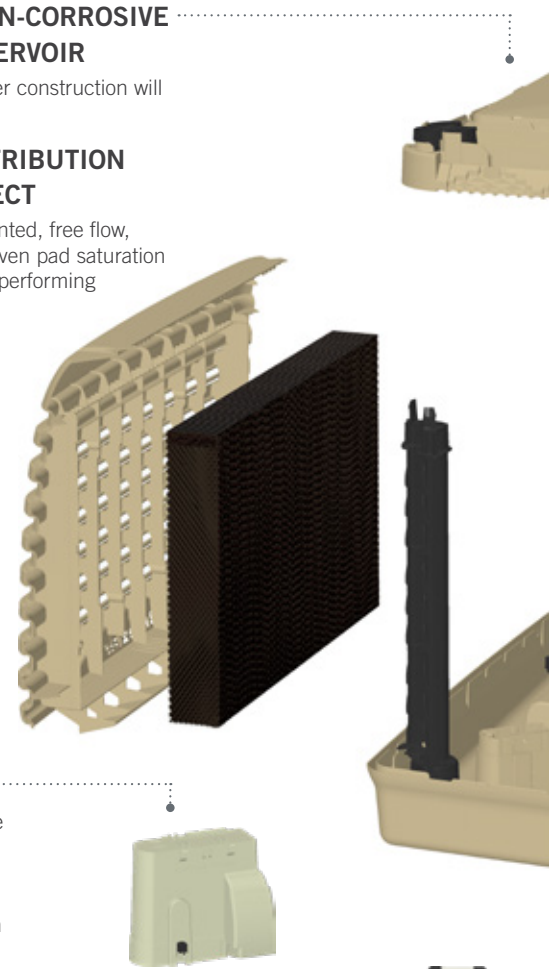

## DIGITAL SMARTBOX™

The Smartbox™ digital control module monitors and controls all of the cooler's features to provide ultimate comfort conditions, temperature sensing and water quality supervision – completely, safely and reliably.

## TORNADO® PUMP

- Exceptional reliability in extreme conditions
- Dual directional impact start motor/impeller
- Encapsulated motor with overload cut-out, stainless steel shafts and bearings are fully protected from water

## MAGIQTOUCH® TOUCH SCREEN TECHNOLOGY

Smart, sophisticated and incredibly intuitive, your MagIQtouch® controller makes operating your Breezair, a breeze. Control the temperature, fan speed and many more features on a user friendly touch screen. Discreet and modern design will blend seamlessly into the décor of your home.



**MAGIQTOUCH®**  
wired controller

Touch screen, wall mounted controller wired to your home or building



**MAGIQTOUCH®**  
wireless controller  
(Radio Frequency)

Use the latest in Radio Frequency (RF) channel hopping technology with no need for wiring



^Based on published research articles, NATA Laboratory test results and publicly sourced data.



## BREEZAIR GUARANTEE

For complete peace of mind, Breezair backs every one of its air conditioning systems with an industry leading comprehensive guarantee program.

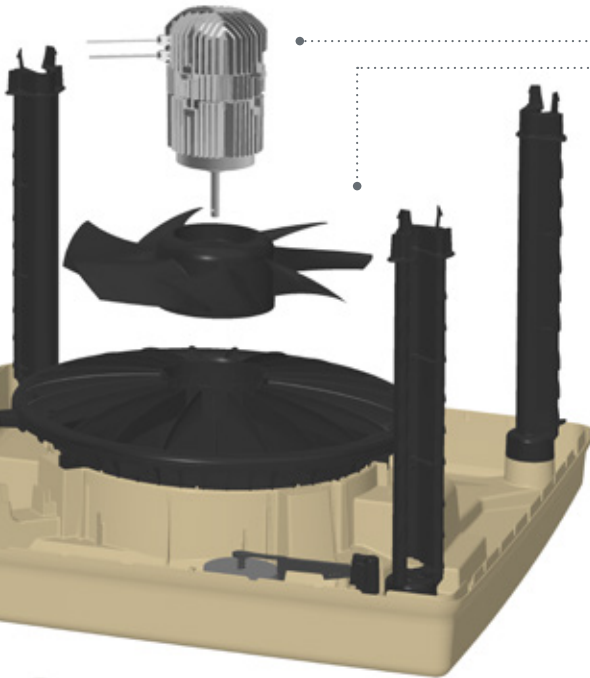
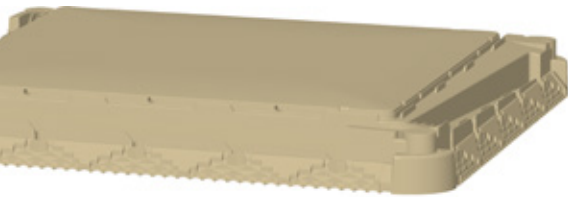

### INVERTAIR™ INVERTER MOTOR

- Ensures long term performance and incredible reliability of your system
- Variable speed motor offers maximum control over comfort level
- Energy efficient - consumes less energy than conventional motors

### SUPERSTEALTH® FAN

SuperStealth® axial fan is specifically designed for aerodynamic, efficient and reliable air delivery

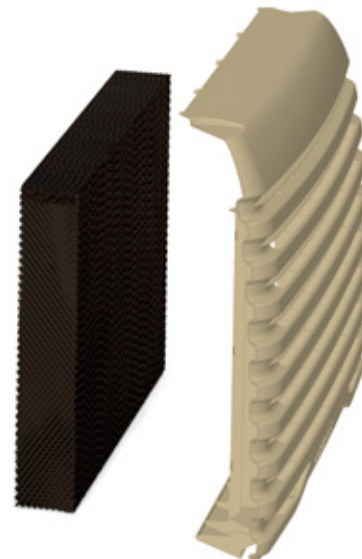

### WATERMANAGER™ SAVES WATER

- Uses the minimum amount of water to achieve high efficiency cooling
- Water quality monitoring to maximise water savings



### AUTO WATER DRAINING KEEPS YOUR SYSTEM CLEAN

- Empties the reservoir automatically when system is not in use, leaving it clean and dry
- Ensures the system is operating at maximum efficiency, while using the minimum amount of water
- Helps to avoid the seasonal maintenance\* as required by some other similar products

\*Seasonal maintenance does not replace regular maintenance of the unit as required for peak performance.

## OPTIONAL EXTRAS MAGIQTOUCH® AIR SENSORS & AUTO WEATHERSEAL



### Internal Air Sensor

A remote temperature and humidity sensing module.

Enables the MagiQtouch® Controller to be mounted in a convenient location (e.g. control room or living area), while still sensing air from the conditioned space.

### External Air Sensor

Intuitively optimises water and energy usage based on outside ambient conditions and displays current outside temperature.

Sensing module automatically drains the water tank when temperature nears freezing.



### AUTO WEATHERSEAL

The AUTOWeatherseal closes the cooler air discharge outlet automatically, thus significantly reducing natural air currents from circulating in and out of the building. The result – a more comfortable and controlled environment.

*\* Requires a 21 5/8" square raw edged roof jack. Refer to technical specifications for more information. Be sure to talk to your installer about optional extras. Units will not operate with a Breezair roof jack adapter.*

# Technical Information

Specification		TBQI 5500	TBQI 7500
<b>Airflow</b>	Industry standard (cfm)	5,500	7,500
<b>Cooling capacity*</b>	BTU/hr	25,930	34,460
<b>Power consumption (total)</b>	Watts max	510	680
	Current rated (amp)	5.5	7.0
<b>Power supply</b>	Voltage / Phases / Hz	115 / 1 / 60	115 / 1 / 60
<b>Controller</b>	Type	Digital	Digital
<b>Fan</b>	Type	Axial	Axial
	Diameter (mm)	21.1	21.1
<b>Motor</b>	Type	Inverter	Inverter
	Speed max (rpm)	1,150 VAR	1,300 VAR
	Output Max (Watts)	300	380
	Current Max (amp)	4.0	5.0
	Overload	One Shot Fuse	One Shot Fuse
<b>Pump</b>	Type	Centrifugal	Centrifugal
	Motor	Synchronous	Synchronous
	Power - Rated (amp)	0.7	0.7
	Flow rate (gal/min)	5.5	5.5
	Voltage / Phases / Hz	115 / 1 / 60	115 / 1 / 60
<b>Cooling pad Chillcel</b>	Overload	Thermal One Shot Fuse	Thermal One Shot Fuse
	Enclosure rating	IPX4	IPX4
<b>Water</b>	Size (inches)	33½ x 14¾ x 3½ (4 Pads)	33½ x 20¾ x 4¾ (4 Pads)
	Pad area (ft2)	13.8	19.2
<b>Shipping</b>	Tank capacity (gal)	6.1	6.1
	Inlet (inches)	½" male BSP	1/2" male BSP
	Drain (mm/inches) Configurable to local requirements	1½ " male BSP	1 1/2 " male BSP
	Dimensions incl. pallet (inches)	45¼ x 45¼ x 29½	45¼ x 45¼ x 35½
<b>Connecting duct</b>	Volume (ft3)	35	42.4
	Mass (lbs)	148	155
	Operating (lbs)	199	205
	Length x width (inches)	21 5/8 x 21 5/8 or 17 3/4 x 17 3/4 Adaptor	21 5/8 x 21 5/8 or 19 3/4 x 19 3/4 Adaptor

\*This cooler has been tested in accordance with the requirements of the California Energy Commission Appliance Efficiency Regulations, Section 1603 and 1604.

FAN CURVE (CFM)

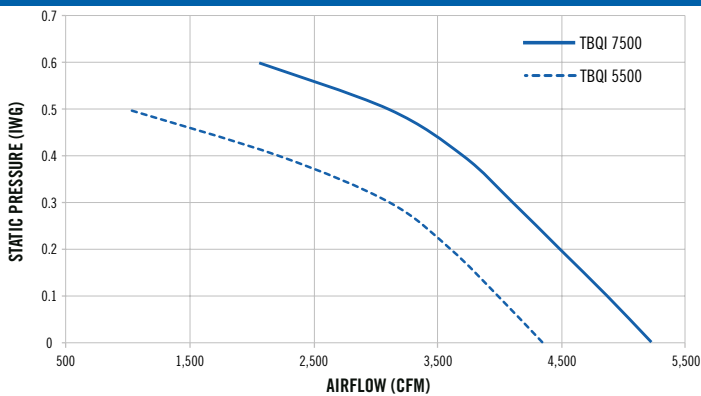

Model#	Industry STD Rating CFM	Motor H.P.	Certified Air Delivery (CFM) VS. Inch Water Gauge (IWG)						
			0.0	0.1	0.2	0.3	0.4	0.5	0.6
TBQI 5500	5,500	0.4	4,340	3,980	3,600	3,110	2,220	1,000	-
TBQI 7500	7,500	0.5	5,230	4,870	4,490	4,110	3,710	3,110	2,060

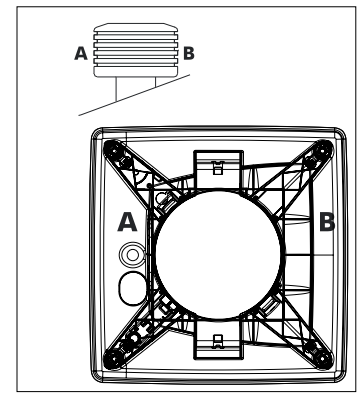
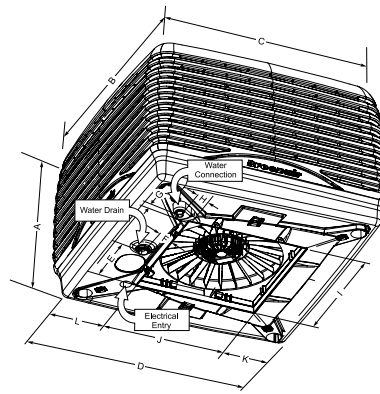

CABINET DETAILS

Model#	A	B	C	D	E	F	G	H	I	J	K
TBQI 5500	27	45 ¼	45 ¼	42 ½	10 ¾	3 ¾	3 ¼	3 ¼	21 7/8	21 7/8	9 ¾
TBQI 7500	33	45 ¼	45 ¼	42 ½	10 ¾	3 ¾	3 ¼	3 ¼	21 7/8	21 7/8	9 ¾

Note: All dimensions are in inches.

## Typical installation

<b>Drain outlet</b>	1 ½" BSP to ¾" OD Reducer piece designed for push-on use with a flexible hose (3/4" ID) or solid PVC pipe (3/4" ID)
<b>Water inlet</b>	½" BSP to 3/8" Nom or ½" BSP to ¼" compression adapter pieces
<b>Electrical</b>	½" Flexible conduit
<b>Pack Out Kit</b>	The kit consists of 65' 6 pin cable, auto drain valve and plumbing fittings (supplied as standard inside cooler).
<b>Wall Control Kit Options (Required)</b>	<b>Option 1:</b> MagIQtouch Wall Control KIT - WIRED Part #094298 <b>Option 2:</b> MagIQtouch Wall Control KIT - RF WIRELESS Part #118376

## Cooler Discharge Air Temperature Chart

Ambient Dry Bulb Temperature °F	Ambient Relative Humidity %								
	10	20	30	40	50	60	70	80	90
50	36.6	38.3	39.9	41.5	43.0	44.5	45.9	47.3	48.7
60	43.3	45.5	47.6	49.6	51.5	53.3	55.1	56.8	58.4
70	49.8	52.6	55.2	57.6	59.9	62.1	64.2	66.3	68.2
80	56.0	59.5	62.7	65.6	68.4	71.0	73.4	75.7	77.9
90	62.1	66.3	70.1	73.6	76.9	79.9	82.6	85.2	87.7
100	68.0	73.1	77.6	81.7	85.4	88.8	91.9	94.8	N/A
110	73.9	79.9	85.2	89.8	94.0	N/A	N/A	N/A	N/A
120	79.7	86.8	92.8	98.0	102.6	N/A	N/A	N/A	N/A
130	85.5	93.7	100.5	106.3	N/A	N/A	N/A	N/A	N/A

This chart represents approximate air temperatures based on 87% saturation efficiency at sea level. From tests carried out to Australian Standard 2913.

## Sizing Instructions

Use the Certified Air Delivery performance tables and the following procedure to properly size a Seeley International evaporative cooling unit for your application.

The performance or Cooling Capacity of an evaporative cooler is a function of both the air flow (CFM) and air discharge temperature.

Static pressure, or duct system resistance, also impacts on air delivery and should be considered to correctly size the cooling unit.

### 1. Determine design Conditions

Outside Dry-Bulb (DB)  
Outside Wet-Bulb (WB)  
Inside Dry-Bulb (TI)

### 4. Determine the CFM required

$CFM = 0.925 \times \text{Sensible Heat Load} / (TI - LAT)$

### 2. Determine the design Sensible Heat Load (Btu/h)

### 5. Determine the cooler(s) required by referring to the air flow charts above.

### 3. Determine the Cooler Leaving Air Temperature (LAT)

$LAT = DB - [(DB - WB) \times EFF]$   
where  $EFF = 0.87$  for Chillcel media



www.seeleyinternational.com



Seeley International Americas  
1002 S 56th Avenue, Suite #101 Phoenix AZ 85043 | Ph:602 353 8066  
4430 Glencoe Street, Denver CO 80216 | Ph:303 375 0878

Email: ussales@seeleyinternational.com

Information in this brochure was correct at the time of preparation. E & OE

