

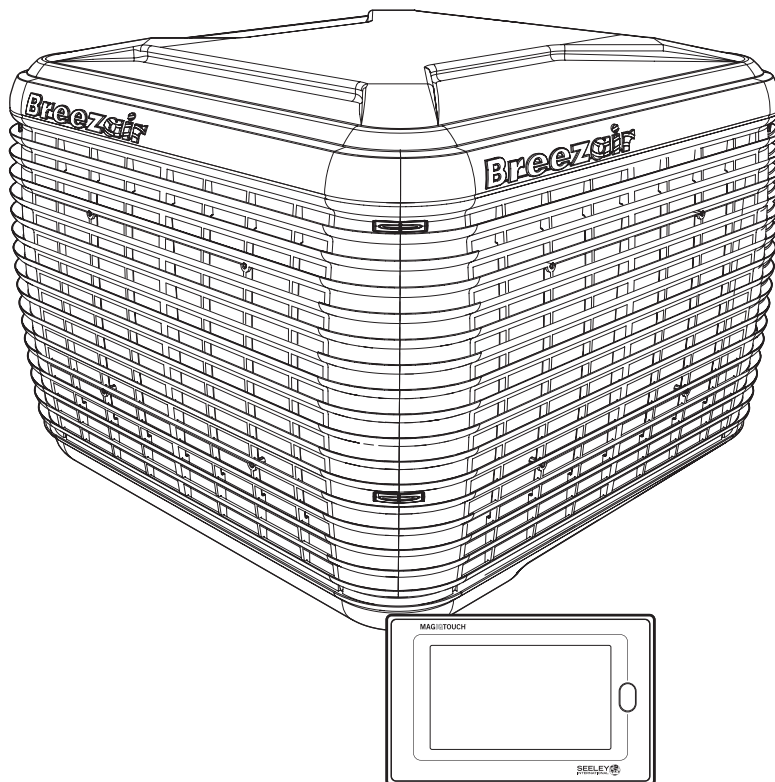

INSTALLATION MANUAL

EXQ Evaporative Coolers



(English)

Original English Instructions

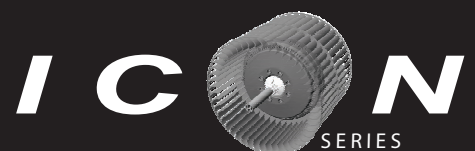

TABLE OF CONTENTS

IMPORTANT SAFETY INSTRUCTIONS

Warnings	1
Employer and Employee Responsibilities	1
Installer and Maintenance Contractors - Risk Assessment	1
Some Points to Consider	1
Other Important Requirements	1

QUICK GUIDE

2

INSTALLATION

Pack Out Kit Contents	4
Cooler Location	4
Access for Servicing and Maintenance	4
Installing the Roof Jack	5
Conveying the Cooler to the Roof	5
Mounting the Cooler	5
Securing the Leg Supports	6
Weatherseal and Latch	6
Electrical Requirements	7
Installing the Mains Power Cable	7
Installing the Controller Cable	7
Water Requirements	8
Water Connections	8
Coolers with Drain Valves	8
Installing the Inlet Solenoid	8
Fitting the Solenoid Cover	9
Installing the Drain Valve	9
Drain Valve Assembly	9

CONNECTING THE MAGIQTOUCH CONTROLLER

9

COMMISSIONING

Diagnostic LED	10
Salinity LED	10
MagIQtouch Controller Information	10
Fault Codes	11
Testing the Direct Drive Motor	11
Setting the Water Level	12
Testing the Drain Valve	12
Testing the Pump	12
Refitting the Pad Frames	12
Adjusting Cooler Settings	13
Commissioning Completion Checklist	14

TROUBLE SHOOTING

15

NOTES

16

WARNING! Failure to install and commission the product in compliance with these instructions, or failure to do the job properly and competently, may void the customer's warranty. Further, it could expose the Installer and/or the Retailer to serious liability.

IMPORTANT SAFETY INSTRUCTIONS

READ AND SAVE THESE INSTRUCTIONS FOR FUTURE REFERENCE.

Means for all pole disconnection must be incorporated in the fixed wiring in accordance with the wiring rules.

If the supply cord is damaged, it must be replaced by the manufacturer, its service agent or similarly qualified persons in order to avoid a hazard.

The following specifications for the cooler water supply are required:

Min Water Pressure: 15psi (100kPa)

Max Water Pressure: 115psi (800kPa)

New hose sets supplied with the appliance are to be used and old hose-sets should not be re-used.

WARNINGS

TO REDUCE THE RISK OF FIRE, ELECTRIC SHOCK, OR INJURY TO PERSONS, OBSERVE THE FOLLOWING:

1. Installation work and electrical wiring must be done by qualified person(s) in accordance with all applicable codes and standards, including fire-rated construction.
2. When cutting or drilling into wall or ceiling, do not damage electrical wiring and other hidden utilities.
3. Ducted fans must always be vented to the outdoors.
4. Do not use this fan with any solid-state speed control device.

EMPLOYER AND EMPLOYEE RESPONSIBILITIES

The installation and maintenance of evaporative coolers at height has the potential to create Occupational Health and Safety issues for those involved. Installers are advised to ensure they are familiar with the relevant State and Federal legislation, such as Acts, Regulations, approved Codes of Practice and National Standards, which offer practical guidance on these health and safety issues. Compliance with these regulations will require appropriate work practices, equipment, training and qualifications of workers.

Seeley International provides the following information as a guide to contractors and employees to assist in minimising risk whilst working at height.

INSTALLER AND MAINTENANCE CONTRACTORS - RISK ASSESSMENT

A risk assessment of all hazardous tasks is required under legislation. A risk assessment is an essential element that should be conducted before the commencement of work, to identify and eliminate the risk of falls or to minimise these risks by implementing control measures. There is no need for this to be a complicated process, it just is a matter of looking at the job to be done and considering what action(s) are necessary so the person doing the job does not injure themselves.

This should be considered in terms of:

- What are the chances of an incident happening?
- What could the possible consequence be?
- What can you do to reduce, or better still, completely get rid of the risk?

SOME POINTS TO CONSIDER

- What is the best and safest access to the roof and working areas?
- If a worker is alone, who knows they are there and if they get into difficulty, how can they summon help? (Call someone on the ground? Mobile phone? Etc.)
- What condition is the roof in? Should the trusses, underside or surface be checked?
- Does the worker have appropriate foot wear? (Flat sole jogger type is advisable.)
- Are all power cables / extension leads safe and appropriately rated?
- Are all ladders, tools and equipment suitable in good condition?
- Where ladders are to be used, is there a firm, stable base for them to stand on? Can they be tied or secured in some way at the top? Is the top of the ladder clear of electricity supply cables?
- Is there a roof anchor to attach a harness and lanyard to? If so, instruction should be issued for the use of an approved harness or only suitably trained people used.
- Are all tools and materials being used, prevented from slipping and falling onto a person at ground level? Is the area below the work area suitably protected to prevent persons walking in this area?
- Does the work schedule take into account weather conditions, allowing for work to be suspended in high winds, thunder storms/lightning or other types of weather giving wet, slippery surfaces?
- Is there an on-going safety check system of harnesses, ropes, ladders and access/lifting equipment and where they exist on roofs, anchor points before the commencement of work?
- Is there a system which prevents employees from working on roofs if they are unwell or under the influence of drugs or alcohol?
- Are there any special conditions to consider i.e. excessive roof pitch, limited ground area, fragile roof, electrical power lines?

OTHER IMPORTANT REQUIREMENTS

- Never force parts to fit because all parts are designed to fit together easily without undue force.
- Never drill holes in the pan (Reservoir) of the cooler.
- Check the proposed cooler location, to ensure that it is structurally capable of supporting the weight of the cooler, or provide an adequate alternate load bearing structure.

Ensure the installation complies with all local and national regulations with regards to electrical, plumbing and bushfire/wildfire construction requirements.

QUICK GUIDE

STEP 1

SAFETY

Read & understand the safety section.

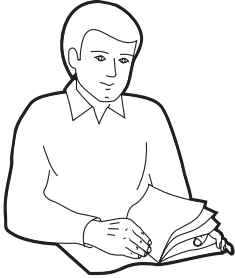

page 1i

STEP 2

COOLER LOCATION

Check cooler location. Consider regulations. Discuss with customer.

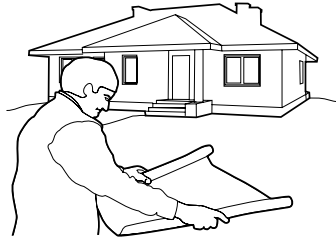

page 4

STEP 3

INSTALL ROOFJACK

Install 24G metal roof jack and seal before mounting.

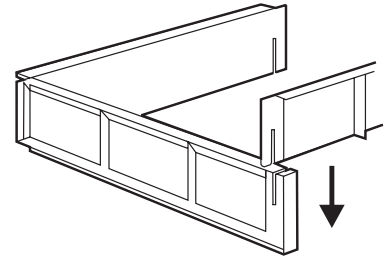

page 5

STEP 7

POWER CABLE

Use the main power termination box for wiring connections inside cooler. Terminate power cable outside of cooler in a junction box.

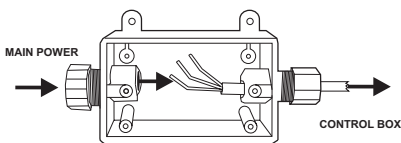

page 7

STEP 8

WEATHERSEAL

Check operation of the Weatherseal

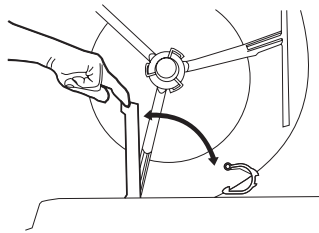

page 6

STEP 9

CONTROLLER CABLE

Connect one end of the controller cable to cooler electronics then feed the other into dropper.

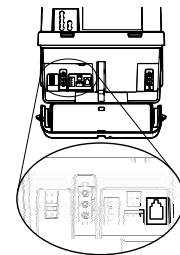

page 7

STEP 13

CONNECTING THE CONTROLLER



page 9

STEP 14

COMMISSION THE COOLER

Test the cooler with the MagIQtouch Controller. Check diagnostics of cooler electronics. Test the Direct Drive motor.

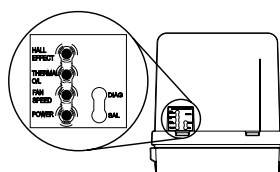

page 10

STEP 15

SETTING THE CONTROL METHOD

Set water management method
Set salinity control method.



page 13

STEP 19

COOLER SETTINGS

Where necessary, adjust the cooler settings to suit customer requirements using the controller.

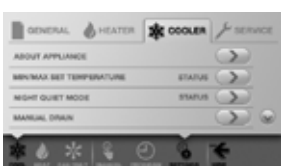

page 13

STEP 20

FINAL CHECK

Test & complete the commissioning checklist at the end of this document.



page 14

STEP 21

CLEAN UP

Clean up the site!



page 14

QUICK GUIDE

STEP 4

LEVEL ROOF JACK

Position, level, secure and seal the roof jack.

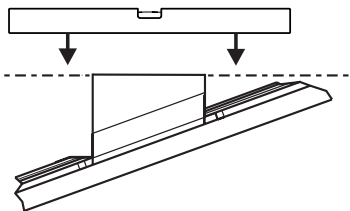

page 5

STEP 5

CONVEY COOLER

Convey the cooler to the roof.

Note! Always use 2 people when handling manually.

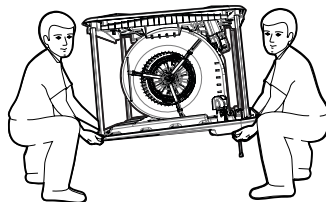

page 5

STEP 6

MOUNT COOLER

Mount cooler to the dropper. Check pan (reservoir) is level.

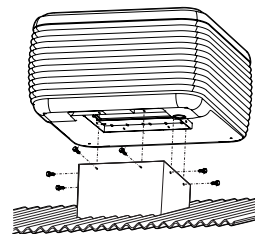

page 5

STEP 10

REGULATIONS

Read & adhere to the local & national electrical and plumbing regulations.

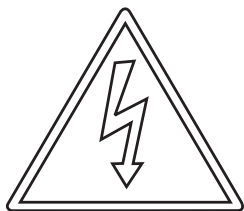

page 7

STEP 11

INLET SOLENOID

Fit the solenoid.

Connect the cable.

Connect the water supply.

Install the drain pipe.

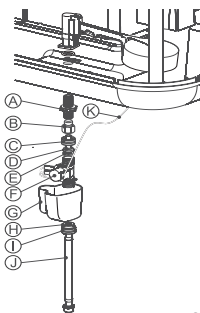

page 8

STEP 12

DRAIN VALVE

Fit the drain valve.

Connect the discharge system. Connect the cable to the cooler electronics.

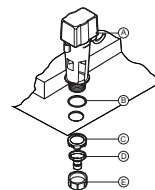

page 9

STEP 16

WATER LEVEL & DRAIN

Set the water level.

Test the drain valve.

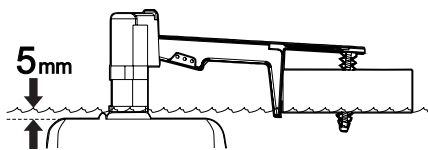

page 12

STEP 17

REFIT PAD FRAMES

Refit the pad frames before testing the pump.

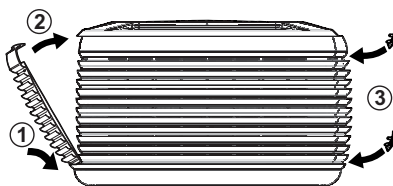

page 12

STEP 18

TEST PUMP

Turn on the cooler and check the water is evenly distributed to all pads.



page 12

STEP 22

CUSTOMER HANDOVER

Show customer how to operate the cooler. Give them both the MagiQtouch Controller and cooler owner's manual. Explain maintenance requirements.



page 14

INSTALLATION

PACK OUT KIT CONTENTS

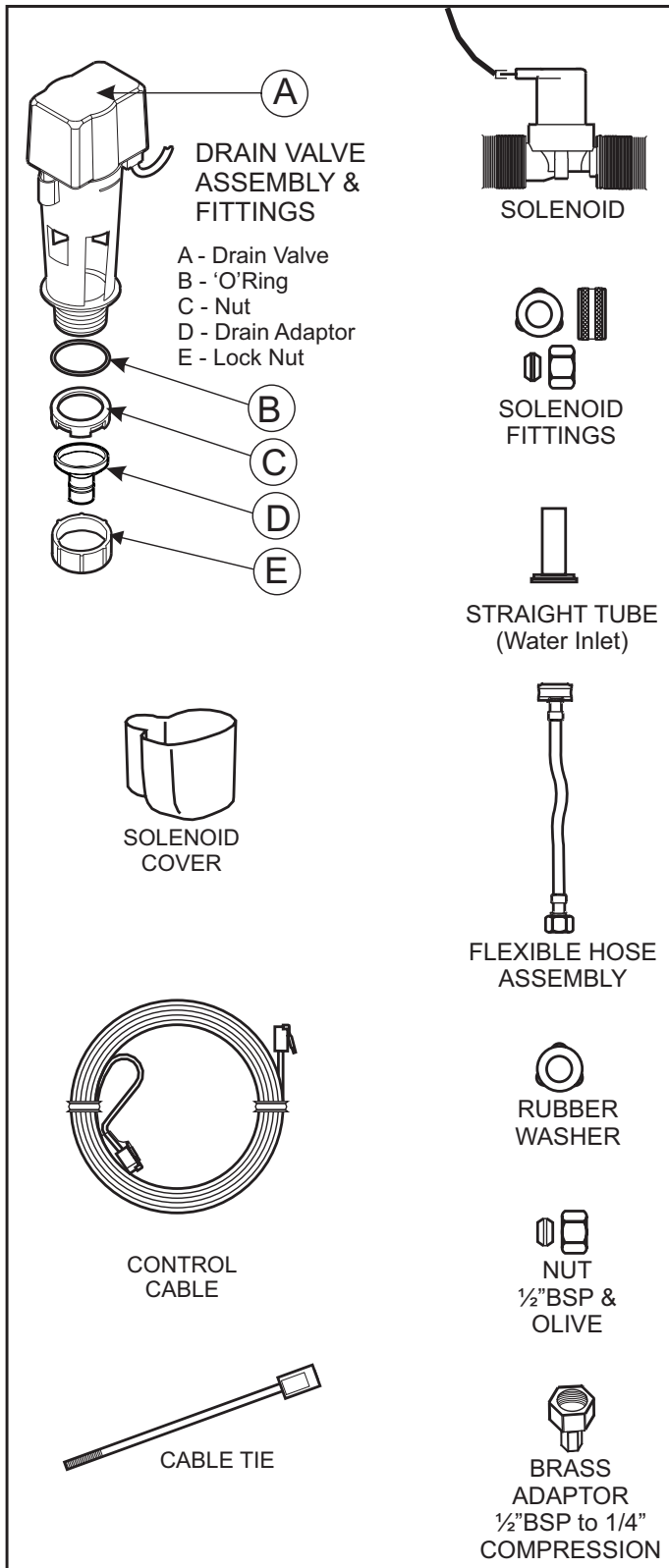

COOLER LOCATION

Check the proposed cooler location to ensure it is structurally capable of supporting the weight of the cooler. If the roof is structurally inadequate, provide an alternate load bearing structure.

The ideal location for the cooler is in a central position on the roof (away from sleeping areas and where people spend most of their time) so that the duct runs are of approximately the same length. Carefully consider neighbouring residences and noise levels when locating the cooler, if necessary talk to the customer and the neighbour before carrying out the installation.

Always locate the cooler where it will receive adequate fresh air and not in a recess where it may be starved for air or where the air is polluted.

Ensure location is a minimum of:

- 10' (3m) from a solid fuel heater flue,
- 5' (1.5m) from a gas flue,
- 17' (5m) from a sewer vent, and
- 2' (600mm) from a wall.

The cooler must be mounted at least 10' (3m), preferably 17' (5m), away from any TV antenna or antenna cables.

EXQ MODELS

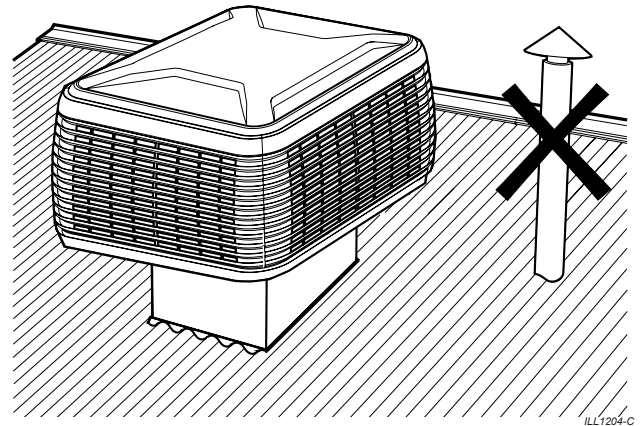

Make sure the cooler is not between the antenna and the transmission tower that is providing the television signal to the home.

Allow adequate access to and around the cooler for maintenance. Provision must be made for access to electricity, water supplies and drains.

Note! Do you need to discuss the installation of items like safety anchor points with the customer?

ACCESS FOR SERVICING AND MAINTENANCE

The cooler should be installed in a position that allows adequate access for installation, and future maintenance and servicing activities. This should comply with installation guidelines and any local, State and National regulations.

Consider the following for installation location:-

- Which has clear access to and around the cooler
- Which is clear of fixtures in line with below clearances
- Which is clear of fall edges (> 10' or 3m away)
- Which is structurally capable of supporting the weight of the cooler and service technicians

Required clearances around the cooler for future maintenance and servicing are shown adjacent.

INSTALLATION

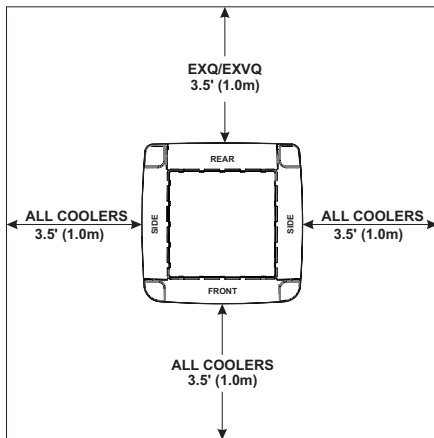

ILL2645-B

Extra service or warranty charges may apply for the cost of any equipment or additional labour involved in accessing the cooler if these guidelines are not met.

INSTALLING THE ROOF JACK

New Installation

Use 24G or stronger metal roof jack. The cooler may then be attached directly to the jack.

Replacement Installation

Roof Jack recommended wall thickness should be 24G or stronger. The supplied roof jack adaptor may be required to attach the cooler to the existing roof jack.

To assemble the roof jack adaptor, hold panels at 90 degrees to one another. Align slots in upper and lower panels then slide together.

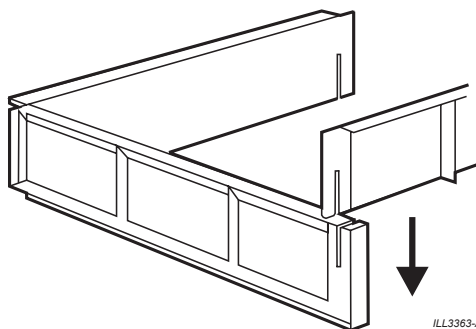

ILL3363-A

Note! It is recommended that a strip of foam or sealant is applied to the upper flange on the roof jack before securing the cooler to provide an airtight seal.

Ensure that the top of the roof jack is level and square in all directions (use a spirit level). This helps with levelling the cooler.

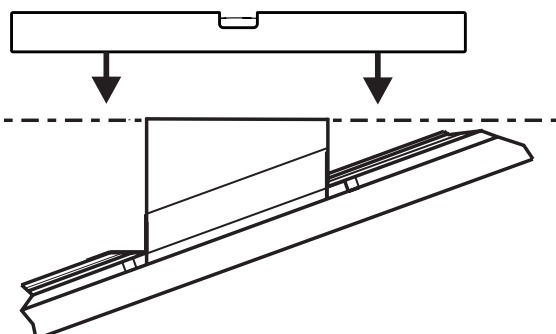

ILL922-B

CONVEYING THE COOLER TO THE ROOF

Lifting and installing the cooler is made easier by removing the pad frames first. They can be replaced at the very end of the installation procedure.

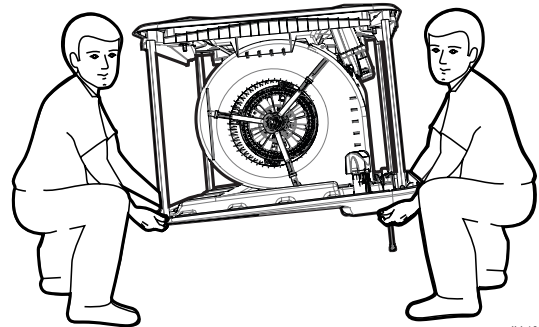

ILL1667-A

Do not slide the cooler, lift and carry it. It is recommended that at least 2 people carry the cooler whenever it needs to be moved. Do not drop the cooler. Always handle with care.

Important! For lifting or pulling purposes when using ropes or slings, always apply the ropes around fan housing. Never tie them to any or all of the 4 round corner posts.

WARNING! Take care that the ends of ladders, etc. don't penetrate into the opening of the cooler, as the Weatherseal or the cut-off plate may be damaged.

CAUTION! Never try to raise the cooler to the roof alone.

MOUNTING THE COOLER

Locate the cooler on the dropper with the pan (reservoir) sump on the low (gutter) side of the installation.

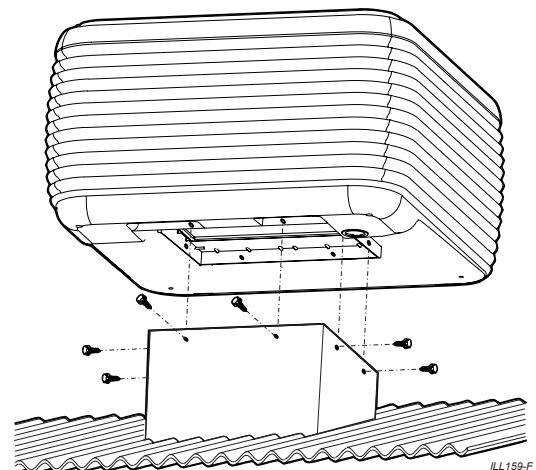

ILL159-F

Fix the cooler to the dropper with 8 self-tapping screws provided (2 screws per side). There are ten screw locations identified by "V" notches. If access to the "high roof side" is limited, use 3 screws on each side and 2 on the front. In exposed or high wind areas, seek advice from a structural engineer.

Important! Screw length must be less than 1.5" (40mm) to avoid interfering with the weatherseal.

INSTALLATION

SECURING THE LEG SUPPORTS

The telescopic leg supports (with feet attached) slide up and down inside the four corner posts. By removing the screw from the lower end of the corner post you enable the leg support to slide down to roof level.

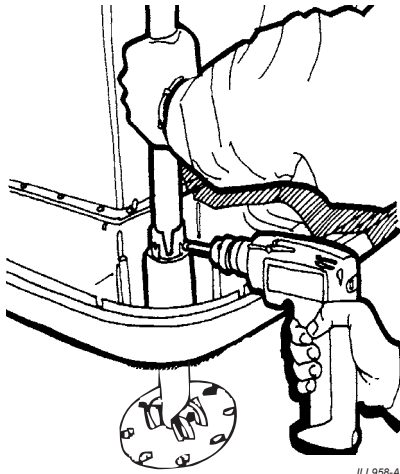

Make sure each leg is vertical before securing. Secure foot to roof with 2 screws (minimum).

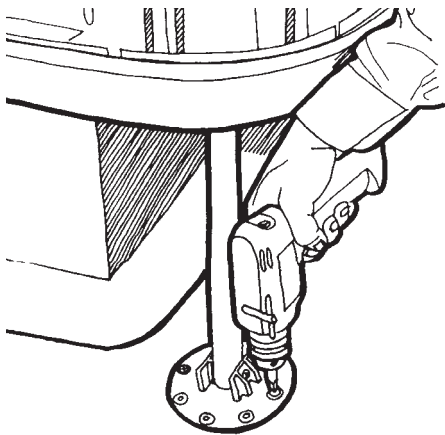

Maintain downward pressure on corner post as you replace the screw to ensure that the bottom of the corner post is sitting flush with base of corner support (view through "V" notch). Ensure screw is horizontal when replaced.

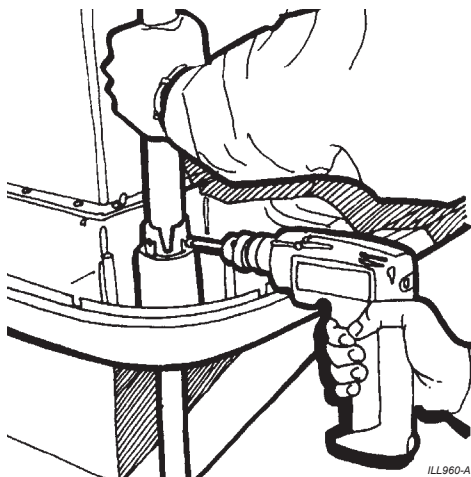

The support legs are not full weight bearing and are only intended for additional support in case of high winds, etc.

WEATHERSEAL AND LATCH

(Model dependant, refer to Dealer.)

Where fitted, the Weatherseal latch performs two functions. In the locked position it acts as a latch, preventing movement during transport.

LOCKED POSITION

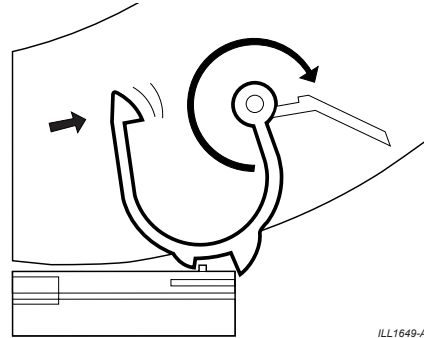

OPERATING POSITION

In the operating position it acts as a restrainer, preventing gusts of wind from opening the Weatherseal. Once the cooler is installed on the roof, squeeze the latch and rotate it clockwise to its operating position.

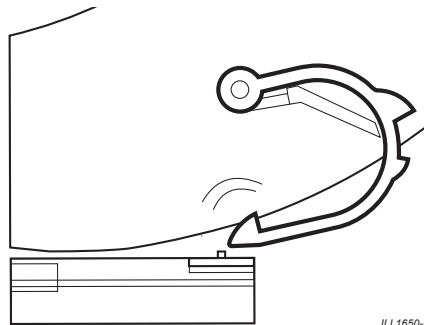

Check the Weatherseal moves freely and without obstruction by lifting the latch and rotating counterweighted arm.

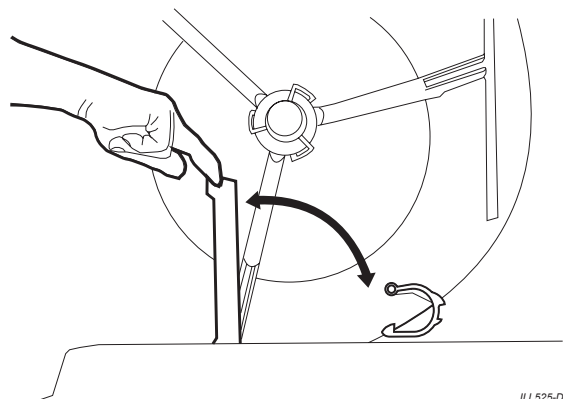

INSTALLATION

ELECTRICAL REQUIREMENTS

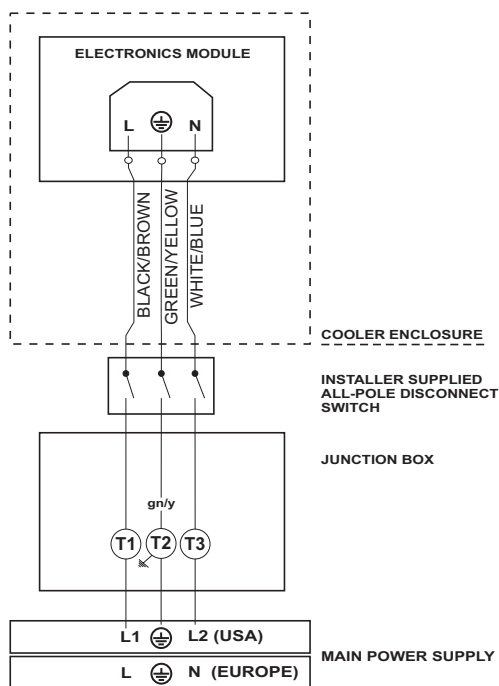

ILL1898-A

Installation of the cooler must conform to local electrical rules, regulations and standards.

Important! It is a requirement of Seeley International that all Breezair coolers be connected to a dedicated circuit to the distribution board, with a separate circuit breaker and incorporate all pole disconnection switch in accordance with the local wiring rules.

Electrical supply specifications may vary depending on model or region. Please refer to the rating label attached to the cooler for details.

WARNING! If the supply cord is damaged, it must be replaced by the manufacturer, its service agent or a similarly qualified person in order to avoid a hazard.

INSTALLING THE MAINS POWER CABLE

This cooler contains an electronics module (control box) with main power supply termination box separated and connected via a cable and plug assembly.

The point of entry into the cabinet of the cooler is by knockouts in the pan (reservoir).

Seal the gap between the conduit and the knock-out hole with silicone sealant after making connections and clamping the conduit cable.

Important! Ensure that all electrical connections are tight. Loose connections will cause overheating that may lead to machine damage or fire.

Replace all covers on completion of work, using only the screws supplied.

Do not tamper with factory wiring. Before leaving the job, a trained, licensed technician must check that the cooler is operating correctly.

The main power termination box is provided to facilitate easy wiring connections. Cable glands are provided for 1/2" ID conduit.

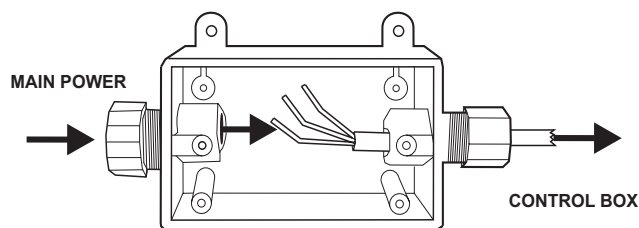

ILL1395-A

Terminate the power cable outside of the cooler in a junction box installed nearby. Refer to the field wiring diagram in the previous section. The fixed wiring must be fitted with an all pole disconnection switch that breaks the active (hot) and neutral (common) in accordance with local wiring rules. It is recommended that the junction box be located and installed on the dropper (roof jack).

IMPORTANT REMINDER!

Do not route extra-low voltage data/communication and low voltage supply mains cables without first consulting your local wiring standards. Routing data/communication cables and supply mains cables in close proximity can present an electrical hazard and can be detrimental to the performance of the product, resulting in intermittent communication errors, locking up of screens, displays dropping out and inconsistent erratic operation.

INSTALLING THE CONTROLLER CABLE

Seeley International recommends:

- Not routing data/communication and supply mains voltage cables in the same conduit.
- Not cable tying or taping data/communication and supply mains voltage cables together.
- A minimum separation distance, as specified by your local wiring standards, between data/communication and supply mains cables. In Australia, this minimum separation distance is 2" (50mm).

Connect one end of the control cable (with ferrite suppressor) to the cooler electronics box.

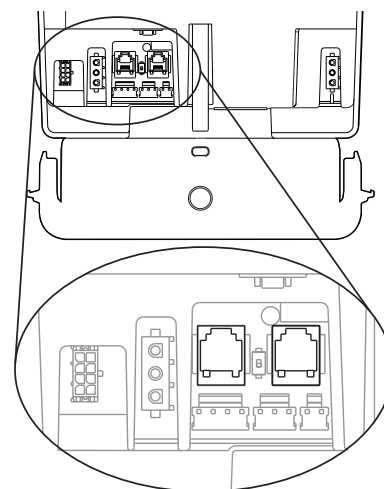

ILL2149-A

Your cooler electronics will have 2 x RJ ports as shown above. For cooler electronics with 2 x RJ ports, the wall control cable can be fitted to either.

INSTALLATION

INSTALLING THE CONTROLLER CABLE

Run the cable to the roof space and then to the controller via the mains power cable entry point and plug in to the rear of the wall control.

Note! The maximum length for the wall control cable to travel alongside the power cable is 33' (10m).

WARNING! Do not let the cable, the cable ends, or the control box get wet. Position the cable in the dropper so they will be accessible from inside the roof space.

WATER REQUIREMENTS

Installation of the cooler water supply must conform to local plumbing rules, regulations and standards.

The following specifications for the cooler water supply are required:

Water Connection	1/2" BSP
Min Water Pressure	15psi (100kPa)
Max Water Pressure	115psi (800kPa)
Min Water Flow	2.1 gallons/min (8 liters/min)
Max Water Temperature	104°F (40°C)

Important! If the water pressure exceeds maximum specification then a pressure reducing valve is required and must be supplied and fitted by the installer.

WATER CONNECTIONS

A permanent water supply is required to be connected to the cooler. The water connection point is located on the underside of the cooler pan (reservoir). You must install a manual 1/4 turn ball type shut off valve (do not use a stop cock) in the water supply line adjacent to the cooler, subject to local plumbing regulations. This allows the water supply to be isolated whenever work needs to be done on the cooler.

COOLERS WITH DRAIN VALVES

For coolers with the inlet solenoid valve fitted, the water connection is a 1/2" BSP compression fitting on the end of a flexible hose. The flexible hose is connected to the float valve. The 1/2" BSP Compression fitting can be directly screwed onto the water pipe or be directly screwed onto the manual water shut-off valve. Always ensure that the water pipe connection does not place sideways strain onto the float valve.

Important! In areas subject to freezing, the water supply line to the cooler requires a drain down facility at the lowest point in the water supply pipe.

Important! Flush the water pipe to remove any swarf before final fitting. Swarf can lodge in the solenoid and float valve, preventing them from functioning correctly.

INSTALLING THE INLET SOLENOID

For coolers fitted with a drain and solenoid valve, it is a requirement to fit the new detachable hose set as supplied. Any old hose sets should not be re-used.

For EXQ model coolers, fit the inlet solenoid under the pan (reservoir) as shown:

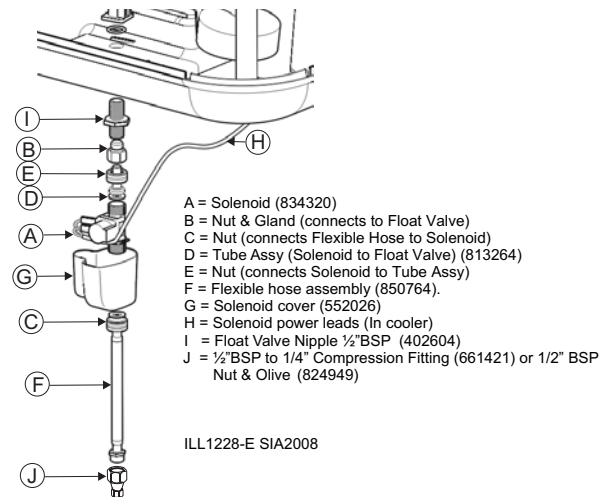

NOTE: Lead must wrap underneath solenoid barrel while cover is attached.

ILL1228-E SIA

Use thread seal tape between solenoid hose assembly and brass 1/2" BSP to 1/4" compression adaptor or 1/2" BSP Nut.

Note! Tighten the solenoid valve until it seals against the rubber washer and is in the orientation shown such that the solenoid cover will clip on over the top.

The water solenoid is required to be installed in the direction of flow as per the arrow indicator on the solenoid.

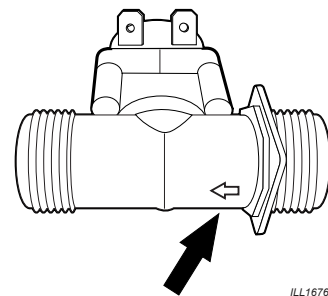

ILL1676-A

Ensure washers are correctly located. Do not over tighten plastic fittings.

Insert the solenoid cable through the hole in the cooler pan (reservoir) (behind the drain valve) and connect to the water solenoid valve. Make sure the cable is fitted to the groove underneath the pan so it does not get trapped by the solenoid cover when fitted. The cable leads can be connected to the solenoid either way around.

Important! The cable must wrap underneath the solenoid.

INSTALLATION

FITTING THE SOLENOID COVER

Once the solenoid valve and its cable has been fitted, place the cover over the assembly. Make sure the solenoid valve cable is retained in the groove in the cooler pan (reservoir). Secure the cover by tightening the flexible hose assembly nut (C).

Important! Make sure the cable cannot lay in the water at any stage. Connect the electrical leads to the solenoid.

The electrical cable leads may be connected to the solenoid either way around.

Taps or shutoff valves used must not be of the non - return type.

Water drained from the cooler must be carried away to a suitable discharge point in accordance with local regulations.

INSTALLING THE DRAIN VALVE

Water drained from the cooler must be carried away to a suitable discharge point in accordance with local regulations.

Important! Never drain water from the cooler directly on to the roof.

DRAIN VALVE ASSEMBLY

Assemble the drain valve as shown:

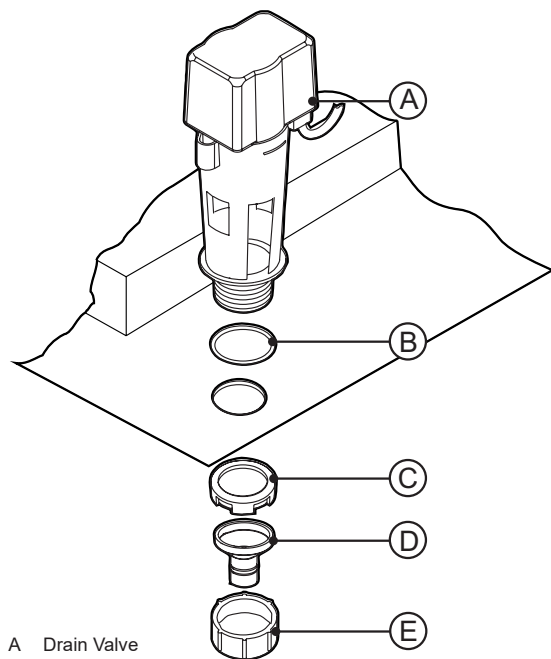

- A Drain Valve
- B O-Ring
- C Nut
- D Drain Adaptor
- E Lock Nut

ILL746-E

Make sure the "O"-ring (B) is fitted before placing the drain valve into the hole.

Screw the nut (C) up tightly by hand underneath to locate the drain valve.

Locate the drain adaptor (D) up against the bottom of the drain valve thread and secure with the second, larger nut (E).

Make sure that you use the correct drain adaptor. Make sure the drain water discharge flows freely away from the cooler.

Important! Do not over-tighten plastic fittings.

Connect the drain valve cable to the cooler electronics box.

CONNECTING THE MAGIQTOUCH CONTROLLER

Refer to the installation manual provided with the wall controller for instructions on installing the controller. Coolers are supplied with a 66' (20m) control cable. Longer cable lengths are available from Seeley.

Important! The maximum cable length allowed from the MagIQtouch controller to the first cooler is 82' (25m). For any additional coolers added into the system with a link module the maximum allowed length is 131' (40m). Therefore, failure of the product or components to operate correctly due to modification to supplied cables, or the use of non-approved cables will NOT be accepted under the Manufacturer's Warranty.

We have this cable available through our sales order office and spare parts outlets in the following lengths:

Part No.	Length	Details
833880	66' (20m)	MagIQtouch Controller Cable (No Ferrite)
862873	5' (1.5m)	MagIQtouch Controller Cable (No Ferrite)
861265	10' (3m)	MagIQtouch Controller Cable (No Ferrite)
864396	98' (30m)	MagIQtouch Controller Cable (With Ferrite)
864402	131' (40m)	MagIQtouch Controller Cable (With Ferrite)

COMMISSIONING

Once the controller is connected, power up the cooler using the ON/OFF switch on the cooler electronics box.

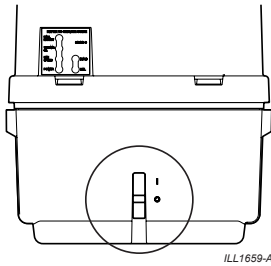

IMPORTANT NOTES:

- The cooler electronics box is a non-serviceable part. Do not open or attempt to repair any components.
- The cooler electronics box cover will only open and close with the ON / OFF switch in the "OFF" position. Do not try to force the cover open with the switch in the "ON" position.
- Always turn "OFF" mains power to the cooler before checking connections or touching wiring and components connected to the cooler electronics box.
- Take care to position the cables into the cover slots when closing, so that they do not become caught or pinched.
- The cooler electronics box is fitted with a 12A re-settable circuit breaker. To reset the circuit breaker isolate power from the cooler, and push the manual reset toggle switch located on the base of the cooler electronics box.

DIAGNOSTIC LED

Look at the front of the cooler electronics box where 2 LEDs are situated on the right hand side. The top LED glows green or red acting as a diagnostic indicator. If the top LED is double flashing green, everything is OK, this is normal operation.

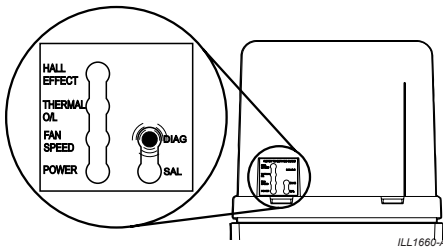

Colour	Flash	Indicates
No glow		No power or a failure has occurred. (Check power supply to cooler including isolating switch, circuit breaker and plug and socket connection in the roof space.)
Green	Every 2 sec	Normal Operation.
Red	1 Flash	Fault Code #1 Communication Failure.
	2 Flash	Fault Code #2 Failure to Detect Water at Probes.
	4 Flash	Fault Code #4 Failure to Clear Probes during drain.

SALINITY LED

The bottom LED is red only and displays salinity setting information.

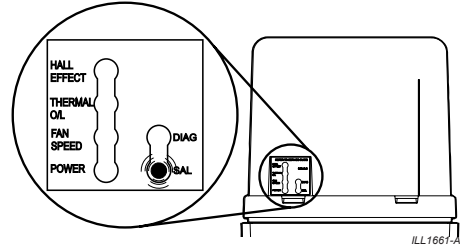

Sal Flash	Indicates
OFF	Not Applicable
1 Flash	WaterMiser® salinity is below the set point.
2 Flash	WaterMiser® salinity is above the set point.
3 Flash	The Salinity Control Method is set for Timed Drain
4 Flash	The Salinity Control Method is set for Continuous Bleed. (Bleed Funnel used)..
5 Flash	Thermostatic Control (no Water) operation set.
Continuously on (When probes immersed in water)	Water not detected. The probes are immersed in water but are open circuit, or measured salinity is less than 20µs/cm (the water has very little salt content).
Continuously on - (No water in Pan)	WaterMiser® / Drain Valve option is active

MAGIQTOUCH CONTROLLER INFORMATION

Diagnosis and cooler operating information can also be viewed from the MagiQtouch Controller. Faults are displayed on the screen as they occur.



Current cooler operation information can be temporarily displayed on the "Status Information Display" option in the GENERAL SETTINGS menu.

When this option is turned on, a temporary information display window becomes accessible on all MANUAL and PROGRAM screens.



COMMISSIONING

FAULT CODES

Fault Code 01 (1 Red Flash) = Communication Failure

- Ensure wall control cable is fitted correctly.
- Check the wall control cable is in good condition.

Fault Code 02 (2 Red Flashes) = Failure to detect water at probes within 8 minutes

- Ensure water pressure is sufficient to fill and maintain the pan (Reservoir) to specified level within 8 minutes.
- In areas of hard or polluted water, blockage of the strainer/ filter in the water inlet solenoid valve may restrict water flow.
- Water level set too low. For Breezair coolers the water level should be set to 13/64" (5mm) above the float valve base.
- Ensure probe plug is properly connected.
- Plug connections at electronic module are upside down or misaligned.
- Water too pure for the probes to sense water is present.
- Pressure build up in pipes can lock up the solenoid valve when a non-return isolation valve is used in the water supply line. It is recommended to use a ball valve, i.e. NOT a non-return type of shut off valve.
- Check drain valve is closing and not cycling due to debris being caught under drain valve washer.

Fault Code 04 (4 Red Flashes) = Failure to clear probes during drain within 4 minutes

- Check the drain valve opens and water drains from the pan (Reservoir), with nothing obstructing the outflow of water. (e.g. drain hose kinked)
- Excessive drain hose lengths or bends cause air locking and won't allow water to drain.
- Build up of foreign material in drain hose not allowing water to drain away correctly.
- Screws used to fix drain hoses to drain adaptors restricting water from draining from pan (Reservoir).
- Drain valve has failed to open when drain was initiated.
- Inlet water solenoid not shutting off water when the drain is open.
- Water will only flow one way through the inlet water solenoid valve. Therefore, it must be installed correctly. Directional arrow must be pointing towards the float valve assembly. If not, water will not shut off. (Directional arrow can be found on the bottom of the solenoid valve body).
- Debris interfering with water sensor probes.
- Probes not clipped onto mounting brackets correctly.
- Check cooler is level and water drains quickly.

TESTING THE DIRECT DRIVE MOTOR

This Breezair cooler incorporates a Seeley electronically commutated Direct Drive motor. No setup is required for this motor as it automatically adjusts to provide optimum output for each installation.

Turn the cooler on at the MagIQtouch Controller, in "FAN ONLY" mode. Look at the front of the cooler electronics box where 4 LEDs are situated on the left hand side. LEDs 1 - 4 should be on (glowing green).

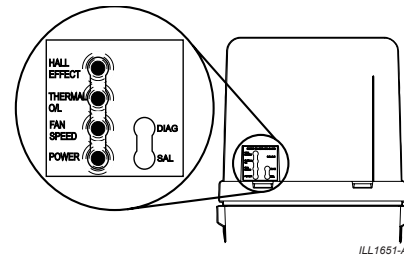

LED	Indicates
Hall Effect	ON = Normal operation. OFF = One or more Hall effects sensors in motor not detected.
Thermal O/L	ON = Normal Operation. OFF = Thermal Overload in motor tripped. (Caution! Motor in overload may re-start without warning).
Fan Speed	ON = Normal Operation. OFF or Flashing = Motor is not rotating within 30% of its set speed.
Power	Mains power is applied to the motor when the fan ON button of the controller has been pressed.

COMMISSIONING

SETTING THE WATER LEVEL

Isolate power to the cooler electronics and disconnect the pump, making sure the plug is kept away from any water. Turn the power back on.



ILL1663-A

Turn on the mains water supply to the cooler.

Turn the cooler on at the controller, in "COOL" mode.

Adjust set temperature slider / fan speed buttons to be close to current room temperature so that fan speed remains low.

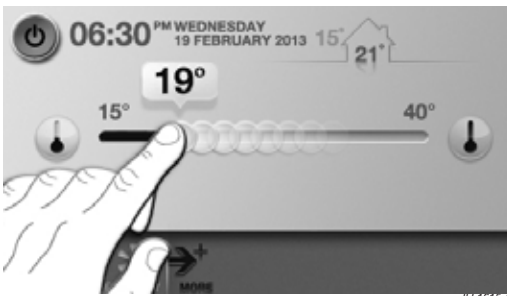

ILL1615-A

Allow the pan (reservoir) to fill with water. The float valve will eventually stop the water from entering the cooler. Wait for this to happen and check the water level.

If the level is too high rotate the float clockwise. Drain some water from the pan and allow it to refill to the new set point. If too low rotate the float in an anti-clockwise direction.

For EXQ models the correct water level is approximately 13/64" (5mm) above the surface of the pan (reservoir) the float valve is mounted on.

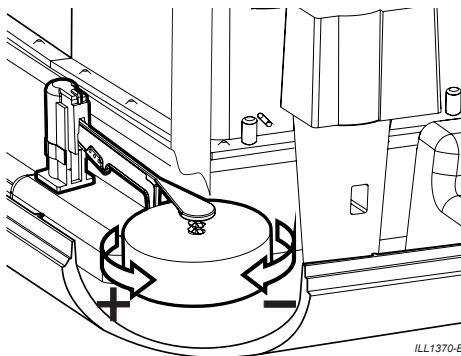

ILL1370-B

It is advisable to check the water level again after the float valve washer has "bedded in". Once the water level is correct, isolate the control box and connect the pump plug.

EXQ MODEL

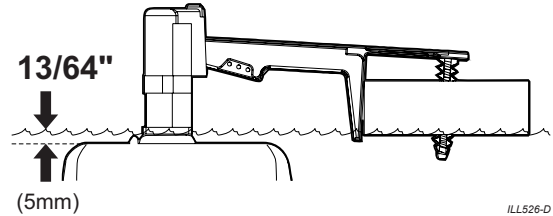

ILL526-D

TESTING THE DRAIN VALVE

Select the "SETTINGS" mode on the MagIQtouch Controller and select the "COOLER" sub-heading. Select the "MANUAL DRAIN" option to operate and test the drain valve.



ILL1638-B

TESTING THE PUMP

Test the pump by turning the cooler on at the MagIQtouch controller, in "COOL" mode. Check that water is evenly distributed to all pads.

Note! If the cooler has not been on before it will run a "Pre-Wet" routine where the pump will operate to saturate the pads. This cycle takes 2 minutes, then the fan will start automatically.

REFITTING THE PAD FRAMES

Refit the pad frames by locating the bottom edge in the pan (reservoir) groove, then push the top in under the lid.

Refit the corner clips after replacing the pad frame(s).

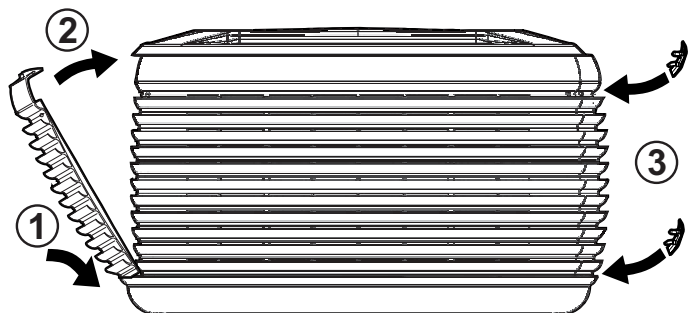

ILL1600-A

COMMISSIONING

ADJUSTING COOLER SETTINGS

Within the SETTINGS menu of the MagIQtouch Controller is the COOLER sub-heading. Here various settings of the cooler can be adjusted.

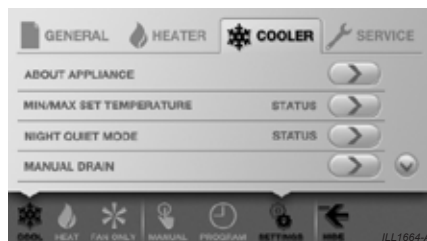

About Appliance

Displays information such as model number, serial number and software version for all coolers connected to the controller.

Min/Max Set Temperature

Defines the maximum and minimum temperature values.

Night Quiet Mode

Restricts fan speed to a specified level during a specified period.

Humidity Control (when Internal Air sensor is connected)

Set desired humidity levels.

External Air Sensor

Not fitted on EXQ models.

Manual Drain

Turns cooler off and drains the pan (reservoir).

Pad Flush

Turns cooler off and runs pump for a specified amount of time.

Drain And Dry

Cooler will drain and fan will run for 1 hour every day at a specified time.

Water Manager

Select the preferred water management method:

- Salinity Measurement - replaces water when Salinity level reaches set point.
- Timed Drain - drains pan (reservoir) After 8 pan fill cycles or every 1-2 hours (system dependant).
- No Drain Control - salinity control external to electronics eg. continuous bleed.
- No Water Thermostatic - allows Thermostatic control in VENT mode. No water present. Cooling performance is limited.

Weatherseal Open Speed

The cooler fan will turn on at the specified Weatherseal opening speed for the first 10 seconds each time it starts up. It will then return to the set fan speed.

Prewet

When COOL mode is activated, the pump will run for 90 seconds before the fan is switched on.

Salinity Level

Sets the salinity level at which the pan (reservoir) will drain in "SALINITY MEASUREMENT" mode.

Pan (Tank) Drain Delay

Sets the time delay before the drain valve opens after the pump in the cooler is turned off.

AutoClean

Select the preferred cleaning interval (50 / 100 / 200 hours). At 8.00am after the selected running hours has been reached, the cooler will drain the pan (reservoir), fill with fresh water and operate the pump for 5 minutes. When complete, drains the pan and returns to previous operation mode.

COMMISSIONING

COMMISSIONING COMPLETION CHECKLIST

COOLER

- SECURE - The cooler is secure and level on the roof jack using all fixings supplied.
- SEALED - The roof jack and all penetrations are correctly flashed and sealed.

WEATHERSEAL

- OPERATES - The Weatherseal operates correctly and can open and close without interference.

PLUMBING

- FLUSHED - The water pipes were flushed of any foreign materials before connection to cooler was made.
- NO EXTERNAL LEAKS - The water is connected with no leaks at fittings.
- NO INTERNAL LEAKS - Check all internal water hoses are securely fitted to water distribution spreaders and other internal fittings.
- SECURE - Water pipes are correctly saddled as per plumbing regulations.
- OWNER INSTRUCTIONS - The owner has been instructed on how to isolate the water to the system in case of emergency.

DRAIN VALVE

- INSTALLED - The drain valve is installed correctly, as detailed in this installation manual.
- DISCHARGE - The drain water does not discharge onto the roof surface.
- WATER LEVEL - Water level has been set correctly, as detailed in this installation manual.
- TESTED - Drain the pan. Check the drain fittings and pipes, making sure there are no leaks.

POWER

- REGULATIONS - The power supply adheres to all local and national regulations and is wired back to the distribution board on its own separate circuit.
- CHECK CABLES - Cables have been correctly connected to the control boxes:
 - Power supply
 - Motor cables (x2)
 - Control cable
 - Drain valve
 - Solenoid cable
 - Pump cable
 - Probe cable
- OWNER INSTRUCTIONS - The owner has been instructed how they can electrically isolate the unit at the meter box in case of an emergency.

DUCTWORK

- NO LEAKS - All ducts are hung correctly and there are no air leaks.
- CONTROLLER SEALED - All wall holes behind the MagIQtouch controller have been sealed.
- QUIET - Check that the cooler runs quietly and with an even distribution of air to all outlets.
- AIR BALANCE - The air balance for all outlets has been adjusted to the customer's satisfaction.

FLUSHING CHILLCEL PADS

- PADS FLUSHED - To prevent initial start-up odours from the cooling pads, it is a requirement to flush water through them and drain the pan. Operate in COOL mode, lowest speed for 5 minutes, then drain the pan. Repeat several times if necessary.

FINAL TEST

- Once you are satisfied that the cooler is installed and commissioned correctly, run the cooler and ensure that everything is working as it should.

CUSTOMER HANDOVER

- Principles of Ducted Evaporative Cooling explained.
- How far the windows need to be opened.
- How to turn the cooler on.
- How to operate the MagIQtouch controller.
- How to drain the cooler.
- How to isolate power and water to the cooler.
- Maintenance Schedule requirements.
- The customer has been given the owner's manuals & warranty card.

CLEAN-UP

- All the installation rubbish has been removed and, if applicable, any property damage repaired. Your aim should be to have the customer not even be aware that you have been on site.

FINAL CHECK

- With all chillcel pads and panels in place and the unit running for a short period in cooling mode, ensure all pads have even water saturation and there are no visible water leaks.

COMMISSIONING

TROUBLE SHOOTING

Symptom	Cause	Action
Inadequate cooling	Under-sized cooler.	Replace with larger cooler.
	Under-sized ducts.	Carry out cooling load design to determine correct size unit, ducting and outlets required.
	Clogged or dirty cooling pads.	Clean or replace pads.
	Dry pads or lack of water while cooler is operating.	Check water distribution system for possible obstruction in hoses. Check pump.
	Insufficient air discharge openings or inadequate exhaust from building, causing high humidity and discomfort.	Make sure there is adequate provision for exhausting stale air from building (open windows and doors).
	Excessive ambient humidity (see also item above re inadequate exhaust).	On days during summer when ambient humidity is high the cooler will not reduce the temperature as much as on drier days. There is no remedy except to shut off the pump.
Noisy cooler	Fan out of balance due to dirt. etc.	Clean the fan.
	Too much back pressure. Tight duct bends. Grilles too small.	Re-evaluate design; improve duct layout; change grille sizes.
Pump fails to operate.	Circuit breaker tripped.	Check pump for faults. Replace if necessary.
	Pump motor failure.	Replace pump.
Fan fails to start.	Main power circuit breaker tripped.	Check cause of overload. Reset circuit breaker.
	Fan motor burned out.	Replace motor.
	Low system voltage.	Consult with power supply authority.
	Check fault condition via the tri-colour LED on cooler electronics box.	Rectify fault as indicated and restart the cooler.
	MagIQtouch Controller failure.	Replace MagIQtouch Controller.
Pump runs but no water circulation / Pump runs but pads lack water	Insufficient water in pan (reservoir).	Adjust float level.
	Water hoses blocked.	Check and clean out blockage.
	Pump strainer blocked.	Clean pump strainer.
	Insufficient water supply pressure	Check and confirm water supply pressure
	Water solenoid is installed incorrectly	Check installed in the correct water flow direction
Continuous overflow of water.	Float valve adjustment not correct.	Adjust float valve.
	Heavy pad deposits.	Clean or replace pads.
	Drain Valve failure.	Replace Drain Valve.
	Water solenoid is installed incorrectly	Check installed in the correct water flow direction
Water entering cooler outlet.	Loose water hose connections.	Tighten connections.
	Water hose broken.	Replace cracked or broken hoses.
	Cover not fitted on float valve.	Replace float valve.
	Pads not fitted correctly into pad frames.	Install pad frame correctly.
	Incorrect or damaged pads.	Replace with new Chillcel pads.
Unpleasant odour.	New cooler pads.	Fill pan (reservoir), run pump for a short period to wash pads, drain pan, refill and repeat several times if odour persists. Odour will dissipate after a number of hours of operation.
	Cooler located near source of unpleasant odour.	Remove source of odour or relocate cooler.
	Algae in pan (Reservoir) water.	Drain pan, clean thoroughly with strong cleansing agent, refill, change pads.
	Pads remain wet after shut down.	Run fan on "vent" for 10 minutes after cooling cycle to dry pads out.
	Heavy pad deposits.	Clean or replace pads.
Air Sensor (optional) not working	Air Sensor not plugged into the control box	Plug Air Sensor cable into the electronics control box.
	Air Sensor failure	Replace Air Sensor

NOTES



EXQ
Cooler Installation Manuals

Now provided on the internet
available in English and Spanish
Refer www.seeleyinternational.com

Spanish

Manual de la Instalación del
climatizador del EXQ ahora
proporcionado en el Internet.



Service - All regions: Please contact your local distributor.
seeleyinternational.com

MANUFACTURED BY: SEELEY INTERNATIONAL PTY LTD
112 O'SULLIVAN BEACH RD, LONSDALE SA, 5160. AUSTRALIA

IMPORTED BY: SEELEY INTERNATIONAL (EUROPE) LTD
*UNIT 11 BYRON BUSINESS CENTRE DUKE STREET HUCKNALL,
NOTTINGHAM, NG15 7HP UNITED KINGDOM*

SEELEY INTERNATIONAL (AMERICAS) LTD
*1002 S 56TH AVENUE, SUITE # 101
PHOENIX, ARIZONA 85043, USA*

SEELEY INTERNATIONAL (AFRICA) PTY LTD
*6 WITTON ROAD, FOUNDERSVIEW SOUTH,
MODDERFONTEIN 1609, GAUTENG, SOUTH AFRICA*

It is the policy of Seeley International to introduce continuous product improvement.
Accordingly, specifications are subject to change without notice.
Please consult with your dealer to confirm the specifications of the model selected.

Breeze
By **SEELEY INTERNATIONAL**

seeleyinternational.com