

This Owner's Manual is provided and hosted by [Appliance Factory Parts](#).



# MHP AMCTSS Owner's Manual

[Shop genuine replacement parts for MHP AMCTSS](#)



[Find Your MHP Grill Parts - Select From 101 Models](#)

----- Manual continues below -----



*American Modern Classic*

# AMC Owner's Manual

## Assembly and Maintenance Instructions

**THIS GAS APPLIANCE IS DESIGNED FOR OUTDOOR USE ONLY.**



AMCTSS



AMCWSS



AMCJSS



AMCTMPB



AMCWMPB



AMCJMPB



AMCTMPP



AMCWMPB



AMCJMPP



### FOR YOUR SAFETY

If you smell gas:

1. Shut off gas to appliance.
2. Extinguish any open flame.
3. Open Lid.
4. Of odor continues, immediately call your gas supplier or your fire department.



### FOR YOUR SAFETY

1. Do not store or use gasoline or other flammable vapors and liquids in the vicinity of this or any other appliance.
2. An LP cylinder not connected for use shall not be stored in the vicinity of this or any other appliance.



### FOR YOUR SAFETY

Follow all leak-test procedures carefully in this manual before using. Do this even if the grill was dealer assembled. Do not try to light this appliance without reading the "Lighting" instructions in this manual.

**THESE INSTRUCTIONS SHOULD BE LEFT WITH THE CUSTOMER. KEEP THESE INSTRUCTIONS FOR FUTURE REFERENCE.**

**YOU MUST READ THIS OWNERS MANUAL BEFORE OPERATING YOUR GAS GRILL.**

# Safety





















**DANGER**



**WARNINGS**

**Failure to follow the Dangers, Warnings and Cautions contained in this Owner's Manual may result in serious bodily injury or death, or in a fire or an explosion causing damage to property.**

-  **CALIFORNIA PROPOSITION 65 WARNING:** Chemicals known to the State of California to cause cancer, and birth defects or other reproductive harm are created by the combustion of propane, charcoal, wood products, or natural gas used with this grill, and in the preparation of grilled foods
-  Do not store a spare or disconnected liquid propane cylinder under or near the barbecue.
-  Improper assembly may be dangerous. Please carefully follow the assembly instructions in this manual.
-  After a period of storage, and/or nonuse, the MHP Gas Barbecue Grill should be checked for gas leaks and burner obstructions before use. See instructions in this manual for correct procedures.
-  Do not operate the MHP Gas Barbecue Grill if there is a gas leak present.
-  Do not use a flame to check for gas leaks.
-  Combustible materials should never be within 18 inches of the bottom, back or sides of your MHP Gas Barbecue Grill.
-  Do not put a barbecue cover or anything flammable on, or in the storage area under the barbecue.
-  Children should never use your MHP Gas Barbecue Grill. Accessible parts of the barbecue may be very hot. Keep young children away while it is in use.
-  You should exercise reasonable care when operating your MHP Gas Barbecue Grill. It will be hot during cooking or cleaning and should never be left unattended, or moved while in operation.
-  Should the burners go out while in operation, turn all gas valves off. Open lid and wait five minutes before attempting to relight, using the lighting instructions.
-  Do not use charcoal or lava rock in your MHP Gas Barbecue Grill.
-  Never lean over open grill or place hands or fingers on the front edge of cooking box.
-  Do not enlarge the valve orifices or burner ports when cleaning the valves or burners.
-  The MHP Gas Barbecue Grill should be thoroughly cleaned on a regular basis.
-  Liquid propane gas is not natural gas. The conversion or attempted use of natural gas in a liquid propane unit or liquid propane gas in a natural gas unit is dangerous and will void your warranty.
-  Do not attempt to disconnect any gas fitting while your barbecue is in operation.
-  Use heat-resistant barbecue mitts or gloves when operating barbecue.

## LIQUID PROPANE GAS UNITS ONLY





-  Use the regulator that is supplied with your MHP Gas Barbecue Grill.
-  Do not attempt to disconnect the gas regulator or any gas fitting while your barbecue is in operation.
-  A dented or rusty propane cylinder may be hazardous and should be checked by your local liquid propane supplier. Do not use a liquid propane cylinder with a damaged valve.
-  Although your liquid propane cylinder may appear to be empty, gas may still be present, and the propane cylinder should be transported and stored accordingly.
-  If you see, smell or hear the hiss of escaping gas from the liquid propane cylinder:
  1. Move away from the liquid propane cylinder.
  2. Do not attempt to correct the problem yourself.
  3. Call your fire department.

TABLE OF CONTENTS	
<b>Safety (Dangers &amp; Warnings)</b> .....	2
<b>Warranty</b> .....	4
<b>General Instructions</b> .....	5
<b>Mountings</b> .....	6-7-8
<i>In-Ground Post</i> .....	6
<i>Deck/Patio</i> .....	7
<i>Portable Base</i> .....	8
<b>Grill Head Assembly</b> .....	9-10-11
<b>Gas &amp; LP Tank Connections</b> .....	12-13
<b>Leak Testing &amp; Lighting The Grill</b> .....	14
<b>Maintenance</b> .....	15-16
<i>Annual Maintenance</i> .....	15
<i>General Maintenance</i> .....	16
<b>Tube Bending</b> .....	12
<b>Cooking Techniques</b> .....	17
<b>Troubleshooting</b> .....	18
<b>Parts Information</b> .....	19

## ***MHP Grill Upgrade Options For Added Versatility, Convenience And Cooking Enjoyment.***



**Stainless Steel Side Burner.**  
The premium commercial grade stainless steel side burner is 12,000 BTU rated, has its own electronic ignition, and is factory assembled for simple drop-in installation.

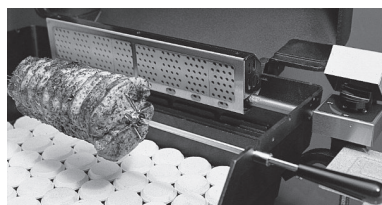

**Infra-Roast™ Rotisserie Burner System.** Infra-red rear burner heats up fast to quickly put a seal around meats for juicier and more moist results. Constructed of commercial grade stainless steel and is easy to install or remove for normal grilling.

# ***MHP AMC Series Warranty***

## **LIMITED LIFETIME WARRANTY ON THE FOLLOWING:**

**(Against Rust Through)**

**Cast Aluminum Top Casting & Bottom Casting • Grill Posts**

## **10-YEAR WARRANTY ON THE FOLLOWING:**

**(Against Rust Through)**

**Stainless Steel Burner • 3 Piece Stainless Steel Column Base • Control Panel  
Stainless Steel Grill Top Insert • Stainless Steel Shelves • Stainless Steel Grids**

## **5-YEAR WARRANTY ON THE FOLLOWING:**

**Porcelain Briquettes • Stainless Steel Briquette Grate**

## **1-YEAR WARRANTY ON THE FOLLOWING:**

**(Against Rust Through)**

**All other Components Including:**

**Ignitor System • Gas Valves • Knobs • Wheels • Casters • Nu-Stone Patio Base**

**Anything not stated above falls under the 1-Year Warranty**

## **30 Day Warranty on Paint**

*There is a 1 year warranty on all parts if grills are put into commercial, multi-unit or community use.*

## **WHAT IS NOT COVERED:**

Transportation and shipping cost • Labor for replacement or repairs • Damage from accident, misuse, alteration, abuse, improper installation or storage • Removal and reinstallation costs • Finishes on surface that are damaged by improper installation, improper storage, accident, misuse, abuse or alteration • Inoperable due to improper installation or storage • The costs of a service call to diagnose a problem • All warranties are non-transferable and apply only to the original purchaser • This warranty does not imply or assume any responsibility for consequential damages that might result from use, misuse, or improper installation of this cooking appliance. This warranty does not cover claims which do not involve defective work-

## **MODEL IDENTIFICATION**

Your MHP Patriot Series Grill is identified by a model number and a serial number located on the left side of the control panel. Always use both the model and serial numbers when contacting Modern Home Products about your grill. For future reference, take the time now to record the model and serial numbers below:

**MODEL NUMBER:** \_\_\_\_\_ **SERIAL NUMBER:** \_\_\_\_\_ **DATE PURCHASED:** \_\_\_\_\_

**How to contact us:** phone: 1-888-647-4745, fax: 1-800-637-2918, E-mail: [customerservice@mhpgrills.com](mailto:customerservice@mhpgrills.com) or write: Customer Service, Modern Home Products, 150 S. Ram Road, Antioch, Illinois 60002.

# General Instructions

## GENERAL INSTRUCTIONS

This installation guide provides you with easy to follow illustrations and instructions to assemble your MHP Gas Barbecue Grill.

**Before you start assembling and using your MHP Gas Barbecue Grill we recommend that you read through all precautions, safe guards and instructions to avoid any personal injury or property damage.**

**Check Local Codes.** Contact your local LP dealer or Natural Gas company for recommended installation procedures and regulations. If there are no local codes, installation must conform to the latest National Fuel Gas Code: ANSI Z 223.1. For Canada, installation must comply with local codes and/or Standard CAN/CGA-B-149-1 for natural gas installation and CAN/CGA- B-149-2 for propane installation.

For LP Gas Models the supplied Regulator must be used. Any replacement pressure regulator or hose assembly must meet or exceed the specifications of MHP. Refer to the parts list and contact the dealer where your grill was purchased.

Only Worthington, Manchester, or Wolfdale brand cylinders should be used with this appliance.

For Natural Gas Models the grill is designed to operate at a pressure of 7" water column (W.C.) (1.75 kPa). Check your gas utility for local pressure. Pressures other than approximately 7" W.C. could affect the performance of your grill.

## ASSEMBLY INSTRUCTIONS

There are 9 steps to assembling your MHP Gas Barbecue Grill: The mounting, LP tank mounting, control panel, gas supply connection, grill lid, lid handle, side shelves, and rock grate, cooking grid and warming rack.

The grill itself is partially assembled with the Burner, Venturis, Ignitor Collector Box and the Regulator installed.

## TOOLS NEEDED FOR ASSEMBLY



Phillips and Straight  
Screw Driver



7/16 Socket or Nut  
Driver



7/16 Wrench

## STORAGE











Turn gas OFF at the LP cylinder (or at the shut OFF valve in the case of Natural Gas) when the MHP Gas Barbecue Grill is not in use.

Do not store spare LP cylinders under the MHP Gas Barbecue Grill.

Store disconnected LP cylinders outdoors in a well-ventilated area, do not store in shed, building, garage or in any enclosed area.

Place dust cap on cylinder valve outlet whenever the cylinder is not in use. Only install the type of dust cap on the cylinder valve outlet that is provided with the cylinder valve. Other types of caps or plugs may result in leakage of propane.

## OPERATING SAFEGUARDS

-  **Do not install your MHP Gas Barbecue Grill in or on recreational vehicles and/or boats.**
-  **Never use your MHP Gas Barbecue Grill near combustible surfaces, including roof overhangs, roofs, vinyl siding and window shutters.**
-  **Use this barbecue outdoors in a well-ventilated area.**
-  **Do not use your MHP Gas Barbecue Grill in a shed, garage, building, breezeway or any other confined area.**
-  **Do not use any kind of combustible material on or near the top, bottom, back or sides of the grill. Maintain at least an 18 inch clearance.**
-  **Leak test all gas supply line connections.**
-  **Do not let children operate a gas grill.**
-  **Keep the area around the grill clear of combustible vapors or liquids such as gasoline.**
-  **When operating the grill do not leave unattended. Keep children and pets away.**
-  **Keep fuel supply hose and electrical supply cord away from any heated surface.**

## SAFETY

**YOUR GRILL IS DESIGNED FOR OUTDOOR USE ONLY.**

It should also not be used in an enclosed area such as a shed or garage because combustion uses available oxygen and discharges carbon monoxide.

The grill must be located no closer than 18" from any combustible surface behind or to the sides. Grill should not be located under overhead unprotected combustible surfaces.

Keep the area around the grill clear of combustible materials, flammable vapors or liquids such as gasoline.

Do not obstruct the flow of combustion and ventilation air.

# Mounting

## In-Ground Post

Please check to be sure that all parts are included before proceeding. Contact your dealer if any parts are missing.

Parts	Quantity
4' Post	1
Post access door	1
28" Stainless Steel Tubing	1
Stainless Steel Grease Cup	1
Stainless Grease Cup Holder	1
1/4 - 20 x 3/4" Hex Head Bolts	3
1/4 - 20 Kep Nuts	3

3. Mount the grease cup holder to the rear flange hole with a 1/4 - 20 x 3/4" bolt and 1/4-20 Kep nut. The grease cup holder is supplied with the grill head.

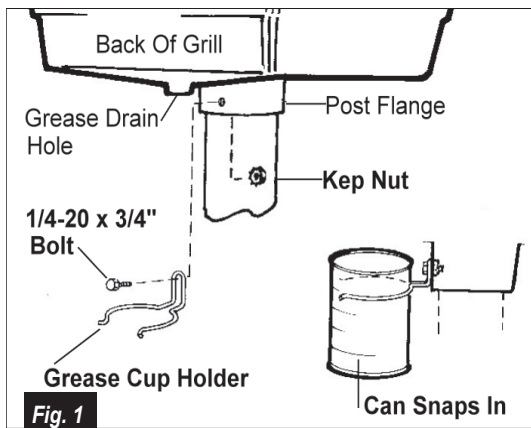

When you complete the mount assembly go to the appropriate Grill Assembly Section and assemble the grill head.

### In-Ground Mounting Assembly Instructions (MPP)

- All MHP Grill Heads may be mounted on the 4 foot post for in-ground installation.
- The gas supply may be either LP or Natural.
- The grill head should not be attached to the post until the post is permanently cemented in ground.

#### Step 1: In-Ground Mounting Installation (Fig. 5)

1. Dig a posthole about 8 inches wide by 2 feet deep. **Caution:** Locate the hole so that the mounted grill head has a clearance of 18 inches away from any combustible object or surface; back, left or right.  
Center the post in the hole and plumb it. Pour in cement (gravel) up to the gas line access hole.

Keep in mind that the gas line access hole is on the back of the post and the notch at the top if facing front. Recheck plumb and allow cement to set.

2. Run the gas supply line into the post access hole (just above the cement). Make a 90° bend to reach the access door opening. The gas supply line should be trenched at least 18 inches below the surface of the ground to prevent damage from digging. **CAUTION: The gas supply line must be regulated (in the case of natural gas that means connected after your gas meter and regulator) and that you have an easily accessible shut-off valve.**
3. At the access door connect a 3/8" flare coupling (not supplied by MHP) to the gas supply line and Stainless Steel tubing. Position the tubing in the top notch of the post. Bend the tubing at the top end to match the Feed Line of the grill valve. **Do not kink the tubing.**

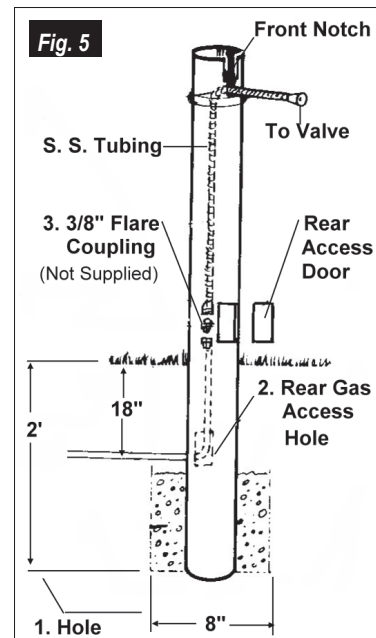

**TUBE BENDING:** For proper bending of the stainless steel tubing, see page 12 for bending instructions.

#### Step 2: Attaching The Grill Head Bottom To The In-Ground Post (Fig. 1 & 2)

To attach the grill head to the post please refer to Step 3 of the Deck/Patio installation procedures on page 7 and follow instructions.

When you complete the mount assembly Go to the Grill head section and assemble the Grill Head.

Please check to be sure that all parts are included before proceeding. Contact your dealer if any parts are missing.

Parts	Quantity
2' Post	1
Patio Base	1
Post Access Door	1
Grease Cup Holder	1
28" Stainless Steel Tubing	1
Stainless Steel Grease Cup	1
<b>Hardware Kit</b>	
1/4 - 20 x 3/4" Hex Head Bolts	7
1/4 - 20 Kep Nuts	7
1/4" Flat Washers	7
8 - 32 x 1/2" Self Tapping Screw	1
Tube Clip	1

**•The grill head should not be attached to the post until the base has been mounted to the deck or patio.**

### Step 1: Deck/Patio Base Mounting Assembly (Fig. 3)

1. Turn base on edge and insert the 2' post. Align the notches in the post with the notches in the base. **IMPORTANT:** Close tolerances may require you to tap the top of the post to seat it completely in the base socket which will then align the bolt slots.
2. Fasten post to base with four 1/4 - 20 x 3/4" Hex bolts, washers and Kep nuts. Follow exact placement of washers as indicated. Tighten securely.
3. Attach the tube clip with the 8 - 32 self-tapping screw either on the right or left side of the base depending on the direction of your gas supply line.

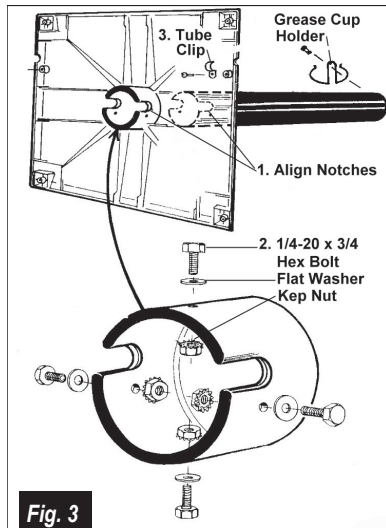

### Step 2: Deck/Patio Mounting Installation (Fig. 4)

Position the patio base at the desired location on a deck or patio.

**CAUTION:** Be certain there are no combustible materials above, behind, left or right closer than 18" away.

1. Mark the location of the four holes at the outside corners of the patio base and drill four holes. The base will be fastened down with lag bolts (not supplied by MHP) after you have connected the gas supply line. The top post notch is the front and the rear access door will be in the back of the grill.

## Mounting Deck/Patio Base

2. Run the gas supply line into the post from the bottom to reach the access door and bend it 90° to exit the base at either notch. The patio base is notched on two sides to allow the gas line to exit either right or left.
3. Secure the gas line with the tube clip. (Option: On a raised deck if the gas supply line is to be run straight up into the post from below use the tube clip to attach the gas line to the deck for support.)
4. At the access door connect a 3/8" flare coupling (not supplied by MHP) to the gas supply line and Stainless Steel tubing. Position the tubing in the top notch of the post. Bend the tubing at the top end to match the Feed Line of the grill valve. **Do not kink the tubing.**

**TUBE BENDING:** For proper bending of the stainless steel tubing, see page 26 for bending instructions.

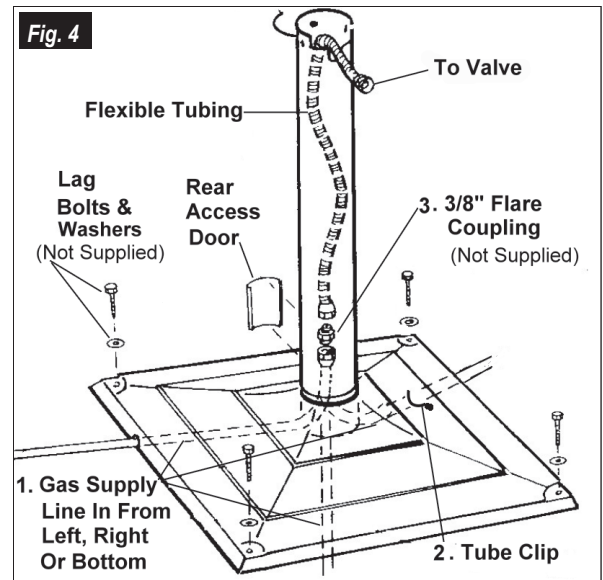

### Step 3: Attaching The Grill Head Bottom To The Deck/Patio and In-Ground Post (Fig. 1 & Fig. 2)

1. To make the post-to-flange connection easier, remove the grill burner by taking out the small clip located under the bottom grill head. This will allow access to hold the Kep nuts inside the post.
2. Set the grill head bottom carefully in place, align holes and use the 1/4 - 20 x 3/4" bolts and 1/4-20 Kep nuts to attach the grill flange to the post.

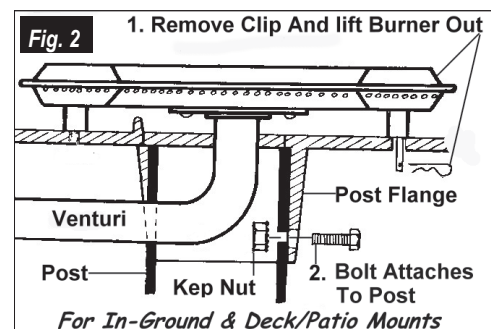

# Mounting

## Column/Portable Base

Carton contains the following column and base components for assembly: Please check to be sure that all parts are included before proceeding. Contact your dealer or the factory if any parts are missing.

Column	3 (Front, 2 Sides)
Tank Locking Bar (See Pre-Pack Below)	1 Pre-Pack
12 Ft. Hose with Quick Disconnect <i>(Natural Gas Model)</i>	1
Base	1
Locking Casters	4

HARDWARE	QUAN.	USE
1/4-20 x 1/2" Hex Head Bolt	12	Column to Base
KEP Nut	12	Column to Base
1/4-20 x 1/2" Hex Head Bolt	8	Heat Shield to Column
KEP Nut	8	Heat Shield to Column
1/4-20 x 1/2" Hex Head Bolt	16	Casters to Base

### Pre-Packaged Part and Fasteners

**Tank Locking Bar**—Nylon Spacer, 1/4" x 1" Hex Bolt (2), 1/4" Flat Washers (4) and 1/4-20 Kep Nuts (2).

**AMCW & AMCJ Handle Kits**—Handle End Caps (2), Graphite Gasket (2), 1/4 x 1" Hex Bolts (2), and Kep Nuts 1/4-20 (2)

**AMCW & AMCT Shelf Kit**—Shelf Brackets (4), Shelves (2), 1/4 x 20 x 3/4 Bolts (4), 10-24 Nylon Lock Nuts (4), and 1/4-20 Kep Nuts (8)

**AMCJ Shelf Kit**—Shelf Brackets (2), Shelves (1), 1/4 x 20 x 3/4 Bolts (2), 10-24 Nylon Lock Nuts (2), and 1/4-20 Kep Nuts (4)

**Control Panel Kit**—Valve Control Knobs (2), Rotary Ignitor Knob (1), 1/4 20 Kep Nuts (4), Control Panel Support Brackets (2), 1/4—20 x 1 1/4" Phillips Head Bolts (2), 1/4—20 x 1 1/2" Phillips Head Bolts and Venturi Tube Cleaner (1)

**Grill Head Kits**—Lid Pivot Pins (2), Hitch Cotter Pins (2), Wire Grease Cup Holder (Used for MPP & MPB Mounting Options)

### Step 1: Mounting Column to Base.

- Attach the front (center) section of the column to the base using (2) 1/4-20 x 1/2" hex head bolts and (2) 1/4-20 Kep nuts. **(Fig. A)**
- Attach the (2) sides of the column to the base using (4) 1/4-20 x 1/2" hex head bolts and (4) 1/4-20 Kep nuts. **(Fig. B)**
- Attach sides of column sections using (6) 1/4-20 x 1/2" hex head bolts and (6) 1/4-20 Kep nuts.
- Insert heat shield into top of column using (8) 1/4-20 x 1/2" hex head bolts and (8) 1/4-20 Kep nuts. **(Fig. D)**
- Lay base on its side and bolt casters into place with 1/4-20 x 1/2" Bolts at all (4) corners of base. **(Fig. E)**
- Attach the tank lock bar across the back of the column. Use the 3/4" Hex bolt, (4) 1/4" Flat Washers, Nylon Spacer and the 1/4-20 Kep nut on each side to fasten the bar in place. **(Fig. E-1)**

**NOTE: Finger tighten all bolts until the column is completely assembled on the base.**

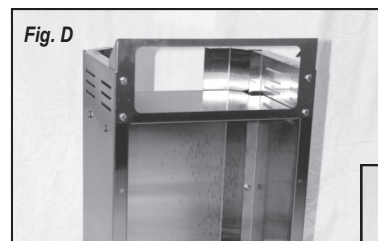
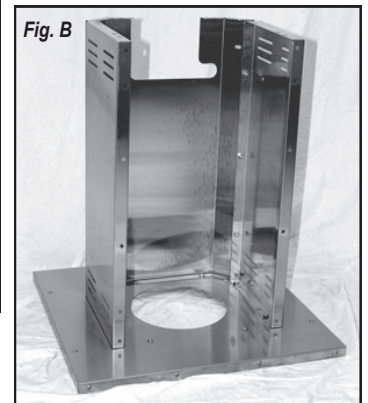
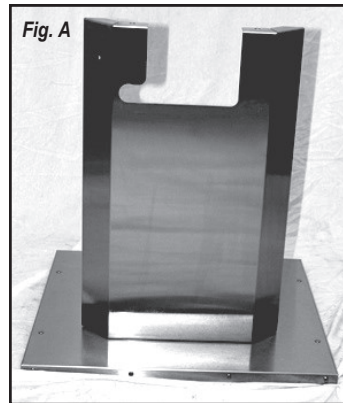

Heat Shield

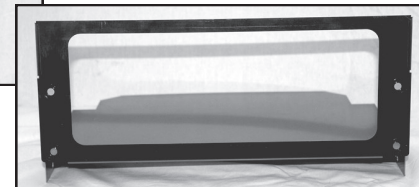

### Mounting Tank Locking Bar

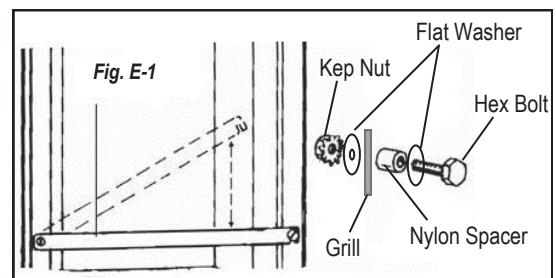

## View of Grill Head Components

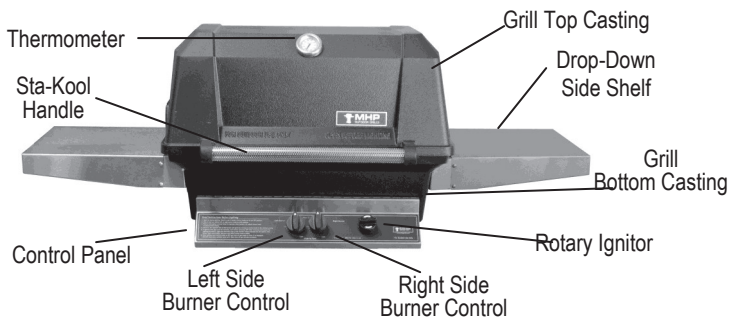

**AMCW & AMCT**  
Stainless Steel  
Swing Away  
Warming Rack

**AMCJ**  
Stainless Steel  
Drop In Style

(2) Stainless Steel  
Cooking Grids

## Step 1: Mounting Grill Head to Column

1. Attach the grill head bottom to the pedestal column top with four  $\frac{1}{4}$  - 20 x  $1\frac{1}{2}$ " Hex bolts, washers under the bolt head, and Kep nuts.

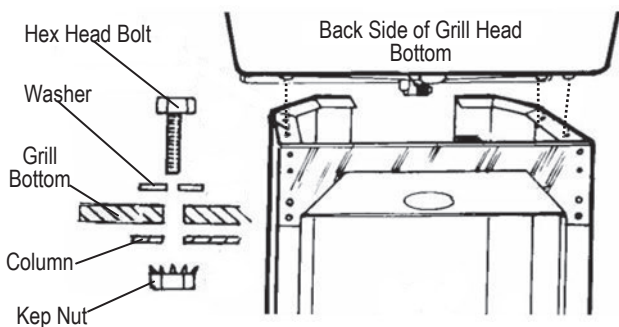

## Step 2: Control Panel & Heat Shield

### A. Attaching the Heat Shield and Control Panel Assembly (Fig. 6)

1. Attach the complete control panel assembly to the front of the grill head with  $\frac{1}{4}$ —20 Kep nuts.
2. Leave the (2) nuts holding the heat shield on, to serve as spacer nuts.
3. Make sure the valve orifices on the control panel aligns with the burner venturi correctly and that the venturi tubes go over the valve orifices at least  $\frac{1}{4}$ " to  $\frac{1}{2}$ " (see Fig. 9 page 10).

**Note: Hose and Regulator is Preassembled to the Valve At the Factory.**

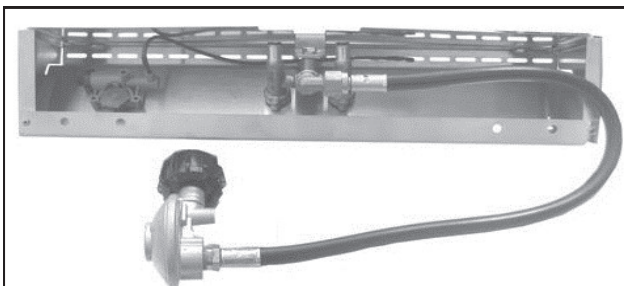

## Mounting Grill Head Assembly

### CONTROL PANEL ASSEMBLY - Rear View

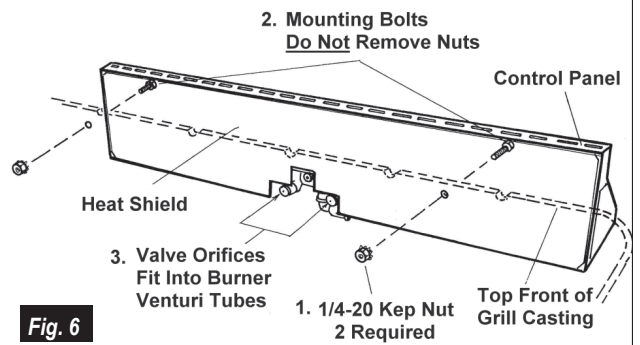

Fig. 6

### B. Connecting the Control Panel Support Brackets (Fig. 7)

1. Two support brackets are connected beneath the control panel to the grill head for added support. Push a  $\frac{1}{4}$  - 20 x  $1\frac{1}{4}$ " Phillips head bolt through the grill head from the inside.
2. Slip the support bracket in position, fasten with a  $\frac{1}{4}$  - 20 Kep nut.
3. Attach the control panel to the support bracket by pushing up a  $\frac{1}{4}$  - 20 x  $\frac{1}{2}$ " Phillips head bolt through the support bracket and through the lower lip of the control panel, fasten with a  $\frac{1}{4}$  - 20 Kep nut.

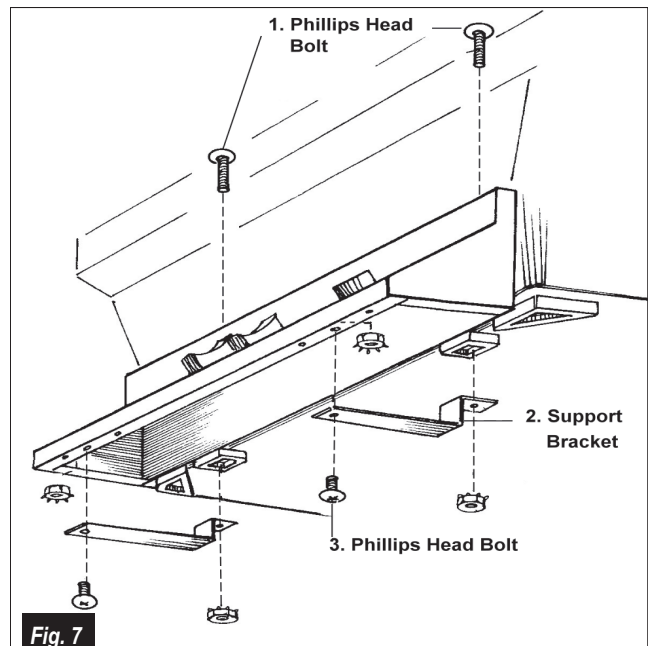

Fig. 7

### C. Ignitor Wire Connection (Fig. 8)

1. Tip the grill on its back (or upside down) and attach the control panel ignitor wire to the terminal sticking out from the bottom of the grill. **Be careful not to crack the delicate porcelain insulator.**

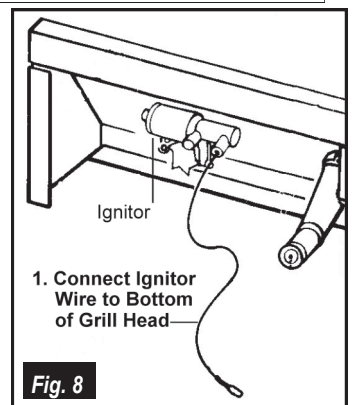

Fig. 8

# Mounting Grill Head Assembly

## D. Orifice Engagement (Fig. 9)

At the top end of each valve there is a tiny gas opening known as the orifice. Gas exits the orifice and enters a venturi where it mixes with air coming in from the side air shutter. The proper mixture of air and gas produces a clean blue flame at the burner.

Make sure the valve orifice on the control panel aligns with the burner venturi tube correctly. The orifice should fit into the venturi tube 1/4" to 1/2" inches as shown below.

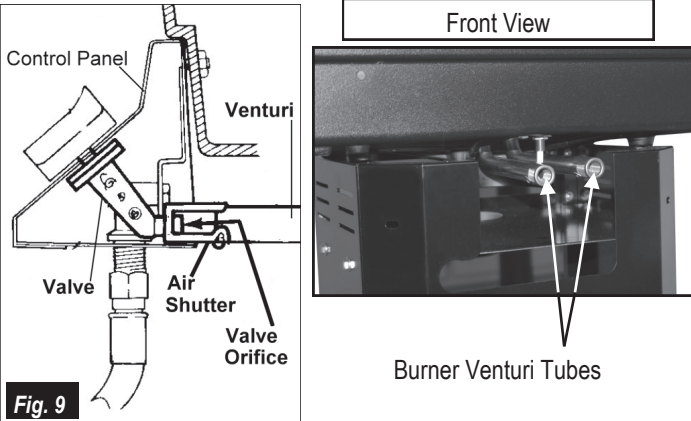

Fig. 9

**WARNING!** Always check the alignment of the orifice and the venturi whenever the grill has been moved. Make sure that the orifice fits into the venturi tube 1/4" to 1/2". Failure to make this connection may cause fire and result in serious body injury or damage to your grill.

## Connecting the Gas Supply Line

### LP Propane for portable base and deck/patio mounts:

The hose connection from the Regulator passes out the front access opening; resting on the protected slot edge beneath the control panel. The LP tank locking bar will press against the tank as it is lowered into place to prevent tank movement. (Fig. 10)

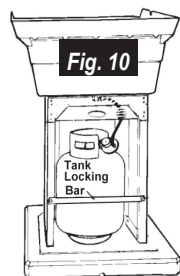

Fig. 10

### For Deck/Patio & In-Ground Mounts Using 30" Flexible tubing. (Fig. 11)

Connect the 30" flexible tube to the incoming gas supply using a 3/8" flare coupling (not supplied). Attach the other end to the grill valve connection behind the control panel. To tighten securely use two wrenches. Hold valve joint with one wrench and tighten the hose fitting with second wrench.

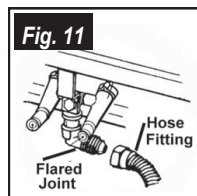

Fig. 11

### Natural gas hose for portable base mount:

The natural gas cart uses a 12 foot hose with a quick disconnect (supplied). The hose passes beneath the heat shield through the front access opening and connects directly to the control valve. The quick disconnect end attaches to the gas supply line at the shut-off valve. (Fig. 12)

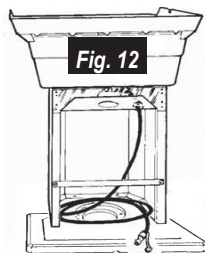

Fig. 12



**Tighten all gas connections securely and leak test both ends. See Leak Testing on page 14**

## Side Shelves Assembly

**Fold-Down Shelves Parts And Hardware:** Right Brackets (2), Left Brackets (2), Shelves (2), 1/4 x 20 x 3/4 Bolts (8), 1/4 x 20 Kef Nuts (8) and 10 x 24 Nylock Nuts (2)

### STEP 1

#### MOUNTING BRACKET TO GRILL (Fig. 13 and 14)

Attach Brackets to grill using **bolts** and **kep nuts** (2 bolts per bracket). Tighten nuts while making sure brackets are parallel with grill.

### STEP 2

#### ATTACHING SHELF TO BRACKET (Fig. 15)

Place the left bottom **shelf** post into the left bottom **bracket** slot. Gently spread the **shelf** apart to insert the right bottom **shelf** post into the right bottom **bracket** slot. Secure bottom posts with **Nylock Nut**—making sure nuts are snug but **don not** restrict movement of folding and unfolding of the shelf.

**Note: Top posts on shelf do NOT use nuts.**

## MOUNTING SHELF BRACKETS TO GRILL

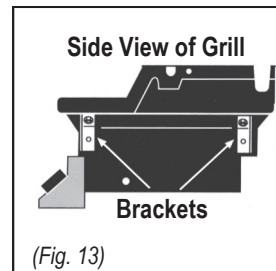

(Fig. 13)

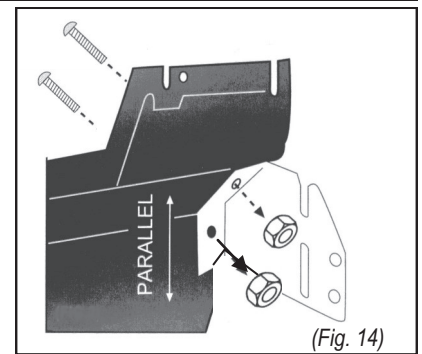

(Fig. 14)

## ATTACHING SHELF TO BRACKET

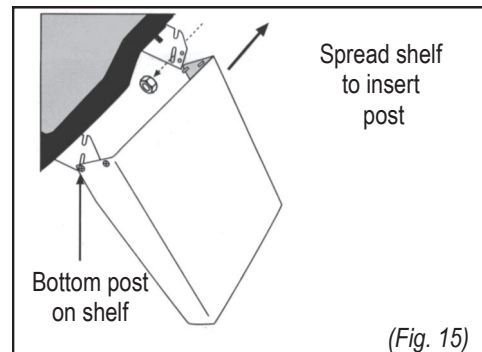

(Fig. 15)

## OPENING SHELF

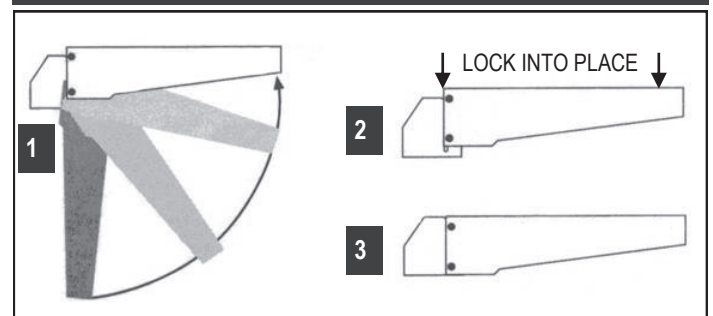

## Attaching the Grill Lid

1. Attach the grill lid to the grill head bottom using the two Hinge Pins and Hinge Clips. (Fig. 16)

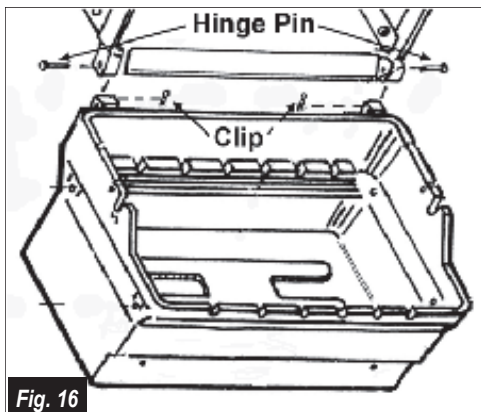

Fig. 16

## Connect the Handle (Skip Step for AMCT Models)

1. Attach the handle to the grill lid using two 1/4 - 20 x 1 1/2" Hex bolts with Kep nuts. Graphite Gaskets are positioned between the end caps and grill lid as shown in Fig. 17. Use two 7/16" wrenches, one to hold the bolt head and one to tighten the nut.

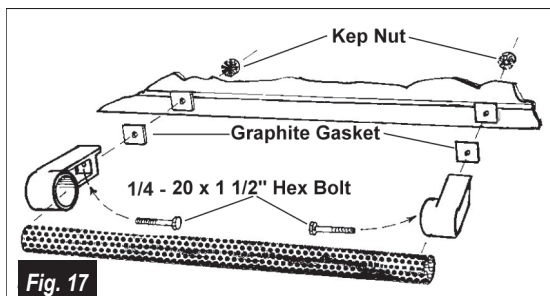

Fig. 17

## Grates, Briquettes and Cooking Grids (Fig. 18)

1. Place the one piece Briquette Grate on the shelf edge just above the burner.
2. Carefully place the Porcelain Briquettes on the grate in the pattern shown. Use only one layer.
3. Place the two Cooking Grids above the Briquette Grate.

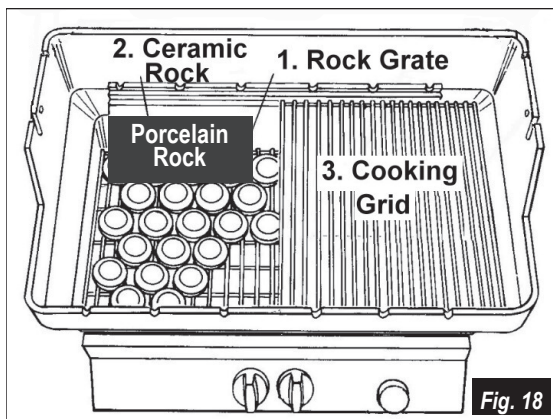

Fig. 18

## Mounting Grill Head Assembly

### Warming Rack

1. The AMCJ Warming Rack rests in the notches on the top edge of the grill head bottom. (Fig. 19)

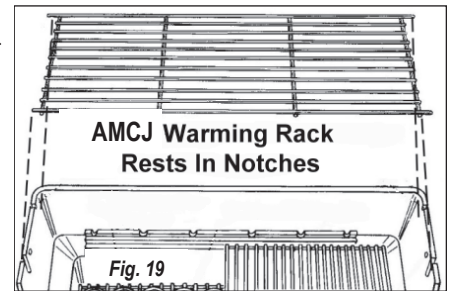

Fig. 19

2. The AMCW and AMCT swing-away Warming Rack connects to the grill lid and the grill head bottom. First, insert the right Top and Bottom Rods into their respective mounting holes on right side of the grill lid and grill head bottom. Then slide the RACK to your left, positioning the left Top and Bottom Rods into their respective mounting holes simultaneously. The Lower Right Rod End can then be "popped" into place by flexing it inward. (Fig. 34)

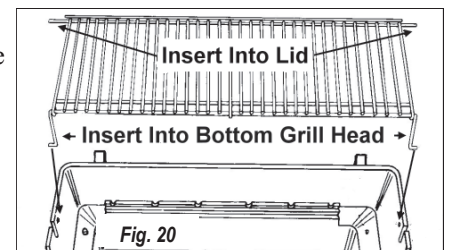

Fig. 20

### Thermometer

Install the thermometer through the hole in the center of the lid. Snug fit the thermometer to the lid using the thumb bolt.

**Do not over tighten**



**!** Before using your grill, leak test all gas line connections. And follow the lighting instructions. See page 14.

# Gas & LP Tank Connections

## GAS & LP CYLINDER

### Check Local Codes

Consult your local LP dealer or Natural Gas Company for recommended installation procedures and regulations. In the absence of local codes, installation must conform to the National Fuel Gas Code, ANSI Z223.1 or CAN/CGA-B149.1 Natural Gas Installation Code or CAN/CGA-B149.2, Propane Installation Code.

### Natural Gas Models

The grill is designed to operate on Natural Gas at a pressure of 7" water column (W.C.) [1.75 kPa]. Check with your gas utility for local gas pressure. Use of your gas grill at pressures other than approximate 7" WC could affect the performance of your grill.

### Natural Gas Hose & Inspection

A single hose of not more than 12 feet long (3.6 meters) is supplied with the cart-styled models.

Check the hose before each use at places where there could be extra bending, such as near the gas supply quick-disconnect coupling and at the grill valve connection. Look for cracking, cuts or heat damage. Check the entire length for cracking and excessive wear.

To replace the hose, turn off gas supply at valve. Release the quick-disconnect coupling. Using a wrench, disconnect hose from grill valve connection under the control panel, and clean threads.

Replace only with an identical hose from the manufacturer or an authorized dealer. **Do not use pipe joint compound on the flared fitting at the control panel grill valve connection.**

### LP Gas Models

The Grill using a **Type I** LP cylinder includes the Regulator. Any replacement pressure regulator or hose assembly must meet or exceed the specifications of the MHP.



**DO NOT CONNECT THE GRILL TO AN LP GAS CYLINDER GREATER THAN 20 LB. CAPACITY.**

LP Gas Cylinder Requirements: (The LP-Gas Cylinder is not supplied with your MHP Grill.)

The LP cylinder should be equipped with an OPD (Overflow Prevention Device) and a QCC! Or Type 1 (CGA810) cylinder connection. This cylinder connection is compatible with the grill connection. OPD is an internal mechanical device that limits the amount of liquid propane and prevents overfilling the LP cylinder. The correct filling methods for the filling of your cylinder are by weight or volume, as described in NFPA 58. Please make sure your LP dealer fills your LP cylinder by weight or volume. Ask your LP dealer to read purging and filling instructions on the LP cylinder before attempting to fill.

All LP cylinders supply systems must include a collar to protect the cylinder valve.

The LP cylinder must be a 20-LB size (18 1/4" high, 12 1/4" in diameter).

The LP cylinder must be constructed and marked in accordance with the specifications for LP-gas cylinders of the U.S. Department of Transportation (D.O.T.). In Canada, gas cylinders must meet Canadian LP Gas Tank Specification Code, National Standard of Canada, CAN/CSA-B339, Spheres and Tubes for the Transportation of Dangerous Goods and Commission.

Be sure your LP cylinder has a D.O.T. certification and has been tested within five years. This information is usually marked on the protective collar.



**WARNING:** If you use an LP tank exchange service, be sure that the exchanged tank is equipped with an OPD. If there is not an LP tank available for exchange equipped with an OPD, we recommend that you have your LP tank filled by an authorized LP dealer.

**DANGER:** Do not use an open flame to check for gas leaks. Be sure there are no sparks or open flames in the immediate area while you check for leaks. Sparks or flames will result in a fire or explosion which can cause serious bodily injury or death, and damage to property.

## FLEXIBLE STAINLESS STEEL GAS TUBE BENDING

For 2' & 4" Posts With Access Doors.

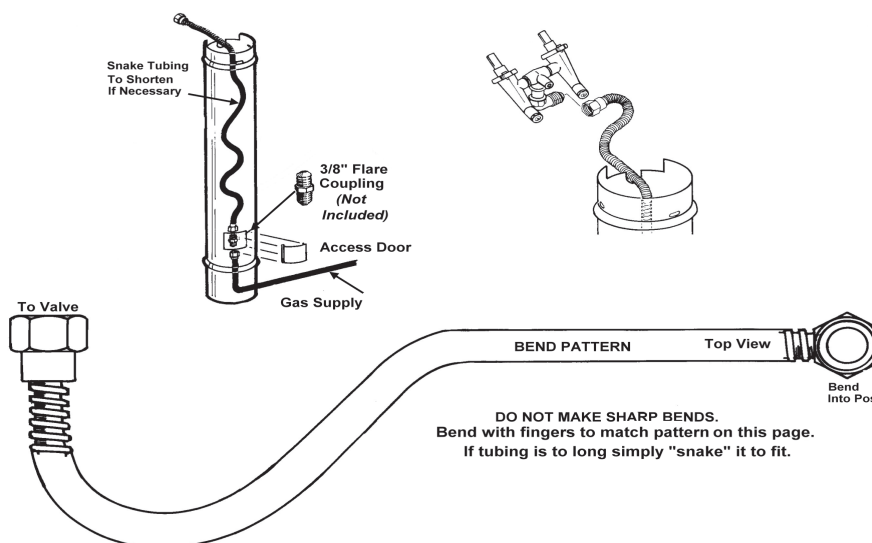

# Gas & LP Tank Connection

## CONNECTING THE LP CYLINDER (Fig. 19)

Install the gas cylinder in the back of your grill, with the open side of the tank valve collar pointing towards the square hole in the tank enclosure. Ensure that all hoses, fittings and regulators are properly protected from heat and accidental damage. Hoses can be burned or chafed if routed improperly. (See Hose and Regulator, page 3). Be sure all burner control valves on the grill are turned "OFF". To connect hose and regulator to cylinder turn coupling nut clockwise as shown in diagram below (Fig. 19). (To remove the quick connect coupling nut, turn counter clockwise). Your MHP Grill comes with a Type I connector, also known as a "Quick Connect Valve" connection. It has a large plastic (coupling nut) that screws onto the propane tank gas outlet. **Note: Your MHP Grill does not come with a propane tank. Therefore, be sure the tank you purchase has this type of hook-up. Also, the cylinder you use must be equipped with a listed overfilling protection device. This can be identified by the triangular hand wheel. (See diagram below and page 5 of these instructions).**

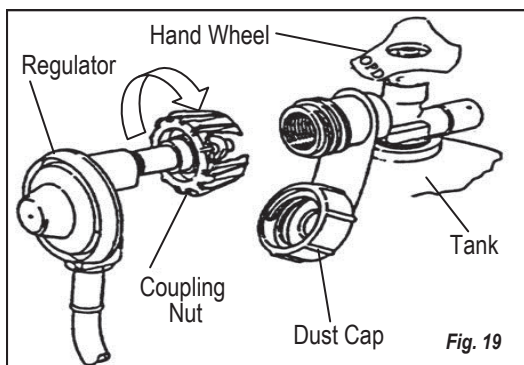

## REMOVAL OF THE LP CYLINDER

1. Close the LP tank valve.
2. Unscrew the QCC-1 plastic nut BY HAND COUNTER-CLOCKWISE (to the left).
3. Raise the tank locking bar
4. Lift cylinder off.

**WARNING:** If you exchange your LP cylinder, make sure you get a similar tank in return.

**WARNING:** Your exchanged LP cylinder must be equipped with a QCC-1 or type-1 valve and an OPD (Overfilling Prevention Device). Other LP cylinders may not be compatible with your grill connection.

## LP-GAS CYLINDER FILLING & HANDLING

A qualified attendant, who fills the cylinder by weight, should fill your LP cylinder at an authorized LP gas dealer. Improper filling is dangerous.

When transporting the LP cylinder be sure the plastic dust cover is in place over the valve. This keeps the valve threads free of dirt.

Do not handle the cylinder roughly.

Do not apply heat directly to the cylinder.

## LP-GAS CYLINDER FILLING & HANDLING (Continued)

- Air must be removed from a new LP cylinder before the initial filling. Your LP dealer is equipped to do this.
- The cylinder supply system must be arranged for vapor withdrawal
- Always keep and store cylinders in an upright, secure position.
- Use this grill outdoors in a well-ventilated area. Do not use in a garage, building, or any other enclosed area.
- Storage of an outdoor cooking gas appliance indoors is permissible only the cylinder is disconnected and removed from the outdoor cooking gas appliance.
- If the outdoor cooking appliance is not in use, the gas must be turned off at the supply cylinder.
- Cylinders must be stored outdoors out of reach of children and must not be stored in a building, garage or any other enclosed area.

## LP GAS CYLINDERS SAFE HANDLING TIPS

- Liquid propane (LP) gas is a petroleum product as are gasoline and natural gas. LP gas is a gas at regular temperatures and pressures. Under moderate pressure, inside a cylinder, LP gas is a liquid. As the pressure is released, the liquid readily vaporizes and becomes gas.
- LP gas has an odor similar to natural gas. Be aware of this odor.
- LP gas is heavier than air. Leaking gas collects in low areas and prevents dispersion.
- To fill, take the LP cylinder to your local authorized LP dealer, or look up "gas-propane" in the yellow pages to find authorized dealers.
- A new LP cylinder must be purged before the first filling. Your LP dealer is equipped to do this.
- An LP cylinder must be transported, installed and stored in an upright position.
- LP cylinders should not be handled roughly.
- Never store or transport an LP cylinder where the temperatures can reach 125 degrees. Never leave an LP cylinder in a car on a hot day.
- Always close the LP cylinder valve before disconnecting the tank or any other gas fitting.
- Always close the LP Cylinder valve after using grill.
- Do not use a damaged LP cylinder. Dented, rusty or a damaged LP cylinder valve may be hazardous and should be replaced with a new one immediately.



- **Never fill the LP cylinder beyond 80% full.**
- **Do not store a spare LP gas cylinder under or near the grill.**

**If this information is not followed exactly, a fire causing death or serious injury may occur.**

# Leak Testing & Lighting

## Leak Testing

- ⚠ LEAK TEST ALL GAS CONNECTIONS BEFORE USING YOUR GRILL.
- ⚠ DO NOT SMOKE WHILE LEAK TESTING.
- ⚠ DO NOT LEAK TEST WITH A MATCH OR OPEN FLAME.
- ⚠ DO NOT USE A GRILL THAT IS LEAKING GAS.
- ⚠ YOU SHOULD TEST FOR GAS LEAKS EVERY TIME YOU DISCONNECT AND RECONNECT A GAS FITTING.
- ⚠ PERFORM A LEAK TEST EVEN IF YOUR GRILL WAS DEALER OR STORE ASSEMBLED.
- ⚠ DO NOT IGNITE BURNERS WHEN LEAK TESTING.

### LEAK TESTING

1. For LP models, leak test with a full propane cylinder.
2. For systems other than self-contained LP cylinders:
  - A. The grill and its individual shut-off valve must be disconnected from the gas supply piping systems during any pressure testing of that system at test pressures in excess of 1/2 psi (3.5 kPa).
  - B. The grill must be isolated from the gas supply piping system by closing its own manual shut off valve during any pressure testing of the gas supply piping system at pressures equal to or less than 1/2 psi (3.5 kPa).
1. Grill burner control valves should be turned off and the gas turned on at source.
2. Apply soap solution to all gas connections.  
**To make soap solution, mix together equal amounts of liquid detergent and water.**
3. Soap bubbles will appear if there is a leak.
4. Tighten the connection to make proper seal. And recheck for soap bubbles.

⚠ If you cannot stop a gas leak by tightening, turn gas supply off. Take leaking joint apart, clean it, reconnect and test again. If leak persists, contact the dealer or gas utility.

⚠ A gas system **MUST** be tested yearly, or whenever the LP cylinder or any other gas system part is replaced.

## Lighting Your Grill

- ⚠ ALWAYS OPEN GRILL BEFORE LIGHTING THE BURNER.
- ⚠ DO NOT LEAN OVER AN OPEN GRILL. KEEP YOUR HEAD AND BODY AT LEAST ONE FOOT AWAY WHEN LIGHTING THE GRILL.
- ⚠ IF BURNER DOES NOT LIGHT, IMMEDIATELY TURN BURNER CONTROL KNOBS TO OFF. WAIT FIVE MINUTES TO LET GAS CLEAR BEFORE YOU TRY LIGHTING AGAIN.

### LIGHTING

1. Open Lid. Examine the interior to be sure it appears normal.
2. Turn burner control knobs to OFF position.
3. Turn gas ON at LP tank or supply. **Wait 5 seconds for regulator to set itself.**
4. Turn either burner control knob to HIGH and rotate the ignitor knob CLOCKWISE several times. One half of the burner should light. Turn the other burner control knob to HIGH and the other half of the burner will light automatically.
5. Check that the burner is lit by looking through the match light hole on the lower right hand side. The burner flame should be a hard blue cone with a minimum amount of yellow flame, although some yellow dust flicks may occur.

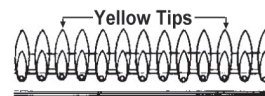

6. Close the grill lid and pre-heat the grill for five to ten minutes before cooking.

**WARNING:** If burner fails to light, turn control knobs OFF and wait five minutes for gas to clear and try lighting procedure again.

**To light burner manually,** use a paper book match or other hand held ignitor. Insert match through lower right side match hole. Turn on the **RIGHT** burner control knob to the high setting. Light burner.

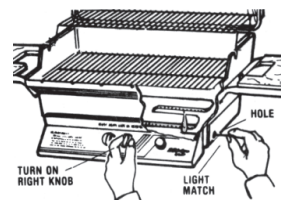

**To Extinguish your grill:** Turn each burner control knob to OFF position. Turn gas supply OFF at the source.

## Annual Maintenance

After a period of nonuse or to keep your grill in top operating condition, you should perform the following maintenance procedures to keep the grill ready for instant use and for your safety.

- Do not obstruct the flow of combustion and ventilation air.
- Clean inside the grill head. Remove the burner/venturi assembly and cover the valve orifices with a piece of aluminum foil to keep out dirt. Brush inside bottom and sides with a stiff wire brush to remove built-up grease and debris. **Be careful not to damage the Ignitor or Collector Box.**
- Test the Ignitor for a good spark. (See Rotary Spark Ignitor System in the General Maintenance section.)
- The stainless steel burner may be brushed lightly with a stiff laundry brush. Any clogged flame holes may be opened using a thin wire. Use the supplied venturi cleaning brush or a bottle brush, pipe cleaner to clean out the venturis. (See Flashback in General Maintenance.)
- Clean the Control Panel, Side Shelf Supports, Lid Handle Spacers, Lower Cart Frame, Posts with a mild detergent soap and warm water solution. For the Optimum Console use a mild detergent soap and water, Windex or a quality stainless steel cleaner such as MHP's Stainless Steel Cleaner (Part #SSC) to clean the column and grill lid facing. **Do Not Use cleaning agents such as bleach, powdered cleansers, steel wool pads or caustic solutions like oven cleaners because they will damage the surfaces.**
- Porcelain cooking grids should be cleaned by first pre-heating the grill on high for ten minutes, lid closed. Then with a brass bristled grill brush clean off the debris. Do Not wash the porcelain grates in a sink or dishwasher. It may ultimately cause the porcelain to chip.
- Occasional white oxidation on the exterior of your grill head and lid may be washed off with mild soap and warm water.
- Severe weathering of the grill head and lid can be remedied by lightly sanding or rubbing with steel wool. Then it can be recoated with a high quality heat resistant paint similar to MHP's BF-1 Paint, available in spray cans from your dealer.
- Inspect the hose and gas fittings. Remember to leak check every time you disconnect and reconnect a gas fitting.
- Keep the ventilation openings of the LP cylinder enclosure free and clear from debris.



**Warning:** Check the hose before each use of the grill for nicks, cracking, abrasions or cuts. If the hose is found to be damaged in any way, do not use the grill. Replace using only **MHP** authorized replacement hose.

## Maintenance

### General Maintenance

#### Flashback

In some areas of the country, spiders and other insects build nests, lay eggs and spin webs in the grill's venturi tube or valve orifice. This obstructs the full flow of gas to the burner. Some gas backs up resulting in a "Flashback" - a fire in the venturi behind the control panel which could cause serious bodily injury or damage to your grill. (Fig. 20)

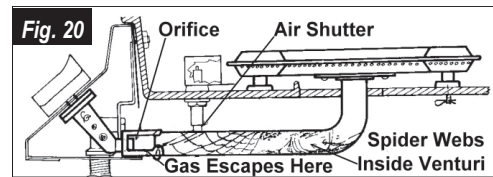

To remove spider webs and/or other obstructions, you must clean out the venturis. This should be done routinely if the grill has sat idle for extended periods. Also, if you live in an area where spiders are plentiful, you should clean the venturis often, especially in the fall when there is an increase in egg sack production.

To clean, be sure the grill is cold. Open lid and remove the cooking grids, the briquettes and the briquette grate.

Remove the burner clip holding the burner in place. (See Fig. 21) Lift burner and venturi assembly out. With supplied cleaning brush, a pipe cleaner or a flexible wire, clean out the venturi tube. Remove hex head orifice with a 3/8" wrench. Clean Orifice hole and inner part of the valve with a toothpick. Be careful not to enlarge the orifice hole.

Check orifice receptacle in valve body.

When finished cleaning reassemble the complete unit.

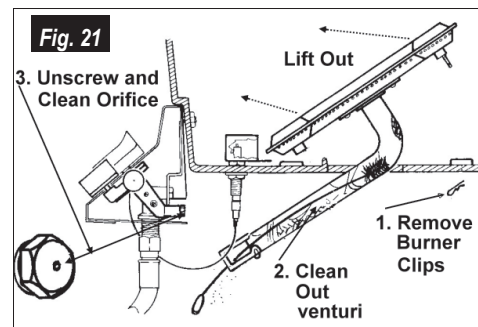

# Maintenance

## Rotary Spark Ignitor System

If you experience an occasional “No-spark-No light” condition here’s a check list to troubleshoot the problem.

**Inspection.** WITH GAS OFF, position a mirror in front of the collector box and rotate the ignitor knob several times. Observe the condition of the spark. (Low light conditions are the best for seeing the spark.)

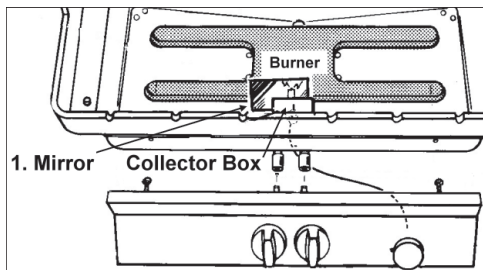

**A. If there’s a good spark**, but the grill won’t light, gas may not be flowing to the burner and into the collector box. The gas orifice or the venturi tube may be blocked. To clean, follow “Flashback” instructions.

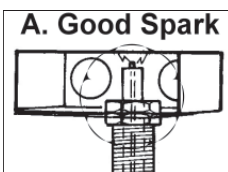

**B. If a weak spark arcs down around the ceramic insulator**, the insulator should be cleaned. The insulator has a coating of grease or it is wet. Use an old tooth brush to break up the conductive electric path.

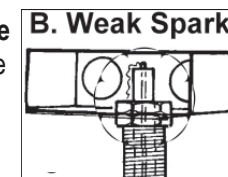

**2. If there is no spark in the collector box.**

**A. Check the wire connections** at the ignitor and electrode under the grill. Lubricating (use WD-40 or equivalent) the star wheel and tension spring of the ignitor will help connection contacts and improve operation.

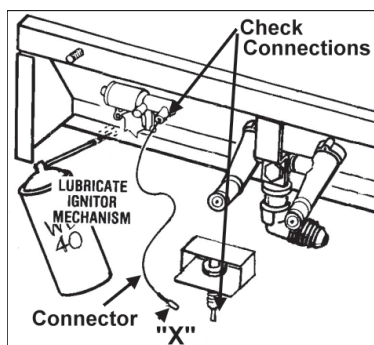

**B. Check spark.** Pull the connector wire from the collector box (see “X” Fig. 22). Bring wire to bottom or top of control panel, hold about 1/8" away and operate the ignitor. Check for spark. If there is **no spark** replace the Rotary Ignitor. If there is **a spark** the Rotary Ignitor is OK, but the Collector Box/Electrode assembly should be replaced (the ceramic insulator could be cracked).

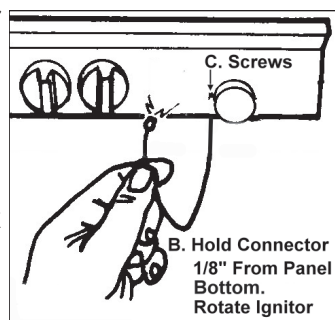

## General Maintenance

**C. Check Knob**, confirm quality of the electrical ground at the Rotary Ignitor. Remove the knob, loosen and retighten the mounting screws.

## Electrode Replacement or Adjustment

The electrode inside the collector box is pre-set for optimum spark. The tip is 1/8" from inside surface of the collector box. To replace, remove the collector box by loosening the large nut from the bottom of the grill. Check the gap of the new part before installing. Loosening and tighten the two jam nuts will move the electrode tip, set at 1/8".

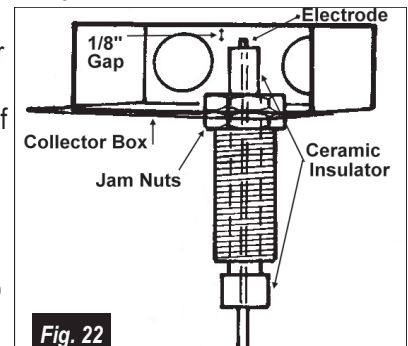

## Flare-Ups

Expect and encourage a moderate amount of flare-up to enhance flavor. To control excessive flare-ups - trim excess fat before cooking, lower the heat setting, move meat to other side of grill if possible, cook with lid down.

**For immediate control of flare-ups, throw a small amount of baking soda directly on the briquettes and lower heat setting. Do not douse flare-ups with water, this only worsens the flame.**

## Stainless Steel Cleaning

**Before Cleaning, determine which way the “grain” of the metal runs and always clean with the grain. NEVER USE STEEL WOOL PADS TO CLEAN STAINLESS STEEL.**

1. Routine cleaning is done with a warm soapy water applied with a sponge or soft cloth. Always rinse with clean hot water and wipe dry with a soft cloth. Glass cleaners like Windex also works well.
2. Stubborn stains can be removed with a mild non-scratching abrasive household powder. Add a small amount of vinegar to the scouring powder to increase its potency.
3. Commercial stainless steel cleaners and polishers also work well, such as MHP’s Stainless Steel Cleaner (Part #SSC).  
**Note: Over time the stainless steel will turn a mild gold patina from the grill’s heat. This is normal.**

# Cooking Techniques

More Versatile than your kitchen oven...your MHP Gas Grill roasts, sears, broils, spit-roast, bakes, steams and smokes. The eating enjoyment of each cooking technique will result in a distinctive flavor for entertaining friends or a welcomed treat for a family meal.



**Direct**—For grilling/searing steaks, chops, burgers, frankfurters, sausages, fish fillets, chicken parts or shish-ka-bobs. Your MHP Gas Grill is designed to cook with the lid closed, except for quick searing or more of a char flavor. Close lid to finish grilling, retaining natural juices, moisture and preventing flare-ups.

**Indirect (use one side of burner)** - For roasts, ribs, ham, whole chicken, turkey, game or whole fish. Using the indirect heat method, turn on one side of burner, then place food on the cooking grid over the side of burner that's not lit.

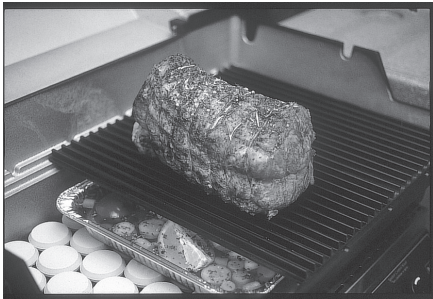
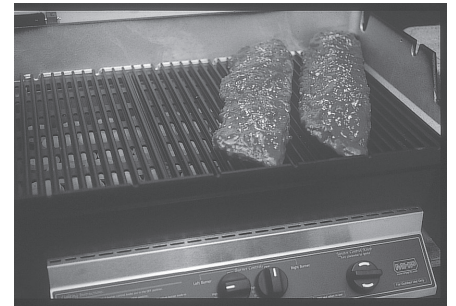

**Indirect (use of water pan)** - An aluminum foil pan is centered on the briquettes to moderate the temperature and to add moisture and flavor. Fill the pan with water or other ingredients, (add to water; wine, apple juice, orange juice, herbs, spices, etc). The cooking juices from the food drops into the water pan creating a savory water vapor from which the foods absorbs flavor and moisture.

**Pan Roasting**—For large cuts of meat, pot roast, turkey, whole chickens, duckling, aluminum foil drip pan or shallow metal baking/roasting pan on top of cooking grid. For extra flavor, add your favorite vegetables or some wine or fruit juice or garlic, onions to the drip pan. Use liquid to baste or gravy.

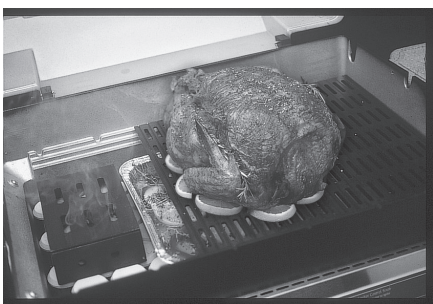

**Smoke (addition of wood chips or chunks)** - Ordinary meat, whole fish, poultry and game becomes a taste sensation when smoked. Using the water pan technique and your favorite wood soaked in water for several hours or overnight. Place chips in the convenient MHP reusable smoke box or wrap in aluminum foil, poke a couple of small holes in the foil pack. Place holes side up directly on briquettes along side of water pan.

**Rotisserie**—Poultry, lamb, beef and pork tastes more of themselves when spit-roasted. Meat is rotated over the heat keeping it constantly bathed in its own juices, insuring that all sides become done at one time. A drip pan can be used to collect the drippings for basting or gravy.

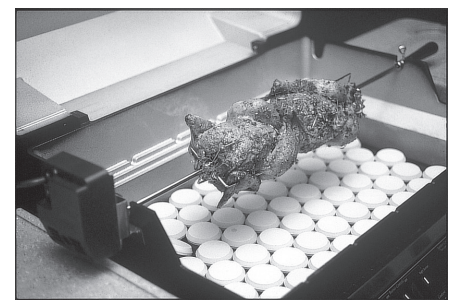

# Troubleshooting

Problem	Cause	Check
Yellow or orange flame and the smell of gas.	<ol style="list-style-type: none"> <li>1. Blockage in the venturi tube or orifice.</li> <li>2. Orifice not seated properly in the venturi Tube.</li> <li>3. Bent or kinked hose.</li> </ol>	<ol style="list-style-type: none"> <li>1. Clean venturi (See section "Annual Maintenance").</li> <li>2. Orifice must fit into venturi tube at least ¼" to ½"</li> <li>3. Check gas supply line. Also, check all connections.</li> </ol>
Burner does not light or flame is low in HIGH position.	<ol style="list-style-type: none"> <li>1. Could be a kink in the gas supply line.</li> <li>2. LP tank could be low or empty.</li> <li>3. LP regulator excess flow feature has been activated.</li> </ol>	<ol style="list-style-type: none"> <li>1. Straighten</li> <li>2. Refill LP cylinder</li> <li>3. Turn grill control knobs off, close LP tank valve and reopen valve slowly. Wait 5-seconds before turning on grill valves</li> </ol>
Erratic flame pattern from burner or flame is low when burner control knob set at HIGH or flames do not run the whole length of burner.	Dirty burner	Clean burner holes with a small pin. Be careful not to enlarge holes
Constant flare-ups	<ol style="list-style-type: none"> <li>1. Grill too cold before start of cooking.</li> <li>2. Cooking grate or briquettes may be heavily coated with burned-on grease.</li> <li>3. Fatty foods.</li> <li>4. Heat setting too high.</li> <li>5. Briquettes laid out improperly allowing grease to hit flame.</li> </ol>	<ol style="list-style-type: none"> <li>1. You should always pre-heat grill for 5 to 10 minutes before cooking.</li> <li>2. Clean cooking grate. Clean and turn over briquettes.</li> <li>3. Trim excessive fat from fatty meats.</li> <li>4. Lower heat setting.</li> <li>5. Layout briquettes according to instructions on page 18.</li> </ol>
Briquettes have turned black.	Dripping grease has Burned-onto briquettes.	Turn briquettes over. Over time black side of briquettes will self clean.
Food sticks to cooking grid.	<ol style="list-style-type: none"> <li>1. Cooking grid is probably too hot.</li> <li>2. Food being turned before sear lines are produced.</li> </ol>	<ol style="list-style-type: none"> <li>1. Lower heat setting. Grids, especially SearMagic transfer heat quickly. You'll need to experiment with heat setting to get the best results. Or use a non-stick cooking spray.</li> <li>2. Time food to turn over only once.</li> </ol>
Flame blows out.	During periods of high wind and sometimes while cooking on a low setting, flame may be extinguished.	<ol style="list-style-type: none"> <li>1. On cart, simply turn away from wind.</li> <li>2. Increase the heat setting.</li> </ol>
Oxidation Graying of grill head.	Due to extreme cooking temperatures and severe weather conditions the grill body may bleed through the paint and cause white spotting (Oxidation).	Use a wire brush, sandpaper and wash with mild soap to remove flaking paint and grease. Repaint with high quality heat resistant paint similar to MHP's BF-1 Paint.
Grill does not get hot.	<ol style="list-style-type: none"> <li>1. See low flame above.</li> <li>2. On natural gas, inadequate pressure at grill.</li> <li>3. Incorrect orifice.</li> </ol>	<ol style="list-style-type: none"> <li>1. See low flame above.</li> <li>2. Check pressure. Should be at or near 7" water column.</li> <li>3. Check orifice size.</li> </ol>

**CAUTION: If problems can not be corrected using these methods, contact your local MHP dealer for assistance.**

# AMC Grill Parts Information

AMCT		
Quantity	Item Code	Description
1	GGTECL	Left End Lid Casting
1	GGTECR	Right End Lid Casting
1	GGTSI	Stainless Steel Lid Insert
1	GGTBC	Bottom Grill Head Casting
1	GGDLB	Burner
67	GGBQ3R	Porcelain Briquettes
2	GGSSGRIDAMC	Stainless Cooking Grid
1	GGCP	Control Panel
2	GGCPB	Control Panel Brackets
1	GGDEF	Control Panel Heat Deflector Shield
1	GGDV13	Burner Venturi Tubes
1	GGGRATESS	Briquette Grate
1	GGIB	Ignitor Collector Box
1	GGK9	Igintor Knob
2	GGK10	Burner Control Knobs
2	GGLPP	Lid Pivot Pins
1	GGTSH	Sta-Kool Handle
2	GGSSDDBL	Left Side Shelf Bracket
2	GGSSDDBR	Right Side Shelf Bracket
1	GGTG4	Stainless Steel Temperature Gauge
2	GGWCIDD	Side Shelves
1	GGTS	Stainless Steel Warming Rack
1	GGVLV32	<b>Natural</b> Gas Valve
1	ASCPL1	12' Hose With Quick Disconnect <i>(Included W/Natural Gas Model)</i>
1	GGVLV28	<b>Propane</b> Gas Valve
1	HR4B	Hose and Regulator <i>(Included W/Propane Model)</i>
4	KKWL3	Casters <i>(Included with AMCJSS Models)</i>
1	PFBASE	Column Base <i>(Included with AMCWSS Models)</i>
1	PFCFT	Column Front Panel <i>(Included with AMCWSS Models)</i>
2	PFCSD	Column Side Panel <i>(Included with AMCWSS Models)</i>
1	PFSUP	Column Support Shelf <i>(Included with AMCWSS Models)</i>
1	MPP	Post For In-Ground Installation <i>(Included with AMCWMP Models)</i>
1	MPB	Post and Deck/Patio Base <i>(Included with AMCWMP Models)</i>

AMCW		
Quantity	Item Code	Description
1	GGTC3	Left End Lid Casting
1	GGTBC	Bottom Grill Head Casting
1	GGDLB	Burner
67	GGBQ3R	Porcelain Briquettes
2	GGSSGRIDAMC	Stainless Cooking Grid
1	GGCP	Control Panel
2	GGCPB	Control Panel Brackets
1	GGDEF	Control Panel Heat Deflector Shield
1	GGDV13	Burner Venturi Tubes
1	GGGRATESS	Briquette Grate
1	GGIB	Ignitor Collector Box
1	GGK9	Igintor Knob
2	GGK10	Burner Control Knobs
2	GGLPP	Lid Pivot Pins
1	GGSH	Sta-Kool Handle
2	GGSHC	Handle End Cap
2	GGSSDDBL	Left Side Shelf Bracket
2	GGSSDDBR	Right Side Shelf Bracket
1	GGTG4	Stainless Steel Temperature Gauge
2	GGWCIDD	Side Shelves
1	GGTS	Stainless Steel Warming Rack
1	GGVLV32	<b>Natural</b> Gas Valve
1	ASCPL1	12' Hose With Quick Disconnect <i>(Included W/Natural Gas Model)</i>
1	GGVLV28	<b>Propane</b> Gas Valve
1	HR4B	Hose and Regulator <i>(Included W/Propane Model)</i>
4	KKWL3	Casters <i>(Included with AMCJSS Models)</i>
1	PFBASE	Column Base <i>(Included with AMCWSS Models)</i>
1	PFCFT	Column Front Panel <i>(Included with AMCWSS Models)</i>
2	PFCSD	Column Side Panel <i>(Included with AMCWSS Models)</i>
1	PFSUP	Column Support Shelf <i>(Included with AMCWSS Models)</i>
1	MPP	Post For In-Ground Installation <i>(Included with AMCWMP Models)</i>
1	MPB	Post and Deck/Patio Base <i>(Included with AMCWMP Models)</i>

AMCJ		
Quantity	Item Code	Description
1	HHTC3	Grill Lid Casting
1	HHBC3	Bottom Grill Head Casting
1	HHDSB	Burner
53	GGBQ3R	Porcelain Briquettes
2	HHSSGRIDAMC	Stainless Cooking Grid
1	HHCP	Control Panel
2	GGCPB	Control Panel Brackets
1	HHDEF	Control Panel Heat Deflector Shield
1	GGDV13	Burner Venturi Tubes
1	HHGRATESS	Briquette Grate
1	GGIB	Ignitor Collector Box
1	GGK9	Igintor Knob
2	GGK10	Burner Control Knobs
2	GGLPP	Lid Pivot Pins
1	HSH	Sta-Kool Handle
2	GGSHC	Handle End Cap
1	GGSSDDBL	Left Side Shelf Bracket
1	GGSSDDBR	Right Side Shelf Bracket
1	GGTG4	Stainless Steel Temperature Gauge
1	GGWCIDD	Side Shelf
1	HHSSTS	Stainless Steel Warming Rack
1	HHVLV32	<b>Natural</b> Gas Valve
1	ASCPL1	12' Hose With Quick Disconnect <i>(Included W/Natural Gas Model)</i>
1	HHVLV28	<b>Propane</b> Gas Valve
1	HR4B	Hose and Regulator <i>(Included W/Propane Model)</i>
4	KKWL3	Casters <i>(Included with AMCJSS Models)</i>
1	PFBASE	Column Base <i>(Included with AMCJSS Models)</i>
1	PFCFT	Column Front Panel <i>(Included with AMCJSS Models)</i>
2	PFCSD	Column Side Panel <i>(Included with AMCJSS Models)</i>
1	PFSUP	Column Support Shelf <i>(Included with AMCJSS Models)</i>
1	MPP	Post For In-Ground Installation <i>(Included with AMCJMP Models)</i>
1	MPB	Post and Deck/Patio Base <i>(Included with AMCJMP Models)</i>

# Outdoor Creations From MHP™

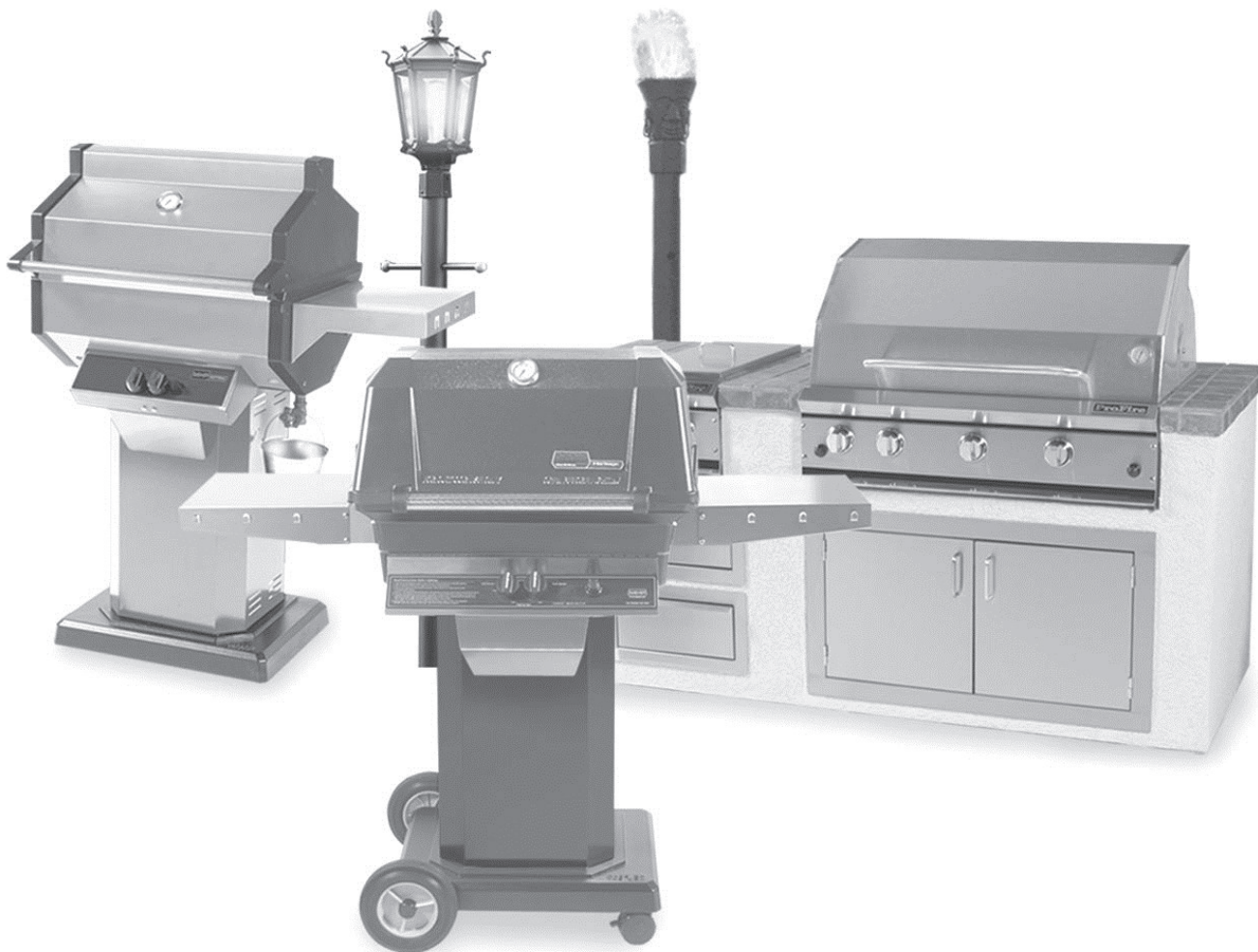

## Modern Home Products Corporation

150 South Ram Road, Antioch, Illinois 60002  
Phone: 1-888-647-4745 • 847-395-6556  
Fax: 1-800-637-2918 • 847-395-9121  
E-Mail: [customerservice@mhpgrills.com](mailto:customerservice@mhpgrills.com)  
Web Site: [www.mhpgrills.com](http://www.mhpgrills.com)

*MHP IS YOUR COMPLETE SOURCE FOR GRILLS, LAMPS, PARTS & ACCESSORIES*

**Modern Home Products Corporation**

**MHP**  
OUTDOOR GRILLS

**ProFire® Grills**  
*Perfection by Design*

**PHOENIX**  
GRILLS

**BRAVO**

**MHP**  
GRILL PARTS

*Everglow*  
GAS LAMPS & TORCHES

*Celebrating 60 Years in Business*

MHP Grills are covered by U.S. Patent Nos. D 326,207 and D 359,877; Burners by U.S. Patent Nos. 4,267,506; 4,373,505; 4,267,816; 4,488,534  
MHP configuration, Chef's Choice, BBQer's Choice, SearMagic, Flavor Master, New Phoenix, ProFire, Duro-Cart and Infra-Roast are trademarks of Modern Home Products Corporation.

©2014 Modern Home Products Corporation.

(6-18)

Printed In U.S.A.