

This Owner's Manual is provided and hosted by [Appliance Factory Parts](#).



# TRION SS-200 Owner's Manual

[Shop genuine replacement parts for TRION SS-200](#)



[Find Your TRION Humidifier Parts - Select From 27 Models](#)

----- Manual continues below -----



READ & SAVE THESE INSTRUCTIONS

## Herrmidisteam SS

Installation, Operation, & Maintenance

## TABLE OF CONTENTS

I. Warranty .....	3
II. General Warnings & Installer Responsibility .....	3
III. Description of Units.....	4
IV. Dimensions, Capacities, & Weights.....	4
V. Unit Mounting.....	5
VI. Plumbing .....	5
VII. Drain Piping.....	6
VIII. Steam Distribution Mounting .....	6
IX. Electrical & Controls .....	7
X. Startup & Operations .....	12
XI. Recommended Maintenance .....	13
XII. Troubleshooting.....	14
XIII. Parts List .....	15
XIV. Options & Accessories .....	15

## I. WARRANTY

### Limited 2-Year Warranty

Seller warrants the equipment of its manufacturing to be free from defects in workmanship and material for a period of 24 months after shipment or 24 months after initial commissioning, whichever occurs first. This warranty is limited, however, to the repair or replacement of defective equipment, which is returned, freight prepaid, to Seller's factory.

This limited warranty does not apply to any part or component that is damaged in transit or when handling, has been subject to misuse, negligence or accident, has not been installed, operated or serviced according to Seller's instructions, or has been operated beyond the factory-rated capacity or has been altered in any way.

Seller's liability is limited to replacement of defective parts or components and does not include any cost of labor (including, but not limited to, labor required to remove and/or reinstall any defective part) other than TRION/HERRMIDIFIER factory labor.

TRION/HERRMIDIFIER shall not be responsible for loss of use of any product, loss of time, inconvenience, or damage to other equipment, or any other indirect or consequential damage with respect to property whether as a result of breach of warranty, neglect, or otherwise.

THE WARRANTIES AND LIABILITIES SET FORTH ARE IN LIEU OF ALL OTHER WARRANTIES AND LIABILITIES, EXPRESSED OR IMPLIED, IN LAW OR IN FACT, INCLUDING IMPLIED WARRANTIES OF MERCHANTABILITY AND FITNESS FOR PARTICULAR PURPOSE.

The foregoing shall constitute the total liability of seller in the case of defective performance of all or any of the equipment or services provided to Buyer. Buyer agrees to accept and hereby accepts the foregoing as the sole and exclusive remedy for any breach or alleged breach of warranty by Seller.

## II. GENERAL WARNINGS & INSTALLER RESPONSIBILITY

### ATTENTION

READ THIS MANUAL, FACTORY INSTALLED OPTIONS MANUAL, UNIT SUBMITTAL DATA SHEETS AND ALL LABELS ATTACHED TO THE UNIT CAREFULLY BEFORE ATTEMPTING TO INSTALL, OPERATE, OR SERVICE THESE UNITS. CHECK DATA PLATES FOR ELECTRICAL SPECIFICATIONS AND MAKE CERTAIN THAT THESE AGREE WITH THOSE AT THE POINT OF INSTALLATION.

### WARNING

IMPROPER INSTALLATION, ADJUSTMENT, ALTERATION, SERVICE, OR MAINTENANCE CAN CAUSE PROPERTY DAMAGE, INJURY, OR DEATH. THIS APPLIANCE MUST BE INSTALLED BY A LICENSED CONTRACTOR OR QUALIFIED SERVICE PERSONNEL. READ THESE INSTALLATION, OPERATING, AND MAINTENANCE INSTRUCTIONS THOROUGHLY BEFORE INSTALLING OR SERVICING THE UNIT.

### WARNING

INSTALL, OPERATE, AND MAINTAIN UNIT IN ACCORDANCE WITH MANUFACTURER'S INSTRUCTIONS TO AVOID ANY CIRCUMSTANCES THAT MAY CAUSE PERSONAL INJURY OR PROPERTY DAMAGE.

### DANGER OF ELECTRIC SHOCK

INSTALL, OPERATE AND MAINTAIN UNIT IN ACCORDANCE WITH MANUFACTURER'S INSTRUCTIONS TO AVOID ANY CIRCUMSTANCES THAT MAY CAUSE PERSONAL INJURY OR PROPERTY DAMAGE.

### DANGER OF WATER LEAKS

THE HUMIDIFIER AUTOMATICALLY AND CONSTANTLY FILLS/DRAINS CERTAIN QUANTITIES OF WATER. MALFUNCTIONS IN THE CONNECTIONS OR IN THE HUMIDIFIER MAY CAUSE LEAKS. A DRAIN PAN IS RECOMMENDED UNDER THE UNIT TO PROTECT PROPERTY FROM DAMAGE IN THE CASE OF WATER LEAKAGE OR SPILLAGE.

### DANGER OF BURNS

THE HUMIDIFIER CONTAINS HIGH TEMPERATURE COMPONENTS AND DELIVERS STEAM AT 100°C/212°F.

### Important

- The installation of the product must include an earth connection.
- The environmental and power supply conditions must conform to the values specified on the product rating labels.
- The product is designed exclusively to humidify rooms either directly or through distribution systems (ducts).
- Only qualified personnel who are aware of the necessary precautions and able to perform the required operations correctly may install, operate, or carry out technical service on the product.
- Only water with the characteristics indicated in this manual must be used for steam production.
- All operations on the product must be carried out according to the instructions provided in this manual and on the labels applied to the product. Any uses or modifications that are not authorized by the manufacturer are considered improper. Seller declines all liability for any such unauthorized use.
- Do not attempt to open the humidifier in ways other than those specified in the manual.
- Observe the standards in force in the place where the humidifier is installed.
- Keep the humidifier out of the reach of children and animals.
- Do not install and use the product near objects that may be damaged when in contact with water (or condensate). Seller declines all liability for direct or indirect damage following water leaks from the humidifier.
- Do not use corrosive chemicals, solvents, or aggressive detergents to clean the inside and outside parts of the humidifier, unless specifically indicated in the user manual.
- Do not drop, hit, or shake the humidifier, as the inside parts and the linings may be irreparably damaged.

# Installation, Operation, & Maintenance Manual

## III. DESCRIPTION OF UNITS

Herrmidisteam creates chemical free steam humidification by circulating boiler steam through a water immersed heat exchanger.

The Herrmidisteam includes models for use with any raw or DI/RO water applications. The tank and steam coil are constructed of stainless steel, and a skimmer system is provided to automatically drain floating water contaminants if raw water is used. Make up water is supplied through a solenoid valve, and water is drained automatically through a solenoid drain valve. Drain water temperature can be lowered by using the optionally installed drain tempering valve kit. The system is virtually maintenance free when used with DI/RO water due to the lack of significant minerals being precipitated out and left behind in the tank.

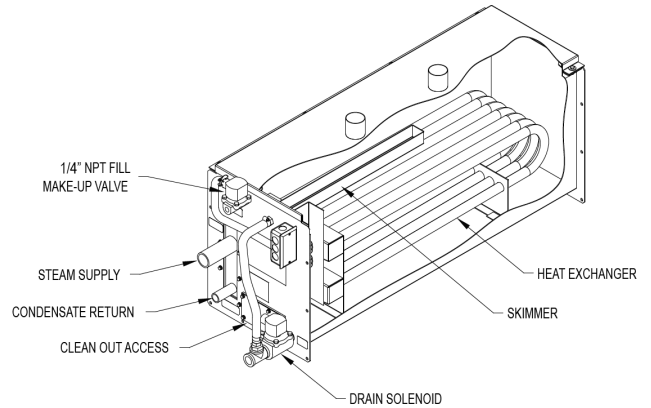

## IV. DIMENSIONS, CAPACITIES, & WEIGHTS

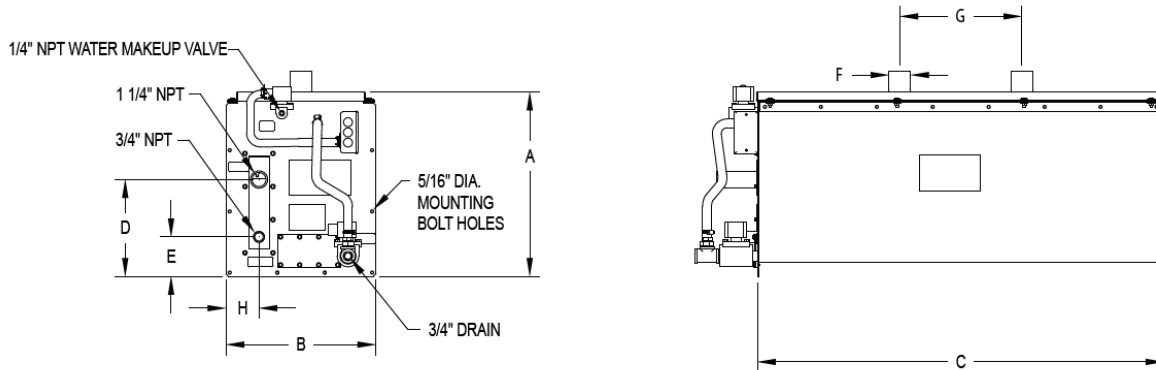

**Mechanical Dimensions**

Description	SS-200		SS-500		SS-800	
	in	mm	in	mm	in	mm
A Overall height	18.08	459.2	21.00	533.4	32.11	815.6
B Face width	14.75	374.7	25.00	635.0	25.00	635.0
C Face length	40.00	1016.0	40.00	1016.0	40.00	1016.0
D Distance from bottom to supply inlet	9.13	231.9	9.48	240.8	9.48	240.8
E Distance from bottom to return inlet	3.50	88.9	3.85	97.8	3.85	97.8
F Outlet connection OD	-	-	-	-	20.38	517.7
G Distance between outlets	-	-	-	-	14.76	374.9
H Distance from side to steam connections	3.25	82.6	12.25	311.2	12.25	311.2

**Unit Capacity vs. Inlet Pressure to Heat Exchanger**

Model	Steam Pressure (lbs/hr)							
	psi		kPa		psi		kPa	
	5	34	10	69	13	90	15	103
SS-200	55		120		165		200	
SS-500	65		210		310		400	
SS-800	185		375		540		760	

**Unit Weights**

Model	Operating Weight		Empty Weight	
	lbs	kg	lbs	kg
SS-200	330	152	125	57
SS-500	350	159	140	64
SS-800	950	431	320	145

## V. TYPICAL UNIT MOUNTING CONFIGURATIONS

Mounting Notes:

1. For the magnetic water level switch and the skimmer system to properly operate, the humidifier must be mounted level and plumb.
2. Access (12" to 18" minimum) for periodic removal of the top cover is recommended. In most cases, scale that forms on the heat exchanger continuously flakes off as it forms, and the loose scale settles to the bottom. A clean-out cover is provided for periodic removal of scale.

### 1. Floor Stand

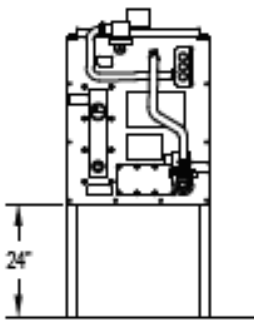

### 2. Ceiling Hanger

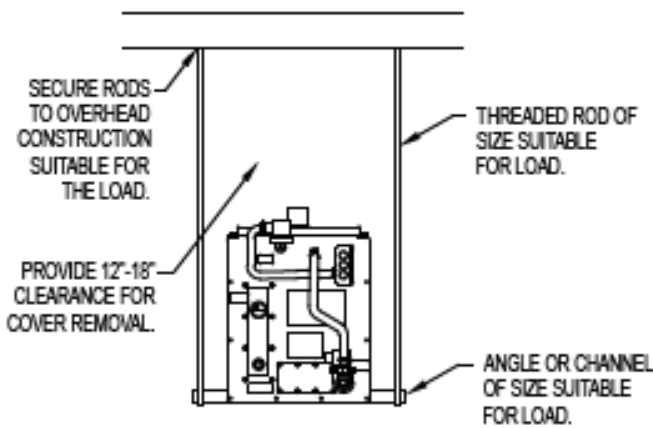

## VI. PLUMBING

The "Gravity Condensate Return" figure shows piping of the unit from the steam supply main with condensate returned to a vented gravity flow return system. Note the supply trap installed at the bottom of the branch rise feeding the steam valve of the unit. Failure to install this trap will cause water hammer, which could damage the heat exchanger.

The "Elevated Condensate Return" figure depicts the same supply configuration. However, the condensate return main is above the unit, and the condensate must be "lifted." Lifts in excess of six inches per PSI steam inlet pressure should not be attempted. Check valves downstream of both steam traps are necessary to avoid hammer and associated problems.

In both instances, the vacuum breakers are necessary to ensure condensate can drain from the heat exchanger when the steam valve closes.

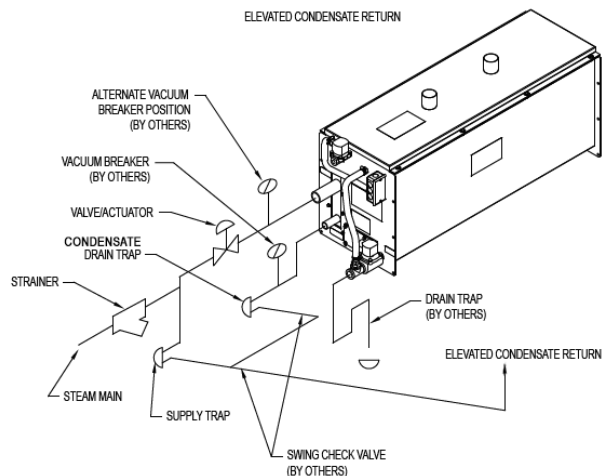
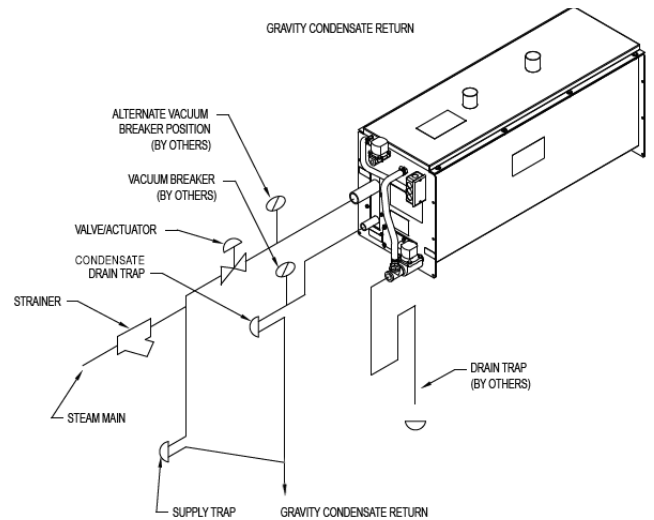

## VII. DRAIN PIPING

A drain line should be extended from the skimmer/drain connection to a sanitary waste. A water seal should be provided in the drain line of sufficient height to contain the pressure developed within the humidifier. Without this, steam will be forced through the drain line, which would be objectionable. The depth of the water seal must be sufficient to overcome the static pressure of the air handling system plus the pressure developed by the humidifier itself.

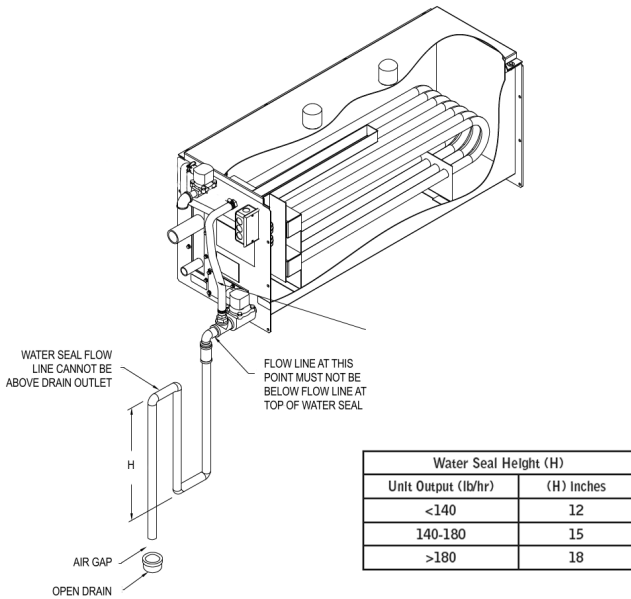

## VIII. STEAM DISTRIBUTOR MOUNTING

Each steam unit requires at least one outlet for steam via a duct distributor.

### Steam Distributor Pipes

TRION/HERRMIDIFIER supplies stainless steel duct distributor pipe(s) for use in injecting pure steam into ducts. Refer to Figures on this page for proper placement. A minimum of 3' clearance downstream is required for most applications. However, differing psychrometric conditions may require a greater or lesser steam absorption distance. Consult the factory if you have any questions or need to exchange your standard distribution system for a rapid absorption CS-Series Distribution system.

### Notes

- The rubber steam hose carries steam to the distributor pipe and condensate back to the unit. It must have an 8% (1" per foot) pitch back to the unit. Support the steam hose so it will maintain the proper pitch when in operation or at rest.
- If any low spots are in the steam line or the unit is mounted

higher than the distribution system, spitting may occur from the steam distribution pipes.

- Mount the unit as close to the distribution pipe as possible. Use Type L insulated copper pipe whenever the length of run exceeds 20 feet. Do not exceed a 30 foot run as the capacity of the unit will be decreased by as much as 15% and the increased static pressure could cause problems with the fill system.
- Internal duct insulation should be removed in the "bulk evaporation" zone (Consult factory representative).
- Steam holes in the distribution pipe are located 2" from mounting plate and designed for a maximum duct wall thickness of 1". Consult factory if special hole locations are required.
- Do not mount the standard distribution pipe in a vertical downflow or vertical position in a horizontal flow system. Special pipes are available, consult the factory.

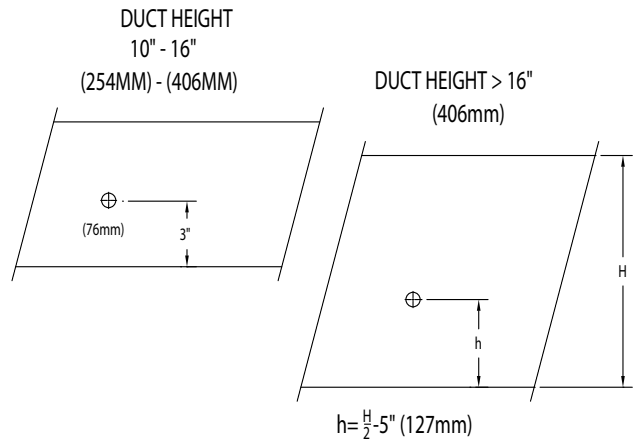

*Single Distributor Pipe*

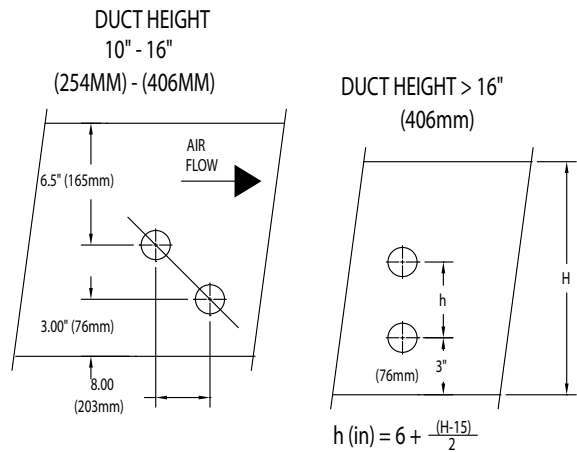

*Dual Distribution Pipes*

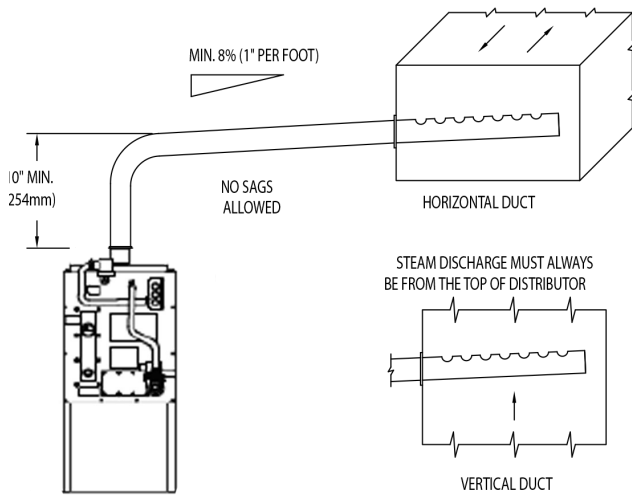

*Standard Duct Distribution*

## IX. ELECTRICAL & CONTROLS

The electrical supply is 120VAC. The control cabinet should be mounted in a location suitable for access and service. All wiring must be in accordance with all governing codes and the Herrmidisteam wiring diagram. The wiring between the control cabinet and the humidifier must be 105°C rated wire.

Please refer to the next section in this manual for information regarding electrical connections and information on the controller operation.

**Caution:** Only qualified technicians should perform installation and start-up procedures.

The Herrmidisteam humidifier is configured for proportional modulation control. This means that a proportional demand signal is supplied to the input, and the controller operates the output capacity to a level directly proportional to the input signal.

All external electrical control circuits are to be connected to the terminal strip located inside the control cabinet. Field wiring from a humidity controller to humidifier and between safety devices, such as high limit humidistat and air proving switches, should be 18 AWG stranded or 20 AWG solid wire minimum.

Wall devices should be mounted at a height similar to that of a typical thermostat and should be located in an area that will provide good representation of the overall space being humidified. Do not mount wall devices directly in the air stream of a supply grille.

Duct high limit devices should be mounted downstream of the steam distributors - far enough that under normal conditions in the air stream that the steam has been completely absorbed, typically 10 ft. The device should be located such

that it can sense humidified air as it approaches saturation. Do not mount in dead air spaces such as inside of corners.

Air proving switches should be mounted so that they sense airflow (or the absence of it). Wire the device so that it closes when airflow is present and will open when there is no airflow. The purpose of the device is to prove that airflow is present before steam is distributed into the duct.

The wiring diagram on the following pages indicate the field wired components and connection information.

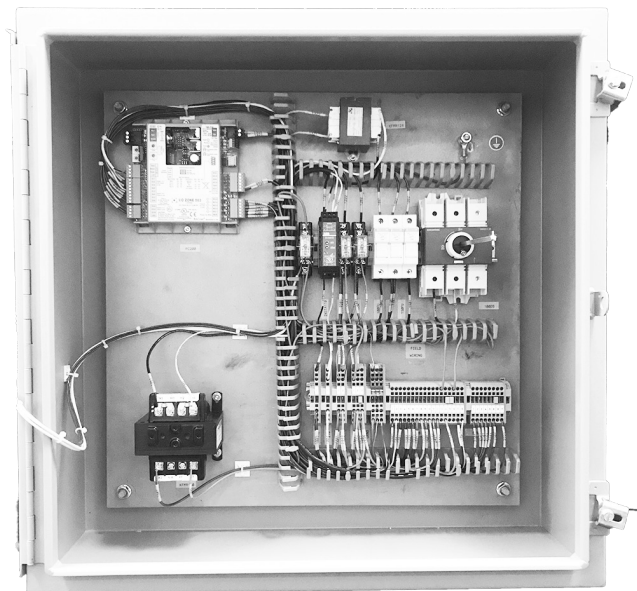



# Installation, Operation, & Maintenance Manual

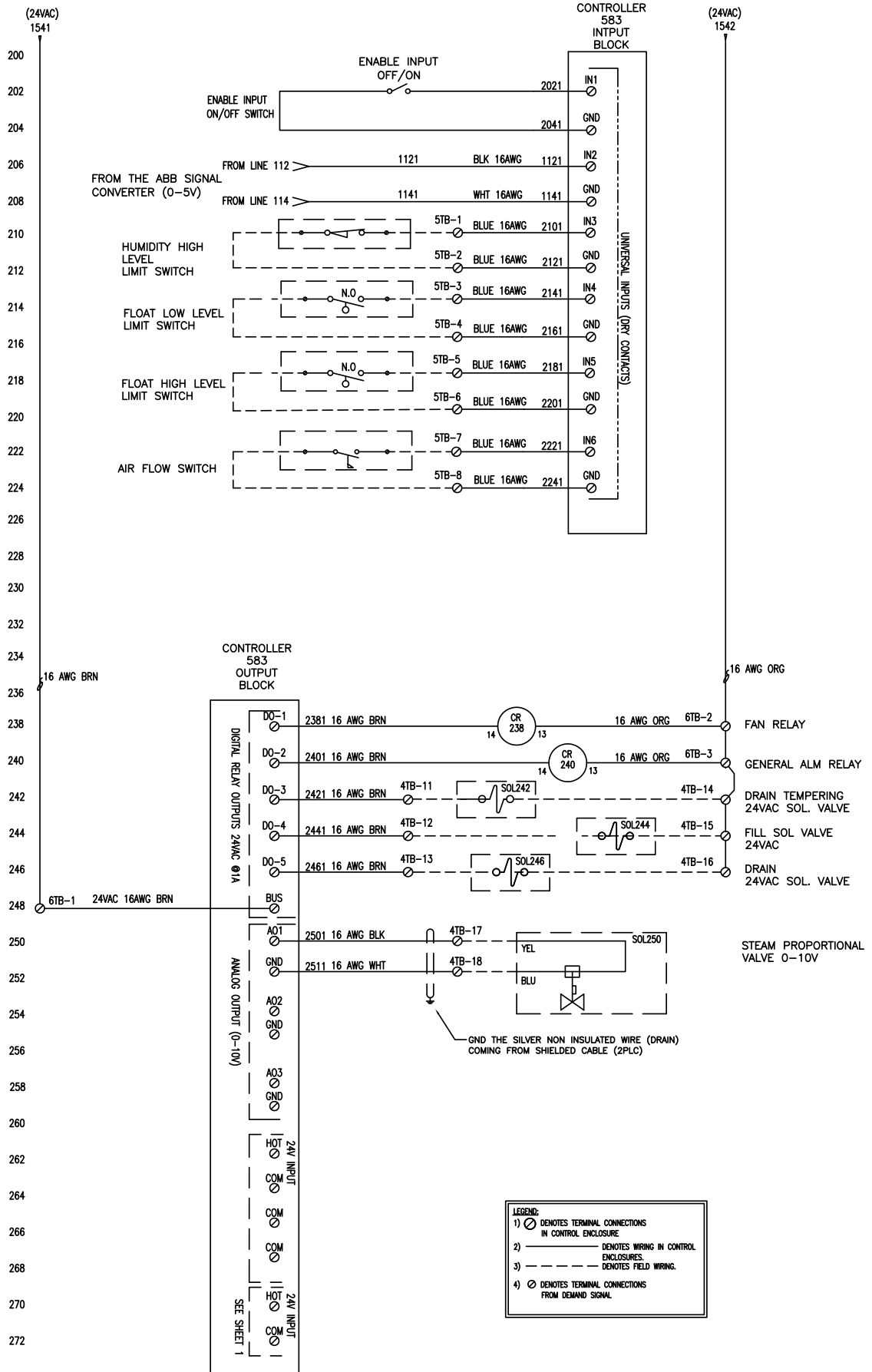

## Standby Screen

The Standby Screen displays the ON/OFF state of the control system. The top of the screen will display the digital calendar and real time clock that is setup by OEM or end user. It also shows the percentage of output being sent to a modulating steam valve. Touching anywhere in the Standby Screen will take you to the Home Screen. If there is no interfacing between the end user and the touchscreen after one minute, the display will automatically go to the Standby Screen.



## Home Screen

The Home Screen displays the control system status. In addition, it gives the end user privileges to the system Parameters, Status, Login, and Configuration screens.



## Parameter Screen

The Parameter Screen (password required) gives the end user access to change certain timing functions and system actions within the program. Below are brief descriptions of some of these functions and actions.

- Auto Drain Mode is an ON and OFF function, adjustable by the end user. The default is OFF. In the ON mode, the unit will drain periodically according to the values set up in the Drain Interval, Drain Time, Skim Time, and Drain Tempering parameters. (Note: De-ionized or reverse osmosis water application rarely require the ADM feature to be enabled, as the water contains very low dissolved solids.)
- Drain Interval is the interval at which the unit will initiate a timed drain. The end user can adjust the time in hourly increments. The range is 6 - 24 hours, with a default of 24 hours.
- Drain Time is the allotted time the drain valve will remain open during the drain mode. The end user can adjust

the time in increments of one minute. The range is 5 - 15 minutes with a default of five minutes.

- Skim Time is the amount of time the unit will continue filling to skim the surface of the water every time a fill cycle is activated. This feature may be set to zero by the end user if the system is operating with very clean water, such as de-ionized water. The end user can adjust the time in increments of one minute. The range is 0 - 10 minutes, with a default of 0 minutes. Low water pressure may require these settings to be increased so that the unit will skim.
- Drain Tempering, if applicable, is an ON or OFF function that will activate the fill valve anytime the drain valve is active. The default setting is OFF. The purpose is to help lower the drain water temperature by diluting the drain water (hot) with tempered water (cold). Water ensuing from the skimmer port on the tank is not tempered, so an external drain water tempering advice may be required. Please consult the factory for information about the Drain Tempering Reservoir (sold separately).
- Manual Drain allows the manual manipulation of the drain valve to empty the tank of water. Beware, the manual draining of the tank will not be tempered with cold water. Because this is an ON or OFF function, the valve will remain open unless turned OFF by the end user using the same means by which it was turned ON. **Note: The cycling of power to the controller will not reset the drain function.**

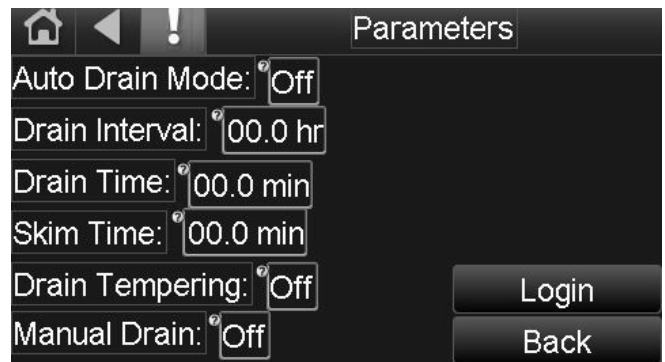

## Status Screen

The Status Screen contains a list of system inputs and outputs that may be monitored by the operator. The display shows the state and action of inputs and outputs. These read-only status bits and signal will display in the form of a numerical value or an ON/OFF state. Below is a list of these monitoring points.

- Input displays the 0-5Vdc scaled input based on 0-10Vdc input signal. This minimum and maximum input voltage is for the controller to process. This control signal can come from a BMS 0-10Vdc generated linear signal or a humidity transfer with a 0-10Vdc output signal.
- Output displays the percentage of output needed to the steam valve to meet a required setpoint.
- High Humidity Limit displays MADE if the high humidity setpoint has been reached or OFF if above the given setpoint.
- Air Proving Switch confirms whether the air is flowing by

displaying MADE for the presence of airflow or OFF for the absence of airflow.

- Upper Level Switch serves as an alarm for the Lower Level Fault Switch and/or the Refill Switch.
- Lower Level Switch serves as the process start indicator. Once the water level activates the switch, it turns on the controls for the steam valve and activates the fan if no other alarms are present.
- Fill Valve displays ON if the valve is energized or OFF if the valve is de-energized.
- Drain Valve displays ON if the valve is energized or OFF if the valve is de-energized.
- Tempering Valve, if applicable, will provide supply water to the draining water when activated in order to lower the hot water temperature being drained from the reservoir.

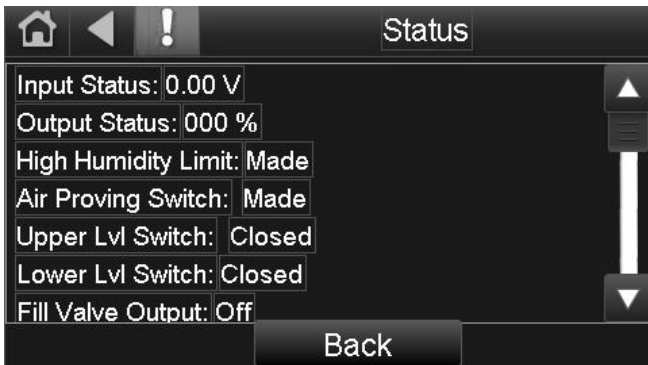

### Login Screen

The Login Screen, with the correct password, gives the end user direct access to the Parameter Screen and the Configuration Screen simultaneously. The password is factory set at 2222. If login is not accessed at this menu, the password will have to be entered separately for each screen.



### Configuration Screen

The Configuration Screen (password required) gives the end user access to adjust system parameters that are not typically necessary during normal operation. Below is an explanation of each configuration function.

- The Maximum Output percentage allows the end user to scale back the unit capacity to produce steam through the modulating steam valve.
- The Fill Duration Time is an end user adjustable fill

duration timer that can be used to control water usage. The time range is between 15 to 30 minutes. This is usually factory-adjusted to ensure water level reaches the high level float switch or the skimming level, depending on the water quality. Factory set is 22 minutes.

- The End of Season is an automatic draining process based on a predetermined time in hours if the system has not been called to produce humidity. The end user can change time intervals and draining time. The EOS drain interval can be a set time between 24 and 168 hours. This interval time is end user adjustable but factory set at 72 hours. The EOS drain can be set between 30 to 45 minutes and is factory set at 30 minutes.
- TRION recommends only using the Touchscreen configuration access for “calibrating touch panel” and “clean screen”. Clean screen gives the end user 60 seconds to wipe the screen down before returning. The “inactivity time-out” is the time delay before the present screen switches to the standby screen (minute increments).
- The Module Status menu contains read-only data of the system operation.
- The Module Setup is where the end user can change the time for a specific time zone and change the date. **TRION recommends not changing any other setting to prevent loss of system communication.**

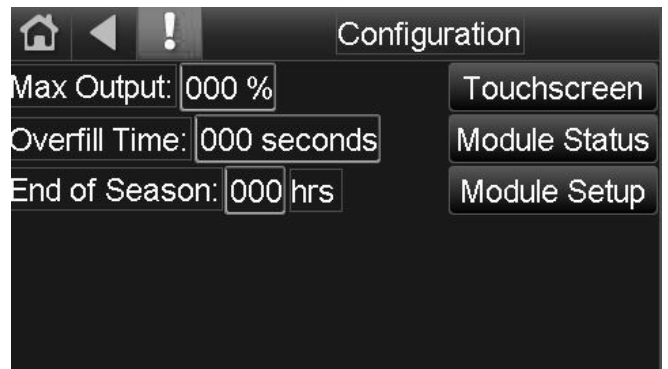

### Alarm Screen

The Alarm Screen is a hidden screen that only appears when an alarm is present. Each screen will show a grayed-out exclamation point that will turn red in the event of an alarm. Touching the red exclamation point will automatically take you to the active Alarm Screen. Once in the Alarm Screen, there will be a large gray arrow to the left of the red exclamation point. When selected, this screen will allow the end user to view active alarms.



The alarm must be reset in the program by turning the selector switch from the ON to the OFF position. Wait for the exclamation point to turn gray before turning the controller back on. This alarm clearing process may take 5-10 seconds to update. The alarm will reoccur if the fault has not been corrected.

To review previous time-stamped alarms, all active alarms must be manually cleared according to the instructions above. Once the alarms are cleared, touch the exclamation point to allow the controller to upload the alarm history. Once loaded, touch the tab that reads "Return-to-Normal". This will upload the alarm history to the screen in chronological order.

## X. STARTUP AND OPERATIONS

### Mounting

Check mounting to see that unit is level and securely supported before filling with water.

### Piping

Verify all piping connections have been completed as recommended and that steam and water pressures are available.

### Electrical

Verify that all wiring connections have been made in accordance with wiring diagram.

### Startup for Humidifier

1. Open shut-off valve on the water supply line.
2. Activate the power at the Controller. This will open the solenoid-operated water fill valve, filling the evaporating chamber.
3. The initial filling process is based on the time set in the configuration for the Fill Duration Time. Typically set by the manufacturer, this time is important in the refilling process because it ensures that the water level reaches the high level float or the skim process. **The initial fill has to close to High Limit Switch.**
4. When water level reaches the Low Limit Float Switch, it will open the proportional control steam valve and activate the fan if no alarms are present.
5. Check out function of field-installed airflow switch, high limit duct humidistat, and humidity controller to ensure that they are in control of the steam valve.

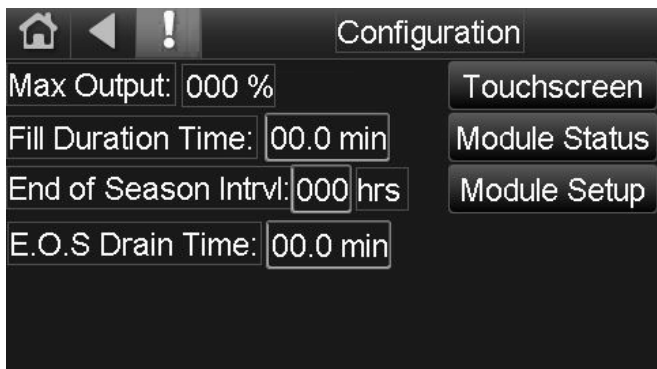

### Startup for Supply Steam

1. Turn all humidistats to the OFF position.
2. Open the supply steam valve and allow the supply condensate trap to warm up and drain away condensate from the supply piping.
3. Set desired relative humidity on the high limit humidistat. Recommended setting is 85%.
4. Increase the setpoint on the humidity controller to allow the steam valve to open and supply steam to the heating coil.
5. After the humidifier has run for a period of time, turn the control humidistat off so that the humidifier steam valve closes. Then close the supply steam valve to the humidifier.
6. Remove the strainer screen from the inlet strainer and clean. Check the steam traps to ensure they are also clean.
7. Test all humidistats and airflow switches to ensure they are operating properly.
8. Reset control device to the desired setpoint.

### Surface Skimmer (Skim timer required with raw water only)

Each time the evaporating chamber refills, the upper 1/4" of water is immediately drained off through the skimmer. The time of drain for the skimmer can be set for zero to five minutes. The skimming process removes the mineral residue that was formed during the previous evaporating cycle. This skimming process reduces the frequency of cleaning and allows the humidifier to operate at peak performance.

### Draining

This system provides automatic drain cycles. The drain solenoid valve can be cycled to open within a range of eight to 48 hours. The time interval of drain can be varied from five to 35 minutes.

### Drain Water Tempering

If drain tempering is required, it may be activated in the Parameters menu on the controller and will open a fresh water solenoid valve during draining operations, thus adding fresh water to the heated drain water.

## XI. RECOMMENDED MAINTENANCE

### Caution

Allow unit to cool before performing any maintenance. To accelerate the cooling process, manually drain the unit using the control interface. The tank will begin to drain. When the tank is drained, deactivate the manual drain mode and allow the unit to refill. Repeat this as required until the tank is cool enough to be touched safely.

Herrmidisteam is designed to deal with dissolved minerals in one of two ways, depending on the degree of hardness (up to 10 grains per gallon). The surface skimmer action plus periodic cleaning is usually adequate. For high mineral content water (above 10 grains per gallon), a periodic drain and flush along with periodic cleaning may be helpful. The frequency of cleaning will be dictated by water condition and evaporation load. Unit conversion: 1 grain CaCO<sub>3</sub> (calcium

carbonate)/gallon = 17.1 mg/L = 17.1 ppm, convert 10 grains/gallon = 171 mg/L = 171 ppm.

### Caution

WHEN PERFORMING MAINTENANCE ON THIS SYSTEM, ALWAYS TURN THE ELECTRIC POWER OFF AT THE CONTROL PANEL. CLOSE STEAM SUPPLY AND WATER MAKE-UP VALVES.

### Seasonal Maintenance

1. Cleaning the tank: remove loose scale in humidifier tank before the build-up reaches the underside of the heat exchanger(s).
2. Cleaning magnetic float: remove any scaling on the movable floats and the float rod using stainless steel wool. Ensure that the floats move freely.
3. Cleaning skimmer section: Clean any scaling inside the skimmer tray. Loosen deposits from the piping to the tray using a pipe brush or any long tool. Flush the piping to remove any remaining residue.
4. Inspect gaskets: for tears or improper seal. Replace as necessary.

### Out-of-Season Maintenance

After the humidification season, a complete inspection and cleaning of the heat exchanger(s), float system, skimmer, and

water chamber are recommended. After cleaning, the unit should remain empty until humidification is required.

### Adjusting the Surface Skimming

The skim time determines the quantity of water skimmed with each fill cycle. The skim time is adjustable as noted in the controller section of this manual.

### DI/RO Water Only

The humidifier should be inspected for leaks at least annually. All safety devices in the control cabinet should be cycled on and off to verify that they are functioning.

### Cleaning the DI Evaporating Chamber

As long as mineral-free water is used in the DI humidifier, no cleaning or flushing of the evaporating chamber should be necessary.

### Cleaning the Steam Distribution System

1. Strainers: Once per year, check the strainer for proper operation. Open a valve or plug on the exhaust port for self-cleaning.
2. Traps: Once per year, check for proper operation. All the working parts on the traps are accessible without removing the trap from the system piping. The F&T traps have a clean-out plug at the bottom of the trap body for easy flushing.

### Field Wiring Diagram

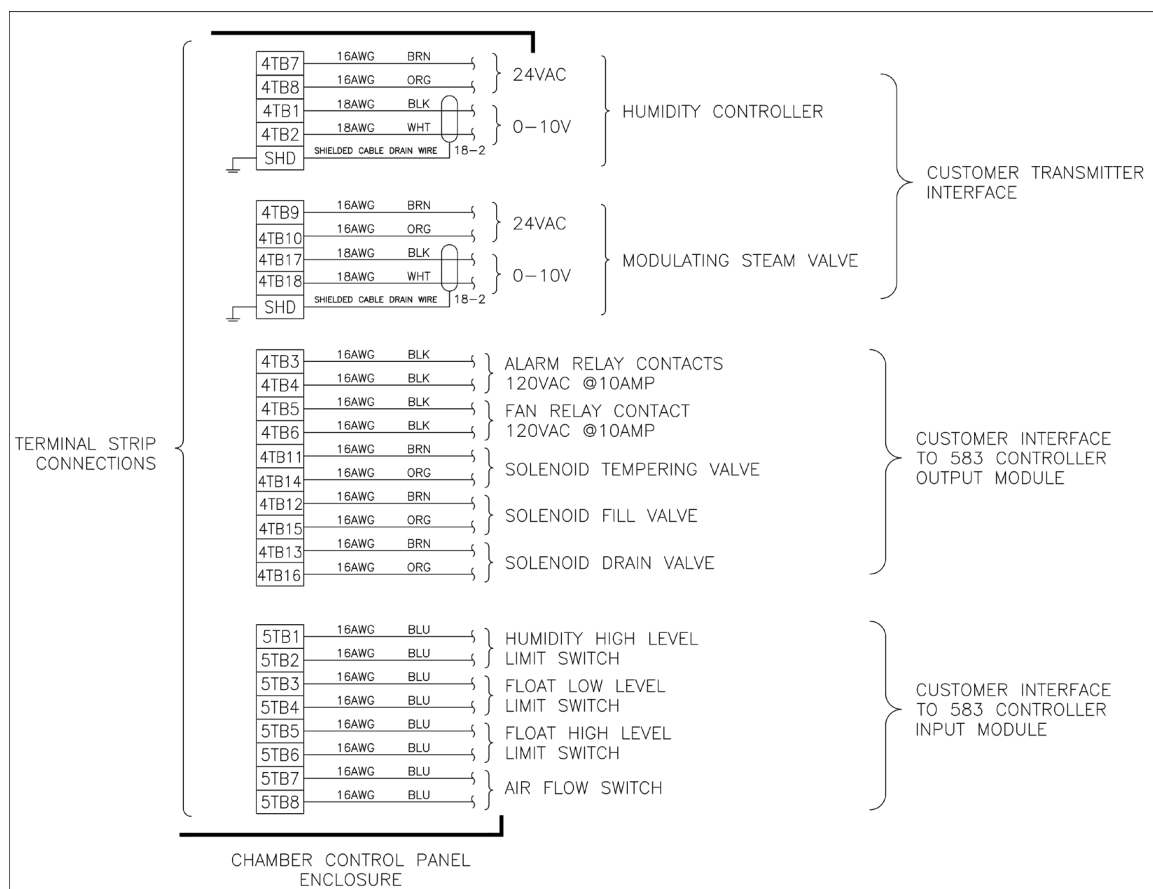

## XII. TROUBLESHOOTING

	Possible Cause	Recommended Action
Humidifier will not operate or heat up	No control transformer output. Humidistat is not calling.	Verify control voltage. Set humidistat to "call" and inspect for faulty humidistat.
	Safety controls open (high limits, air proving, etc.)	Check safety controls.
	Faulty control board	Verify control voltage and that float wires are correctly connected.
	Steam stop valve closed	Verify valve is opened.
	Steam trap plugged	Clean, service, or replace steam trap.
	Low or no steam output	Verify inlet steam is present.
	Steam strainer plugged	Clean, service, or replace strainer.
Humidifier will not fill	No water pressure	Verify manual water supply valve is open.
	Fault water fill valve	Verify action of fill solenoid valve and verify voltage is present at coil. Audible click should be heard as valve operates.
	Plugged water strainer	Open strainer.
	Plugged valve	Clean valve.
	Faulty control board	Verify control voltage.
Humidifier does not stop filing	Float malfunction	Clean, replace float.
	Drain valve is not fully closed.	Check valve for foreign matter.
	Fill valve is stuck open.	Check valve for foreign matter.
	Fill valve is installed backwards.	Check valve for flow direction.
Low steam output	Automatic drain valve not seating	Clean ball and seat of valve.
	Excessive skimming time	Reduce skimmer time.
	Fill valve is stuck open.	Check valve for foreign matter.
	Low supply steam pressure	Check steam supply pressure.
	Steam valve inoperable	Not fully opening
	Steam trap blocked	Not passing condensate
Makeup water valve short cycles	Scale-coated heat exchanger	Clean heat exchanger.
	Magnetic float incorrectly wired	Verify float wiring matches wiring diagram.
	Float is coated with scale.	Clean float.

## XIII. PARTS LIST

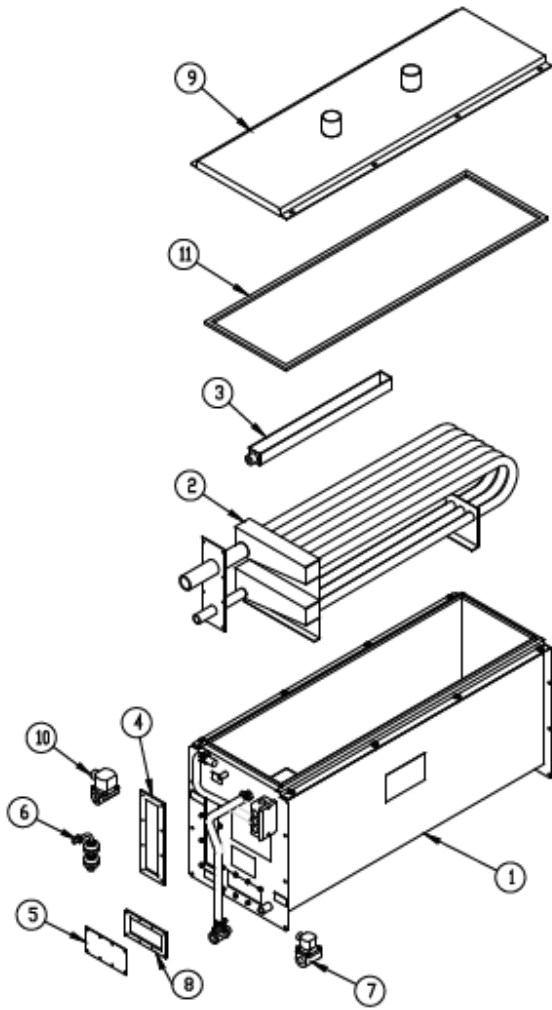

SS-200 Parts List		
No.	Description	
1	Tank assembly	Consult factory for pricing and availability
2	Heat exchanger	
3	Skimmer	
4	Gasket	
5	Access cover	
6	Float switch	
7	Solenoid valve, drain	
8	Gasket	
9	Cover	
10	Solenoid valve, fill	
11	Gasket	

## XIV. Options & Accessories

### Optional Drain Tempering Piping Schematic

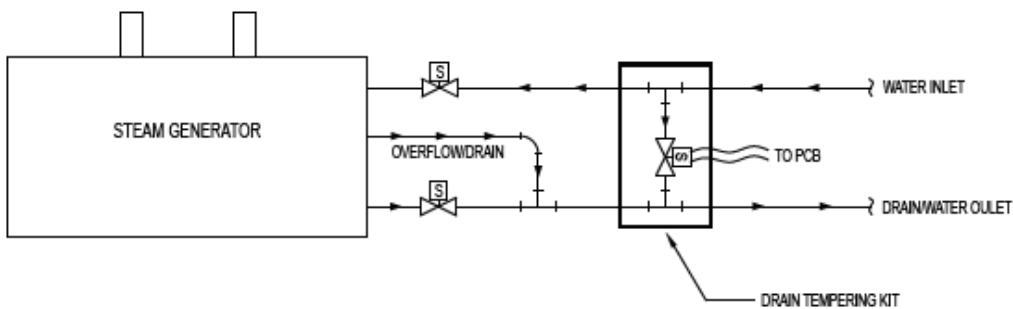

**NOTES:**  
 1. DIAGRAM ONLY SHOWS INSTALLATION LOCATION FOR DRAIN TEMPERING KIT.



---

TRION®

101 McNeill Rd. | Sanford, NC 27330

P: 800.884.0002 | F: 800.458.2379 | [www.trioniaq.com](http://www.trioniaq.com) | [customerservice@trioniaq.com](mailto:customerservice@trioniaq.com)

---