

This Owner's Manual is provided and hosted by [Appliance Factory Parts](#).



# TRION CFS22 Owner's Manual

[Shop genuine replacement parts for TRION CFS22](#)



[Find Your TRION Humidifier Parts - Select From 27 Models](#)

----- Manual continues below -----

# TRION®

Indoor Air Quality

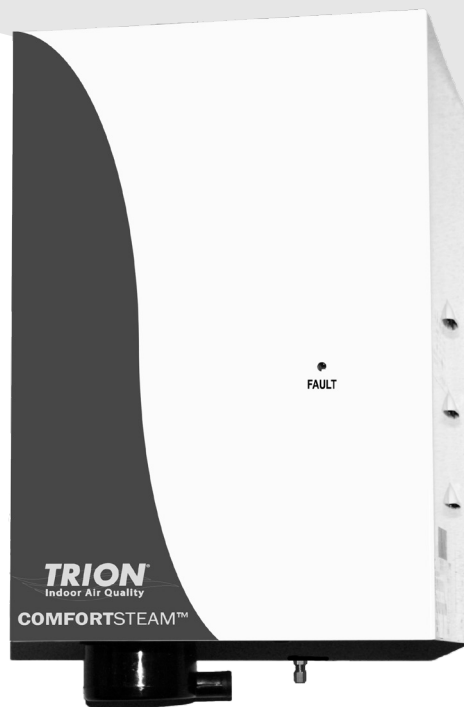

READ AND SAVE THESE INSTRUCTIONS

*UNITS NOT FOR COMMERCIAL USE*

**COMFORTSTEAM™**  
**CFS20 & CFS22**  
Humidification System Series

## TABLE OF CONTENTS

### SECTION I WARRANTY

Preface .....	3
---------------	---

### SECTION II UNIT OPERATION

Basic Operation Overview .....	4
What's in the Box .....	4
Key Features .....	5
Engineering & Application .....	6

### SECTION III INSTALLATION INSTRUCTIONS

Mounting .....	7
Plumbing .....	7
Steam Distribution .....	8
Wiring .....	9
Supply Power .....	9
Control Circuit Connections .....	9

### SECTION IV OPERATING INSTRUCTIONS

Installation Checklist .....	10
Start-up Instructions .....	11
Maintenance .....	12

### SECTION V TROUBLESHOOTING GUIDE

Board Test Points .....	13
Unit Detected Faults: (Red Service Light On) .....	14
Non-fault Activated Problems .....	15
Wiring Diagrams .....	17
Exploded View .....	18
Parts List .....	19

## SECTION I WARRANTY

### Warranty

1. TRION warrants to the buyer or any user during the duration of the Warranty that the humidifier described in this manual will be free from defects of material and workmanship for a period of 24 months from install or 30 months from shipment (excludes replaceable steam cylinder), whichever comes first.
2. For this Warranty to be effective, this humidifier must be installed, operated and maintained in accordance with the Installation Instructions, Operations and Maintenance Manual(s) supplied with the humidifier.
3. In the event of a defect or malfunction in this product during the Warranty Period, user may contact the Customer Service Department or their TRION Representative for a Customer Relations Management (CRM) number. Items tagged (on the outside of the box) with this number may be returned to TRION for replacement. Incidental expenses such as cost of transporting the humidifier to TRION or labor associated with removal/replacement of the parts shall be paid by the user. Upon completion of the reconditioning, the humidifier will be returned at no cost to the user. Items returned without a CRM number will not be accepted!
4. Every CFS20/22 series steam generating humidifier contains a plastic steam generating cylinder which is to be considered a routinely disposable part to be changed at regular maintenance intervals at the user's expense. This steam generating cylinder is not covered by this Warranty. If, after the installation of your CFS20/22 humidifier, you feel the steam generating cylinder is not operating normally, you should contact TRION with an explanation of the problem. However, in the continuing operation of the humidifier, replacements of this part are your responsibility as part of routine maintenance.
5. **This Warranty does not cover field labor for repairs to this humidifier or any special, indirect or consequential damages.** Some states do not allow the exclusion or limitation of incidental or consequential damages, so the above limitation may not apply to you.
6. If, after a reasonable number of attempts to do so, TRION is unable to remedy any defects or malfunctions in this humidifier, then the user may elect either a replacement of such product or part which may be defective without charge or a refund of the buyer's original purchase price.
7. This Warranty gives you specific legal rights, and you may also have other rights which vary from state to state.

**NOTE: Water quality plays a vital role in the performance and maintenance requirement of any humidifier. Adjustments to the circuit board may be necessary based on the incoming water quality. See pages 13-16.**

**Performance problems associated with water quality are not warranty issues!**

## SECTION II UNIT OPERATION

### Basic Operation Overview

Controlled humidification requires a very precise control system. The CFS20/22 utilizes a microprocessor based control system to monitor performance and maintain capacity. The humidifier evaluates the operation and alerts the operator to problem conditions and prevents undesirable operation.

1. On initial start-up or a call for humidity, the humidifier will attempt to fill to its full load amp rating. The unit will not necessarily have a full cylinder of water when capacity is reached. Water level depends on the conductivity of the water. The more conductive the water, the more current that can be passed through and will result in a lower water level during operation. If the water is not conductive enough to allow the unit to reach full load amps (full capacity) on the initial fill, the cylinder full module will stop the fill valve until the water conductivity increases. The unit will operate in this mode with repetitive fill and boil cycles until the unit has concentrated enough minerals in the water to reach the rated amp level. Once full load amp (FLA) has been reached, the fill valve will shut off. The unit will now compare the rate of change of amp draw to a time cycle.
2. Once the water in the cylinder is mineral laden and hence very conductive, a drain cycle will be initiated. Some or all of the water in the cylinder will be drained to flush away the minerals. After the drain cycle and/or the time cycle is completed, the unit will refill and start the process over. These cycles will repeat until:
  - The call for humidity is satisfied.
  - The cylinder is used up.
  - A fault condition occurs.
3. Over a very long term, as the electrodes in the cylinder are coated with minerals, the water level will slowly increase

to the cylinder full level. Concentration will no longer allow the unit to reach FLA. The unit will eventually display an "end of cylinder life" fault by blinking the LED on the front of the unit at 1/2 second intervals. Replacement of the cylinder is required at this point in order for the unit to continue operating at its rated capacity.

### What's in the Box?

#### Complete Humidification System

Part No.	Qty.	Description
267460-003	1	CFS20 Unit
267460-004		CFS22 Unit
AH-297	1	Air Proving Switch
267947-002	1	Parts Bag*

#### Unit Only

Part No.	Qty.	Description
267460-005	1	CFS20 Unit
267460-006		CFS22 Unit

#### Accessory Kit

Part No.	Qty.	Description
AH-297	1	Air Proving Switch
EST-596	1	Steam Hose, 1" ID
EST-1550	1	Duct Steam Pipe Assembly

\* Includes two lag screws (Part No. EST-1138), two 3/4" - 1 1/2" clamp hoses (Part No. EST 1563), one 12" clear PVC vinyl tubing with 1" OD (Part No. EST-206), and one stainless steel clamp hose (Part No. EST-207).

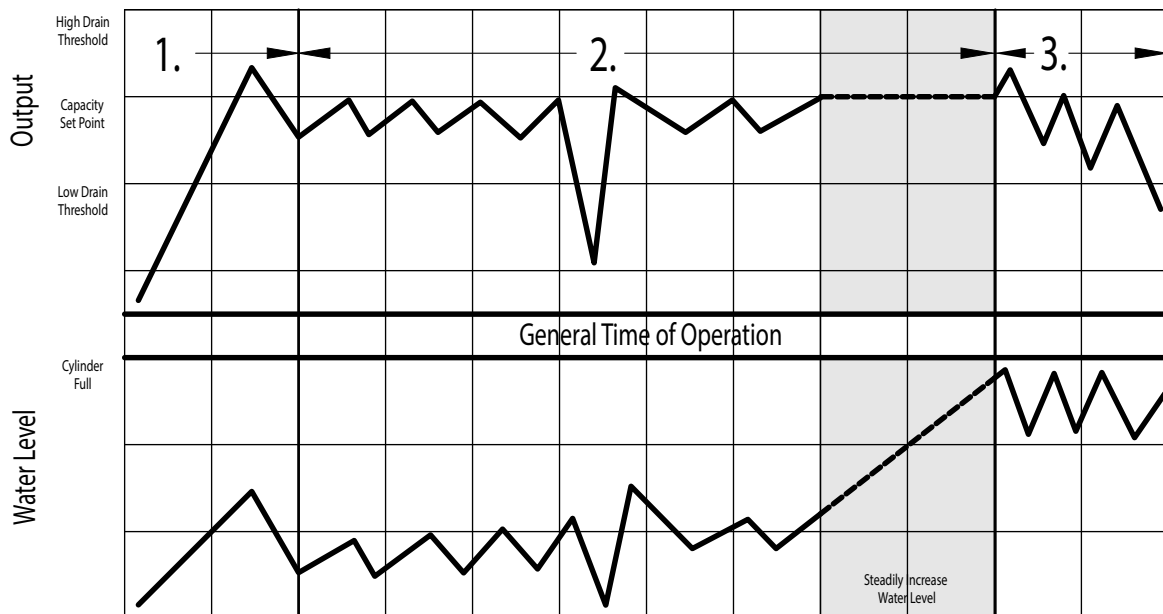

## Key Features

### Adjustable Setpoints (See Figure 13, Page 13)

**NOTE:** These setpoints should be adjusted by a qualified service person only.

#### Capacity

- Range = 50-100%
- Preset at 100%

#### Low Drain Threshold

- Range = 50-100%
- Preset at 80%

#### Cycle Time

- Range = 30-180 seconds
- Preset at 60 seconds

### Faults:

#### Overcurrent (Solid Light)

- 138% of Rated Current
- System Shutdown

#### Fill System (Slow Blink)

- Fill valve open for 24 minutes without achieving capacity setpoint or cylinder full
- System Shutdown

#### End of Cylinder Life (Fast Blink)

- 24 hours of operation while on cylinder full without achieving capacity setpoint.
- System Shutdown

- **Operation using water of less than 125 micro-Siemens is not recommended.**
- **Typically 500-2000 hours of cylinder operation can be obtained. Your actual cylinder life may be higher or lower depending on the exact composition of your water supply.**

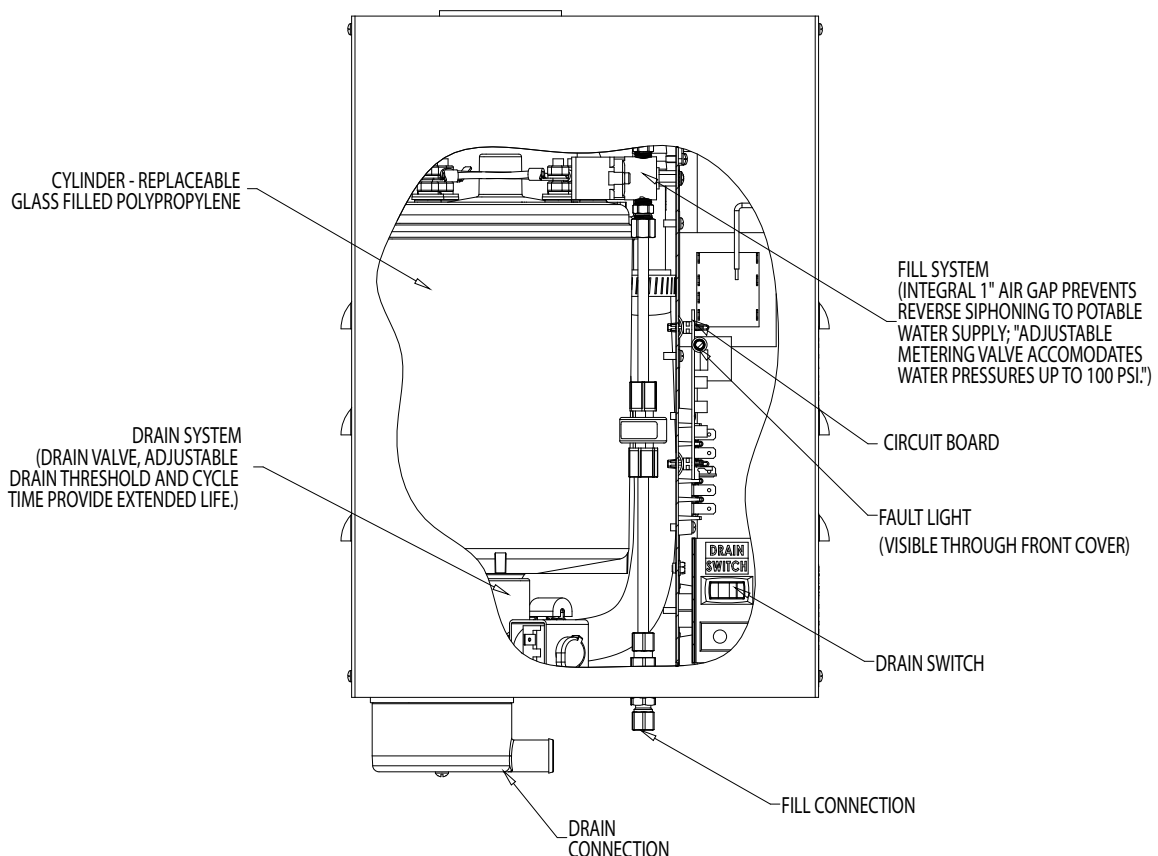

Figure 1

## Engineering and Application

The CFS20/22 series steam humidifiers can be applied in a variety of applications. The simplest application is to utilize the steam generated by the CFS unit to discharge it directly into the HVAC system ductwork. In this application, a steam pipe is preferably installed in the system ductwork at least 5 feet downstream of the supply air blower. There should be no obstructions within the first 5 feet downstream of the steam distributor as shown in Figure 2. A minimum duct temperature of 60° F is recommended. Different psychrometric conditions may require greater or lesser steam absorption distances. Temperatures below 60°F may cause condensation to form in the duct. External lined duct may be used if the thickness is 1" or less.

**NOTE: The steam distributor pipe is inherently sloped to return the condensate to the humidifier.**

An airflow proving switch is provided for a better system control. If the heating system operates for short periods at a time and the desired relative humidity level is not achieved, the humidifier can be wired to turn on the blower when there is a call for humidity. (See Figures 8-9, page 9.)

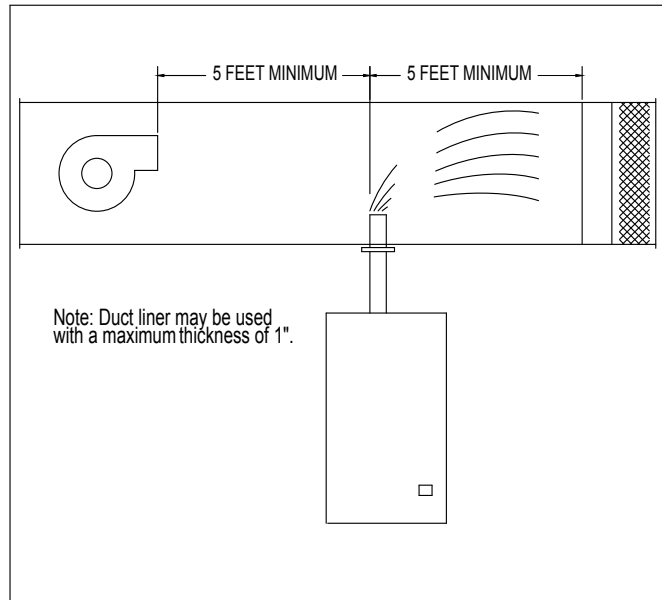

Figure 2

<b>Allowable Operating Conditions</b>	
Ambient Temperature	40°F (4°C) to 120°F (50°C)
Ambient Relative Humidity	0% to 90% (non-condensing)
Line Voltage	-15% to +10% of normal
Frequency	50/60 Hz
Water Supply Pressure	20psi - 100psi
Maximum Duct Static Pressure	1"

## SECTION III INSTALLATION INSTRUCTIONS

### Mounting

The cabinet is designed to safely contain the working components of the TRION CFS 20/22 series humidifier and dissipate heat to protect the electronics. Locate humidifier, steam pipe and accessories in a manner to allow routine inspection and any necessary maintenance. DO NOT install the unit above false ceilings or around valuable property, where a malfunction could cause damage. Correct positioning of the humidifier is important to allow for proper operation and easy maintenance. Minimum clearance around the cabinet should be maintained as follows:

Minimum Clearances Around Cabinet	
Left	6"
Right	12"
Top	6"
Bottom	12"

1. Remove cover by removing four side screws.
2. Remove foam packing from top of cylinder.
3. Two 5/16" lag bolts are supplied with the CFS20/22 unit. Install the lag bolts according to the dimensions in Figure 3.
4. Hang the unit on the wall and secure the bolts. Be sure the unit is level and mounted directly to the wall into wood studs at least 2" thick (or equivalent). Operating weight is 27 lbs.
5. Replace cover and four screws.

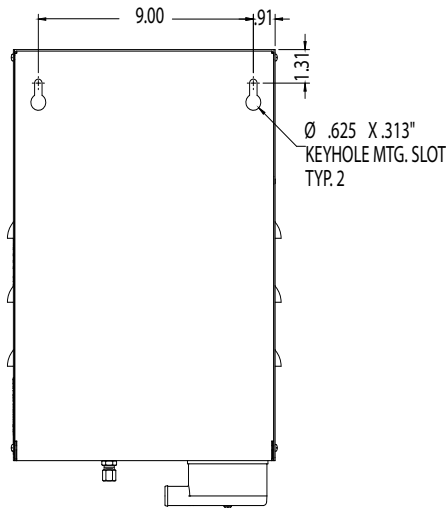

Figure 3 (Back View)

#### WARNING!

Do not mount any controls inside the unit or tap power from any location in the unit, except as stated in these instructions. Do not place objects near the cabinet. Do not attach to dry wall without studs. At least one of the 5/16" bolts must be located on a stud.

### Plumbing

To make the necessary connections for water fill and drain, the following steps are required. (Refer to Figure 4 for locations.)

1. Install external shutoff valve between the water supply and the humidifier for ease in servicing the unit.
  2. Connect water supply to the 1/4" compression fitting on the bottom of the cabinet.
- CAUTION!**

Do not use reverse osmosis or demineralized water treatment without first consulting the factory. This water may not be sufficiently conductive to allow proper operation. Consult factory if water is outside the range of allowable conductivities (125-1250 micro-Siemens). Do not use hot water.
3. Connect the 3/4" tube from the accessory pack to the drain reservoir. Cut the tube to the length necessary to reach the drain.
  4. Insert the other end of the tube into a minimum 6" vertical length of the 1-1/4" minimum I.D. drain line. The balance of the drain line should be 1" I.D. minimum with a minimum 1/8" per foot slope. (See Figure 4.)

#### WARNING!

If the drain line is exposed, it is recommended that it be insulated for safety. Do not use PVC drain line unless "Drain Tempering" is enabled.

**NOTE:** Inlet water pressure must be in the range of 20-100 psig. Consult the factory if you are outside this range. Softened water may be used but requires that the low drain threshold be adjusted.

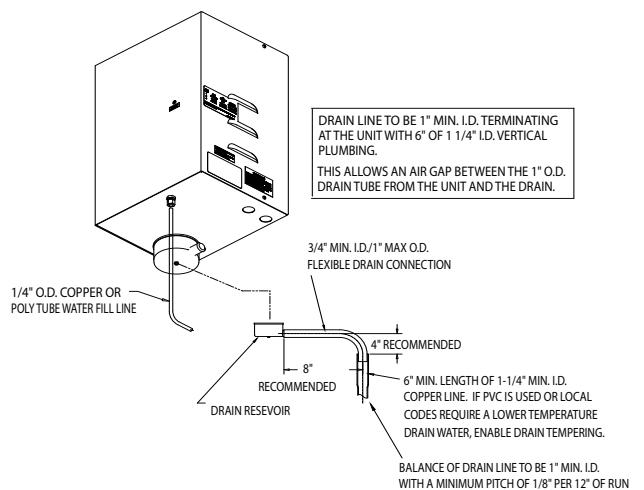

Figure 4

## Steam Distribution

TRION supplies a stainless steel duct distributor for injecting pure steam into the duct. This can be installed in the side (recommended) or the bottom (alternate) of the duct. (See Figure 5.) When installing in the side of the ductwork, make sure the unit is positioned to allow condensate to drain back down the steam hose to the steam generator. The duct distributor pipe has a built-in pitch to allow condensate to drain back into the hose. The hose must be installed with a minimum 8% (1" per foot) pitch back to the humidifier to allow condensate to drain back to the steam cylinder. (See Figure 5.) The steam hose may be used up to a maximum of 10 feet between the unit and the steam distributor. (Additional hose may be required.) There can not be sags in the steam hose, as this will create a trap and will produce back pressure in the steam cylinder and may blow condensate in the duct. (See Figure 6.)

## Distributor Mounting Instructions

### Sheetmetal Duct:

Make a 1-1/4" hole in the duct at desired location. Insert duct distributor and secure with self tapping sheetmetal screws (supplied by others).

### Fiberboard Duct:

Make a 1-1/4" hole in the duct at desired location. Insert duct distributor and mark the four holes on flange. Drill holes at marked locations. Fasten distributor with bolts (supplied by others).

**Note: Internally lined duct should be removed in the steam evaporation zone.**

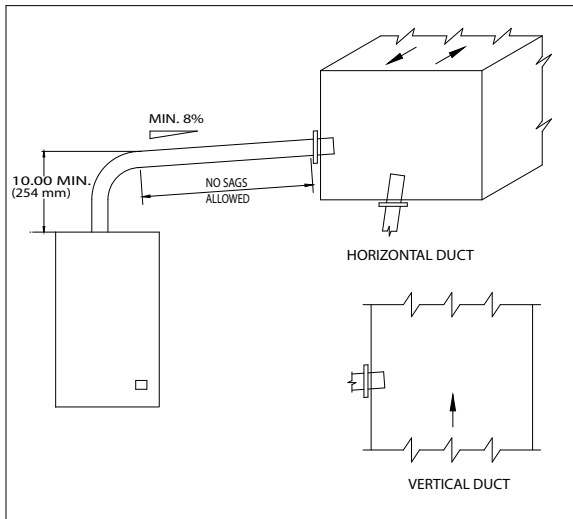

Figure 5

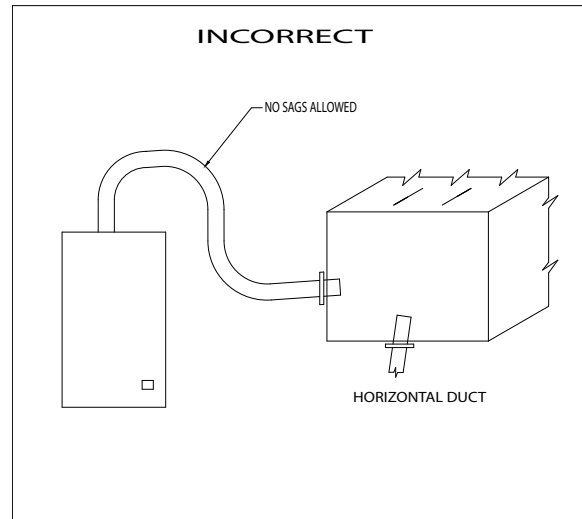

Figure 6

# Installation, Operation, & Maintenance Manual

## Wiring

All field wiring should be routed up through the holes in the bottom panel or in the back of the unit.

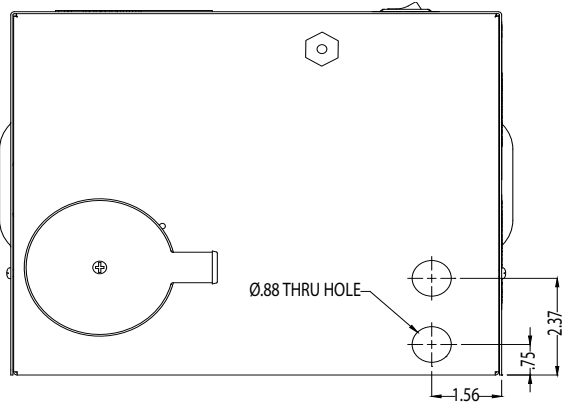

Figure 7 (Bottom View)

## Supply Power

1. Ensure that minimum circuit amperage capacity is 15 amps.
2. Terminals are provided in the electrical compartment for field connection of the main power supply legs (single phase) and a ground wire.
3. Install external overcurrent protection and provide wiring in accordance with the NEC, state and local codes.
4. Power supply must be "clean": free of spikes, surges and sags: -15% to +10% of nominal.

## Electrical Characteristics:

Model	CFS20	CFS22
lbs/hr	4	8
kg/hr	1.8	3.6
Voltage	115	230
Amps	11.5	11.5
kW	1.33	2.66

## Control Circuit Connections

### WARNING!

Do NOT install any controls inside the TRION CFS 20/22 cabinet. Installations of any extraneous devices inside the electrical compartment may cause erratic behavior of the circuitry and will VOID the warranty.

The humidifier is turned on by applying 24VAC across positions #3 and #4 of the terminal strip shown in Figure 8. The two most common ways to control the humidifier are to use a humidistat for automatic operations or to use just a basic switch to permanently turn on or turn off the unit.

### If using a humidistat for automatic control:

1. If the humidistat needs to be powered by 24VAC, then connect the humidistat power input to the humidistat 24VAC power output located on terminal strip position #1 (24VAC Hot) and position #2 (24VAC Common).
2. Connect the humidistat normally open contacts to the humidifier as follows. Connect one of the humidistat normally open contacts to the 24VAC Hot either from the humidistat power connection or from the humidifier terminal strip position #1. Connect the other humidistat normally open contact to position #3 of the humidifier terminal strip. Finally, connect the humidifier terminal strip position #2 to humidifier terminal strip position #4.

### If using just a basic switch for on/off control:

1. Connect the first side of the switch to humidifier terminal strip position #1.
2. Connect the other side of the switch to humidifier terminal strip position #3.
3. Finally, connect humidifier terminal strip position #2 to humidifier terminal strip position #4.

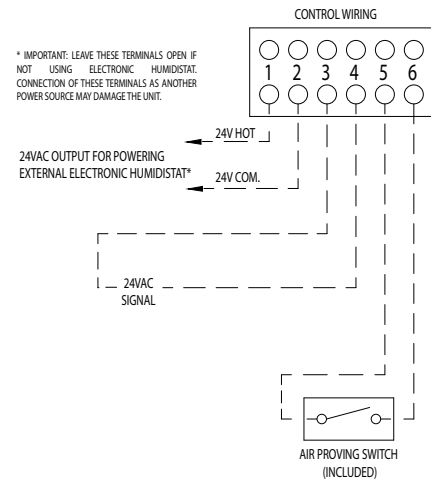

Figure 8

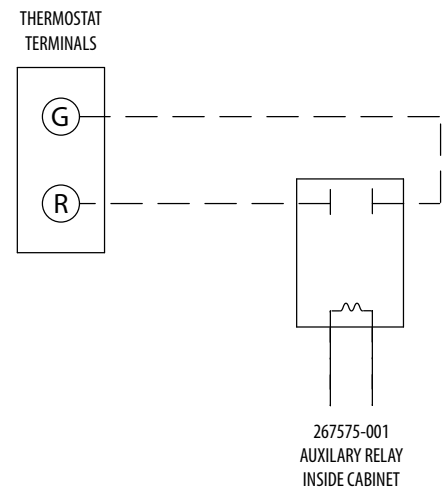

Figure 9

## Installation Checklist

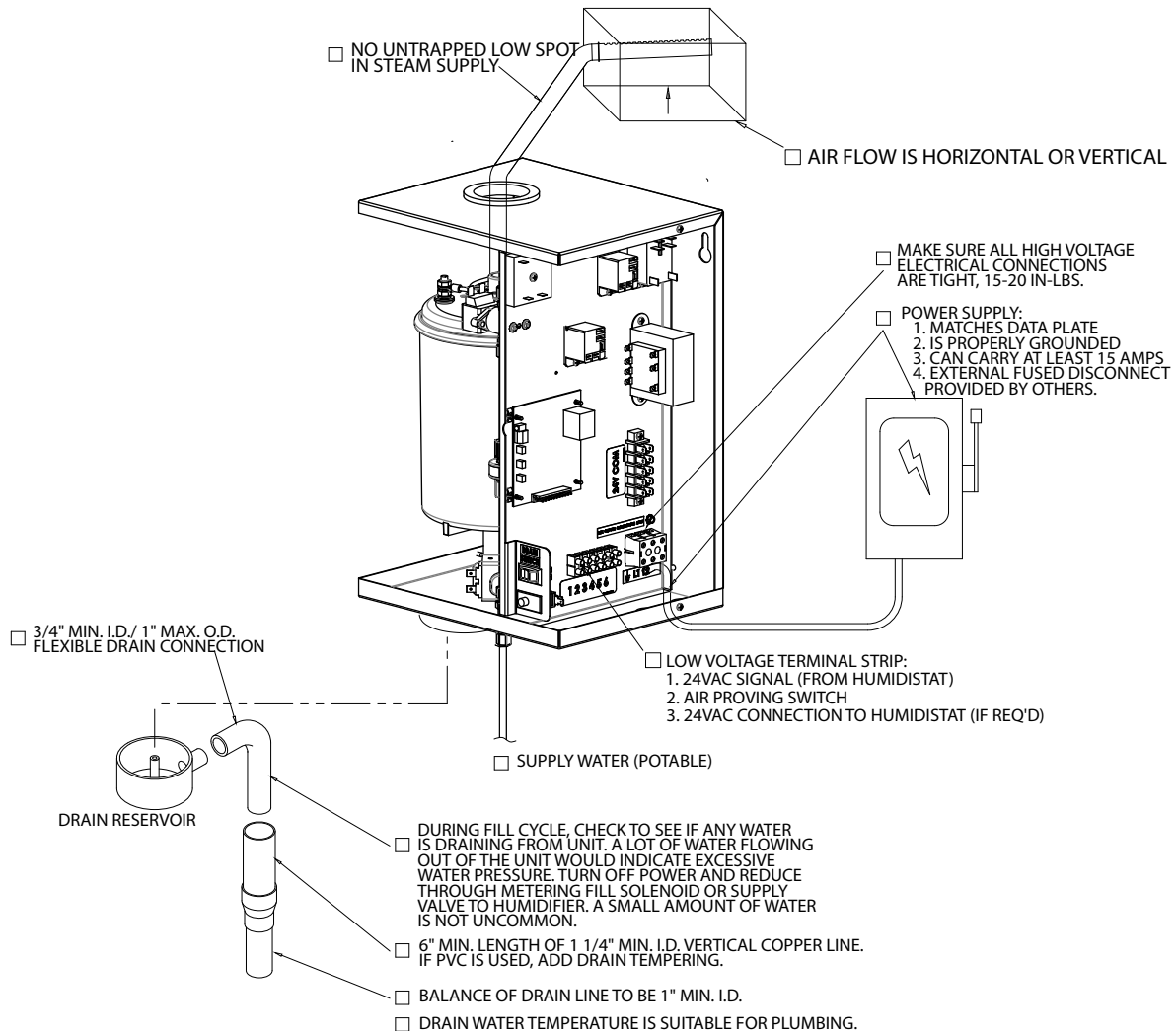

Figure 10

**NOTE:**

The TRION CFS20/22 Humidifier checklist is provided to help the installer ensure a successful installation. If further assistance is needed from the TRION representative or the factory, the checklist is expected to be completed. If a job site visit is required from the TRION representative or the factory, and the checklist has not been accurately completed, additional charges may be applied by the individual(s) representing TRION. If the visit uncovers a component malfunction, the parts will be replaced under warranty.

Project Name \_\_\_\_\_

Checklist completed by \_\_\_\_\_

Humidifier Installer (Company) \_\_\_\_\_

Checklist completion date \_\_\_\_\_

## SECTION IV OPERATING INSTRUCTIONS

Often in residential control environments and some other control system designs, the humidifier is controlled independently and may not be interlocked with the air blower control system. In these cases, the humidifier is equipped with an auxiliary relay (as shown in Figure 11). The auxiliary relay has one set of normally open contacts that can be used to control the air blower system. Those same normally open auxiliary relay contacts close when the humidifier is powered on and generating steam.

If required, the auxiliary relay's normally open contacts can be wired as needed to interlock the humidifier turn-on to the subsequently turn on the air blower system. See Figure 9 for a basic circuit diagram of the interlock connection of the auxiliary relay contacts to the red and green wires of a typical residential thermostat. Figure 9 is a very basic diagram and is for reference only. The auxiliary contact connection and control system interlock design should be designed and wired by a control engineer or by a licensed HVAC installer.

### Start-up Instructions

1. Check that the humidifier is properly mounted and level.
2. Check that the water fill and drain are properly connected.
3. Check that the correct voltage and amperage service are supplied.
4. Check that all controls are wired properly.
5. Check that the steam distributor is properly installed and that the steam hose has been properly routed without any kinks or flat spots.
6. With power OFF, double check all electrical connections and plumbing connections to ensure that they did not loosen during shipment.
7. With the control humidistat at the lowest setting, turn on the main disconnect. The contactor should remain deenergized.
8. Turn the control humidistat up to the highest setting. The relay should energize.
9. After approximately a five-second delay, the fill valve energizes and water begins to fill the cylinder to the preset amp level or cylinder full condition, depending on the incoming water supply. When starting up the unit, it is best to put an amp clamp on the power leg that passes through the toroid transformer. Ensure that the humidifier fills

**NOTE:** If upon initial start-up of this humidifier the cylinder is slow in heating and/or the service light continues to come on, drain the tank to 1/4 full. Turn off power at disconnect, obtain some Alka-Seltzer tablets and crumble 1/2 of one tablet (Alka-Seltzer) into the grey fill tee. Then turn the disconnect on and run the unit. If you have had to use this step on a 230V unit (CFS22), it is advisable that you order a 268613-001 replacement cylinder rather than the standard replacement cylinder in the future so this procedure will not need to be repeated.

to "cylinder full" (approximately 1.5" from the top of the cylinder), or that the amperage reaches the data label maximum and the fill valve de-energizes.

10. All units are equipped with a drain tempering feature which mixes cold fill water with the hot drain water to protect drain piping. **Unit is factory set with drain tempering inactive. To activate, move drain tempering jumper to ON position from circuit board.** (See Figure 13.) Depending on your fill water pressure, some adjustment of the fill metering valve may be necessary to ensure drain water of less than 140°F. (See Figure 11.)
11. Reset control humidistat to the desired setting. Refer to instructions supplied with humidistat.

**NOTE:** The capacity of the humidifier can be adjusted between 50% and 100% of the maximum level by adjusting the Capacity Adjustment Pot on the main circuit board.

### CAUTION!

Inadequate airflow may allow humidity to collect in areas causing condensation.

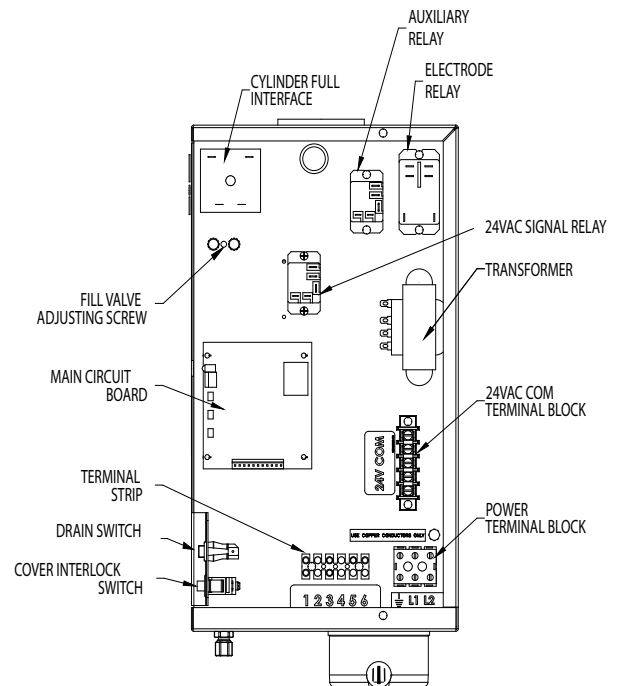

Figure 11 (View in from Right Side of Unit)

## Maintenance

To maintain output, the water level in the cylinder will slowly move upwards, exposing new electrode to the water as the electrodes become coated with minerals. Eventually, all of the usable electrode surfaces will be coated and the cylinder will be full of water. At this point, the output capacity will begin to drop and the red "fault" light will come on (fast blink). The unit will shut down. This indicates the need to change the cylinder, typically after 500-2000 hours of operation, depending on the quality of the fill water supply.

### To Replace the Cylinder

1. Remove cover and four screws while being careful of wiring. Drain cylinder completely using the drain switch.
2. Turn off power to the unit at the external disconnect. Disconnect electrode power wires (#32 & #33) and cylinder full electrode wire (#26) from the cylinder. These connections are 1/4" quick connects. (See Figures 12B, 12C, and 12D.)
3. Disconnect 1" hose at top of cylinder.
4. Remove cylinder, clean out the drain cup and insert the new

5. cylinder. Be sure that the o-ring is in place on the cylinder fill/drain port prior to installation. (See Figure 12A.) New o-ring is included with each replacement cylinder.
5. Clean and check both the fill and drain valves while servicing the unit.
6. Install cylinder in unit by pushing downward with a slight twisting motion, while ensuring proper orientation of cylinder within cabinet.
7. Reconnect electrode power wires (#32 & #33) and cylinder full electrode wire (#26). Make sure that all electrical connections are securely tightened. (See Figures 12B, 12C, and 12D.) Replace cover and four screws.
8. Follow cold start-up instructions on page 11. Monitor amp draw for several cycles.

### Extended Shutdown

Always drain cylinder completely if unit will be off for an extended period of time. This will preserve the life of the cylinder.

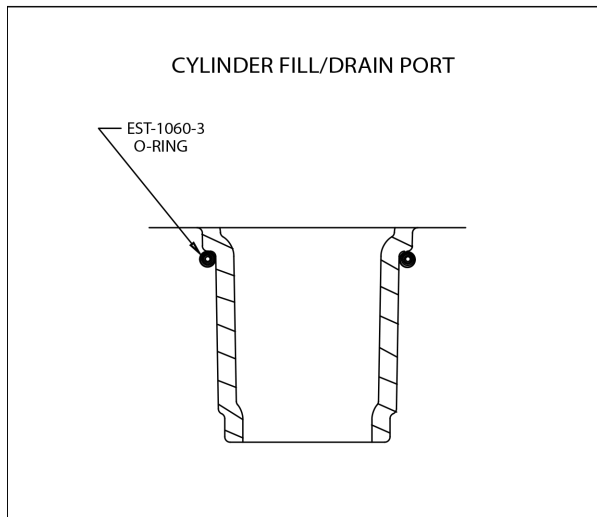

Figure 12A

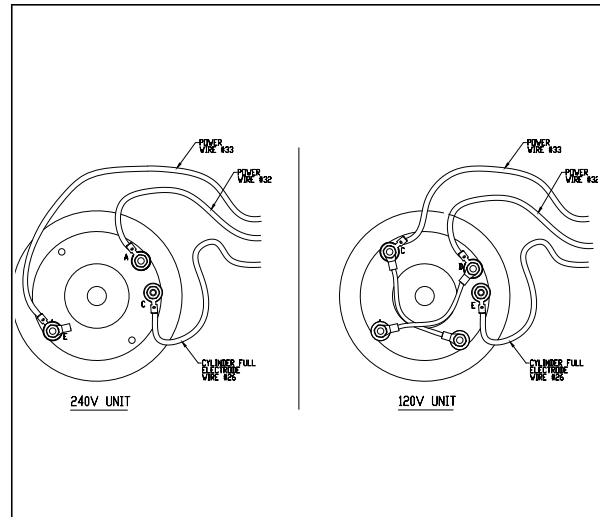

Figure 12B

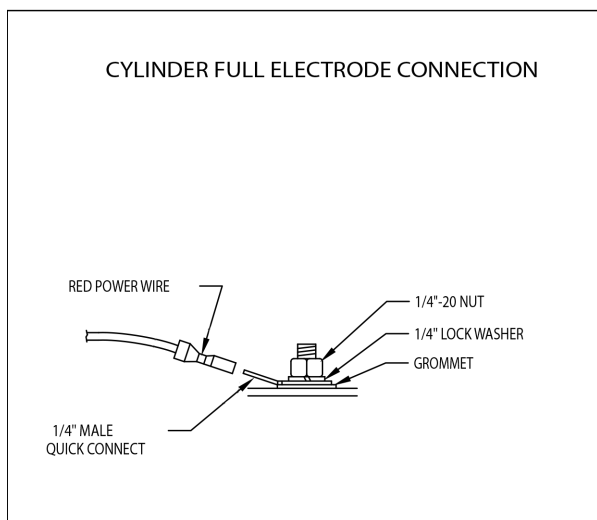

Figure 12C

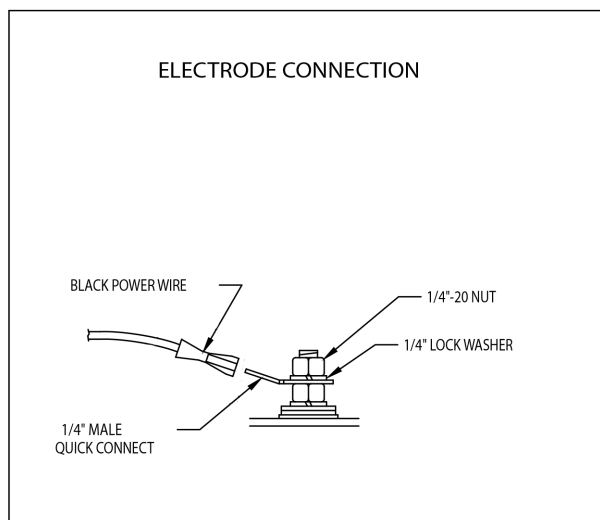

Figure 12D

## SECTION V TROUBLESHOOTING GUIDE

All TRION CFS 20/22 series humidifiers are manufactured under strict quality control and are subjected to a complete operational test prior to shipment. All circuit board adjustments are made at the factory and should not be adjusted beyond the guidelines set in this troubleshooting guide without first consulting a factory representative. The following information is for your help and reference. If you still experience difficulty after trying these remedies, contact your TRION representative.

### WARNING!

The TRION CFS20/22 series electronic steam humidifier cabinet was designed to house and shield the components from outside interference. Absolutely NO other components may be mounted inside or be electrically tapped into the humidifier without TRION's express written permission. Failure to heed this warning will void your warranty.

## Test Points

Each circuit board (see Figure 13) features three test points to aid in the troubleshooting process. Each of these test points works on a 0-5 VDC scale. "0 VDC" = 0%. "5 VDC" = 100%. All readings are between the test point and ground.

### Test Point #1:

Provides exact reading of Time Cycle setting.  
30-180% = 0-5 VDC (Factory set: 1 volt)

### Test Point #2:

Provides exact reading of Low Drain threshold.  
50-100% = 0-5 VDC (Factory set: 3 volts)

### Test Point #3:

Provides maximum percentage of output.  
50-100% = 0-5 VDC (Factory set: 5 volts)

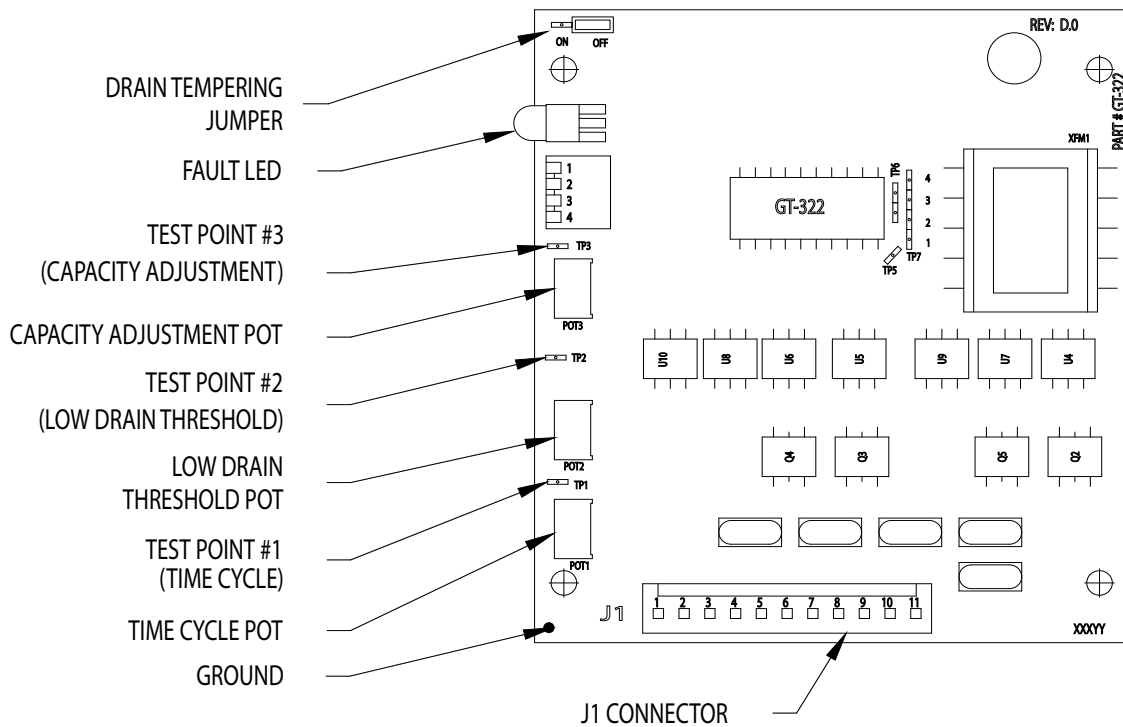

Figure 13

## Unit Detected Faults (Red Service Light is ON)

Problem / Symptom	Probable Cause	Reason - Correction
<b>Overcurrent (Solid Light)</b> The alarm condition occurs when an overcurrent situation (>138% of rated current) has occurred and the humidifier has shut down to prevent any damage. This alarm indicates that there has been a significant reduction in resistance between the main legs of the supply power and the humidifier has been shut down to prevent damage and should be serviced before it is restarted. Fault LED R33 will be illuminated (solid - no flash).	Dead short between electrodes.	Replace the steam cylinder. Check resistance between electrodes with power OFF.
	Restricted or blocked drain.	Clean and inspect drain system.
	Restricted fill system.	Clean and inspect the fill system. Check for restriction or loss of supply pressure.
	Incoming water conductivity is outside the range of normal circuit board settings.	Consult the factory for options.
	Check amp draw to unit during start-up. If amp draw greatly exceeds rated amp draw, the drain threshold pot, labeled "Low Drain Threshold Pot", must be increased 2% to increase the frequency and duration of drains to reduce the conductivity inside the cylinder.	Manually drain the unit and restart.
<b>End of Cylinder (Fast Blink)</b> This alarm condition occurs if the humidifier is unable to reach full output over a 24 hour timeframe. It is constantly switching between "fill" and "cylinder full" modes. This alarm indicates a need to change the cylinder, that the water supply is low in conductivity, or that a foaming condition exists.	End of cylinder life – Cylinder life is typically between 500 and 2000 hours, depending on incoming water supply.	For emergency use, you may restart the humidifier with the Capacity Adjustment Pot at a lower level to allow operation until a replacement steam cylinder can be obtained. To clear the fault, turn the main disconnect to the unit "off" and then back ON.
	If incoming water supply is less than 125 micromho, the unit may not be able to pass the rated current through the water.	See NON-FAULT ACTIVATED PROBLEMS GUIDE – "Unit fills to the cylinder full condition and remains cold."
	Foaming condition exists.	Flush and fill the steam cylinder several times and restart. If it persists, you must filter or treat the water to remove the foaming agent. See circuit board settings on previous page if supply water is softened. See NON-FAULT ACTIVATED PROBLEMS GUIDE – "Water foaming inside the cylinder."
<b>Fill System Fault (Slow Blink)</b> This alarm condition occurs when the fill valve has been energized for a 24 minute timeframe. The humidifier has been shut down to prevent any damage.	Loss of or restricted water supply.	Check fill system.
	Leaking drain system.	Check drain system.
	Defective drain valve.	Repair and replace as required.
	Defective fill valve.	Repair and replace as required.

**NOTE: The three fault conditions outlined above will cause the humidifier to shut down and the fault light on the front of the unit to illuminate. To clear these faults, the main power must be turned OFF and back ON again.**

## Non-Fault Activated Problems

Humidifier turned ON but will not operate	Check power supply.
	Check circuit breaker.
	Check connector J1 on the circuit board and ensure that it is plugged into the circuit board properly and that no wires are loose.
	Ensure that there is 24 VAC between pole #9 and #11 connector J1. If not, check wiring.
	Place jumper between controls wiring terminal strip #3 and #4. If unit operates, check controls settings and wiring (control, humidistat.)
Check door interlock.	
Unit turned ON. Contactor pulled in, but no water is entering the cylinder.	Check external shutoff valves and open if closed.
	Check strainer and fill valve for clogs. Turn adjusting screw.
	Check fill valve coil to determine if it is receiving 24 VAC. If so, replace the valve.
	Check for break in wiring.
Excessive arcing in cylinder	Check drain valve and ensure that when it activates it drains freely. Clean if necessary. Replace valve if defective.
	Check water supply. If it is softened, increase the Low Drain Threshold Pot (POT 2) up to XX%. (See Figure 13.)
	Use high conductivity settings if water supply is very hard, >750 micromho.
	Unit filling slower or at the same rate as the water is boiling, causing over concentration and foaming. Check restriction in fill line. Adjust the metering fill valve to allow greater flow of water. (See Figure 11.)
	Have water analyzed. If iron content is greater than .1 mg/liter, a filter will have to be used.
	Consult factory with water analysis.
Unit fills to the cylinder full condition and remains cold	Check between Test Point #3 and ground with a multimeter set on VDC scale. Confirm the circuit board is seeing low current flow (<3.5 VDC). Proceed to next step.
	If on initial fill, unit reaches less than 70% of rated capacity (3.5 VDC on Test Point #3), adjust the drain threshold pot, POT 2, down 2-3%. Manually drain the unit down completely and add ½ Alka Seltzer tablet via the fill tee (GT-120). Restart the unit while monitoring the amp draw. Fill unit ¼ full and turn “off” for several minutes to allow tablets to dissolve. Restart unit. If amperage rises rapidly, it may be necessary to dilute the water. If amperage rises slowly, add another Alka-Seltzer tablet.
	Check that drain valve is sealing properly.
	Check the water conductivity and consult the factory.
Unit turned ON and cycles for a short period of time. Then it stops in the middle of a fill cycle and will not reset until boiling stops.	Check cylinder fill interface connections.
	Check cylinder connections. (See Figure 12B.)
	Check items in next troubleshooting tip concerning foaming.
	Check amperage between cylinder full electrode and cylinder full interface terminal #1. If it is greater than 7.0 mA AC, take a fill water sample and consult the factory.

# Installation, Operation, & Maintenance Manual

Problem/Symptom	Reason - Correction
Water "foaming" inside the cylinder	Check drain valve and ensure that water drains freely. If necessary, clean or replace valve if defective.
	Check water supply. If it is commercially softened, either increase the drain threshold (Test Point #2) to 85% or reconnect the unit to raw water. Drain and restart the unit. If the unit is connected to a hot water line, reconnect to the cold water line.
	If steam line is hard copper, drain cylinder and test unit operation disconnected from steam line to ensure flux from solder joints is not causing foaming.
	Observe the fill tee (GT-120). If water is going down the overflow and the water level is low: <ul style="list-style-type: none"> <li>• Check to ensure that static pressure in the duct is not forcing water down the overflow instead of allowing water to enter the cylinder.</li> <li>• Adjust the fill metering valve to regulate the water flow to the cylinder. (See Figure 11.)</li> <li>• Unit filling slower or at the same rate as it is boiling off, causing over concentration and foaming. Fill rate must be increased. Open metering valve.</li> <li>• If the fill valve is already fully open, get a water analysis and consult the factory.</li> </ul>
Cylinder fills and overflows	Check cylinder wiring (See Figure 12.)
	Check wiring of cylinder full interface.
	Replace the circuit board.
	Consult the factory after obtaining a water analysis.
Unit cycle ON and OFF rapidly	Check location and setting of humidistat.
Cabinet leaks	Check for loose connections.
	Fill tube out of fill tee.
	Steam cylinder out of drain cup.
	Cabinet drain backing up, kink in drain line.

## CFS20 Wiring Diagram

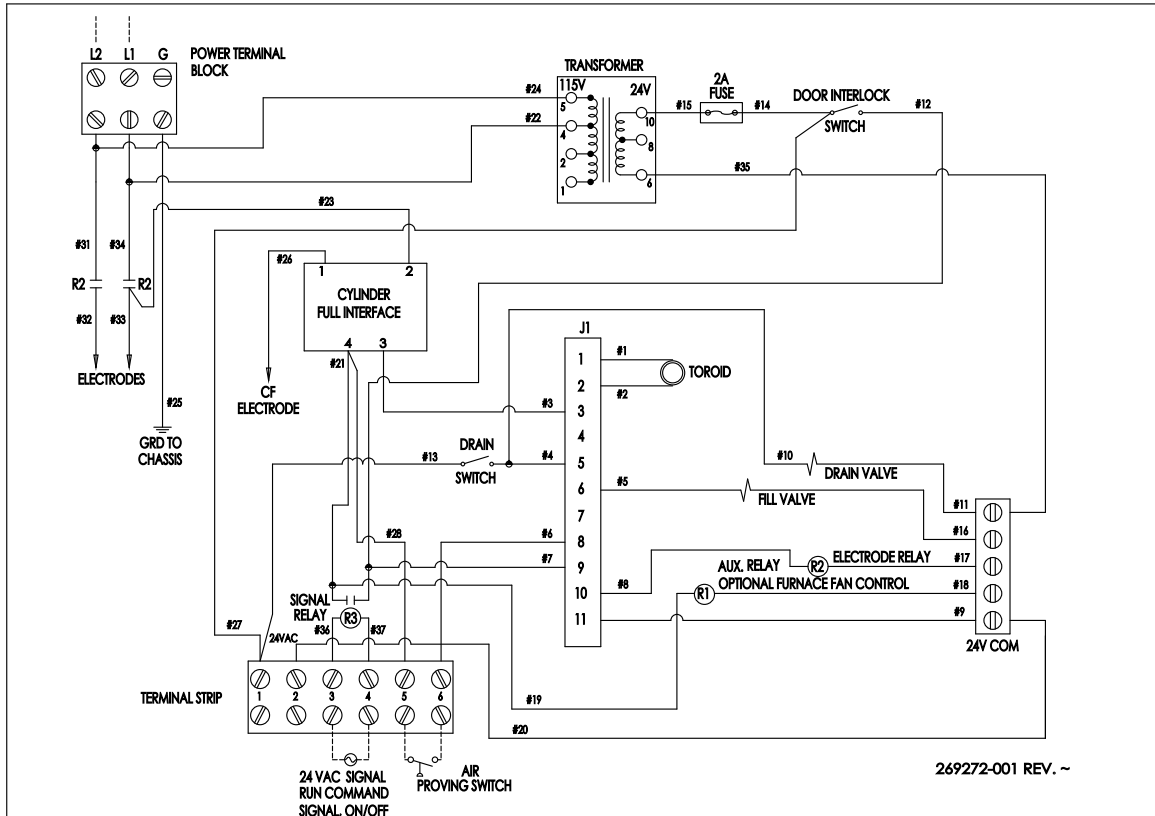

## CFS22 Wiring Diagram

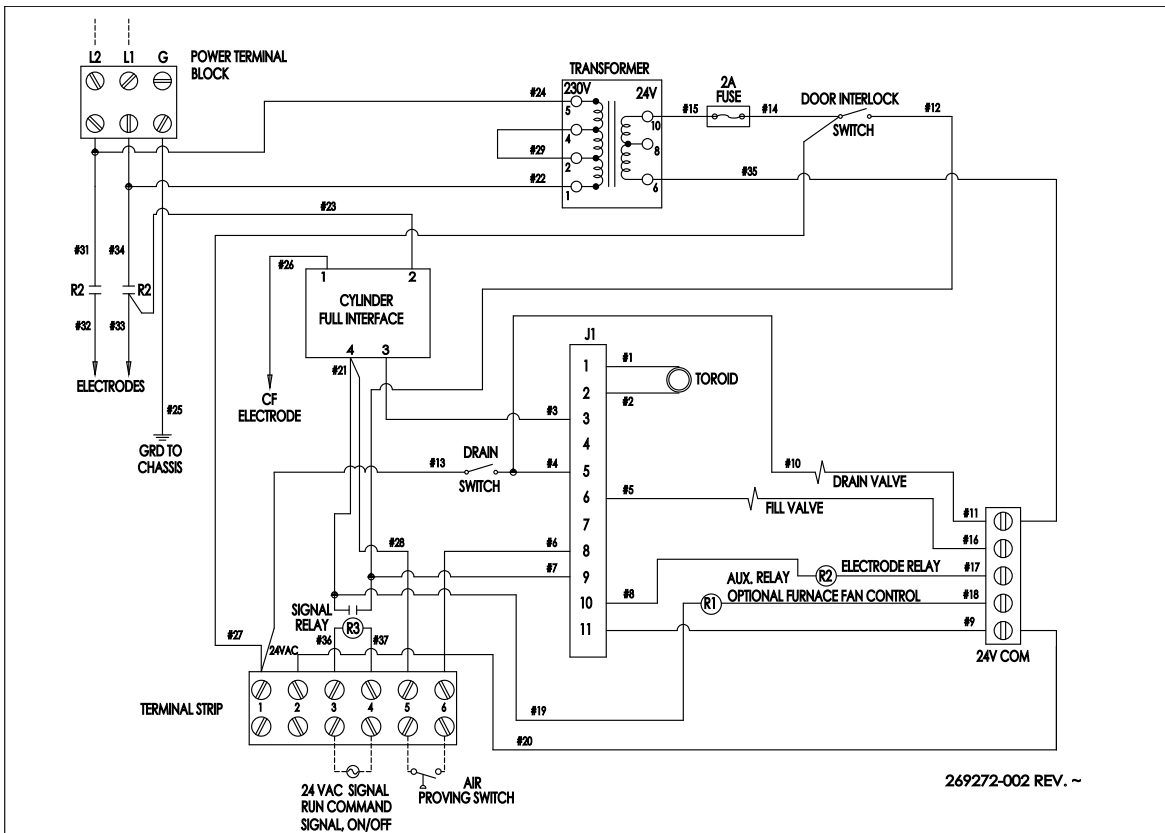

# Installation, Operation, & Maintenance Manual

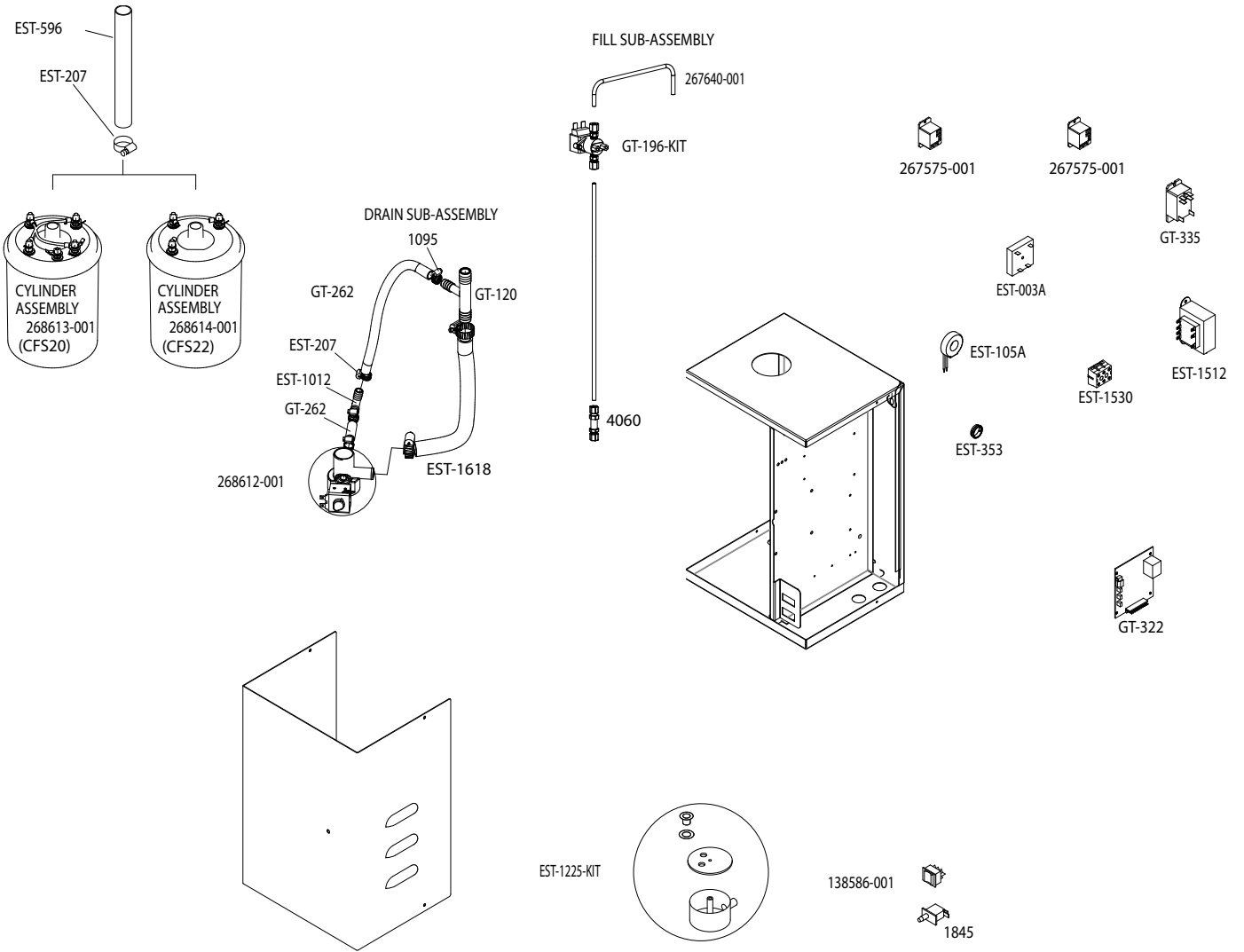

## Parts List

1095	Hose clamp SS
1845	Door interlock
4060	Fitting, 1/4" bulkhead
138586-001	Drain switch
267575-001	24VAC signal relay or auxiliary relay
267640-001	Fill loop
268390-001	Power wire assembly replacement (not shown)
268612-001	Drain valve kit
268613-001	Steam cylinder assembly (115V units)
268614-001	Steam cylinder assembly (230V units)
EST-003A	Cylinder full interface
EST-105A	Toroid transformer
EST-207	Hose clamp SS
EST-353	Bushing, short 3/4" I.D.
EST-596	Steam hose
EST-1225-KIT	Drain reservoir kit
EST-1512	Transformer, 115/230V to 24VAC
EST-1530	Terminal block
EST-1618	Tubing, 1" O.D. silicone
GT-120	Fill tee
GT-195-KIT	Fill valve replacement kit
GT-262	Hose, 1/2" I.D. overflow
GT-322	Main circuit board
GT-335	Electrode relay, 2 pole, 20A



---

TRION®

101 McNeill Rd. | Sanford, NC 27330

P: 800.884.0002 | F: 800.458.2379 | [www.trioniaq.com](http://www.trioniaq.com) | [customerservice@trioniaq.com](mailto:customerservice@trioniaq.com)

---