



READ AND SAVE THESE INSTRUCTIONS

Herrtronic® 6000 Series

Electrode Steam Humidifiers

TABLE OF CONTENTS

SECTION I WARRANTY

Preface	3
---------------	---

SECTION II UNIT OPERATION

Basic Operation	4
Key Features	5
Engineering & Application	6

SECTION III INSTALLATION INSTRUCTIONS

Mounting	6
Plumbing	7
Steam Distribution	7
Wiring	7
Supply Power	7
Control Circuit Connections	8

SECTION IV OPERATING INSTRUCTIONS

Start-up Instructions	8
Checklist	9
Maintenance	10

SECTION V TROUBLESHOOTING GUIDE

Board Test Points	11
Unit Detected Faults: (Red Service Light On)	12
Non-fault Activated Problems	13
Wiring Diagram	15
Exploded View	16
Parts List	17

SECTION I WARRANTY

Warranty

1. TRION/HERRMIDIFIER warrants to the buyer or any user during the duration of the Warranty that the humidifier described in this manual will be free from defects of material and workmanship for a period of two (2) years from the date of shipment.
2. For this Warranty to be effective, this humidifier must be installed, operated and maintained in accordance with the Installation Instructions, Operations and Maintenance Manual(s) supplied with the humidifier.
3. In the event of a defect or malfunction in this product during the Warranty Period, user may contact the Customer Service Department or their TRION/HERRMIDIFIER Representative for a Customer Relations Management (CRM) number. Items tagged (on the outside of the box) with this number may be returned to TRION/HERRMIDIFIER for replacement. Incidental expenses such as cost of transporting the humidifier to TRION/HERRMIDIFIER or labor associated with removal/replacement of the parts shall be paid by the user. Upon completion of the reconditioning, the humidifier will be returned at no cost to the user. Items returned without a CRM number will not be accepted!
4. Every 6000 series steam generating humidifier contains a plastic steam generating cylinder which is to be considered a routinely disposable part to be changed at regular maintenance intervals at the user's expense. This steam generating cylinder is not covered by this Warranty. If, after the installation of your 6000 humidifier, you feel the steam generating cylinder is not operating normally, you should contact TRION/HERRMIDIFIER with an explanation of the problem. However, in the continuing operation of the humidifier, replacements of this part are your responsibility as part of routine maintenance.
5. **This Warranty does not cover field labor for repairs to this humidifier or any special, indirect or consequential damages.** Some states do not allow the exclusion or limitation of incidental or consequential damages, so the above limitation may not apply to you.
6. If, after a reasonable number of attempts to do so, TRION/HERRMIDIFIER is unable to remedy any defects or malfunctions in this humidifier, then the user may elect either a replacement of such product or part which may be defective without charge or a refund of the buyer's original purchase price.
7. This Warranty gives you specific legal rights, and you may also have other rights which vary from state to state.

NOTE

Water quality plays a vital role in the performance and maintenance requirement of any humidifier. Adjustments to the circuit board may be necessary based on the incoming water quality. See pages: 11-14.

Performance problems associated with water quality are not warranty issues!

SECTION II UNIT OPERATION

Basic Operation

Controlled humidification requires a very precise control system. The 6000 utilizes a solid state control to monitor performance and maintain humidity. The humidifier evaluates the operation and alerts the operator to problem conditions and prevents undesirable operation.

On initial start-up or a call for humidity, the humidifier will attempt to fill to its full load amp rating. The unit will not necessarily have a full cylinder of water. Water level depends on the conductivity of the water. The more conductive the water, the more current that can be passed through the same volume of water.

If the water is not conductive enough to allow the unit to reach full load amps (full capacity) on the initial fill, the cylinder full light will indicate a full cylinder condition. The unit will operate in this mode with repetitive fill and boil cycles until the unit has concentrated enough minerals in the water to reach the rated amp level.

Once full load amp (FLA) has been reached, the fill valve will shut off. The unit will now compare the rate of change of amp draw to a time cycle.

If the water in the cylinder is mineral laden and hence very conductive, a drain cycle will be initiated.

After the drain cycle and/or the time cycle is completed, the unit will refill and start the process over.

These cycles will repeat until:

- The call for humidity is satisfied.
- The cylinder is used up.
- A fault condition occurs.

On initial start-up, if the water is not conductive enough for the unit to reach FLA, the water will stop filling when the water reaches the cylinder full electrode. Once the unit has entered a cylinder full condition it will operate with fill and boil cycles only. By eliminating the drain cycle, the water conductivity will be increased by producing pure steam and leaving the minerals behind. The increased mineral levels will raise the conductivity allowing the humidifier to draw sufficient amperage to achieve FLA. Normal operation will then commence.

As the electrodes in the cylinder are coated with minerals, the water level will slowly increase to the cylinder full level. Concentration of coating on electrodes will no longer allow the unit to reach FLA. After a period of time, the unit will display the red "Service" light indicating the need to change the cylinder.

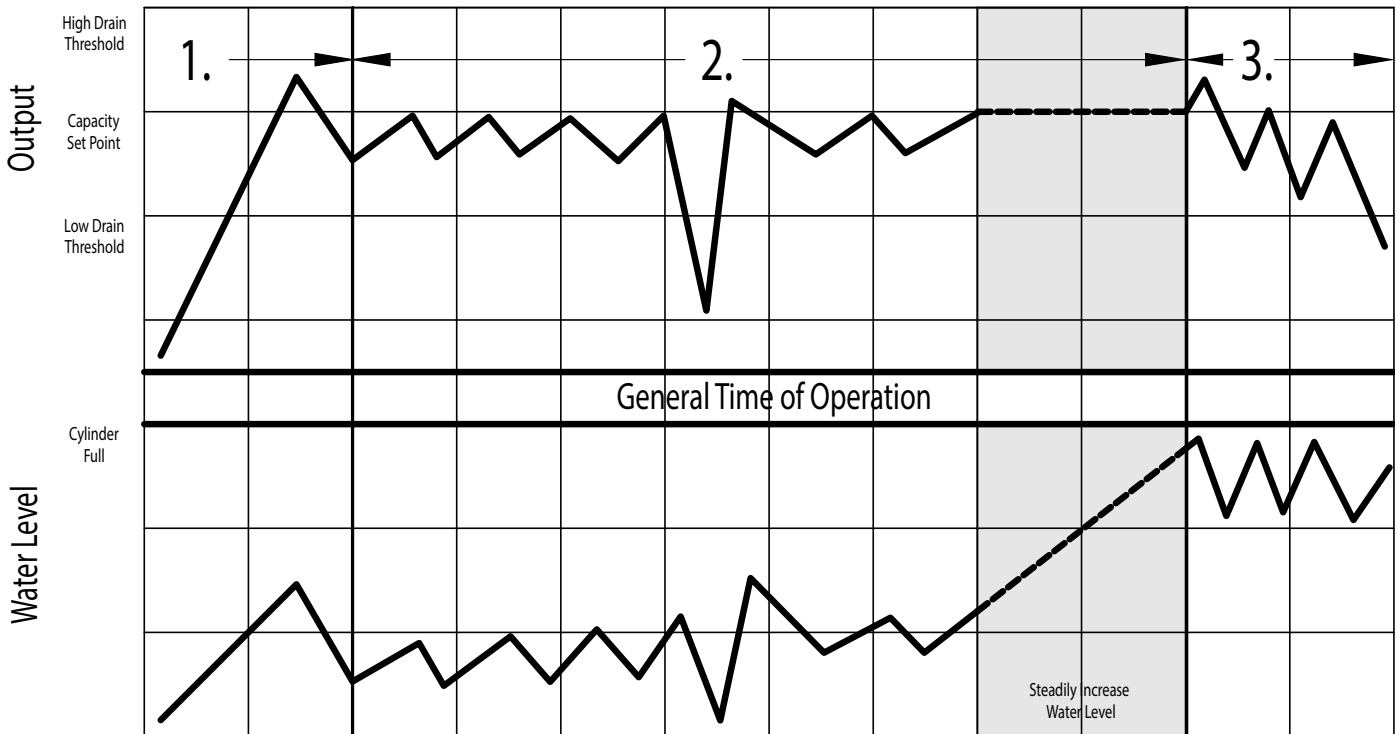

Key Features

Adjustable Setpoints (See Figure 7, Page 11)

Capacity

- Range = 50-100%
- Preset at 100% for 6000-1
- Preset at 50% for 6000-2

Low Drain Threshold

- Range = 50-100%
- Preset at 90%

Cycle Time

- Range = 30-180 seconds
- Preset at 60 seconds

Faults:

Overcurrent

- 138% of Rated Current
- System Shutdown

Fill System

- Fill valve open for 6 hours without achieving capacity setpoint or cylinder full
- System Shutdown

End of Cylinder Life

- 6 hours of operation while on cylinder full without achieving capacity setpoint.
- System Shutdown
- **Operation using water of less than 100 micromho is not recommended.**
- **Typically 500-2000 hours of cylinder operation can be obtained. Your actual cylinder life may be higher or lower depending on the exact composition of your water supply.**

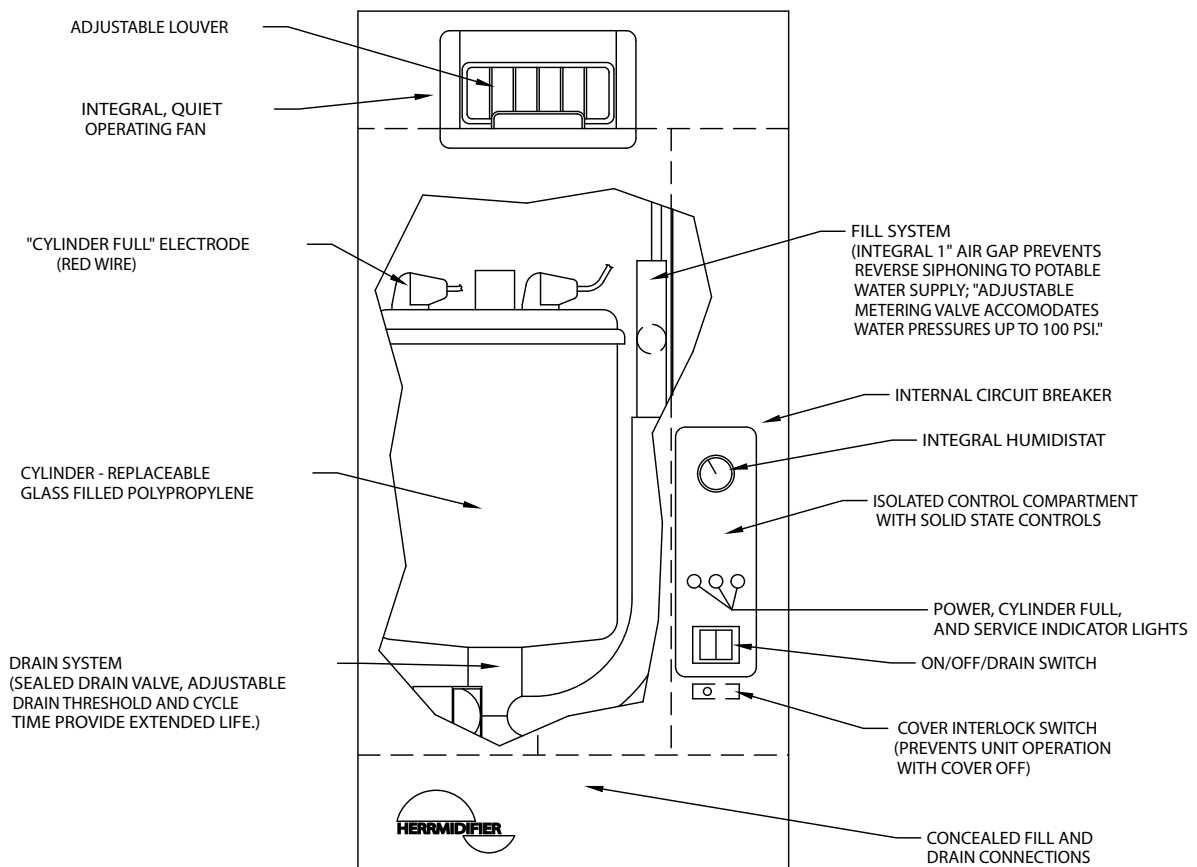

Engineering and Application

The Herrtronic 6000 Series Steam Humidifiers can be applied in a variety of applications. The simplest application is to utilize the model with the built-in blower package. The steam generated by the unit is distributed into the conditioned space by the built-in blower package (Figure 1).

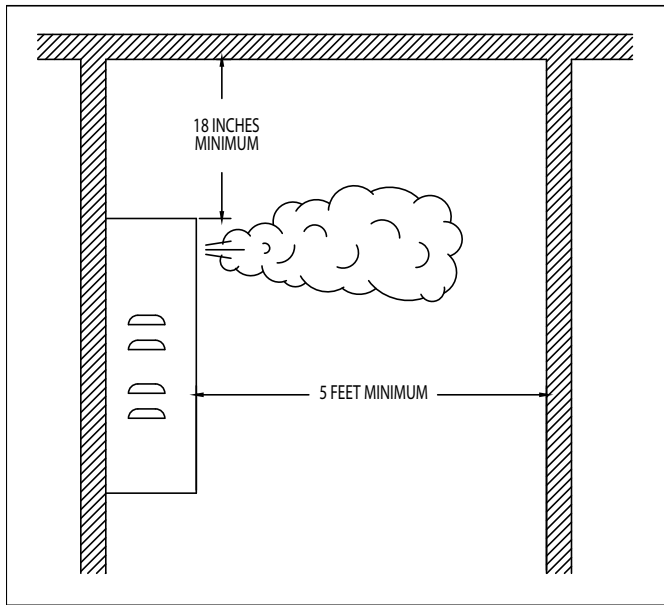

Figure 1

Allowable Operating Conditions:

- Ambient Temperature: 40°F (4°C) to 120°F (50°C)
- Ambient Relative Humidity: 0% to 90% (non-condensing)
- Line Voltage: -15% to +10% of Nominal
- Frequency: 50/60 HZ.
- Water Supply Pressure: 20 psi – 100 psi.

SECTION III INSTALLATION INSTRUCTIONS

Mounting

The cabinet is designed to safely contain the working components of the Herrtronic 6000 series humidifier and dissipate heat to protect the electronics. Locate humidifier in a manner to allow routine inspection and any necessary maintenance. DO NOT install the unit above false ceilings or around valuable property, where a malfunction could cause damage. Correct positioning of the humidifier is important to allow for proper operation and easy maintenance. Minimum clearance around the cabinet should be maintained as follows:

Minimum Clearances Around Cabinet	
Left	6"
Right	12"
Top	18"
Bottom	12"

Remove foam packing from top of cylinder. Four lag bolts, (2) 5/16" and (2) 1/4", are supplied with the 6000 unit. Install the top two lag bolts (5/16") according to the dimensions in Figure 2. Hang the unit on the wall, and then install the bottom two lag bolts (1/4") and secure all four bolts. Be sure the unit is level and mounted directly to the wall to wood studs at least 2" thick (or equivalent). Operating weight: 35 lbs.

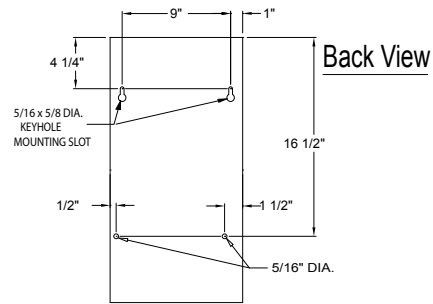

Figure 2

WARNING!

Do not mount any controls inside the unit or tap power from any location in the unit, except as stated in these instructions. Do not place objects near the cabinet. Do not attach to dry wall without studs. At least one 5/16" and one 1/4" lag bolt must be located on a stud.

Installation, Operation, & Maintenance Manual

Plumbing

To make the necessary connections for water fill and drain, the following steps are required: (refer to Figure 3 for locations)

1. Install external shutoff valve between the water supply and the humidifier for ease in servicing the unit.
2. Connect water supply to the 1/4" compression fitting on the bottom of the cabinet.

CAUTION!

Do not use reverse osmosis or demineralized water treatment without first consulting the factory. This water may not be sufficiently conductive to allow proper operation. Consult factory if water is outside the range of allowable conductivities. Do not use hot water.

3. Connect the 3/4" tube from the accessory pack to the drain reservoir. Cut the tube to the length necessary to reach the drain.
4. Insert the other end of the tube into a minimum 6" vertical length of the 1-1/4" minimum I.D. drain line. The balance of the drain line should be 1" I.D. minimum with a minimum 1/8" per foot slope. (See Figure 3.)

WARNING!

If the drain line is exposed, it is recommended that it be insulated for safety. Do not use PVC drain line unless "Drain Tempering" is enabled.

NOTE:

Inlet water pressure must be in the range of 20-100 psig. Consult the factory if you are outside this range. Softened water may be used but requires that the low drain threshold be adjusted. Drain water can be tempered to lower its temperature.

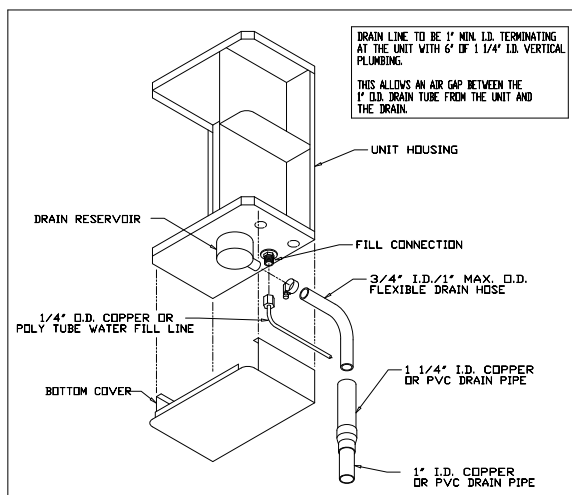

Figure 3

Steam Distribution

The 6000 Series Steam Humidifier with the built-in blower pack should be mounted a minimum of 18" from the ceiling. There should also be 5 feet of horizontal clearance in front of the unit to prevent steam from condensing on obstructions (See Figure 1). There is an adjustable louver to adjust the direction of the steam plume.

WARNING!

Do not adjust this louver to extreme angles as it will restrict the airflow causing condensation to form around the steam distribution manifold.

WARNING!

Locate away from areas where people can walk into the steam path.

Wiring

All field wiring should be routed up through the knockout in the bottom panel or in the back of the unit.

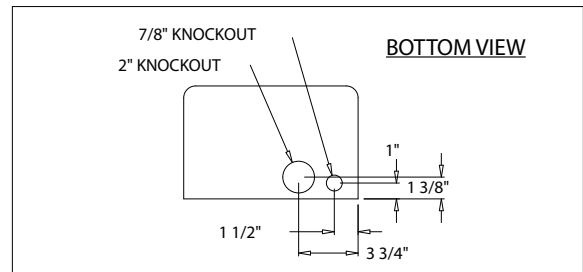

Figure 4

Supply Power

1. Ensure that minimum circuit ampacity is 15 amps.
2. Terminals are provided in the electrical compartment for field connection of the main power supply legs (single phase) and a ground wire.
3. Install external overcurrent protection and provide wiring in accordance with the NEC, state and local codes.
4. Power supply must be "clean": free of spikes, surges and sags: -15% to +10% of nominal.

Electrical Characteristics

Capacity	Steam Output	
	Lbs. / hr	4
Kg / hr	1.8	3.6
Input KW		
	1.33	2.66
Volts/Ph: Amps		
120/1	11.8	N/A
230/1	5.9	11.8

Control Circuit Connections

WARNING!

Do not install any controls inside the Herrtronic 6000 cabinet. Installations of any extraneous devices inside the electrical compartment may cause erratic behavior of the circuitry and will VOID the warranty.

The 6000 units with built-in blowers require no external control wiring since the humidistat is built-in.

SECTION IV OPERATING INSTRUCTIONS

Start-up Instructions

1. Check that the humidifier is properly mounted and level.
2. Check that the water fill and drain are properly connected.
3. Check that the correct voltage and amperage service are supplied.
4. With power off, double check all electrical connections and plumbing connections to ensure that they did not loosen during shipment.
5. With the "on-off-drain" switch in the "off" position, and the control humidistat at its lowest setting, turn on the main disconnect. The contactor should remain deenergized and the power light should remain "off". Place the "on-off-drain" switch in the "on" position and the power light should illuminate.
6. Turn the control humidistat up to its highest setting. The contactor should pull in.
7. After approximately a 5 second delay, the fill valve energizes and water begins to fill the cylinder to the preset amp level or cylinder full condition, depending on the incoming water supply. When starting up the unit, it is best to put an amp clamp on the power leg that passes through the toroid transformer. Ensure that the humidifier fills to "cylinder full" (approximately 1.5" from the top of the cylinder), or that the amperage reaches the data plate maximum and the fill valve de-energizes.

NOTE:

If upon initial start-up of this humidifier the cylinder is slow in heating and/or the service light continues to come on, drain the cylinder to 1/4 full. Turn off power at breaker, obtain some Alka-Seltzer tablets and crumble 1/2 of one tablet (Alka-Seltzer) into the grey fill tee. Change the middle blue dial on the left side of the circuit board, R18, from 90% to 87%. Then turn the breaker on and run the unit. If you have had to use these this step on a 240V unit (6000-2,4), it is advisable that you order a GT-176-1 replacement cylinder rather than the standard replacement cylinder in the future so this procedure will not need to be repeated. Upon receipt of the GT-176-1 cylinder, adjust the dial, R18, on the circuit board back to 90%.

8. All units are equipped with a drain tempering feature which mixes cold fill water with the hot drain water to protect drain piping. Depending on your fill water pressure, some adjustment of the fill metering valve may be necessary to ensure drain water of less than 140°F. (See Figure 5.) To deactivate, remove diode from socket CRI8 from circuit board. (See Figure 7.)
9. Reset control humidistat to its desired settings. Typical control humidistat settings are 30-40%.

NOTE:

The capacity of the humidifier can be adjusted between 50% and 100% of the maximum level by adjusting the capacity adjustment potentiometer (labeled R39) on the main circuit board. All units are set from the factory to produce 4 lbs/hr. If the psychrometric conditions permit, the 6000—2 may be increased to 8 lbs/hr by adjusting R39 from 50% to 100% capacity. Refer to Figure 7.

CAUTION!

Inadequate airflow may allow humidity to collect in areas causing condensation.

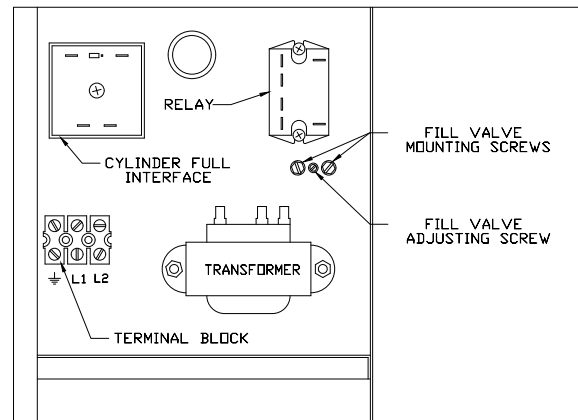

VIEW IN FROM RIGHTSIDE OF UNIT
Figure 5

Installation Checklist

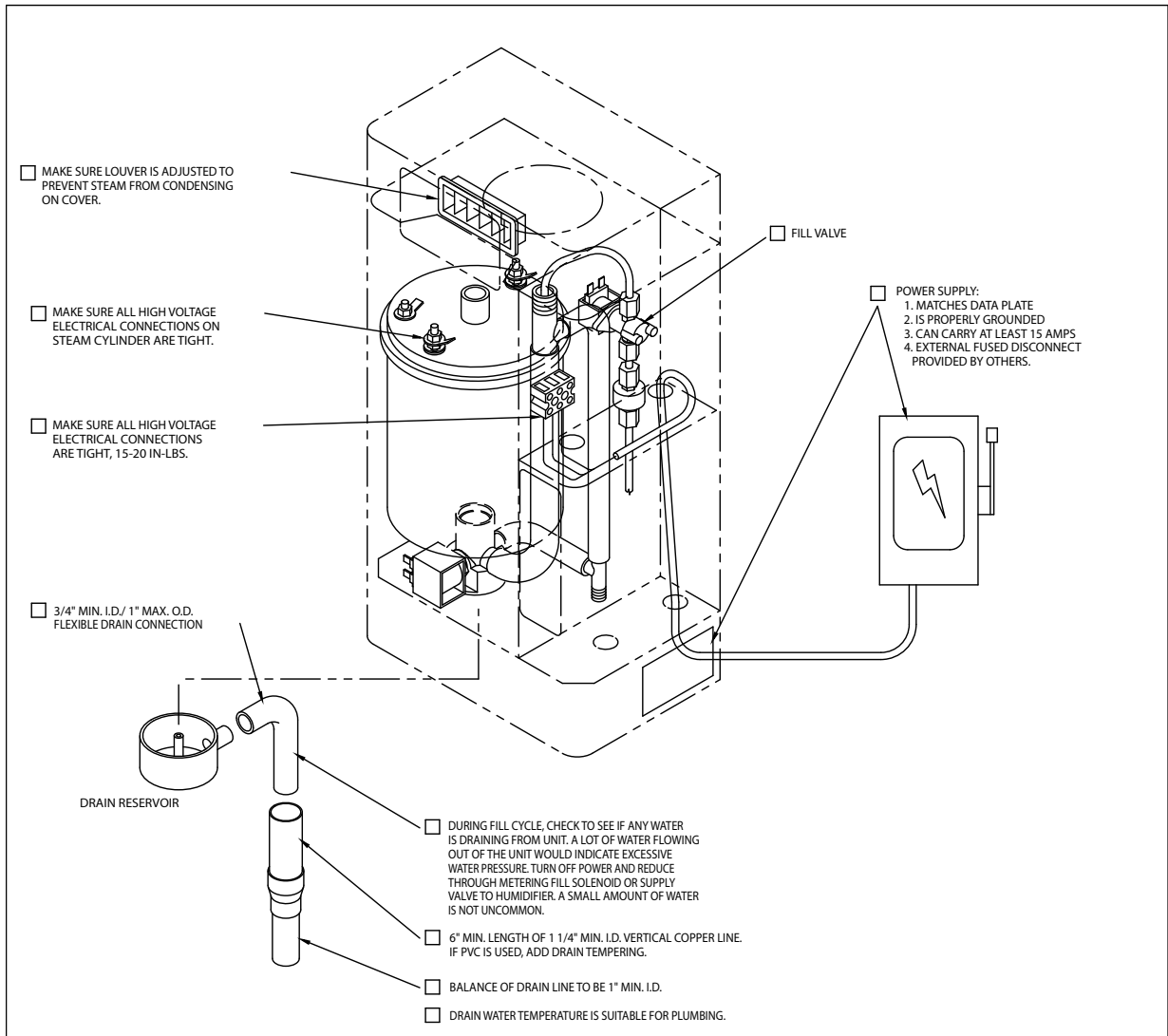

NOTE:

The Herrtronic 6000 Humidifier checklist is provided to help the installer ensure a successful installation. If further assistance is needed from the TRION/HERRMIDIFIER representative or the factory, the checklist is expected to be completed. If a job site visit is required from the TRION/HERRMIDIFIER representative or the factory, and the checklist has not been accurately completed, additional charges may be applied by the individual(s) representing TRION/HERRMIDIFIER. If the visit uncovers a component malfunction, the parts will be replaced under warranty.

Project Name

Checklist completed by

Humidifier Installer (Company)

Checklist completion date

Maintenance

To maintain output, the water level in the cylinder will slowly move upwards, exposing new electrode to the water as the electrodes become coated with minerals. Eventually, all of the usable electrode surfaces will be coated and the cylinder will be full of water. At this point, the output will begin to drop and the red "service" light will come on. The unit will shutdown. This indicates the need to change the cylinder, typically 500-2000 hours of operation, depending on the quality of the fill water supply.

To replace the cylinder

1. Drain cylinder completely using the 'on-off- drain" switch.
2. Turn off power to the unit at the external disconnect. Disconnect electrode power wires (#38 & #39) and cylinder full electrode wire (#29) from the cylinder. These connections are 1/4" quick connects. (See Figure 6B, 6C, & 6D.)
3. Disconnect 1" hose at top of cylinder.
4. Remove cylinder, clean out the drain cup and insert the new

cylinder. Be sure that "o" ring is in place on the cylinder fill/ drain port prior to installation. (See Figure 6A.) New o-ring is included with each replacement cylinder.

5. Clean and check both the fill and drain valves while servicing the unit.
6. Check the strainer. If it is dirty or restricting the water- replace it.
7. Install cylinder in unit by pushing downward with a slight twisting motion, while ensuring proper orientation of cylinder within cabinet.
8. Reconnect electrode power wires (#38 & #39) and cylinder full electrode, wire (#29). Make sure that all electrical connections are securely tightened. (See Figures 6B, 6C, & 6D.)
9. Follow cold start-up instructions on page 8. Monitor amp draw for several cycles.

Extended Shutdown

Always drain cylinder completely if unit will be off for an extended period of time. This will preserve the life of the cylinder.

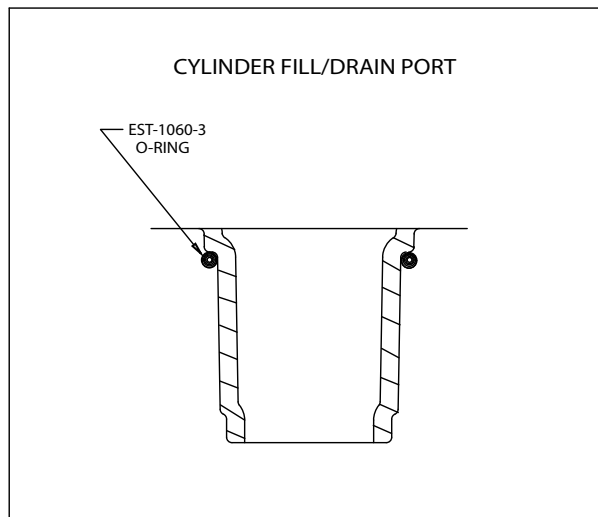

Figure 6A

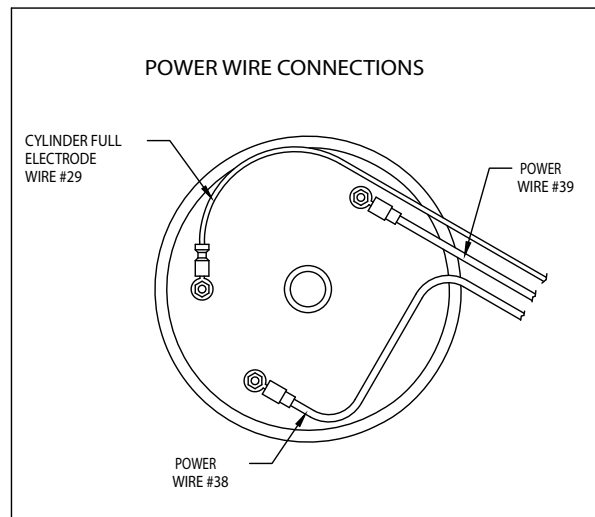

Figure 6B

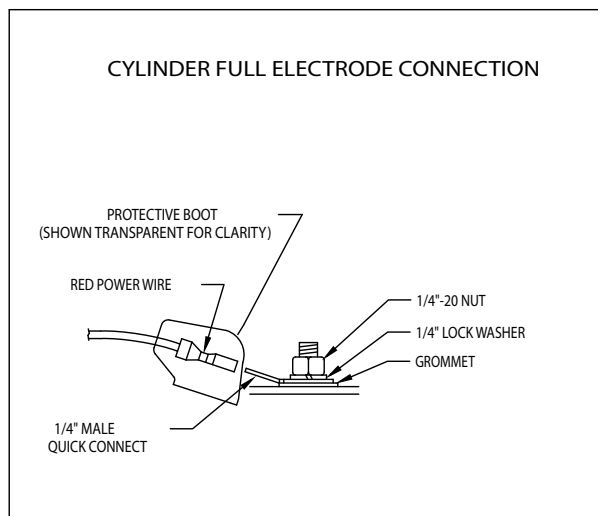

Figure 6C

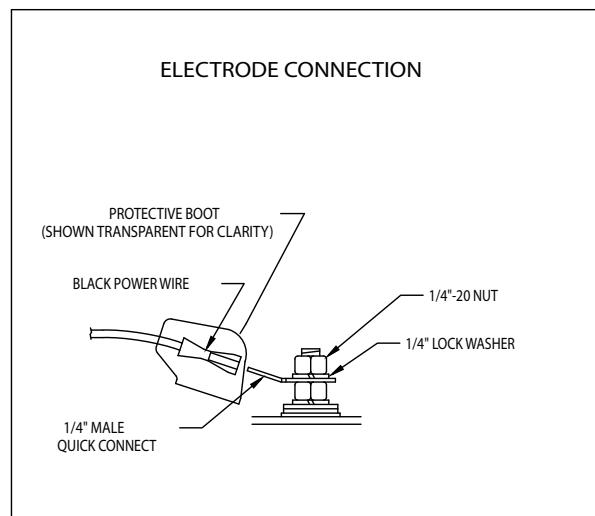

Figure 6D

SECTION V TROUBLESHOOTING GUIDE

All Herrtronic 6000 Series Humidifiers are manufactured under strict quality control and are subjected to a complete operational test before shipment. All circuit board adjustments are made at the factory and should not be adjusted beyond the guidelines set in this troubleshooting guide without first consulting a factory representative. The following information is for your help and reference. If you still experience difficulty after trying these remedies, contact your TRION/HERRMIDIFIER representative.

WARNING!

The Herrtronic 6000 Series Electronic Steam Humidifier cabinet was designed to house and shield the components from outside interference. Absolutely NO other components may be mounted inside or be electrically tapped into the humidifier without TRION/HERRMIDIFIER's express written permission. Failure to heed this warning will void your warranty.

TEST POINTS

Each circuit board (See Figure 7) features three test points to aid in the troubleshooting process. Each of these test points works on a 0-4 VDC scale. "0 VDC" = 0%. "4 VDC" = 100%. All readings are between the test point and ground (Molex J1, terminal 11 [far right of molex connector, wire #11]).

Test Point #1:

Provides exact reading of drain threshold setting.

Test Point #2:

Provides circuit board reference voltage. Should always read 4 VDC +/-2%.

Test Point #3:

Provides actual percentage of output. For example, a unit running at 80% of maximum output would have a Test Point #3 to ground reading of 3.2 VDC.

Maximum Capacity Setpoint

The potentiometer labeled "R39" located in the top left-hand corner of the board allows adjustment of the unit's capacity in the range of 50-100% of maximum.

Circuit Board Settings

Models	Time Cycle R23	Low Drain Setting, R18	Capacity, R39
Standard Settings			
All	60 sec	90% at 3.6V	100% at 4V
High Conductivity Settings (> 1000 micromho)			
All	84 sec	93% at 3.72V	90% at 3.6V
Softened Water Settings (750-1000 micromho)			
All	60 sec	92% at 3.68V	95% at 3.8V
Low Conductivity Settings (<100 micromho)			
All	60 sec	85% at 3.4V	100% at 4V

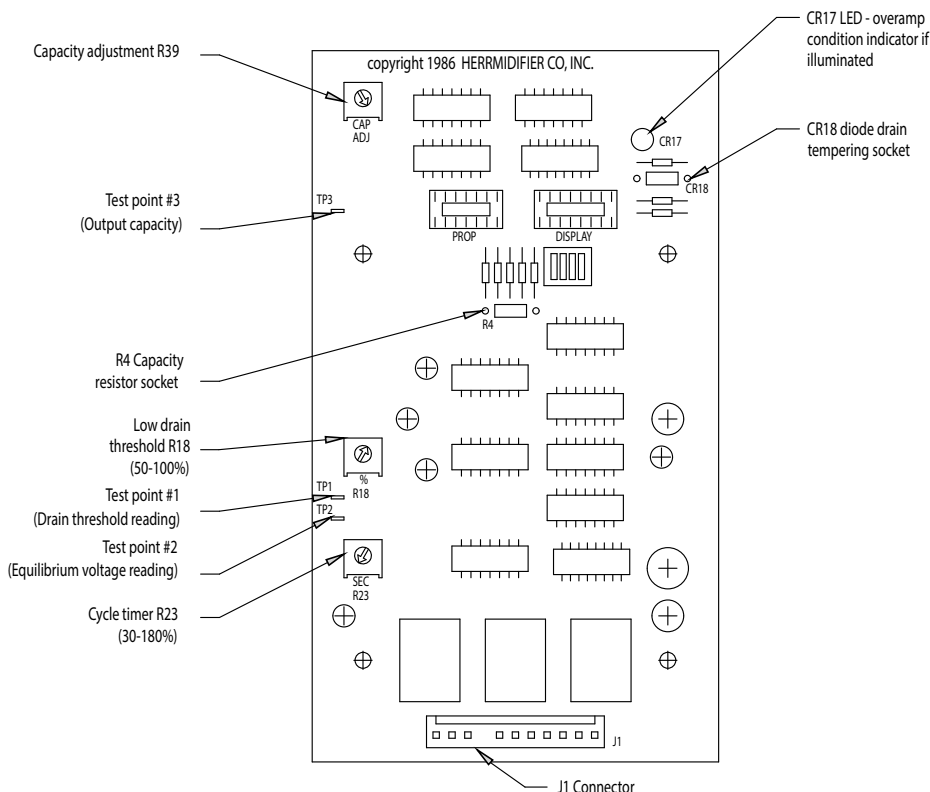

Figure 7

Unit Detected Faults: (Red Service Light is ON)

Problem / Symptom	Probable Cause	Reason - Correction
Overcurrent The alarm condition occurs when an overcurrent situation (>138% of rated current) has occurred and the humidifier has shut down to prevent any damage. This alarm indicates that there has been a significant reduction in resistance between the main legs of the supply power and the humidifier has been shut down to prevent damage and should be serviced before it is restarted. Overcurrent LED CR 17 (Figure 7) is illuminated.	Dead short between electrodes.	Replace the steam cylinder. Check resistance between electrodes with power "off"
	Restricted or blocked drain.	Clean and inspect drain system.
	Restricted fill system	Clean and inspect the fill system. Check for restriction or loss of supply pressure.
	Incoming water conductivity is outside the range of normal circuit board settings.	Consult the factory for options.
	Check amp draw to unit during start-up. If amp draw greatly exceeds rated amp draw, the drain threshold pot, labeled "% adj." (R18), must be increased 2% to increase the frequency and duration of drains to reduce the conductivity inside the cylinder.	Manually drain the unit and restart.
End of Cylinder This alarm condition occurs if the humidifier is unable to reach full output over a 6 hour timeframe. It is constantly switching between "fill" and "cylinder full" modes. This alarm indicates a need to change the cylinder, that the water supply is low in conductivity, or that a foaming condition exists:	End of cylinder life – Cylinder life is typically between 500 and 2000 hours, depending on incoming water supply.	For emergency use, you may restart the humidifier with the capacity setpoint, R39, at a lower level to allow operation until a replacement steam cylinder can be obtained. To clear the fault, turn the main disconnect to the unit "off" and then back "on".
	If incoming water supply is less than 100 micromho, the unit may not be able to pass the rated current through the water.	See – NON-FAULT ACTIVATED PROBLEMS GUIDE – "Unit fills to the cylinder full condition and remains cold"
	Foaming condition exists.	Flush and fill the steam cylinder several times and restart. If it persists, you must filter or treat the water to remove the foaming agent. See circuit board settings on previous page if supply water is softened. See NON – FAULT ACTIVATED PROBLEMS GUIDE – "Water foaming inside the cylinder"
Fill System Fault This alarm condition occurs when the fill valve has been energized for a 6 hour timeframe. The humidifier has been shutdown to prevent any damage.	Loss of or restricted water supply	Check fill system.
	Leaking drain system.	Check drain system.
	Defective drain valve.	Repair and replace as required.
	Defective fill valve.	Repair and replace as required.

NOTE: The three fault conditions outlined above will cause the humidifier to shut down and the service light on the front of the unit to illuminate. To clear these faults, the main power must be turned "off" and back "on" again.

Installation, Operation, & Maintenance Manual

Non-Fault Activated Problems:

Problem / Symptom	Reason - Correction
24 VAC circuit breaker trips as soon as power switch is turned "on".	Check the wiring at the 24 VAC breaker for a short or loose connection.
	Disconnect the contactor coil from the circuit and repeat. If 24 volt breaker doesn't blow, replace the contactor.
	Replace the main circuit board.
24 VAC circuit breaker trips after the unit is turned on for about 15 seconds.	Disconnect fill valve from electrical circuit. If circuit breaker doesn't trip, replace the fill valve.
	Replace the main circuit board
24 VAC Circuit breaker trips whenever the drain valve activates	Disconnect drain valve from electrical circuit. If circuit breaker doesn't trip, replace the drain valve.
	Remove the drain valve and ensure that it is clean and free of any obstructing mineral deposits.
	Replace the main circuit board.
Humidifier turned on but will not operate. Power lamp is "off".	Check power supply.
	Check circuit breaker.
	Check connector J1 on the circuit board and ensure that it is plugged into the circuit board properly and that no wires are loose.
	Ensure that there is 24 VAC between pole #9 and #11 connector J1. If not, check wiring.
	Check door interlock.
Unit turned "on". Contactor pulled in, but no water is entering the cylinder.	Check external shutoff valves and open if closed.
	Check strainer and fill valve for clogs. Turn adjusting screw (Figure 5, page 8).
	Check fill valve coil to determine if it is receiving 24 VAC. If so, replace the valve.
	Check for break in wiring.
Excessive arcing in cylinder	Check drain valve and ensure that when it activates it drains freely. Clean if necessary. Replace valve if defective.
	Check water supply. If it is softened, increase the drain threshold pot, "% adj." (R18), up to 92% at 3.68VDC. (See Figure 7, page 11.)
	Use high conductivity settings if water supply is very hard, >750 micromho.
	Unit filling slower or at the same rate as the water is boiling, causing over concentration and foaming. Check restriction in fill line. Adjust the metering fill valve to allow greater flow of water. (See Figure 5.)
	Have water analyzed. If iron content is greater than .1 mg/liter, a filter will have to be used.
	Consult factory with water analysis
Unit fills to the cylinder full condition and remains cold.	Check between Test Point #3 and ground with a multimeter set on VDC scale. Confirm the circuit board is seeing low current flow (<2.8 VDC). Proceed to next step.
	If on initial fill, unit reaches less than 70% of rated capacity (2.8 VDC on Test Point #3), adjust the drain threshold pot, "% adj." (R18), down 2-3%. Manually drain the unit down completely and add ½ Alka Seltzer tablet via the fill tee(GT-120). Restart the unit while monitoring the amp draw. Fill unit ¼ full and turn "off" for several minutes to allow tablets to dissolve. Restart unit. If amperage rises rapidly, it may be necessary to dilute the water. If amperage rises slowly, add another Alka-Seltzer tablet.
	Check that drain valve is sealing properly.
	Check the water conductivity and consult the factory.
Unit turned on and cycles for a short period of time. Then it stops in the middle of a fill cycle and won't reset until boiling stops.	Check cylinder fill interface connections.
	Check cylinder connections. (See Figures 6A-6D, page 10.)
	Check items in next troubleshooting tip concerning foaming.
	Check amperage between cylinder full electrode and cylinder full interface terminal #1. If it is greater than 7.0 mA AC, take a fill water sample and consult the factory.

Installation, Operation, & Maintenance Manual

Problem/Symptom	Reason - Correction
Water "foaming" inside the cylinder.	Check drain valve and ensure that water drains freely. If necessary, clean or replace valve if defective.
	Check water supply. If it is commercially softened, either increase the drain threshold (R18) to 92% or reconnect the unit to raw water. Drain and restart the unit. If the unit is connected to a hot water line, reconnect to the cold water line. (3.68VDC)
	If steam line is hard copper, drain cylinder and test unit operation disconnected from steam line to ensure flux from solder joints is not causing foaming.
	Observe the fill tee(GT-120). If water is going down the overflow and the water level is low: Check to ensure that static pressure in the duct is not forcing water down the overflow instead of allowing water to enter the cylinder. Adjust the fill metering valve to regulate the water flow to the cylinder. (Figure 5.) Unit filling slower or at the same rate as it is boiling off, causing over concentration and foaming. Fill rate must be increased. Open metering valve. If the fill valve is already fully open, get a water analysis and consult the factory.
Cylinder fills and overflows	Check cylinder wiring. (See Figures 6A-6D, page 10.)
	Check wiring of cylinder full interface.
	If more than 1.9 mA AC is passing between the cylinder full electrode and interface terminal #1, and when placing multimeter between terminal #3 and ground yields approximately negative 11 VDC, replace the interface.
	Replace the circuit board.
Unit turned on, fills to full amp draw, stops filling, and after a delay, the circuit breaker trips and the service light comes on.	Consult the factory after obtaining a water analysis
	Use the "On-Off Drain" switch to drain the cylinder. Turn the capacity adjustment pot(R39) on the main circuit board to 80% and restart the humidifier. (3.2VDC)
	Check the drain valve and clean or replace if necessary.
Unit cycle "on" and "off" rapidly	If the drain valve doesn't come on before the service light illuminates, replace the main circuit board.
	Check location and setting of high limit humidistat
Cabinet leaks	Check for loose connections
	Fill tube out of fill tee
	Steam cylinder out of drain cup
	Cabinet drain backing up, kink in drain line

WIRING DIAGRAM

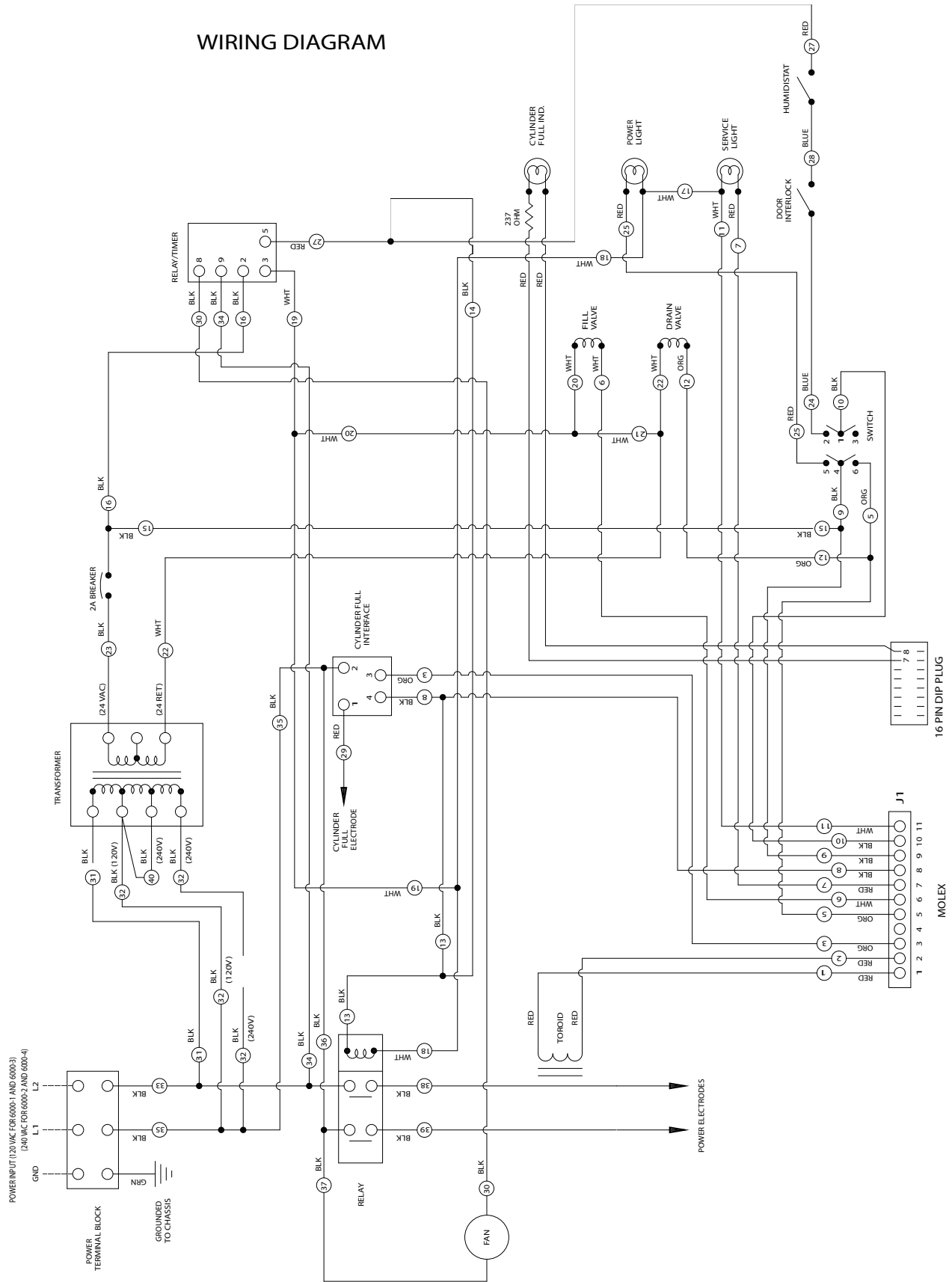

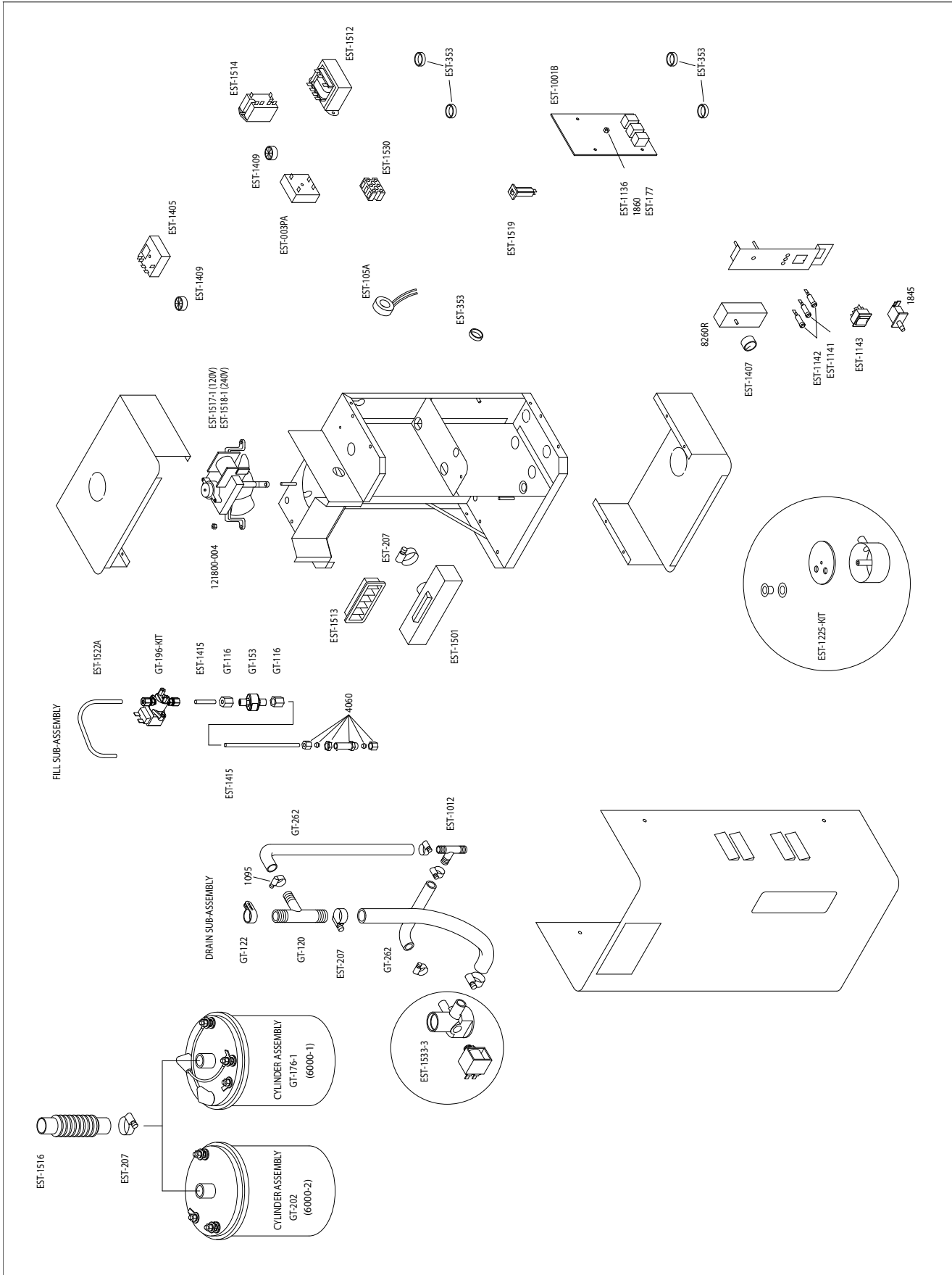

Parts List

1095	Hose Clamp SS
1845	Door Interlock
1860	KEP Nut, 6-32
4060	Fitting, 1/4" Bulkhead
8620R	Humidistat Element
121800-004	KEP Nut, 8-32
EST-003PA	Cylinder Full Interface
EST-105A	Toroid Transformer
EST-177	Nylon Spacer
EST-207	Clamp
EST-353	Bushing
EST-1001B	Main Circuit Board
EST-1136	Nylon Washer
EST-1141	Red Lamp
EST-1142	Green Lamp (2)
EST-1143	On Off Drain Switch
EST-1225-KIT	Drain Reservoir Kit
EST-1405	Timer/Relay
EST-1407	Knob
EST-1409	Universal Bushing
EST-1415	Tubing
EST-1501	Steam Manifold
EST-1512	Transformer 120/240 to 24 VAC
EST-1513	Distribution Louver
EST-1514	Relay, 2 pole, 20 A
EST-1516	Steam Hose
EST-1517-1	Fan, 120V
EST-1518-1	Fan, 240V
EST-1519	Circuit Breaker, 2A
EST-1522A	Fill Assembly
EST-1530	Terminal Block
EST-1533-3	Drain Valve Kit
EST-1542	Power Wire Assembly (Not Shown)
GT-116	Celcon Compression Nuts
GT-120	Fill Tee
GT-122	Nylon Clamp
GT-153	Strainer SS
GT-176-1	Low Conductivity Steam Cylinder Assembly (Standard 120V Units)
GT-196-KIT	Fill Valve Replacement Kit
GT-202	Steam Cylinder Assembly (Standard 240V Units)
GT-262	Hose, 1/2" I.D. Overflow



TRION®

101 McNeill Rd. | Sanford, NC 27330

P: 800.884.0002 | F: 800.458.2379 | www.trioniaq.com | customerservice@trioniaq.com