

This Owner's Manual is provided and hosted by [Appliance Factory Parts](#).



TRION T1300 Air Boss Owner's Manual

[Shop genuine replacement parts for TRION T1300 Air Boss](#)



[Find Your TRION Air Cleaner Parts - Select From 28 Models](#)

----- Manual continues below -----

TRION[®]

Indoor Air Quality



T1001 Module
T2002 Module
T1300
T2600

READ AND SAVE THESE INSTRUCTIONS

Air Boss[®] T-Series
Custom Packaged
Electronic Air Cleaner

Electrostatic Precipitators for Commercial & Industrial Applications

Air Boss® T-Series

Air Treatment Systems

Table of Contents

Specifications	2
Preparation for Installation	3
New Unit Inspection.....	3
Operation.....	3
How It Operates.....	3
Unit Operation.....	3
Ducting Application.....	4
Installation	4
Liquid Aerosol Installation.....	5
Electrical Installation.....	5
Maintenance	5
Cleaning.....	6
Inspections.....	6
Replacement Parts Ordering	6
Warranty	7
Troubleshooting Guide	7
T1001/T2002.....	7
T1300/T2600.....	7
Troubleshooting Diagram.....	8
Diagrams/Exploded View Figures	9
Figure 1 - T1300 Unit.....	9
Figure 2 - T2600 Unit.....	10
Figure 3 - T1001 Unit.....	11
Figure 4 - T2002 Unit.....	12
Figure 5 - Enclosure Assembly.....	13
Figure 6 - Blower Assembly.....	14
Figure 7 - Ionizer/Collector Cell.....	15
Figure 8 - Blower Curves.....	16
Figures 9-12 - Wiring Diagrams.....	17

Specifications

Power Requirements			
Model	Voltage	HP	AMPS (Max)
T1001 Module	120V, 60 Hz, 1 PH.	-	0.4
	230V, 50 Hz, 1 PH.	-	0.2
	230V, 60 Hz, 1 PH.	-	0.2
	230V, 60 Hz, 3 PH.	-	0.2
	460V, 60 Hz, 3 PH.	-	0.1
T2002 Module	120V, 60 Hz, 1 PH.	-	0.5
	230V, 50 Hz, 1 PH.	-	0.3
	230V, 60 Hz, 1 PH.	-	0.3
	230V, 60 Hz, 3 PH.	-	0.3
	460V, 60 Hz, 3 PH.	-	0.2
T1300	120V, 60 Hz, 1 PH.	3/4	11.2
T1300A	230V, 60 Hz, 1 PH.	3/4	5.6
T1300B	230V, 60 Hz, 3 PH.	1	3.6
T1300C	460V, 60 Hz, 3 PH.	1	1.8
T1300D	575V, 60 Hz, 3 PH.	1	1.6
T1300E	230V, 50 Hz, 1 PH.	3/4	5.9
T1300N	208V, 60 Hz, 3 PH.	1	3.6
T2600	120V, 60 Hz, 1 PH.	3/4	11.3
T2600A	230V, 60 Hz, 1 PH.	3/4	5.7
T2600B	230V, 60 Hz, 3 PH.	1	3.7
T2600B	230V, 60Hz, 3 PH.	2	6.5
T2600C	460V, 60 Hz, 3 PH.	1	1.9
T2600C	460V, 60 Hz, 3 PH.	2	3.3
T2600D	575V, 60 Hz, 3 PH.	1	1.7
T2600E	230V, 50 Hz, 1 PH.	3/4	6.0
T2600N	208V, 60 Hz, 3 PH.	1	3.7
T2600N	208V, 60 Hz, 3 PH.	2	6.5

Notes

Ionizer Voltage: 12 KVDC

Collector Voltage: 6 KVDC

Motor (where applicable): Ball bearing, totally enclosed, fan cooled

Preparation for Installation

This manual should be carefully read before starting the preparation and installation of the air cleaner.

The installation should conform to all local ordinances associated with building codes and electrical codes required for the unit. Authorities having jurisdiction should be consulted before installation is made. If there are no local codes, the installation should conform to the National Electrical Code.

SAFETY NOTE

Factory designed access to all electrically charged high voltage components contain electrical interlocks for the safety of operating personnel. Any additional access that may be provided in the system, where there is access to high voltage, must be equipped with such interlocks. Interlocks are readily available from the factory.

The 575V, 3 Phase unit does not have internal motor overload protection. The installer must provide overload protection in accordance with National Electrical Code, Canadian Electrical Code, Part 1 or other applicable electrical codes.

For maximum air cleaning efficiency, your air cleaner should be located as specified by your TRION representative.

The unit can be either wall-mounted or chain-hung. Trion can supply eyebolts.

New Unit Inspection

Immediately, upon receiving the unit, carefully examine the package for damage during transit. If the unit is damaged, contact the last carrier for claim filing and contact your TRION representative.

While unpacking the unit, look for concealed shipping damage. If there is damage, it should be reported to the last carrier for claim filing.

Operation

What is Your Electronic Air Cleaner?

Your air cleaner is a high efficiency contaminant collector designed to remove up to 95% of the dust, smoke, liquid aerosol and other pollutants from the air passing through it.

How It Operates

Polluted air is drawn into the unit by the belt driven blower on a T1300 or T2600 unit. The T1001 and T2002 units require an external air handler to move the air.

After passing through a pre-filter, the particles in the air are given an electrical charge supplied by the power supply. As the particles enter the collector cells, these charged particles are attracted to and collected on grounded collecting plates.

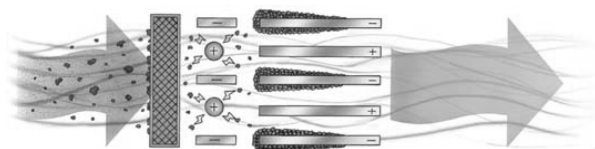

Typical Electronic Cell Operation

Unit Operation

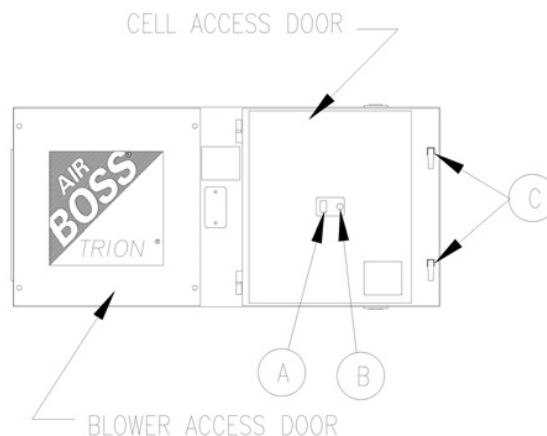

Control Switch (A): The control switch is located on the cell access door. It controls the operation of the power pack (and the belt driven blower on the T1300 and T2600). The control switch should be in the "OFF" position when the cell access door is open for maintenance of the unit.

Indicating Light (B): The light located adjacent to the control switch is an indicator of the performance of your electronic air cleaner. When the control switch is “ON”, the blower should operate on the T1300 and T2600, and the indicator light should glow. If the light does not glow or if it continually flickers and is accompanied with a continual snapping or arcing noise, the air cleaner requires attention and may need to be cleaned.

Cell Access Latches (C): The cell access latches are located on the door near the intake end of the unit. To open the cell access door, lift and turn the latches counter clockwise.

Arcing (snapping or cracking noise): An occasional arcing noise may be emitted from the air cleaner. This is a normal occurrence caused by exceptionally large pieces of dirt, etc., entering the collecting elements. In addition, an arcing noise accompanied by a flickering of the indicating light may be noticed after washing the cells. Should this occur, allow more drying time. Also, see “Troubleshooting Chart”, for additional causes of arcing.

The louvers on the grill are adjustable so the direction of airflow can be controlled as desired.

NOTE: The unit is equipped with an interlock switch for your safety. The unit will not operate if the cell access door is not closed securely.

NOTE: An interlock switch does not protect the blower access door on the T1300 and T2600. Do not attempt to operate the unit unless the door is fastened securely.

Ducting Application

The T1300 and T2600 air cleaners are designed for both free hanging applications and limited duct system applications. The duct systems must be carefully designed to keep the external static pressure to a minimum while still moving the required amount of air. Some added static pressure could be overcome by adjusting the blower drive pulleys or using a more powerful motor. Capture hoods and duct design information may be obtained from the Industrial Ventilation Handbook or from your local TRION representative.

To maintain the selected cleaning efficiency, it is important to assure that the total air volume (capacity in CFM or m³/hr) is uniformly distributed across the entire face area of the unit. The metal mesh filters, perforated plate or mist suppressors provide some resistance to effect even air distribution. However, since most air ducts are designed to handle air velocities greater than the rated velocity of the air cleaner, it is necessary to properly transition any attached ducting. If possible, a contraction ratio of 1 in 3 (approximately 20°) should be maintained. If space prohibits, turning vanes, air baffles or other means may be utilized. Ducting – where attached to the cabinet collars – should be gasketed, caulked or otherwise made watertight.

Installation

1. Carefully unpack unit from shipping crate or carton and examine for damage in shipment.
2. Remove ionizer/collector cell(s), pre-filters and after-filters.
3. Attach 500 pound (227 kg) test chain to the ceiling joist using:
 - a. Wood joist – 3/8” (m10) eye bolts
 - b. Metal joist – wrap chain around joist at least twice and secure with 500 pound (227 kg) test connecting link
4. Chain should be cut to allow the unit to hang from a predetermined height from the floor. (Usually 10-12 feet or 3.0-3.6 m).
5. The unit is equipped with a locator dimple in each corner on the top and bottom. Using the dimples as a guide, drill (4) 13/32” dia. (10.3 mm) holes that will be required for mounting the eyebolts, which are attached to the suspension chain.
6. Position a 3/8” (m10) diameter eyebolt (or larger) in each hole and secure with a washer and appropriate nuts. **NOTE:** Be sure to place two nuts on each eyebolt to act a locking nut. Failure to do so may cause the nuts to loosen and the unit to fall.
7. Using 3/8” (10 mm) connecting links, attach unit to chain. Use turnbuckles on diagonally opposite chains. **NOTE:** Foul threads on turnbuckles after leveling unit to ensure that the turnbuckle will not “back off” or loosen and cause the unit to fall.
8. The units can be suspended with the direction of

airflow from the right to left. If a left to right airflow is desired, the unit may be flipped over and the eyehooks installed in what was originally the bottom.

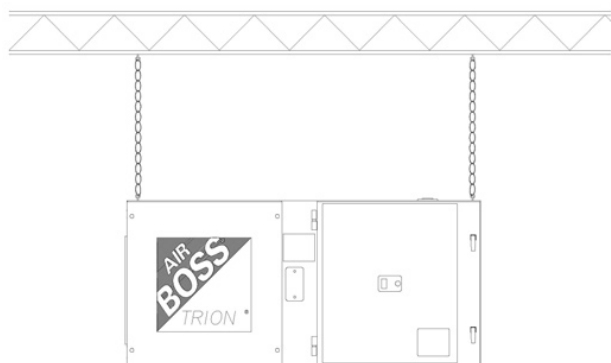

TYPICAL CHAIN SUPPORTED INSTALLATION

Liquid Aerosol Installations

The unit is equipped with a sump, drain hole sized to accept a 1/2" NPT fitting. For the collection of liquid contaminant:

1. Install drain fitting to allow for the attachment of a liquid collection cup or drain hose. A drain fitting is available from your representative. An "S" trap is required in the drain hose to ensure proper drainage of the collected liquid.
2. Raise the front corner of the unit, opposite of the drain corner, 1/2" (13 mm) to enable the collected liquid to flow to the drain sump.

Contaminants to be collected – such as oils in vaporous state – must be condensed into particulate form prior to entering the ionizing-collecting cells in order to maintain the anticipated efficiency. Gases, vapors or any non-particulate cannot be precipitated and will therefore pass through the air cleaner. Any condensing that takes place downstream from the air cleaner defeats the purpose. Similarly, heavy concentrations of water vapor, or other matter that becomes highly conductive when condensed, must be prevented from entering and/or condensing in the collecting elements to prevent electrical arc over and shorting.

Electrical Installation

All units must be wired directly in the junction box on the access door side of the unit. Use NEC Class I wiring

methods. Size branch circuit protection in accordance with the NEC. Refer to the appropriate enclosed wiring diagram in the attached figures.

WARNING
EXERCISE ALL THE NORMAL PRECAUTIONS WHEN WORKING WITH HIGH VOLTAGE AND COMPLY WITH NEC AND ALL APPROPRIATE LOCAL CODES.

Check Out for System Start-up

When the installation has been completed, assure that the equipment is ready for start-up by checking the following:

- All construction debris is removed from the ionizing-collecting cells, drain connections and ductwork.
- The drain line from the TRION drain basin is clear and completely connected to its point of termination.
- Supply line power is available and electrical wiring is completed to the junction box.

Maintenance

The following instructions are for use by qualified personnel.

WARNING
RISK OF ELECTRIC SHOCK
 These serving instructions are for use by qualified personnel only. To reduce the risk of electric shock, do not perform any servicing other than that contained in the operating instructions unless you are qualified to do so.

SAFETY NOTE
 Factory designed access to all electrically charged high voltage components contain electrical interlocks for the safety of operating personnel. Any additional access that may be provided in the system, where there is access to high voltage, must be equipped with such interlocks. Interlocks are readily available from the factory.

Cleaning

To maintain optimum collection efficiency, the pre-filters and ionizer/collector cells should be removed periodically and soaked in a solution of hot water and TRION Tridex detergent for 2 to 4 hours, rinsed thoroughly and then air dried completely before reinstalling in the unit.

The frequency of cleaning is dependent on the type of contaminant being collected. Liquid aerosol requires less cleaning while welding smoke may require more frequent cleaning.

NOTE

TRION Tridex Detergent is specially formulated for use with TRION electronic air cleaners. Use of other cleaners and detergents, not specifically approved by TRION, can cause possible failures in the unit and will void any and all warranties on our equipment.

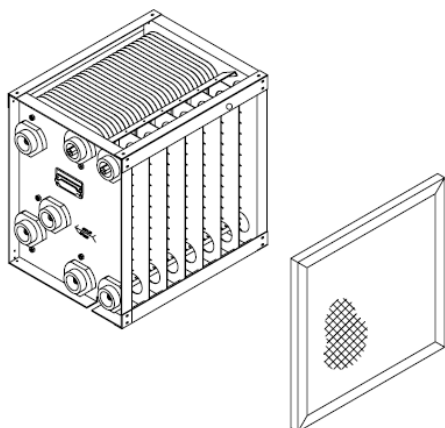

Wash Ionizing/Collecting Cells

WARNING

DO NOT USE HIGH PRESSURE STEAM CLEANING EQUIPMENT TO CLEAN CELLS. THE EXCESSIVE HEAT AND PRESSURE WILL CAUSE THE PLATES TO WARP AND IN TURN POSSIBLY CAUSE EXCESSIVE ARCING.

1. Turn the control switch "OFF" and disconnect power to the unit.
2. Open the cell access door.
3. Remove ionizer/collector cells and wash in HOT detergent water.
4. Remove the mechanical pre-filter. Remove collected dust or lint by vacuuming or brushing. Wash with warm, soapy water.
5. Rinse all components thoroughly in warm, clear water and allow to drip dry completely.
6. Replace pre-filters and ionizer/collector cells. ENSURE the airflow arrows point in the direction of airflow (towards the blower).
7. Close the access door; reconnect power to the unit.
8. Turn control switch to "ON". If arcing occurs or the indicating light flickers, the components may still be damp. Turn the unit OFF and allow the cells to dry completely.

Inspections

The motors and blowers on TRION T1300 and T2600 air cleaners have sealed ball bearings and never need lubricating.

Belt tension should be checked periodically. When a moderate force is applied to the belt midway between the pulleys, the belt should deflect approximately ½" (13 mm).

CAUTION

Having too much tension on the belts will shorten the belt life and place undue stress on the motor and blower bearings.

Replacement Parts Ordering

The following pages contain exploded views and Bills of Material for the TRION T-Series Air Cleaners. Use these pages to determine the part numbers of the items needed. To order parts contact your local TRION representative and provide the following information:

- Unit Model Number – located on the data label near the junction box
- Part Number and Description – from exploded views

Warranty

All TRION Electronic Air Cleaners are warranted for 3 Year Limited Warranty on units and 1 Year Limited Warranty on replacement parts. Labor is NOT included. Do not return defective parts without permission from the factory and a material return acceptance number.

Troubleshooting Guide

T1001/T2002 Problems and Possible Causes

1. Indicating Light Out
 - a. Unit not plugged in
 - b. Control switch "Off"
 - c. Cell access panel not fully closed
 - d. Broken cell insulator
 - e. Extremely dirty cells
 - f. Service panel not secured in place
2. Excessive arcing noise after washing
 - a. Collector elements still wet – Allow more drying time
 - b. See "Continuous arcing noise" below
3. Continuous arcing noise and flickering indicating light
 - a. Extremely dirty collector plates
 - b. Bent collector plates
 - c. Large piece of material lodged between cell plates
4. Contaminant Bypass
 - a. Velocity of airflow is too high through unit
 - b. Collector plates not grounded
 - c. Collector cell not making solid connection to access door and high voltage contact

IF PROBLEM CANNOT BE DETERMINED OR CORRECTED - CONTACT YOUR LOCAL TRION REPRESENTATIVE OR CALL TRION CUSTOMER SERVICE AT 1-800-884-0002 FOR ASSISTANCE.

T1300/T2600 Problems and Possible Causes

The troubleshooting chart, shown on the next page, will enable the user to pinpoint the cause of most problems. Refer to the Ordering Information for replacement parts. Before performing any troubleshooting, ensure the correct input line voltage is present.

WARNING

Factory designed access to all electrically charged high voltage components contain electrical interlocks for the safety of operating personnel. Always unplug the unit while performing service within the cabinet.

Troubleshooting Diagram

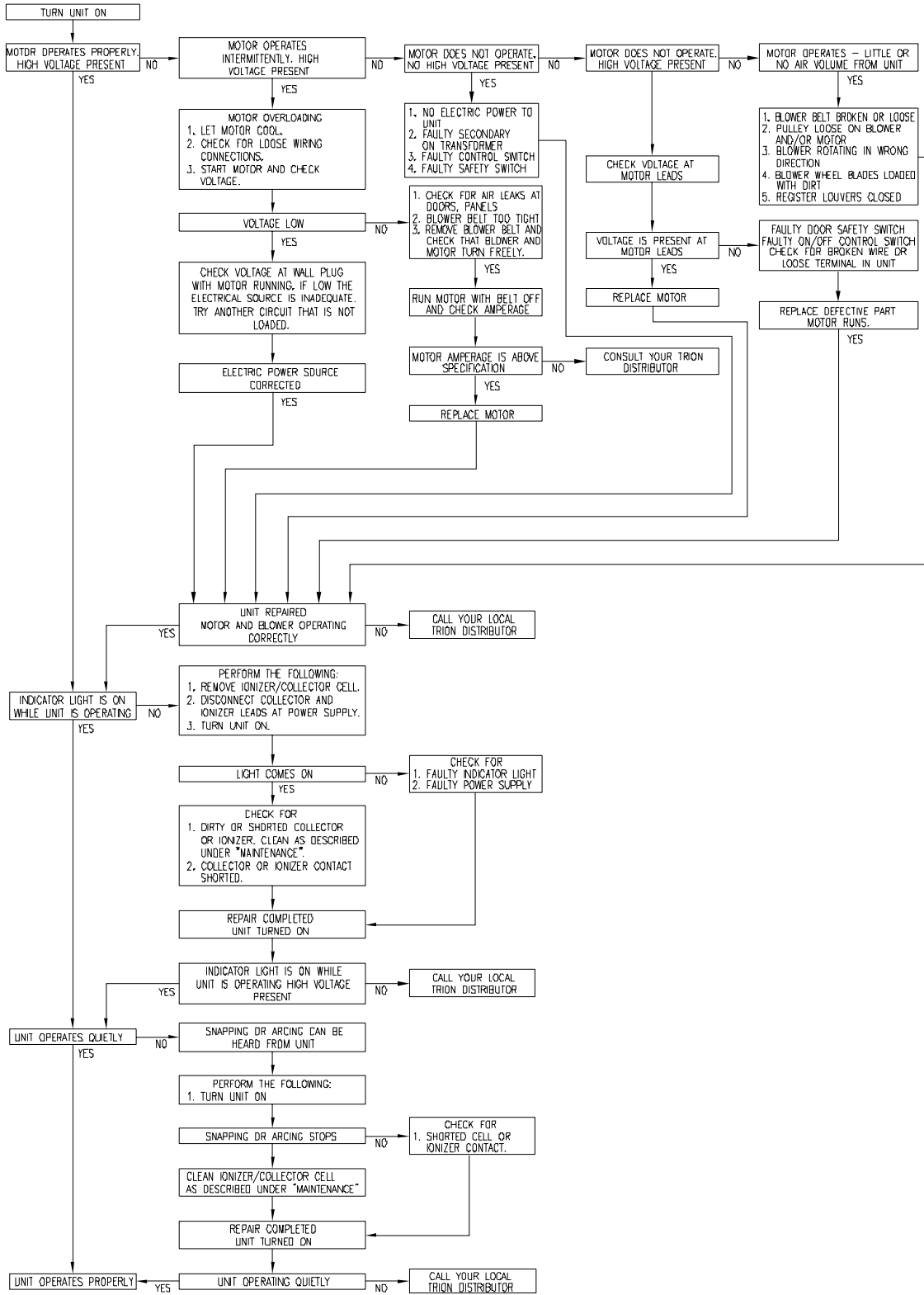

T1300 Unit Assembly

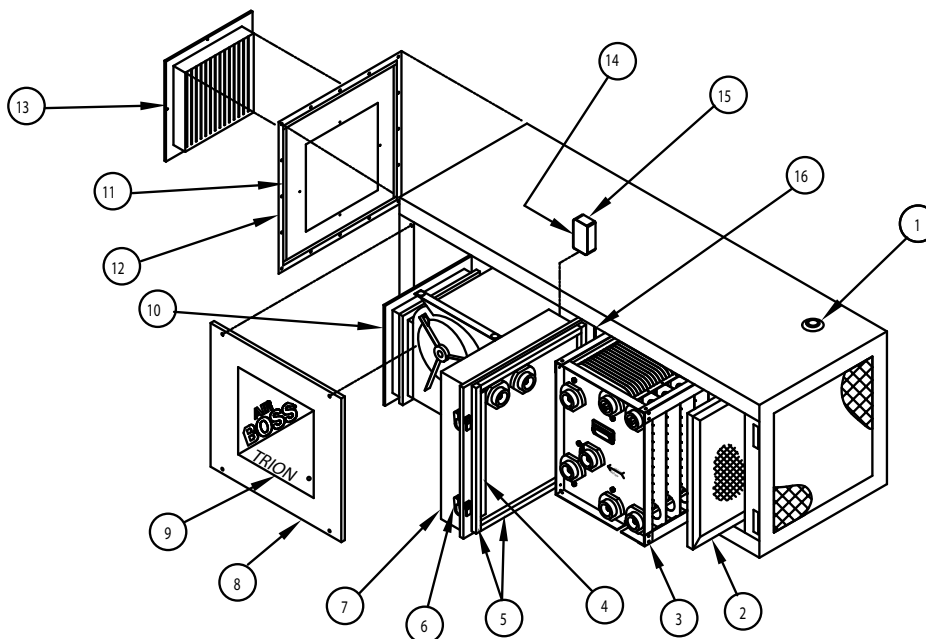

Item	TRION Part No.	Description	Qty.
1	247962-002	Cap Plug	2
2	224451-006	Aluminum Mesh Filter	1
3	450568-001 (English) 450568G-001 (Metric)	Ionizer Collector Cell	1
4	224779-028	Gasket, Adhesive Back (3/4" x 11/16")	61"
5	224779-015	Gasket, Adhesive Back (1" x 1/4")	122"
6	334562-005	Draw Latch	2
7	348667-001 (English) 348667G-001 (Metric)	Control Enclosure Assembly	1
8	448647-001	Blower Access Door Assembly	1
9	252029-002	Label	1
10	337861-001 (English) 060070-001 (Metric)	Blower Assembly	1
11	224779-026	Gasket, Adhesive Back (1/2" x 1/16")	80"
12	348642-001	Outlet Panel	1
13	69000-0002-05	Grille Assembly	1
14	149882-001	Outlet Box Cover	1
15	249884-001 (English) 249884G-001 (Metric)	Outlet Box	1
16	146442-001 (English) 146442G-001 (Metric)	Hinge	2

T2600 Unit Assembly

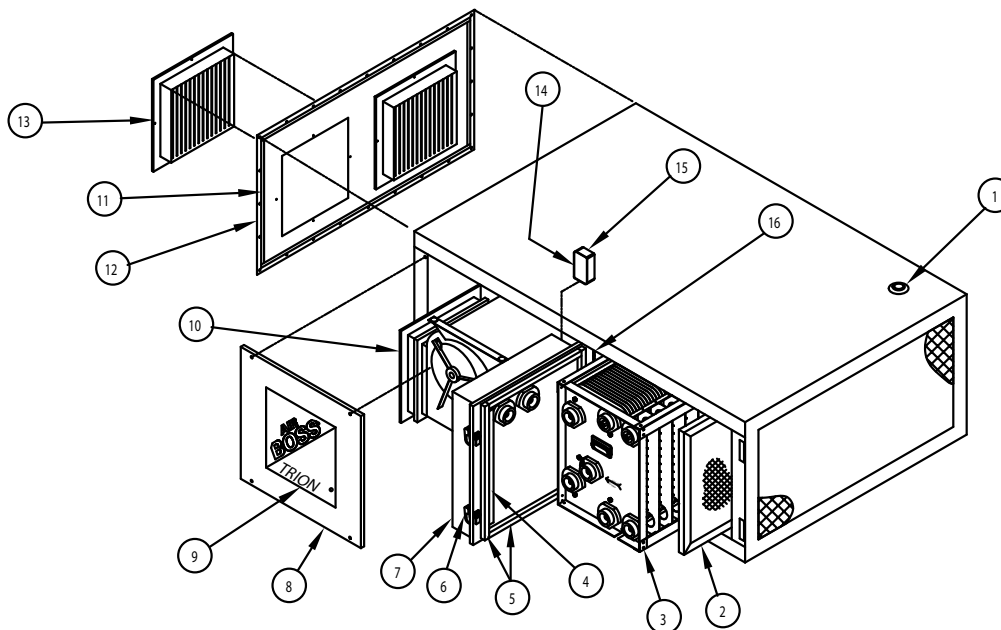

Item	TRION Part No.	Description	Qty.
1	247962-002	Cap Plug	2
2	224451-006	Aluminum Mesh Prefilter	2
3	450568-001 (English) 450568G-001 (Metric)	Ionizer Collector Cell	2
4	224779-028	Gasket, Adhesive Back (3/4" x 11/16")	61"
5	224779-015	Gasket, Adhesive Back (1" x 1/4")	122"
6	334562-005	Draw Latch	2
7	348667-001 (English) 348667G-001 (Metric)	Control Enclosure Assembly	1
8	448647-001	Blower Access Door Assembly	1
9	252029-002	Label	1
10	437945-001 (English) 060070-002	Dual Blower Assembly	1
11	224779-026	Gasket, Adhesive Back (1/2" x 1/16")	115"
12	337944-002	Outlet Panel	1
13	69000-0002-05	Grille Assembly	2
14	149882-001	Outlet Box Cover	1
15	249884-001 (English) 249884G-001 (Metric)	Outlet Box	1
16	146442-001 (English) 146442G-001 (Metric)	Hinge	2

T1001 Module Assembly

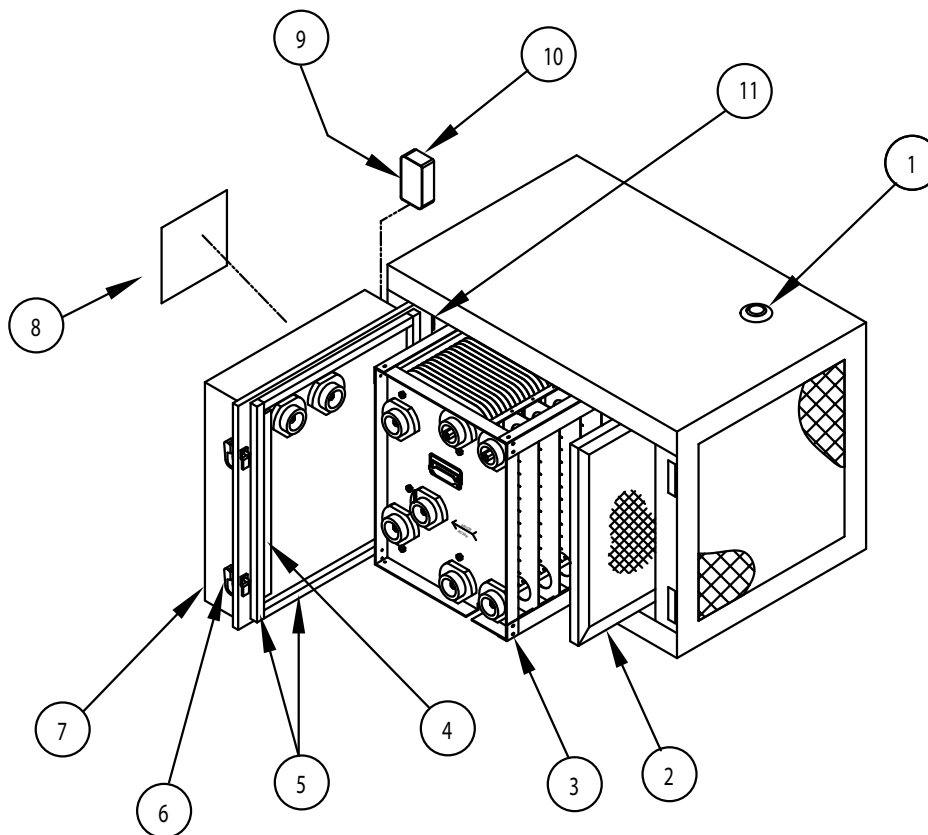

Item	TRION Part No.	Description	Qty.
1	247962-002	Cap Plug	2
2	224451-006	Aluminum Mesh Prefilter	1
3	450568-001 (English) 450568G-001 (Metric)	Ionizer Collector Cell	1
4	224779-028	Gasket, Adhesive Back (3/4" x 11/16")	19"
5	224779-015	Gasket, Adhesive Back (1" x 1/4")	86"
6	334562-005	Draw Latch	2
7	348667-001	Control Enclosure Assembly	1
8	252029-001	Label	1
9	149882-001	Outlet Box Cover	1
10	249884-001 (English) 249884G-001 (Metric)	Outlet Box	1
11	146442-001 (English) 146442G-001 (Metric)	Hinge	2

T2002 Module Assembly

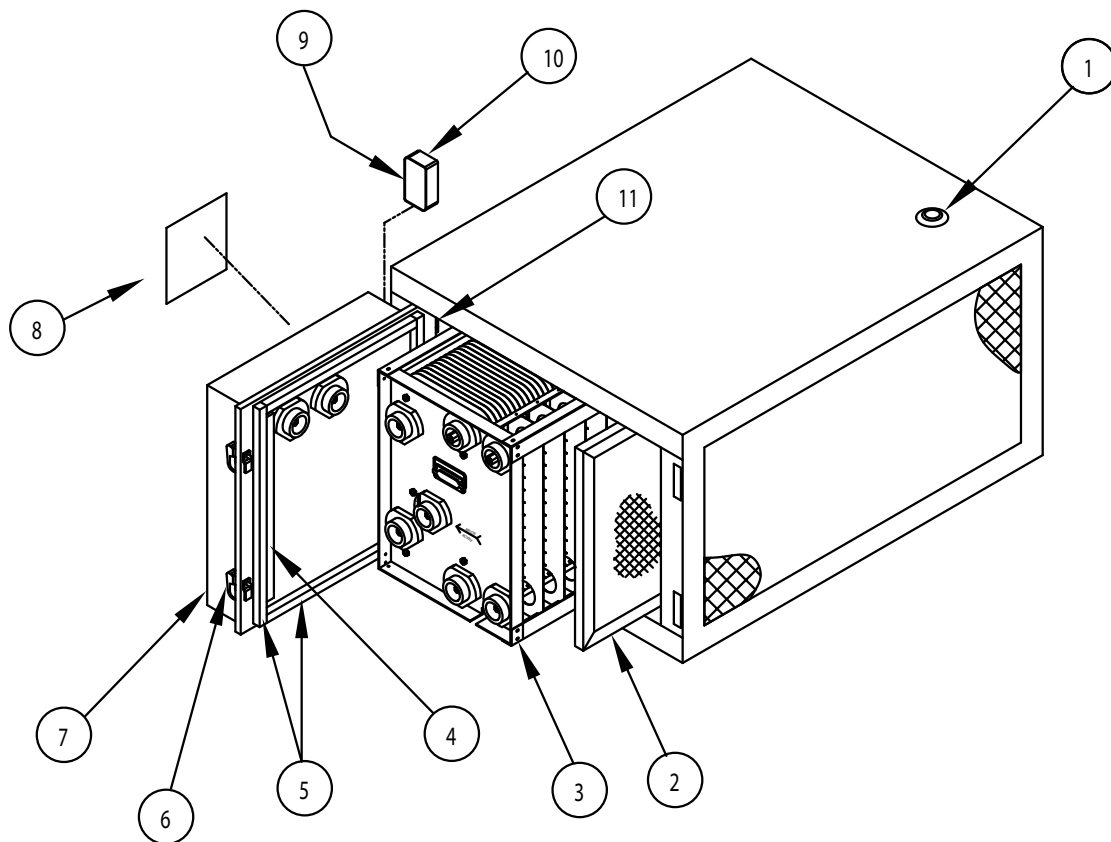

Item	TRION Part No.	Description	Qty.
1	247962-002	Cap Plug	2
2	224451-006	Aluminum Mesh Prefilter	2
3	450568-001 (English) 450568G-001 (Metric)	Ionizer Collector Cell	2
4	224779-028	Gasket, Adhesive Back (3/4" x 11/16")	19"
5	224779-015	Gasket, Adhesive Back (1" x 1/4")	86"
6	334562-005	Draw Latch	2
7	348667-001	Control Enclosure Assembly	1
8	252029-001	Label	1
9	149882-001	Outlet Box Cover	1
10	249884-001 (English) 249884G-001 (Metric)	Outlet Box	1
11	146442-001 (English) 146442G-001 (Metric)	Hinge	2

Enclosure Assembly

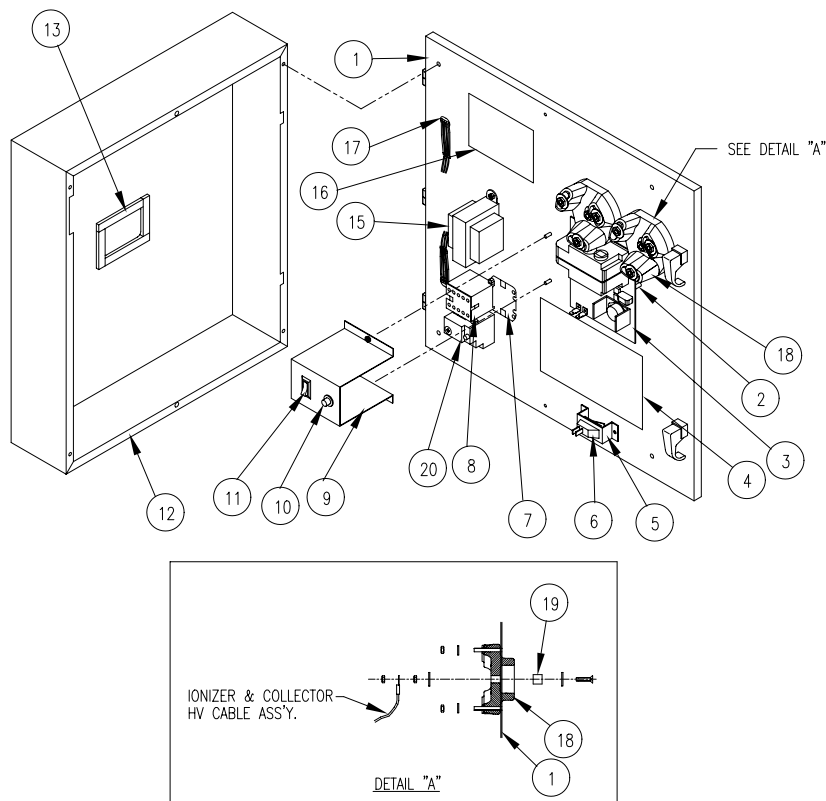

ITEM	TRION PART NO.	DESCRIPTION	QTY.
1	457056-001 (ENGLISH)	Cell Door Assembly	1
	457056G-001 (METRIC)	Cell Door Assembly	1
2	119036 (ENGLISH)	Spacer, Hex	3
	119036G (METRIC)	Spacer, Hex	3
3	347891-013	High Frequency Power Supply (T1300 & 1001)	1
	347891-026	High Frequency Power Supply (T2600 & 2002)	1
4	251257-001	Wiring Label 575V/60HZ/3 PH (T1300 & T2600)	1
	249043-001	Wiring Label 240V/50-60HZ/1 PH (T1300 & T2600)	
	249044-001	Wiring Label 120V/60HZ/1 PH (1001 & 2002)	
	249045-001	Wiring Label 208,230,460V/60HZ/3 PH (1001 & 2002)	
	249046-001	Wiring Label 240V/50HZ/1 PH (1001 & 2002)	
	248751-001	Wiring Label 208,230,460V/60HZ/3 PH (T1300 & T2600)	
	248752-001	Wiring Label 120V/60HZ/1 PH (T1300 & T2600)	
	5	248604-001	Interlock Switch Bracket
6	244833-001	Interlock Switch	1

ITEM	TRION PART NO.	DESCRIPTION	QTY.
7	249005-001	Contactor, 2 Pole (Single Phase Units Only)	1
8	247292-001	Contactor, (3 Phase Units Only)	1
9	348605-001	Light Switch Bracket	1
10	241101-009	Indicator Light	1
11	138586-001	Switch - Off/On	1
12	224779-012	Gasket, Adhesive Back (1/4" x 1/8")	75"
	224779-014	Gasket, Adhesive Back (1/2" x 3/16")	12"
	248655-005	Transformer (120/208/240V-24)	1
	248655-004	Transformer (480V-24)	
	248655-007	Transformer (575V-24)	
16	121390-001	Warning Label, High Voltage	1
17	143817-001	Strain Relief Bushing	2
18	353228-002	Standoff Insulator, Ceramic	2
19	222781-033	Spacer	2
20	250418-007	Overload Relay (575V unit only)	1

Blower/Motor Assembly

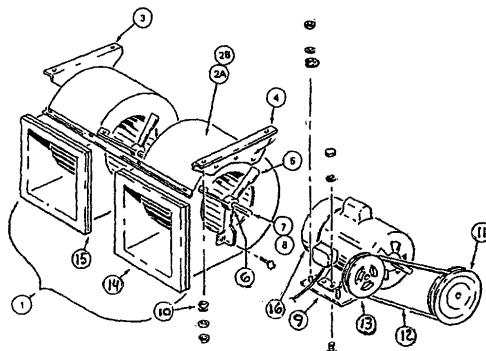

Item	TRION Part No.	Description	1300	2600
1	437945-001 (English) 060070-002 (Metric)	DBL, Blower Assy - Less Motor		X
1A	337861-001 (English) 060070-001 (Metric)	Blower Assy - Less Motor	X	
2A	337923-101	Blower Housing	X	X
2B	337923-102	Blower Wheel	X	X
3	337923-104	Blower Foot RH	X	X
4	337923-105	Blower Foot LH	X	X
5	337923-103	Bearing Frame	X	X
6	62000-0003-0100	Bearing, Ball	X	X
7	237787-001	Shaft, Blower		X
7A	237959-001	Shaft, Blower	X	
8	1250-1200-07	Key, Shaft	X	X
9	343636-001	Motor Mounting Plate	X	X
10	425541-114	Grommet	X	X
11	125699-003	Sheave or Pulley (motor)	X	X
11A	125699-029 (English) 060066-007 (Metric)	Sheave or Pulley (motor) 2 HP		X
12	220926-032 (English) 060068-001 (Metric)	Belt 4L 450 Belt SPZ 1120	X	X
12A	220926-035 (English) 060068-003 (Metric)	Belt 4L 450, 2 HP Belt SPZ 1120, 2 HP		X
13	124053-072 (English) 060066-002 (Metric)	Pulley Blower (6.5 PD) Pulley Blower	X	X
13A	124053-058 (English) 060066-008 (Metric)	Pulley Blower (6.2 PD) Pulley Blower		X
14	224779-028	Gasket, (3/4" x 11/16" x 4") per Blower	X	X
15	337849-001	Blower Gasket Flange	X	X
16	141434-001	Motor 120-240V/60Hz/1 PH/3/4 HP	X	X
16A	140197-001	Motor 240V/50Hz/1 PH/3/4 HP	X	X
16B	137128-001	Motor 208-240-480V/60Hz/3 PH/1 HP	X	X
16C	148958-001	Motor 208-240-480V/60Hz/3 PH/2 HP		X
16D	142756-001	Motor 575V/60Hz/3 PH/1 HP	X	X

Ionizer/Collector Cell

Part Number 450568-001 (English)/450568G-001 (Metric)

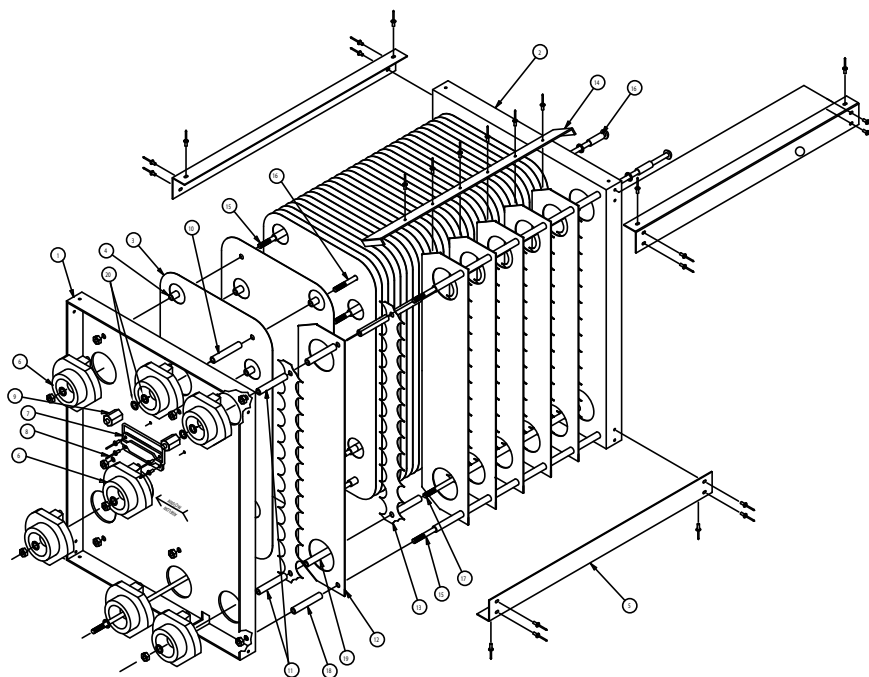

ITEM	TRION PART NO.	DESCRIPTION
1	450551-001	End Plate (L.H.)
2	450551-002	End Plate (R.H.)
3	226555-001	High Voltage & Ground Plate
4	220107-070	Spacer
5	247924-002	Cell Brace
6	352212-002	Insulator
7	124537-001	Handle
8	220976-044	Rivet
9	147704-002 (ENGLISH) 147704G-002 (METRIC)	Contact Contact
10	220107-111	Spacer
11	220107-112	Spacer, Spike To Insulator

ITEM	TRION PART NO.	DESCRIPTION
12	247782-001	Ionizer Ground Plate
13	347892-001	Spiked Ionizer Blade
14	250567-001	Brace
15	233137-031 (ENGLISH) 233137G-031 (METRIC)	Tie Rod Tie Rod
16	233137-030 (ENGLISH) 233137G-030 (METRIC)	Tie Rod Tie Rod
17	233137-015 (ENGLISH) 233137G-015 (METRIC)	Tie Rod Tie Rod
18	220107-109	Spacer, Ionizer Ground
19	220107-110	Spacer, Spike
20	121993-006	Fiber Washer

Blower Curves

T-1300

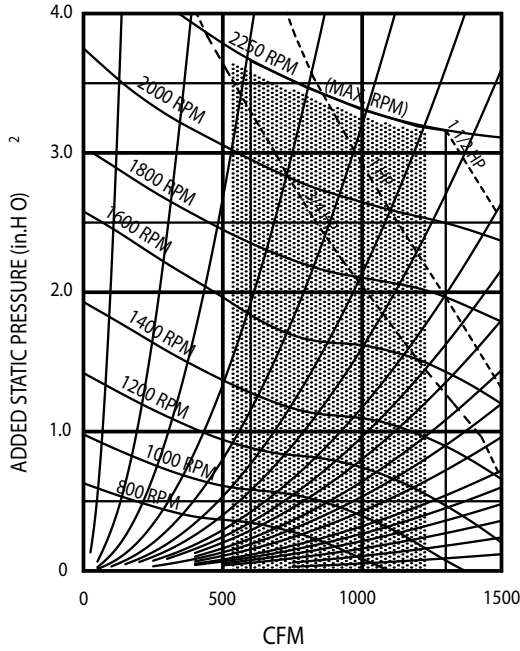

T-2600

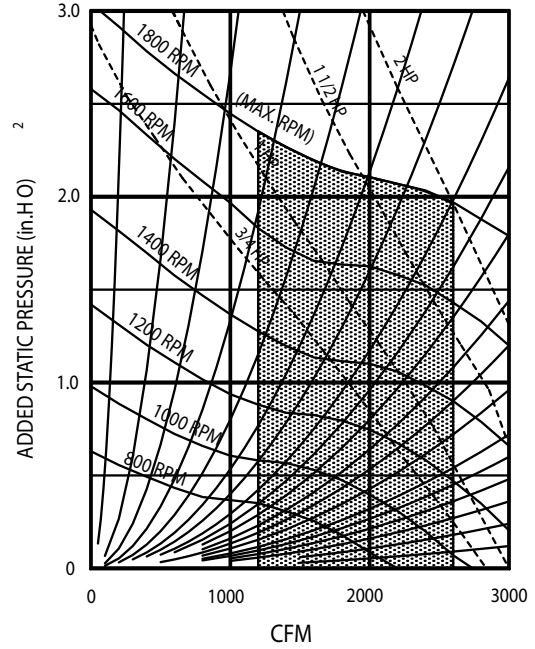

T-1300

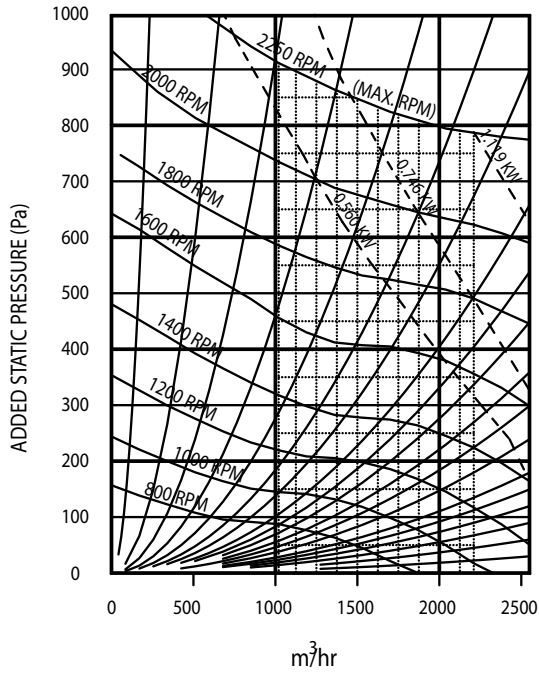

T-2600

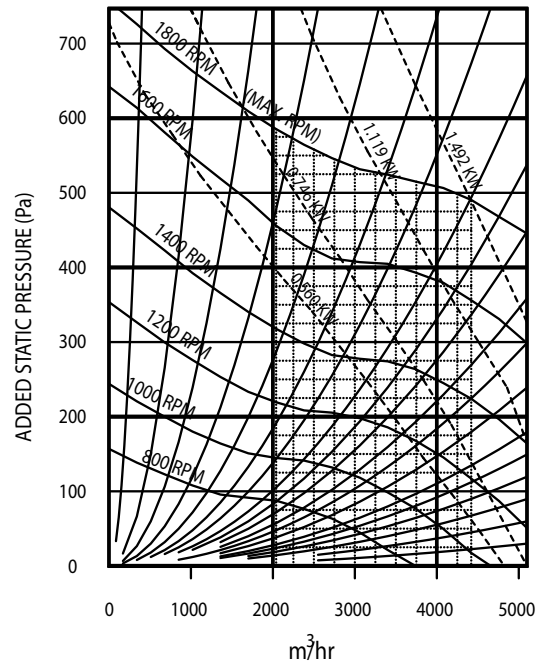

Wiring Diagrams

T1300 or T2600 (1 HP or 2 HP)

208V/60Hz/3 PH - 230V/60Hz/3 PH - 460V/60Hz/3 PH

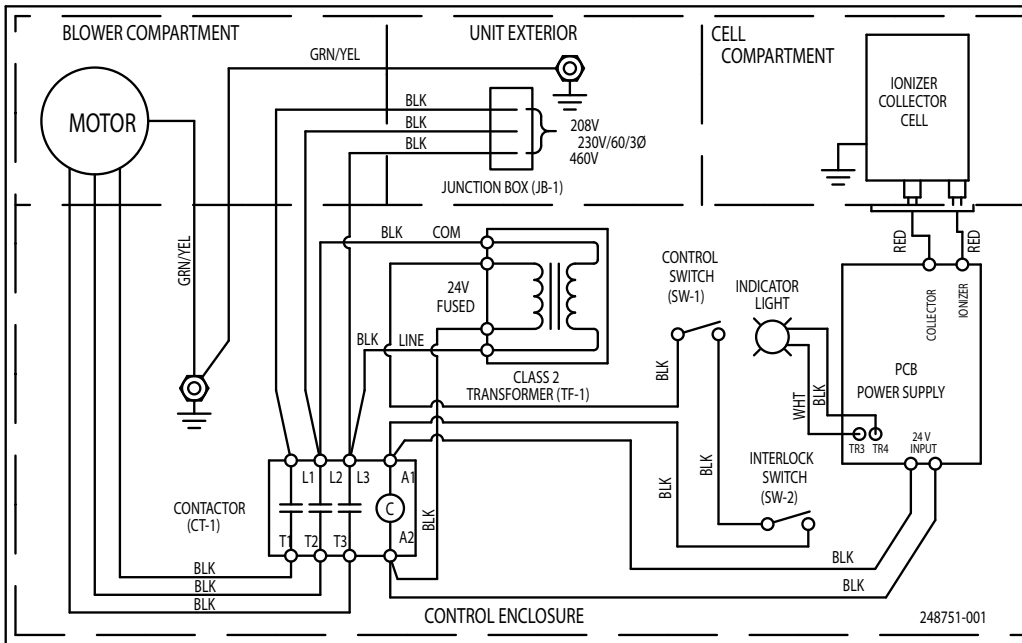

T1300 or T2600 (3/4 HP)

120V/60Hz/1 PH

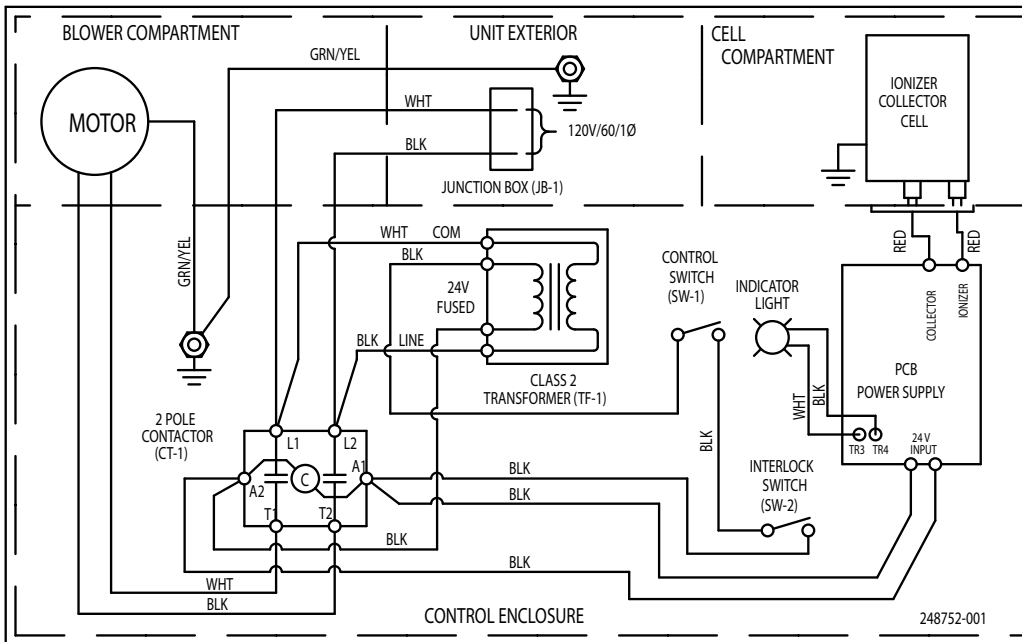

T1300 or T2600 (1 HP)
575V/60Hz/3 PH

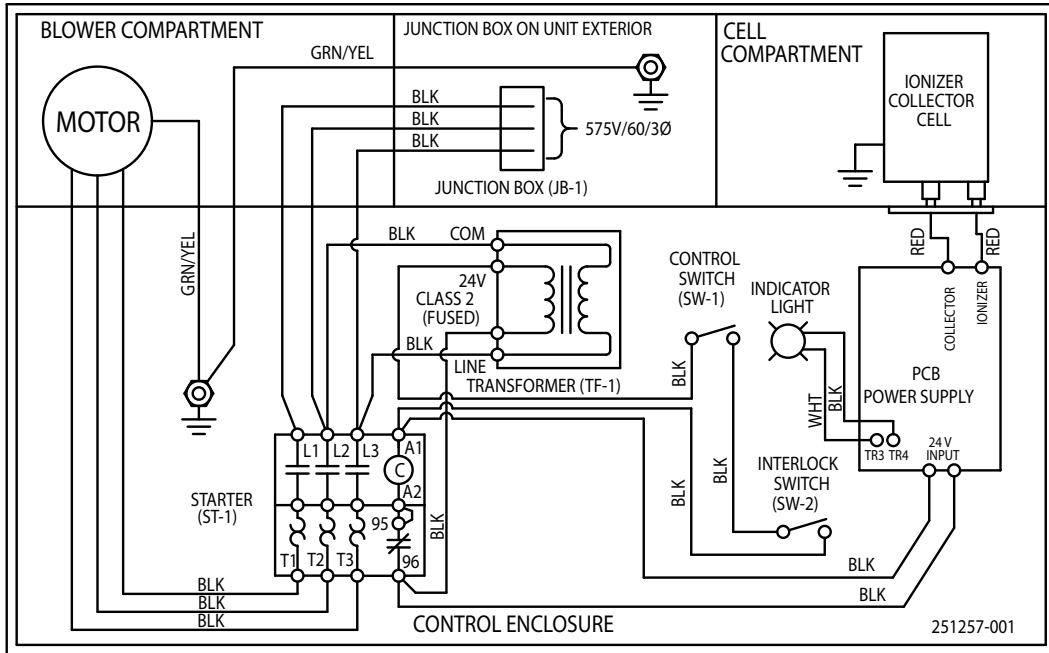

T1300 or T2600 (3/4 HP)
240V/60Hz/1 PH - 240V/50Hz/1 PH

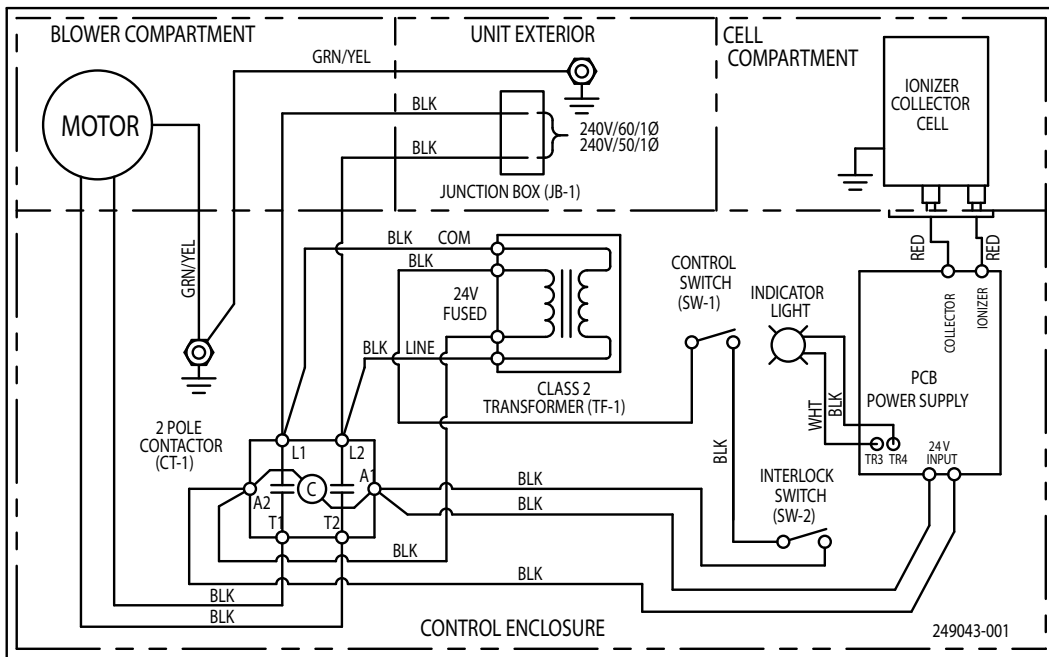

T1001 & T2002 Module 120V/60Hz/1 PH

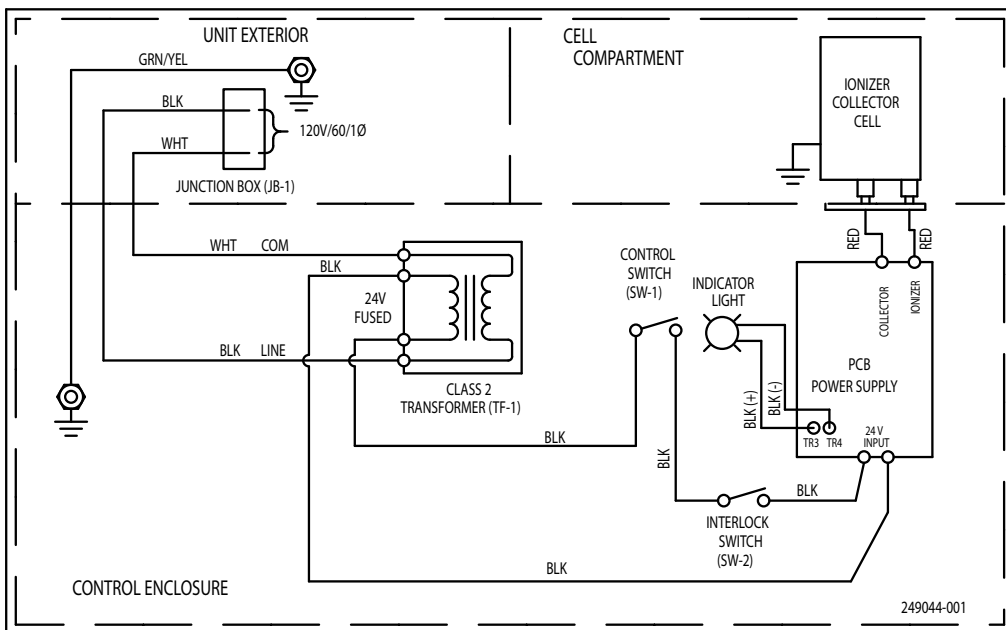

T1001 & T2002 Module 208V/60Hz/3 PH - 230V/60Hz/3 PH - 460V/60Hz/3 PH

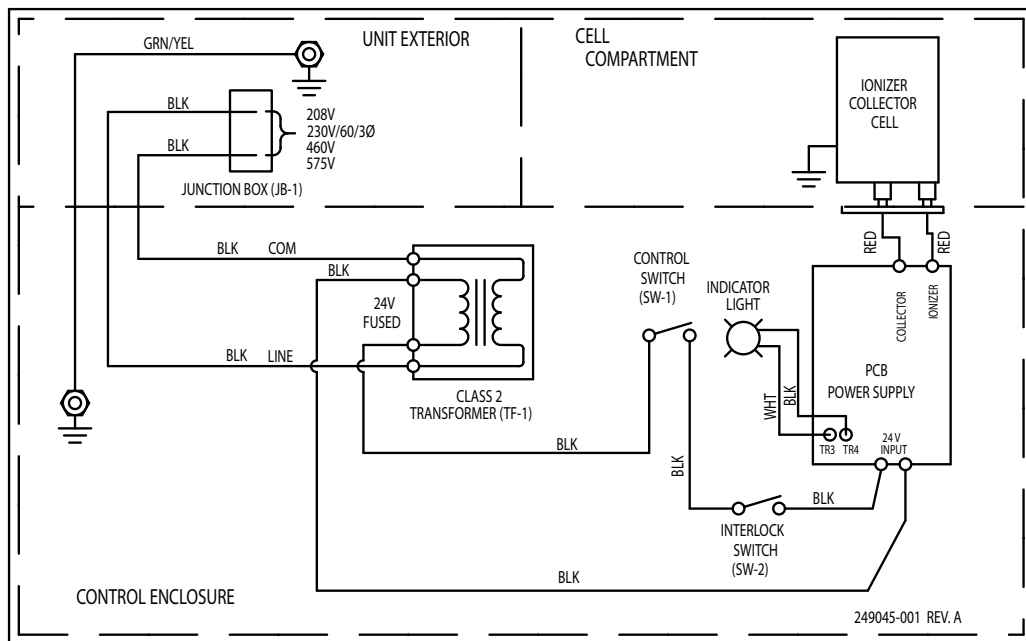

T1001 & T2002 Module
 240V/60Hz/1 PH - 240V/50Hz/1 PH

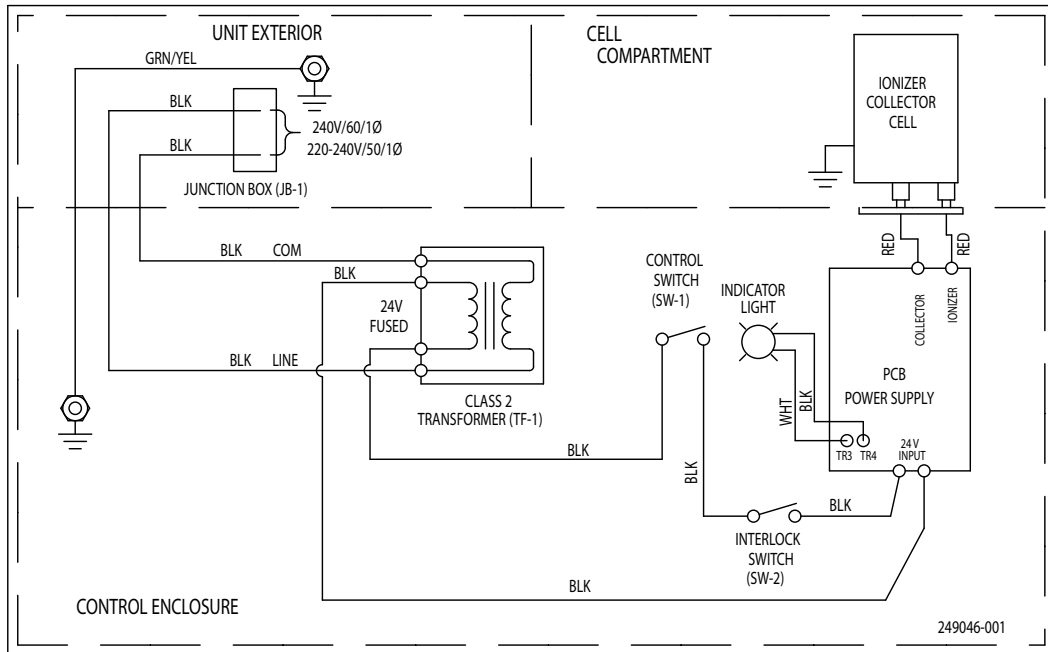



TRION®

101 McNeill Rd. | Sanford, NC 27330

P: 800.884.0002 | F: 800.458.2379 | www.trioniaq.com | customerservice@trioniaq.com
