

CA 3000C

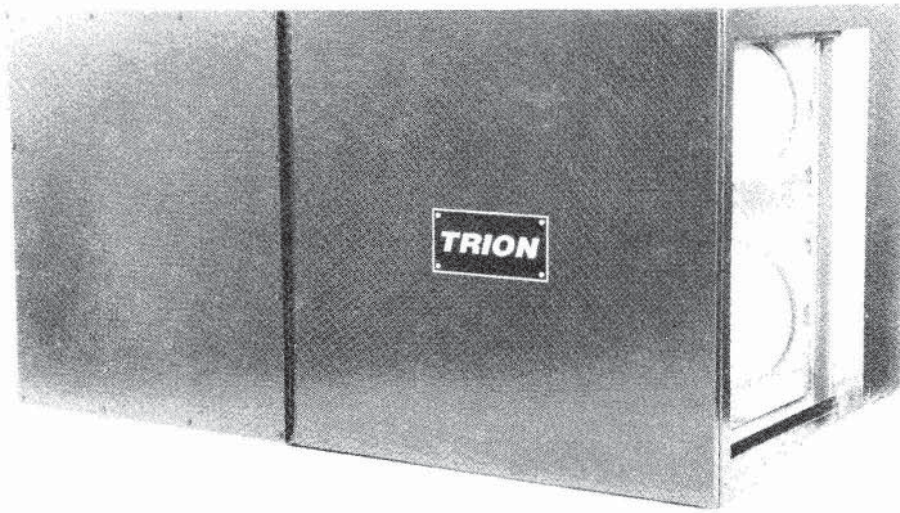

Manual for:

Installation • Operation • Maintenance

TRION[®]

TABLE OF CONTENTS

PRECAUTIONARY STATEMENTS ON APPLICATION AND OPERATION	2
INTRODUCTION	2
EXPLANATION OF OPERATION	2
PRE-INSTALLATION CONSIDERATIONS	4
INSPECTION	4
INSTALLATION	4
MOUNTING	5
PIPING	5
MAGNEHELIC GAGE OPTION	5
ELECTRICAL	6
OPERATION	6
CLEANING	6
ADJUSTMENTS	6
SERVICE	7
CARTRIDGE REMOVAL/ REPLACEMENT	7
PARTIAL PARTS LIST (MAJOR & OPTIONAL COMPONENTS)	12, 13

LIST OF DRAWINGS AND ILLUSTRATIONS

FIG. 1	AIR FLOW, NORMAL OPERATION	2
FIG. 2	AIR FLOW, PURGING/CLEANING CYCLE	2
FIG. 3	TYPICAL INSTALLATION ARRANGEMENT	3
FIG. 4	TYPICAL INSTALLATION SCHEMATIC	3
FIG. 5	CABINET AIR FLOW ARRANGEMENTS	4
FIG. 6	TYPICAL SUSPENSION HANGER SECUREMENT	5
FIG. 7	MAGNEHELIC GAGE HOOKUP	5
FIG. 8	EXPLODED PARTS DRAWING	11
FIG. 9	WIRING DIAGRAM, STANDARD MANUAL CLEANING	14
FIG. 10	WIRING DIAGRAM, OFF-LINE MANUAL CLEANING	15
FIG. 10A	ALTERNATE WIRING DIAGRAM, OFF-LINE MANUAL CLEANING	16
FIG. 11	WIRING DIAGRAM, PRESSURE SWITCH OPTION, AUTOMATIC CLEANING	17
FIG. 12	WIRING DIAGRAM, 7-DAY TIMER OFF-LINE, SEMI-AUTOMATIC CLEANING	18
FIG. 13	BLOWER CURVES	8, 9, 10

CAUTION:

APPLICATION & OPERATION OF TRION CARTRIDGE AIR CLEANERS:

Due to potential fire hazards, do not mix combustible materials with those that would be a potential source of ignition.

Examples of Combustible Materials:

Wood dust
Paper dust
Lint from fabrics or buffing wheels
Grinding dust from painted surfaces
Aluminum or magnesium dusts

Examples of Potential Ignition Sources:

Grinding dust from ferrous metals
Hot ash from any source

2. This equipment should not be used for the collection of any materials where there is a risk of explosion. Pressure relief vents or explosion vents should not be applied to the equipment or any adjoining system.
3. Equipment location, installation and operation should comply with all National and Local Fire Codes. When in doubt consult the proper authorities.
4. Workers and machine operators should be instructed to keep any burning objects, such as cigarettes, safely away from air inlets leading to the equipment.
5. All those involved with the use of this equipment should comply with the statements pertaining to worker safety as noted in this manual.

INTRODUCTION

The TRION Cartridge Air Cleaner is designed to filter dry solid particulates such as weld fume and dusts from plant ambient air, then circulate the cleaned air back into the work space. The unit may be ceiling suspended or base supported and utilized in free hanging or source capture installations.

The unit may be arranged for the air to flow horizontally or enter from the top with horizontal discharge from right to left or left to right (See Fig.5)

Once mounted, the connection of electrical power and compressed air complete the installation.

The configuration of the filtering media provides a large surface area (904 ft² total - standard) for increased dirt holding capacity which prolongs the time between cleaning.

The cartridges are positioned for easy service when replacement is required.

EXPLANATION OF OPERATION

During normal operation, contaminated air is pulled through the filtering cartridges and the particulate is collected on the outside of the filtering media. The filtered air then passes through the clean air plenum and is exhausted through directional louvers.

When the cartridges require cleaning, a sequential timer is activated. This is accomplished with a manually operated switch or automatically with a 7 day time control or a pressure switch/gage sensor. (See Optional Components, page 8). The timer sequentially opens and closes air valves, directing pulses of compressed air through the cartridges, from the inside-outward, which dislodges the collected contaminant from the filtering media. The alternating pulsing between the cartridges continues until the timer is turned off, either manually or automatically.

The dislodged contaminant falls to the bottom of the unit or into the optional hopper.

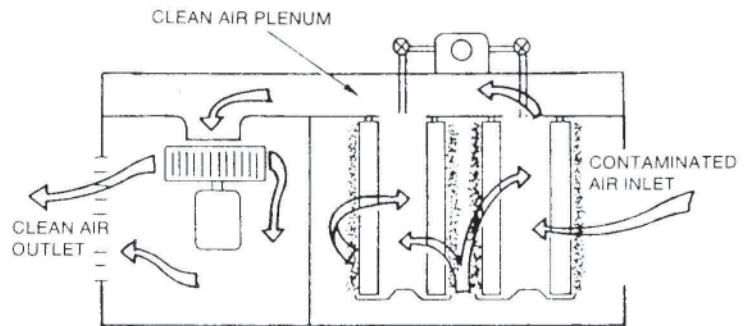

AIR FLOW,
NORMAL OPERATION
(TOP VIEW)

FIGURE 1

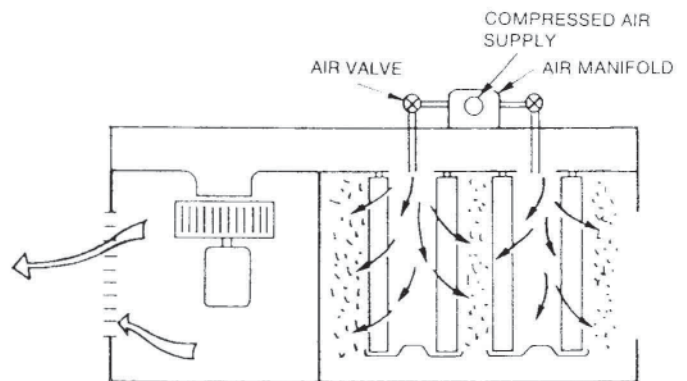

AIR FLOW,
PURGING/CLEANING CYCLE
(TOP VIEW)

FIGURE 2

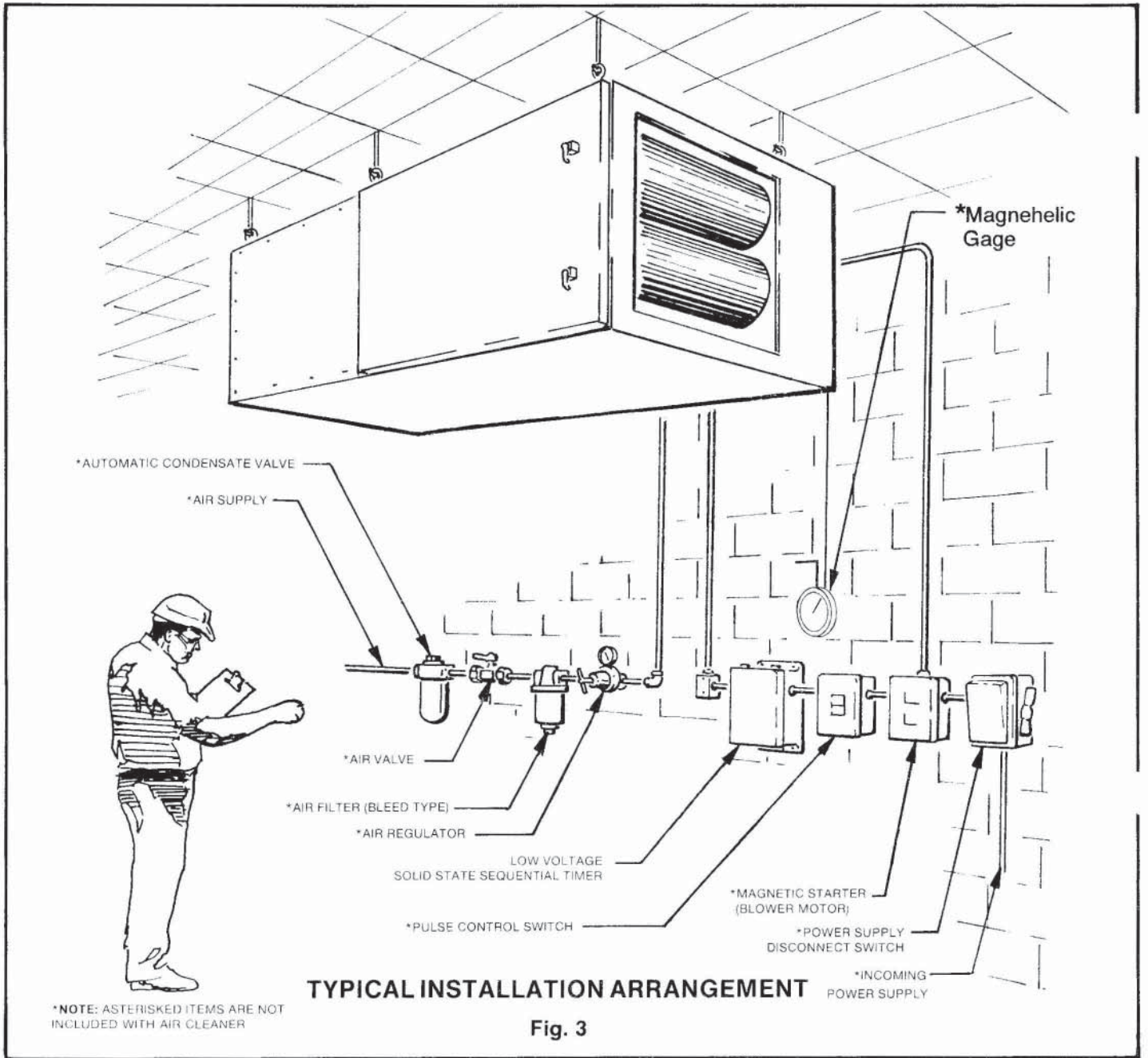
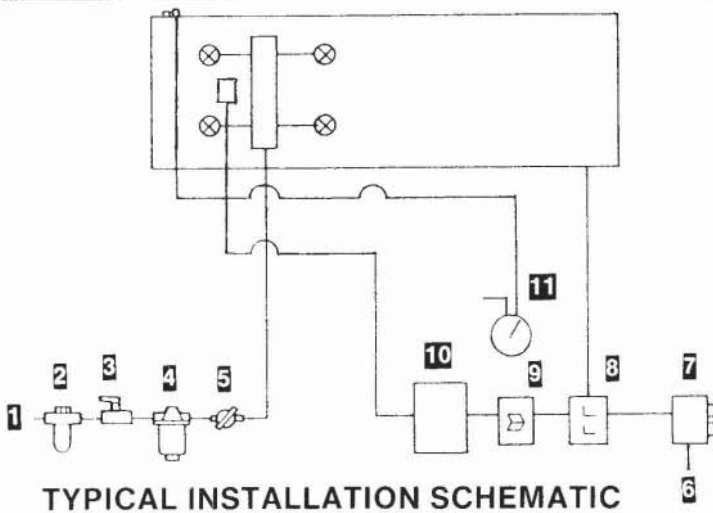

Fig. 3



- 1 *Compressed Air Supply
 - 2 *Automatic Condensate Valve
 - 3 *Air Shut-Off Valve
 - 4 *Air Filter (Bleed Type)
 - 5 *Air Regulator
 - 6 *Incoming Power Supply
 - 7 *Power Supply Disconnect Switch
 - 8 *Magnetic Starter (Blower Motor)
 - 9 *Cleaning (Air Pulse) Control Switch
 - 10 Sequential Timer
 - 11 *Magnehelic Gage
- *Not Supplied with Air Cleaner

FIGURE 4

PRE-INSTALLATION CONSIDERATIONS

The location of the unit(s) should be planned to maximize efficient operation. Consult your TRION representative for clarification of questionable situations.

For free hanging installations, the unit(s) should be positioned as close to the source of contaminant as practical and at the height where stratification of the particulate takes place. If more than one unit is to be installed in a given area, it is important to create a clockwise (or counter-clockwise) air flow pattern around the area.

When ducting is utilized, the static pressure created by the duct work must be considered in conjunction with the pressure that will be created by the buildup of contaminant on the cartridge filters. Refer to the Blower Curves on pages 8, 9 and 10.

The unit(s) should be positioned to provide adequate service space to the compressed air valves, access panels and doors.

Ceiling hangers, wall mounting brackets and associated hardware must be capable of safely supporting the weight of the unit (780 lbs.) plus the weight of any added options and any auxiliary equipment. Refer to the Optional Components list and unit specification sheet for weights and dimensions.

INSPECTION

Upon receipt, the unit should be inspected for any damage incurred in shipping. Damage should be noted and a claim immediately filed with the carrier.

INSTALLATION

Each unit is shipped from the factory fully assembled with the air filtering cartridges installed. To prevent damage to the filter brackets during shipment, a sheet metal panel is installed on the access end of the cartridges. It is recommended that the cartridges and support panel be removed and safely stored during the installation of the cabinet. Once the unit is installed, the support panel is no longer required and can be discarded.

As shipped, the unit is setup for the air to flow horizontally through the cabinet from right to left. See Figure 5A. To change the direction of air flow horizontally, simply turn the unit 180° end for end and turn the logo label over. The label is secured with threaded fasteners. See Fig. 5.

If necessary, the unit can be arranged to have the contaminated air enter from the top of the unit by removing the top panel of the cartridge compartment and installing it on the existing opening in the end of the unit. (All panels are interchangeable.) See Figures 5C and 5D. Depending on the planned treatment of the incoming contaminated air, additional sheet metal work may be required.

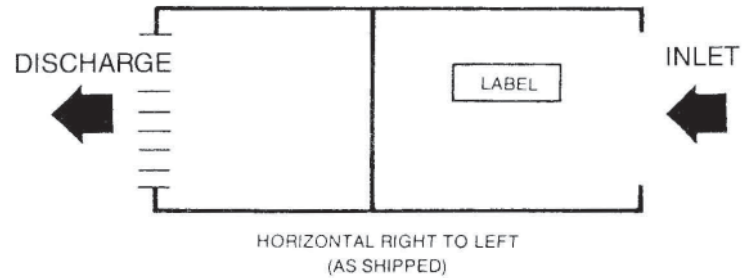

FIGURE 5A

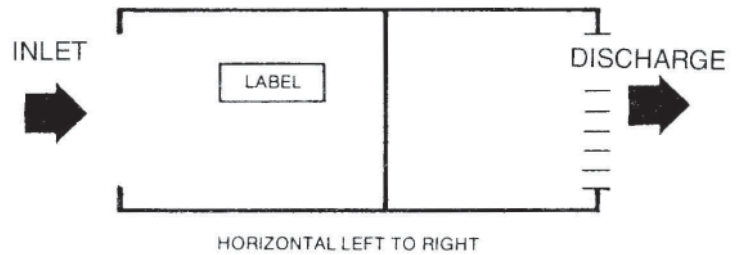

FIGURE 5B

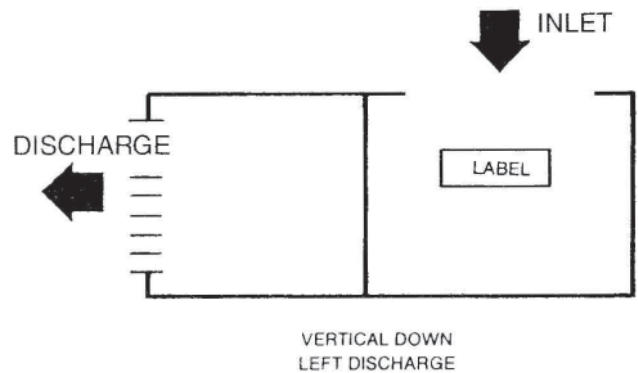

FIGURE 5C

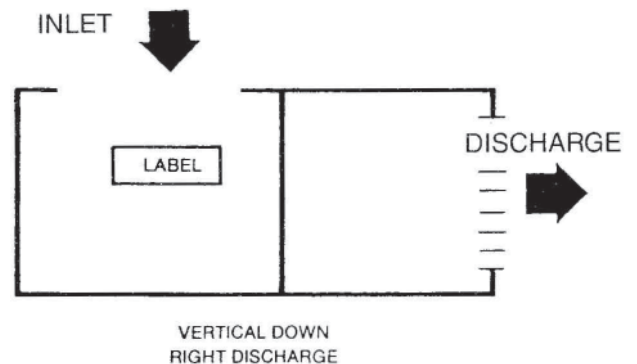

FIGURE 5D

FIGURE 5

CABINET AIR FLOW ARRANGEMENTS
(ALL TOP VIEWS)

When the air flow arrangement has been established, install any of the options or accessory equipment, such as a contaminant hopper, which replaces the bottom panel of the cartridge compartment, or an inlet plenum that bolts to the front of the inlet opening. All optional equipment is packaged and shipped separately.

MOUNTING

Next, secure the unit in the planned location. The cabinet will lend itself to whatever means of support is best suited for the particular location. Whichever arrangement is used, it must safely support the weight of the unit (780 lbs.), any of the options or auxiliary equipment used, plus the heaviest load of contaminant to be collected. Refer to unit specification sheet and consult authorities concerning building code restrictions.

Typically, most units will be suspended from the ceiling. For suspension, the top of the cabinet contains six places to receive 1/2"-13 threaded rod or mounting hardware. Remove and discard the factory installed bolts from these mounting points. See Figure 6 for a typical arrangement to secure threaded rod to the cabinet.

After the unit has been suspended, it should be adjusted to a level position and all fasteners tightened.

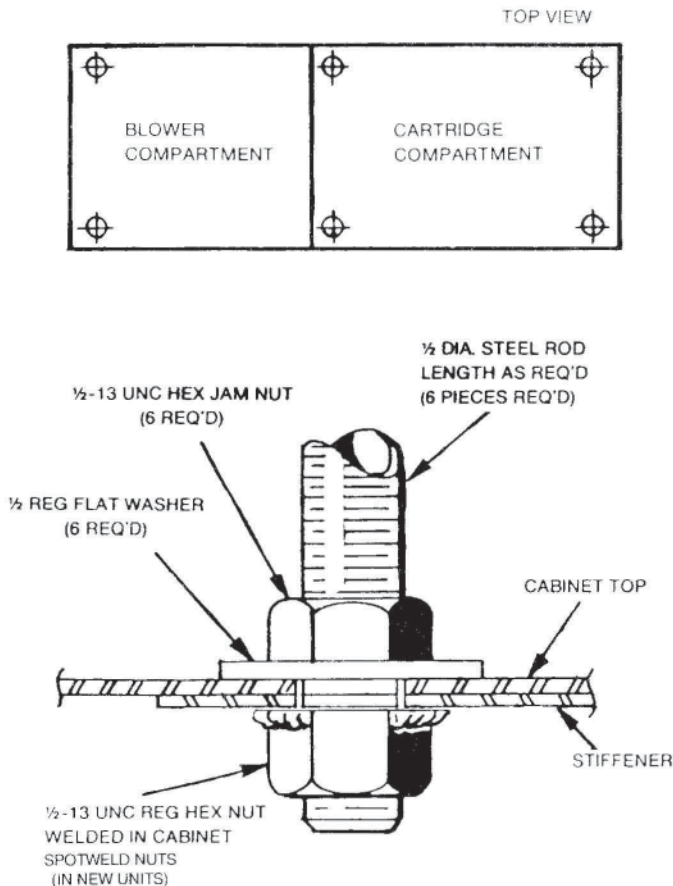

FIGURE 6

TYPICAL SUSPENSION HANGER SECUREMENT

PIPING

The compressed air supply for the pulse cleaning system should be free from oil and moisture. This is important because contamination in the air supply will reduce cleaning efficiency and result in a loss in performance.

NOTE: Purge the air line to remove all debris before completing the connection to the air manifold tank located on the top of the air cleaner.

As shown in Figures 3 and 4, install an automatic condensate valve, shut-off valve, bleed type filter, regulator and gage in the air line leading to the air manifold tank on the air cleaner. These items, supplied by others, should be placed in a convenient location for easy service.

NOTE: These components should be sized to the maximum system requirement of 1.1 SCF per pulse at 100 PSIG supply pressure and all connections sealed with thread sealing tape or a pipe sealant.

MAGNEHELIC GAGE OPTION

The magnehelic gage indicates the pressure drop across the cartridge filters, any optional pre-filters and any adjoining air inlet ducting. A metal mounting bracket is provided with the gage. The gage should be mounted in the vertical position and preferably at eye level near the cleaning (air pulse) control. When mounted, interconnect the unit to the "Low" port of gage with the fitting and tubing provided. To complete the connection at the unit, remove the hole plug from the 5/16" hole located in the top of the unit cabinet on the air inlet side. If it is necessary to gain access to the hole on the inside of the cabinet, remove the filter cartridges closest to the hole.

The "High" port on the gauge is vented to atmosphere. Refer to Figures 4 and 7 and the instructions included with the gage.

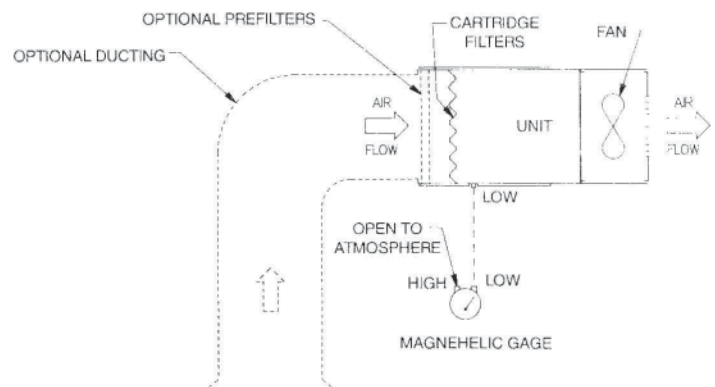

FIGURE 7

ELECTRICAL

The blower motor operates on 208-230/460 volt, 60 cycle, 3 phase power. Remove the air discharge grille and wire the motor in accordance with the connection diagram on the motor data plate and the governing electrical codes.

OTE: The cleaning (air pulse) control requires 120V power and is usually wired in parallel with the motor starter coil.

When the cleaning cycle is initiated, a sequential timer controls the air solenoid valves causing the air to pulse (a back rush of cleaning air) to the filter cartridges. Normally the sequential timer is wired in parallel with the low voltage coil in the magnetic motor starter causing the pulse cleaning cycle to take place when the unit blower is running.

If the cleaning cycle is to take place with the blower not running (or off-line), care should be taken to insure the contaminants are not pulsed off the cartridge filters and escape into an undesired area. Depending upon the makeup of the contaminants, pre-filtration and the arrangement of any ducting, it may be necessary to install dampers on the cabinet inlet.

The sequential timer may be initiated manually (with the blower on or off-line), a 7 day time clock or a pressure switch gage. Refer to the typical installation figure 4 and the applicable wiring diagram, Figures 9, 10, 10A, 11, 12 or 13 then complete the wiring as shown.

The blower should rotate in a clockwise rotation. The rotation can be viewed through the air discharge grille in the blower compartment. When the wiring is complete, electrically "bump" the blower motor to check the rotation and correct if necessary by interchanging any two of the three wires-T1, T2 or T3- in the motor starter.

NOTE: The electrical work must be performed by qualified personnel and in accordance with local codes.

OPERATION

1. Turn the fan "on" and check the rotation. Rotation should be clockwise as viewed from the air discharge grille, ("blowing outward"). Correct if necessary by interchanging any two of the three wires - T1, T2 or T3 - leading to the fan motor in the motor starter.
2. Be sure the pulse cleaning control switch is in the "off" position and turn on the compressed air supply. Adjust the pressure to 80 PSIG.
3. Open the cover to the sequential timer and set the "on" time for 0.1 second and the "off" time for 5 to 10 seconds. Connect the red jumper wire to program pin 4 or to the pin corresponding to the last terminal used on the terminal board.

4. Check the operation of the air valves by closing the cleaning (air pulse) control switch. The valves should open and close continuously and in sequence in accordance to the time settings. When all of the valves have operated several times, open the cleaning (air pulse) control switch.
5. **Note:** The following step covers pretreatment of the filter cartridges. The cartridges shipped with the unit have been pretreated.

With the fan running, pretreat the filter cartridges with the air filter conditioning agent supplied. Simply hold the exposed conditioner near the air intake of the unit and allow the fan to pull it to the filtering media. Use 2 lbs. per cartridge. The pretreatment improves the collection and cleaning efficiency of the cartridges.

6. The unit is now ready for operation. Note the pressure drop reading on the magnehelic gage. This reading is a base reference reading with clean, preconditioned cartridges.

CLEANING CYCLE

1. As contaminant is collected the system static pressure will continue to increase until there is a loss in the contaminant capture. If the installation includes a Magnehelic gage the pressure drop reading should be noted and at this time the filter elements should be cleaned. (Subsequent cleaning and/or filter replacement should take place just prior to the noted loss in contaminant capture.) The length of time required to arrive at this condition is dependent upon the type and the amount of contaminant.
2. Start the cleaning cycle by closing the cleaning pulse control switch. Normally, cleaning is accomplished during plant nonscheduled work hours or between shifts and the unit fan remains running during the cleaning cycle.
3. During the cleaning operation a reduction in the pressure drop will be noted. When an equilibrium is obtained, open the cleaning control switch. The unit is now back in normal operation.
4. If the installation includes a pressure switch or 7-day timer option settings should be made in accordance with the above.
5. In the event the cleaning cycle is to take place with the blower not running (or off-line) refer to paragraph three under ELECTRICAL.

ADJUSTMENTS

COMPRESSED AIR

Compressed air pressure above 80 PSIG should only be used when the equilibrium pressure drop exceeds 5 inches.

Under these conditions increase the pressure in 5 PSIG increments. Allow sufficient "off time" (5 sec. or more) for the pressure drop to stabilize after each 5 PSIG increase.

NOTE: Do not increase the pressure beyond 100 PSIG. Damage to the filters may result.

The 0.1 second time "on" setting should not be altered. Longer pulse durations do not aid in cleaning.

AIR FLOW

This unit is equipped with a direct drive motor blower assembly. For all installations an impinger (spark arrestor) is normally used. An impinger with a greater airflow restriction is available to further reduce the CFM capacity of the motor blower.

NOTE: A high static blower assembly which can exceed 6" total static @ 2000 plus CFM is available.

NOTE: Do not increase the air flow beyond 3000 CFM in unducted applications. Damage to the filters may result.

SERVICE

CAUTION:

Before servicing any portion of the air cleaner:

1. Disconnect and lock out electrical power.
2. Shut off and bleed compressed air supply.

CARTRIDGE REMOVAL AND REPLACEMENT

NOTE: Wear goggles and a NIOSH approved respirator or dust mask when servicing or replacing cartridge filters!

1. Open access door.
2. Remove wing nut and cartridge filter end caps.
3. Move cartridge filter slightly up and down to break the rear gasket seal.
4. Rotate the cartridge 1/2 turn to permit any loose dust to fall from top of element.
5. Slide the filter out of the compartment.
6. Clean any dust deposits from the rear gasket seal area to assure a positive seal for the replacement cartridges.
7. Remove excess dust from bottom of compartment by brushing out or by vacuuming.
8. Install new cartridges, replace and secure end caps and close door.

**FILTER COMBINATION
PRECONDITIONED CARTRIDGE WITH EITHER**

- 1. NO PRE-FILTER**
- 2. PERFORATED BAFFLE OR**
- 3. 2" ALUMINUM MESH PRE-FILTER**

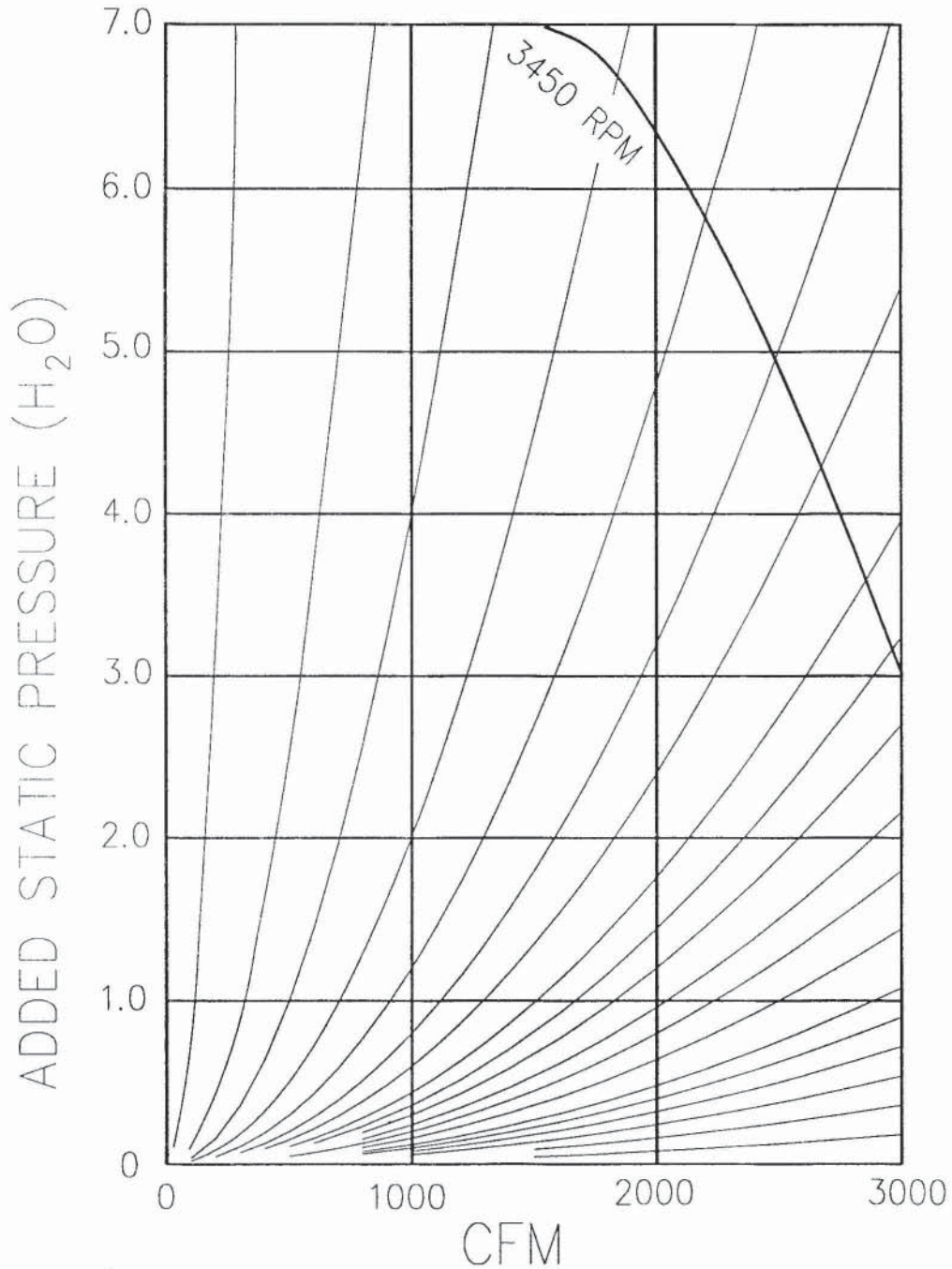

DIRECT DRIVE - HIGH STATIC PERFORMANCE CURVE

**FILTER COMBINATION
PRECONDITIONED CARTRIDGE WITH EITHER**

- 1. NO PRE-FILTER**
- 2. PERFORATED BAFFLE OR**
- 3. 2" ALUMINUM MESH PRE-FILTER**

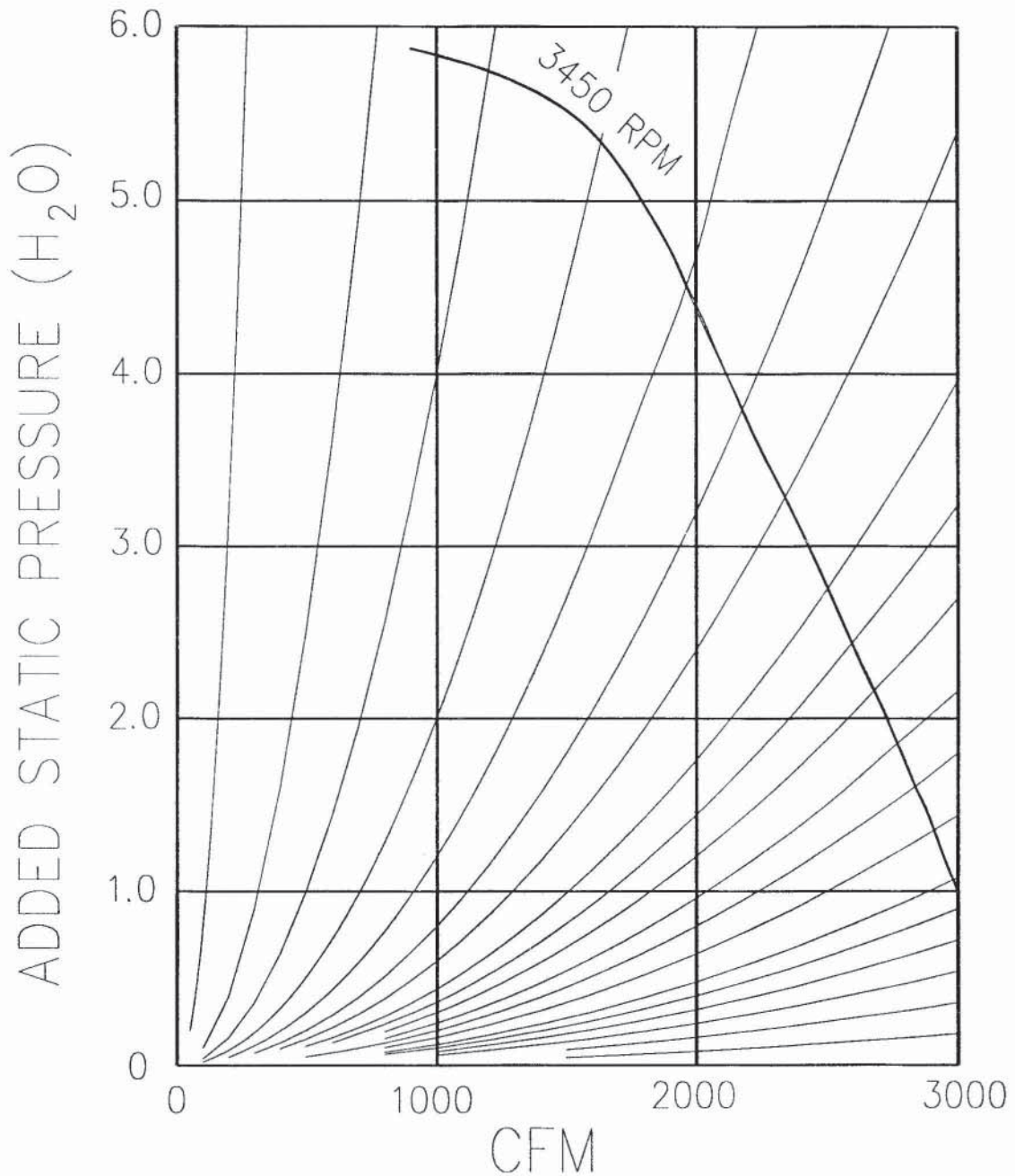

DIRECT DRIVE - STANDARD PERFORMANCE CURVE

**FILTER COMBINATION
PRECONDITIONED CARTRIDGE WITH EITHER**

- 1. NO PRE-FILTER**
- 2. PERFORATED BAFFLE OR**
- 3. 2" ALUMINUM MESH PRE-FILTER**

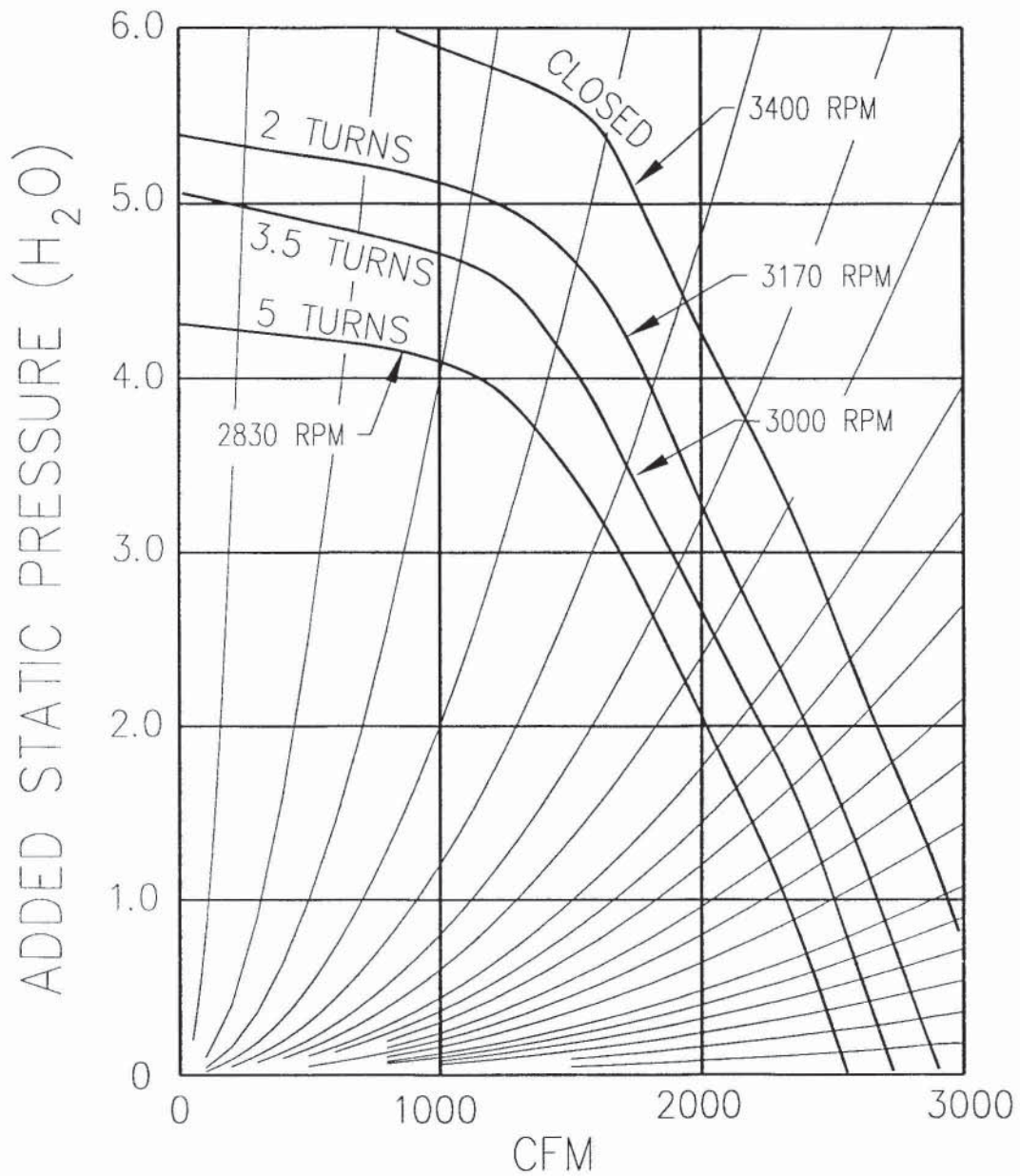

VARIABLE DRIVE - PERFORMANCE CURVES

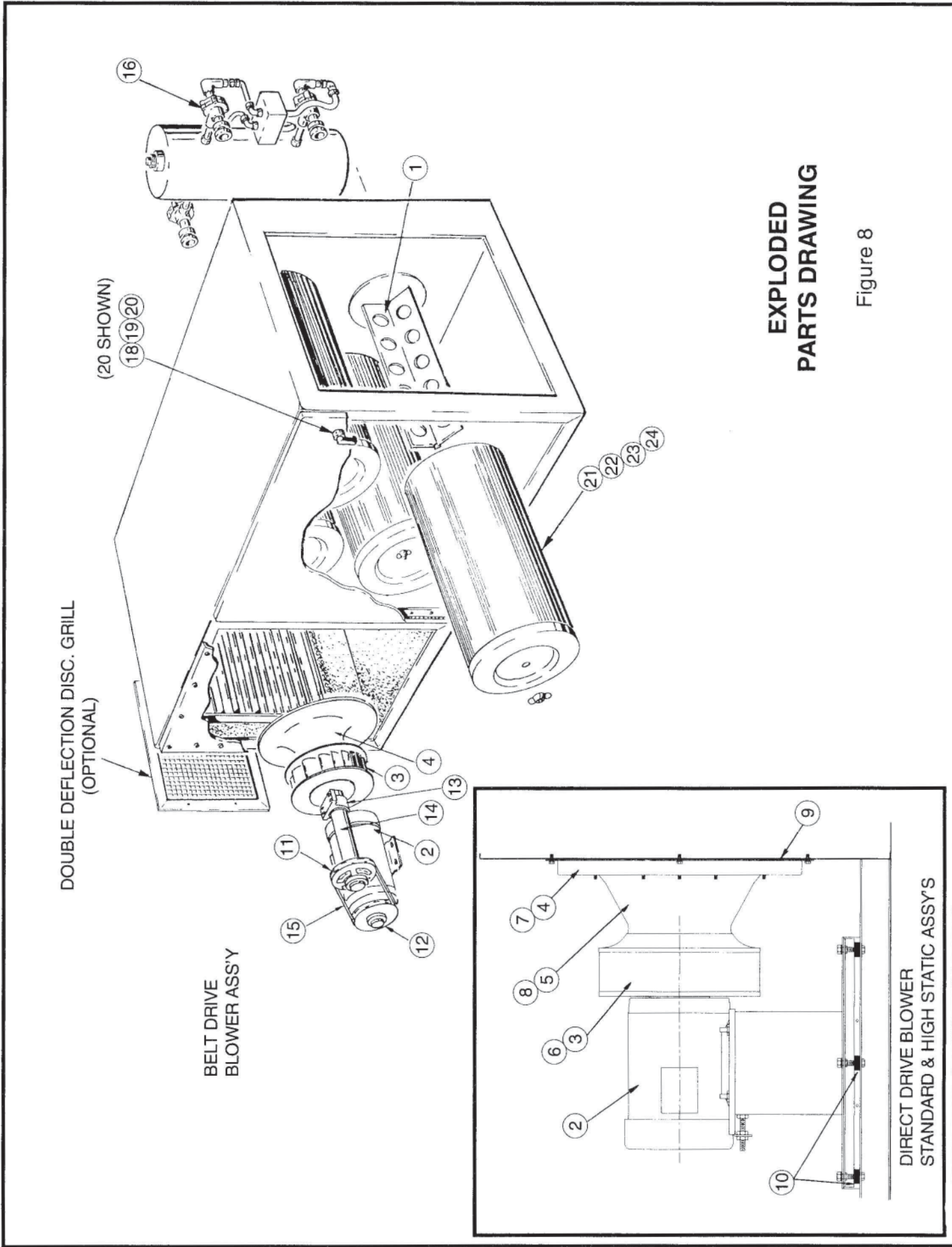

DOUBLE DEFLECTION DISC. GRILL
(OPTIONAL)

BELT DRIVE
BLOWER ASS'Y

**EXPLODED
PARTS DRAWING**

Figure 8

DIRECT DRIVE BLOWER
STANDARD & HIGH STATIC ASS'YS

UNIT COMPONENTS

REF. KEY	QTY. /UNIT	PART NUMBER	DESCRIPTION
1	4	442285-001	Filter Mounting Bracket Assembly
2	1	345515-049	Motor, 5 H.P., 230-460V/60Hz/3ø
3	1	245583-014	Blower Wheel #135, 100% width
4	1	449213-001	Inlet Cone Mtg. Panel
5	1	345585-003	Inlet Cone #135 Size
6	1	249031-001	Blower Wheel #150, 75% width
7	1	449213-002	Inlet Cone Mtg. Panel
8	1	345585-004	Inlet Cone #150 Size
9	1	249210-001	Inlet Stabilizer Grille (Direct Drive Blowers)
10	6	146229-001	Equipment Mount (Rubber Isolator) (Direct Drive Assemblies)
11	1	124053-059	Blower Sheave, 6.0 P.D.
12	1	125699-025	Motor Sheave, 4.7-5.7 Variable P.D.
13	2	243761-001	Pillow Block Bearing 15/16 Bore
14	1	245584-004	Blower Shaft 15/16 Dia.
15	1	234887-037	V-Belt, 47.3 Pitch Length
16	4	142397-001	Diaphragm Air Valve 3/4"
17	1	142399-001	Sequential Timer (item 10 on page 3)
18	2	142696-055	Hex Washer Head Screw 1/4-20 x 1 1/4 long
19	2	237911-006	Self Retaining Nut 1/4-20
20	2	334562-003	Lift and Turn Latch
21	4	242423-002	Cartridge Filter - Cellulose Media
22	4	242424-002	Cartridge Filter - Cellulose/Polyester
23	4	248300-002	Cartridge Filter - Fire Retardant Media
24	4	249553-002	Cartridge Filter - Membrane Coated
25	8 Lb.	242691-001	Filter Pre-coat (conditioner)

} Standard Blower Direct Drive

} High Static Direct Drive

} Belt Drive
Blower Assembly

} As Specified

**OPTIONAL COMPONENTS - ACCESSORIES
NOT SHOWN**

PART NUMBER	WT. LB. EA.	DESCRIPTION
442302-001	35	Hopper with Slide Gate
242692-001	0.6/Ft.	6" Flex Hose (Specify length required)
242690-001	10	55 Gallon Drum Connector
3000-8000-00	45	Source Capture Plenum with 14" Collar
224451-018	7	Aluminum Mesh Pre-Filter
225822-006	13	Perforated Metal Pre-Filter
342294-001	21	Spark Resisting Pre-Filter (Standard Impinger)
342294-002	21	Spark Resisting Pre-Filter (Reduced Airflow Impinger)
24-8002-0002	65	Flex Source Pick-Up Arm, 8" Dia.
24-8400-0001	50	Dual Arm Plenum
442712-001	8	Pressure Switch/Gage
146302-001	1.1	Magnehelic Gage (Shown on Page 3)
342750-001	2	7-Day Timer Control
344140-001	25	*Side Discharge Kit
349216-002	25	*Muffler Kit
242372-001	2.5	Double Deflection Discharge Grille
349208-001	20	*Discharge Grille Adapter

*Requires use of Double Deflection Discharge Grille Part No. 242372-001

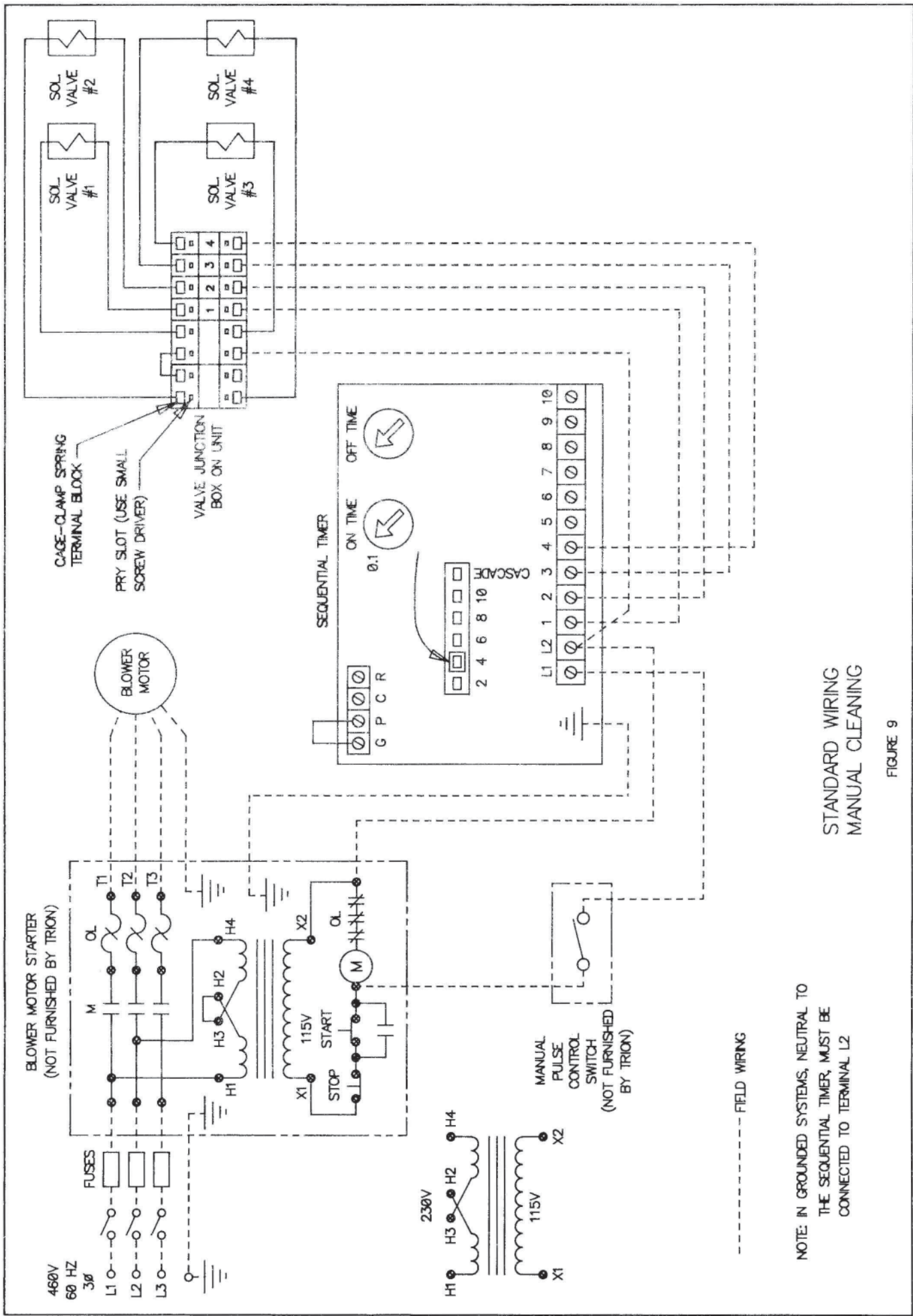

NOTE: IN GROUNDED SYSTEMS, NEUTRAL TO THE SEQUENTIAL TIMER, MUST BE CONNECTED TO TERMINAL L2

STANDARD WIRING MANUAL CLEANING

FIGURE 9

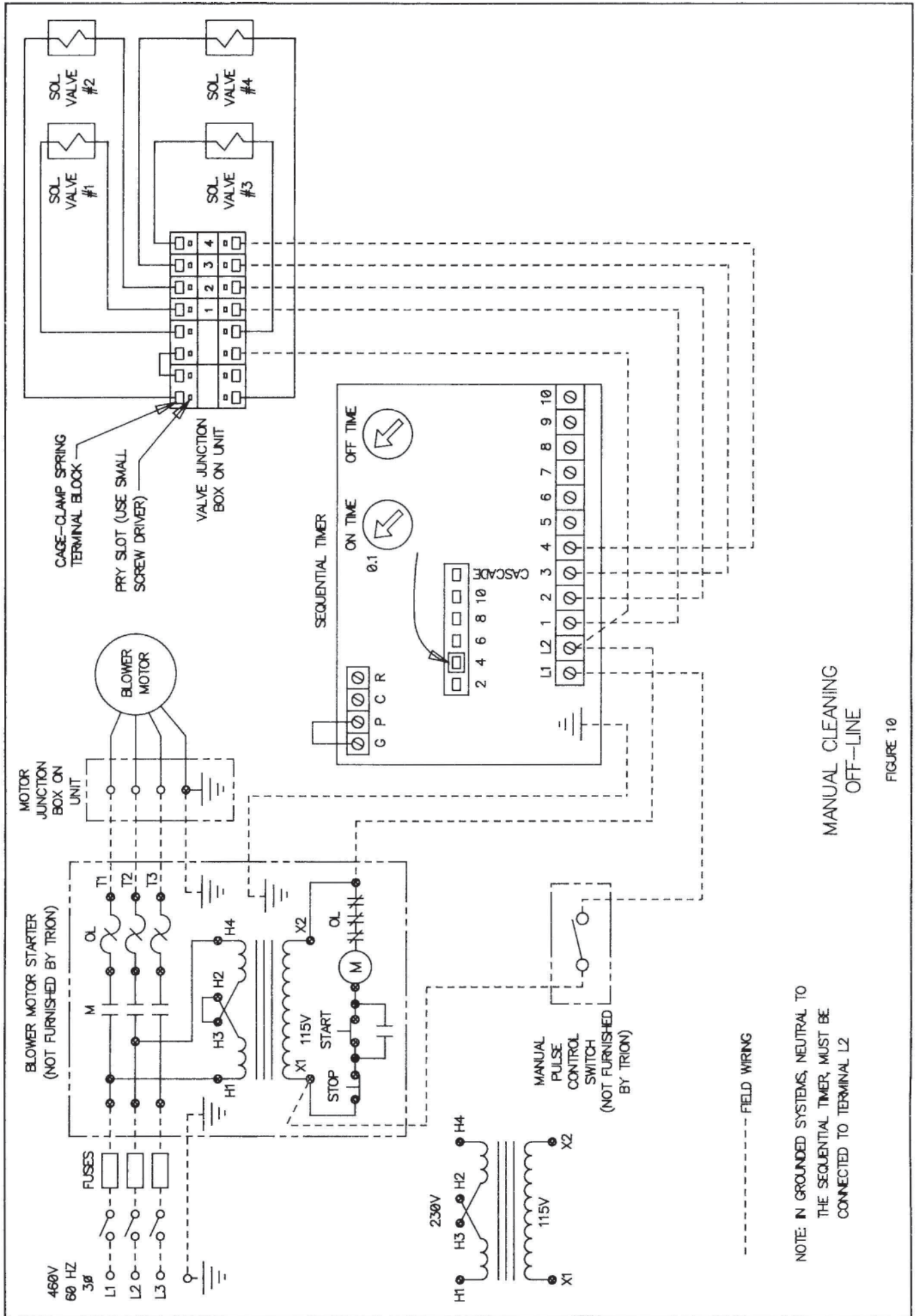

MANUAL CLEANING
OFF-LINE

FIGURE 10

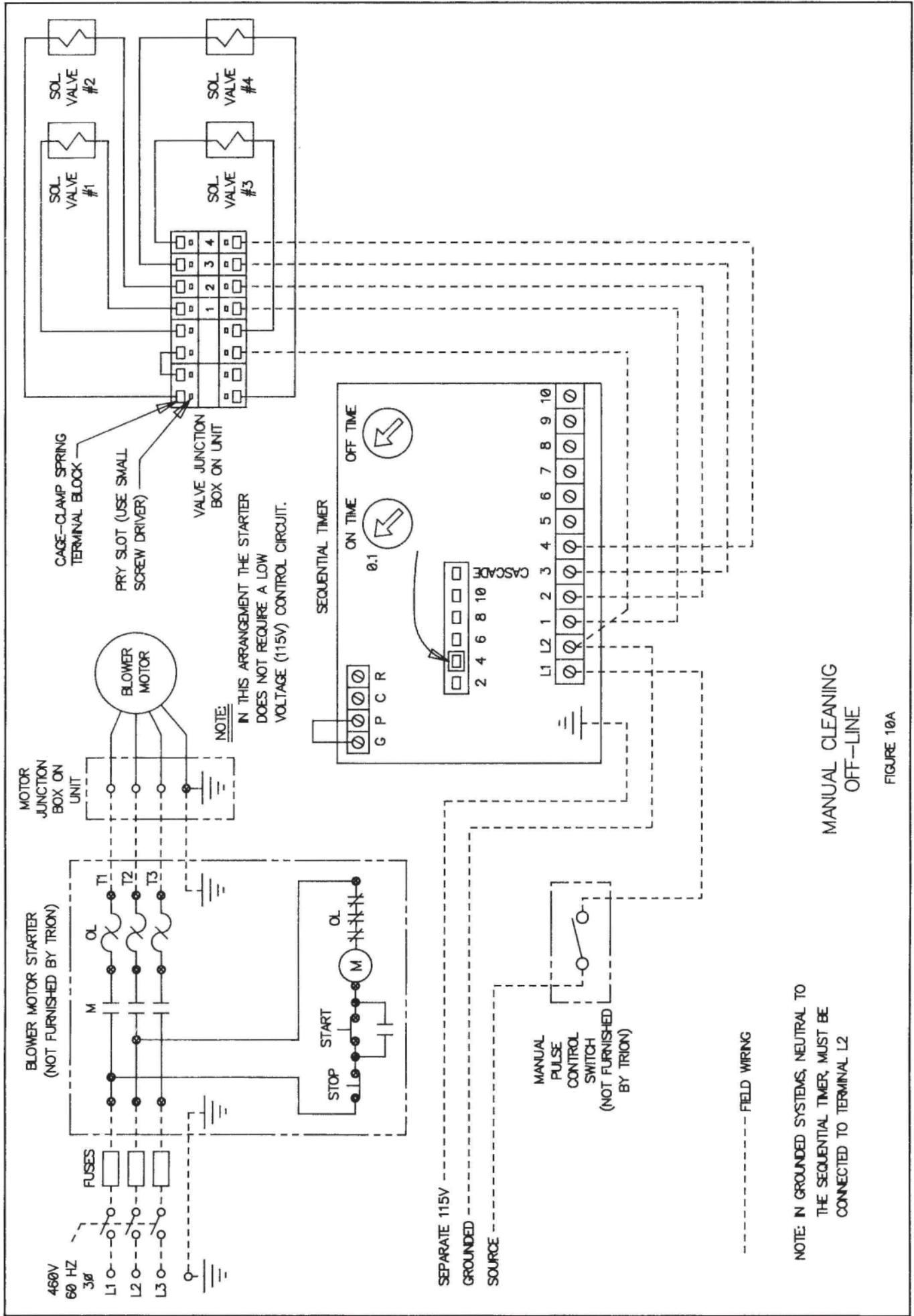

MANUAL CLEANING OFF-LINE

FIGURE 10A

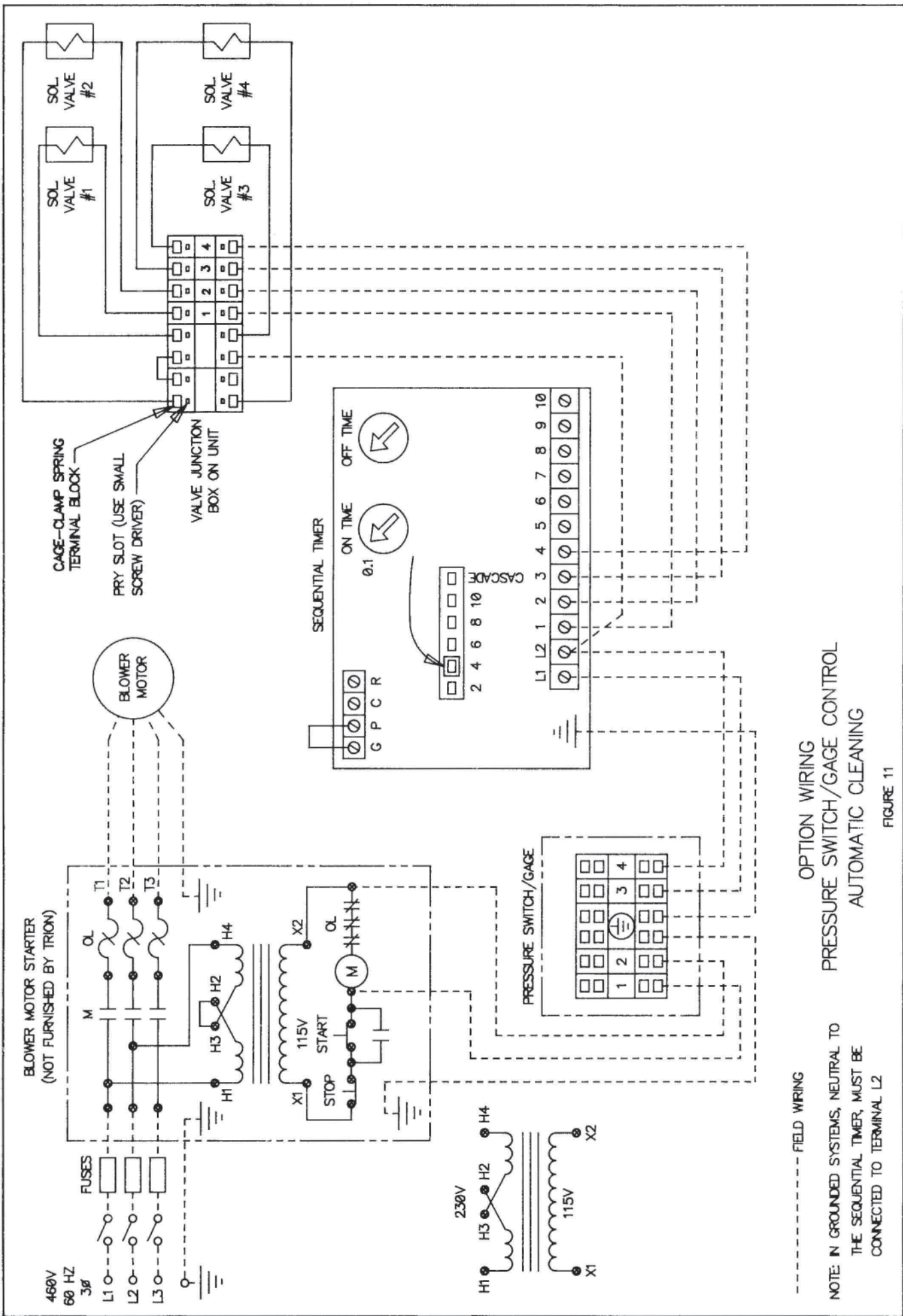

OPTION WIRING
 PRESSURE SWITCH/GAGE CONTROL
 AUTOMATIC CLEANING

FIGURE 11

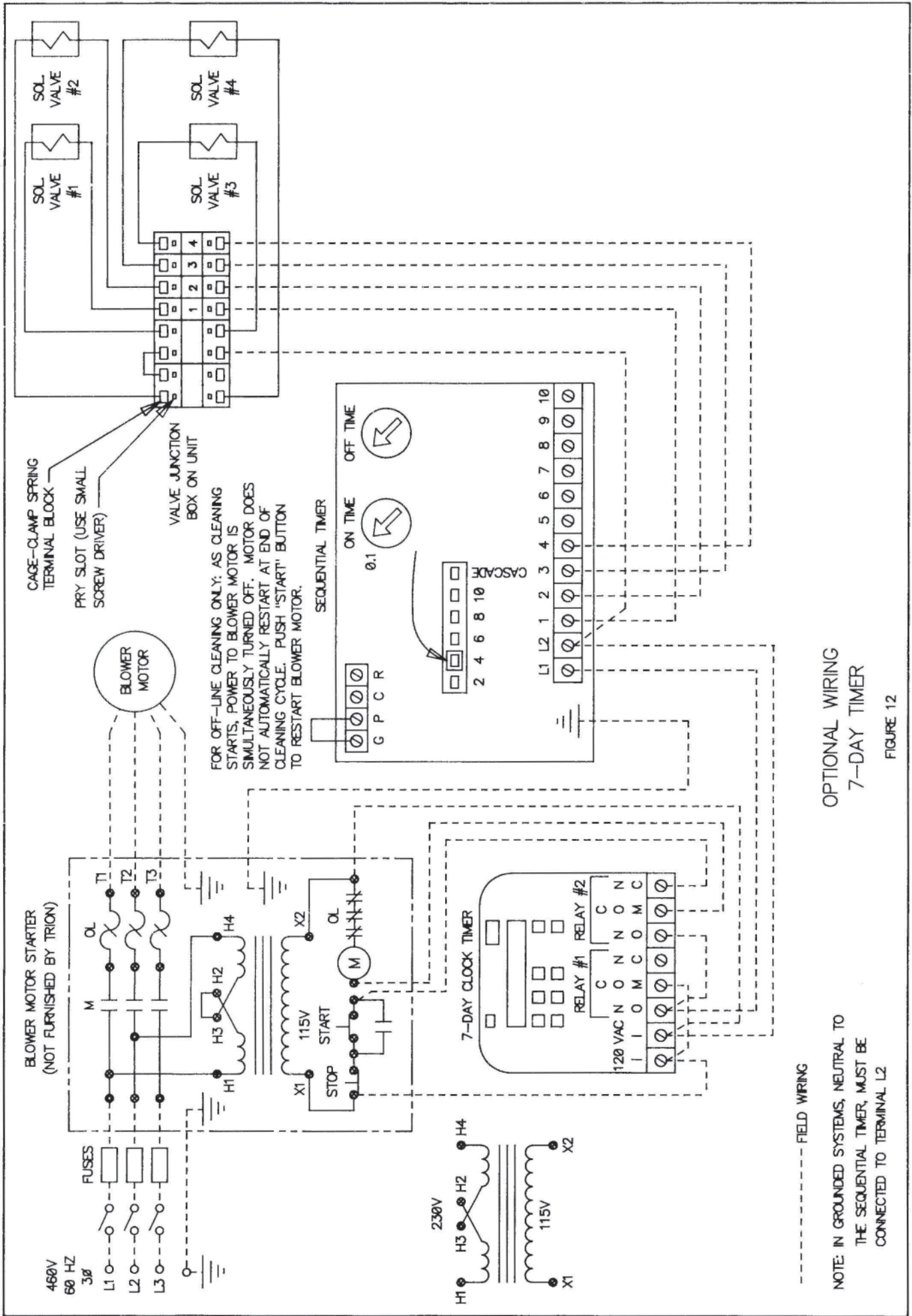

OPTIONAL WIRING
7-DAY TIMER

FIGURE 12

Contact Information

Trion

101 McNeill Road
Sanford, NC 27330 U.S.A.
Tel. 800 884 0002
Fax 919 777 6399
Email: customerservice@trioninc.com

Trion LTD.

The Cavendish Center
Winnall Close
Winchester, Hampshire
SO23 OLB, UK
Tel. 440 1962 840465
Fax 44 0 1962 828619
Email: info@trion.co.uk

