



READ & SAVE THESE INSTRUCTIONS

Herrtronic® MD Series

Installation, Operation, & Maintenance

TABLE OF CONTENTS

SECTION I WARRANTY

Warranty 3

SECTION II UNIT OPERATION

Herrtronic MD: Basic Operation 4
 Types of Control 5

SECTION III INSTALLATION INSTRUCTIONS

Allowable Operating Conditions 6
 Mounting 6
 Plumbing 6
 Supply Power 7
 Steam Distributor Pipes 8
 Steam Distributor for Ducted Systems 9
 Controls 10
 Control Circuit Connections 10
 External Off Switch 11
 Remote Alarm Output 12
 Unit Networking 12

SECTION IV OPERATION INSTRUCTIONS

Operating Instructions 13
 Programming 14
 Start-up with Check List 16
 Diagnostics 19
 System Fault Conditions 20
 Maintenance 20

SECTION V TROUBLESHOOTING GUIDE

General Maintenance Notes 22
 Operating The Humidifier Without External Controls 22
 Unit Detected Faults: (Red "Service" Light On) 24
 Non-Fault Indicated Problems 25
 Troubleshooting Without Unit-Detected Faults 27
 Output / Input of Terminal Strips and Terminal Block 28

I. WARRANTY

Limited 2-Year Warranty

Seller warrants the equipment of its manufacturing to be free from defects in workmanship and material for a period of 24 months after shipment or 24 months after initial commissioning, whichever occurs first. This warranty is limited, however, to the repair or replacement of defective equipment, which is returned, freight prepaid, to Seller's factory.

This limited warranty does not apply to any part or component that is damaged in transit or when handling, has been subject to misuse, negligence or accident, has not been installed, operated or serviced according to Seller's instructions, or has been operated beyond the factory-rated capacity or has been altered in any way.

Seller's liability is limited to replacement of defective parts or components and does not include any cost of labor (including, but not limited to, labor required to remove and/or reinstall any defective part) other than TRION/HERRMIDIFIER factory labor.

Each of the Herrtronic series of steam generating humidifiers contains a plastic steam generating cylinder that is to be considered a routinely disposable part to be changed at regular maintenance intervals at the user's expense. This steam generating cylinder is not covered by this Warranty. If, after the first installation of your Herrtronic humidifier, you feel the steam generating cylinder is not operating normally, you should contact your TRION/HERRMIDIFIER Representative with an explanation of the problem. However, in the continuing operation of this humidifier, replacements of this part are your responsibility as part of routine maintenance.

TRION/HERRMIDIFIER shall not be responsible for loss of use of any product, loss of time, inconvenience, or damage to other equipment, or any other indirect or consequential damage with respect to property whether as a result of breach of warranty, neglect, or otherwise.

THE WARRANTIES AND LIABILITIES SET FORTH ARE IN LIEU OF ALL OTHER WARRANTIES AND LIABILITIES, EXPRESSED OR IMPLIED, IN LAW OR IN FACT, INCLUDING IMPLIED WARRANTIES OF MERCHANTABILITY AND FITNESS FOR PARTICULAR PURPOSE.

The foregoing shall constitute the total liability of seller in the case of defective performance of all or any of the equipment or services provided to Buyer. Buyer agrees to accept and hereby accepts the foregoing as the sole and exclusive remedy for any breach or alleged breach of warranty by Seller.

II. UNIT OPERATION

Herrtronic MD: Basic Operation

Controlled humidification requires a very precise control system. The Herrtronic MD utilizes a microprocessor to monitor performance and maintain humidity. Further, the Herrtronic MD evaluates the operation and alerts the operator to problem conditions and prevents undesirable operation:

1. **Start-up:** On initial start-up (prompted by a call-for-humidity), the fill valve opens allowing water to enter the cylinder. When the water level rises to the electrodes, current will flow and the water will begin heating. As the water temperature increases, its conductivity also increases, accelerating the rate of temperature increase. When the output reaches the “capacity set point,” the fill valve closes. The output capacity may continue to rise slightly beyond the “capacity set point.” As the water boils away, the water level falls. This results in a reduction in output capacity.
2. **Normal Operation:** Upon achieving “capacity set point,” the system begins operation in a steady state mode. Output capacity slowly decreases until the elapsed “cycle time” opens the fill valve to replenish the water level

until the “capacity set point” output is achieved. As the mineral concentration in the water increases, the water conductivity also increases. Accordingly, the rate of boiling increases. Eventually, the rate of boiling reduces the output capacity below the “low drain threshold” before the “cycle time” initiates the fill cycle.

At this point, the drain valve opens discarding the mineral laden (highly conductive) water, replacing it with fresh water, that lowers the mineral concentration until the system is restored to the steady state mode.

The steady state operating mode continues with small increases in the water level to maintain output capacity (by exposing new electrode surface).

3. **End-of-Cylinder Life:** Steady State operation continues with “fill and boil” and periodic drain cycles with ever increasing water levels. Eventually, the water level reaches the cylinder full electrode, representing the maximum allowable water level inside the cylinder. The system output begins to decrease since there is no new electrode surface to expose. If the system operates continuously without achieving “capacity set point,” an “end of cylinder life” fault will be displayed.

HERRTRONIC MD: Basic Operation

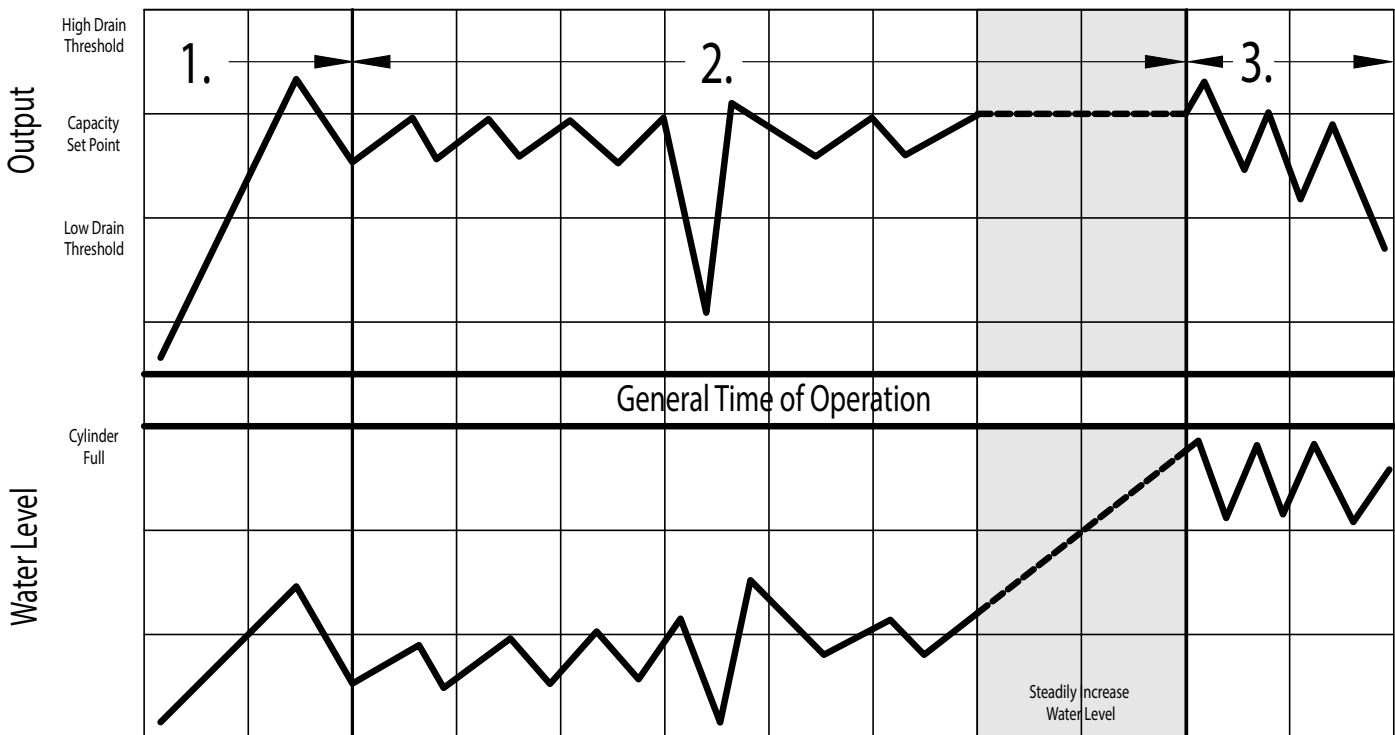

Types of Control

The Herrtronic MD System is available with (3) types of control ---(1) On/Off, (2) Proportional, (3) Proportional + Integral:

1. On/Off – Humidity is sensed by a humidistat that provides an On/Off input to the humidifier. Humidity varies above and below the setpoint based on the tolerance and accuracy of the humidistat.
2. Proportional – A proportional controller produces a signal (ohms, volts DC, or milliamps DC) corresponding to the difference between the control humidity and the humidity setpoint. The humidifier’s output increases as this difference (and signal) increases. Humidity variations will be smaller than with “On/Off” control and the control humidity will be maintained within the bandwidth, tolerance, and accuracy of the controller.

3. Proportional + Integral – Over a repeating time period the “P+I” control simply evaluates the difference between the average control humidity and the control humidity setpoint and adjusts the bandwidth to minimize the “offset.” Optimal control is attained in most cases with this alternative.

NOTE

If your application is unique or water is excessively “clean” or “dirty,” consult TRION/HERRMIDIFIER for assistance in matching your humidifier, water treatment, and its control scheme to your application!

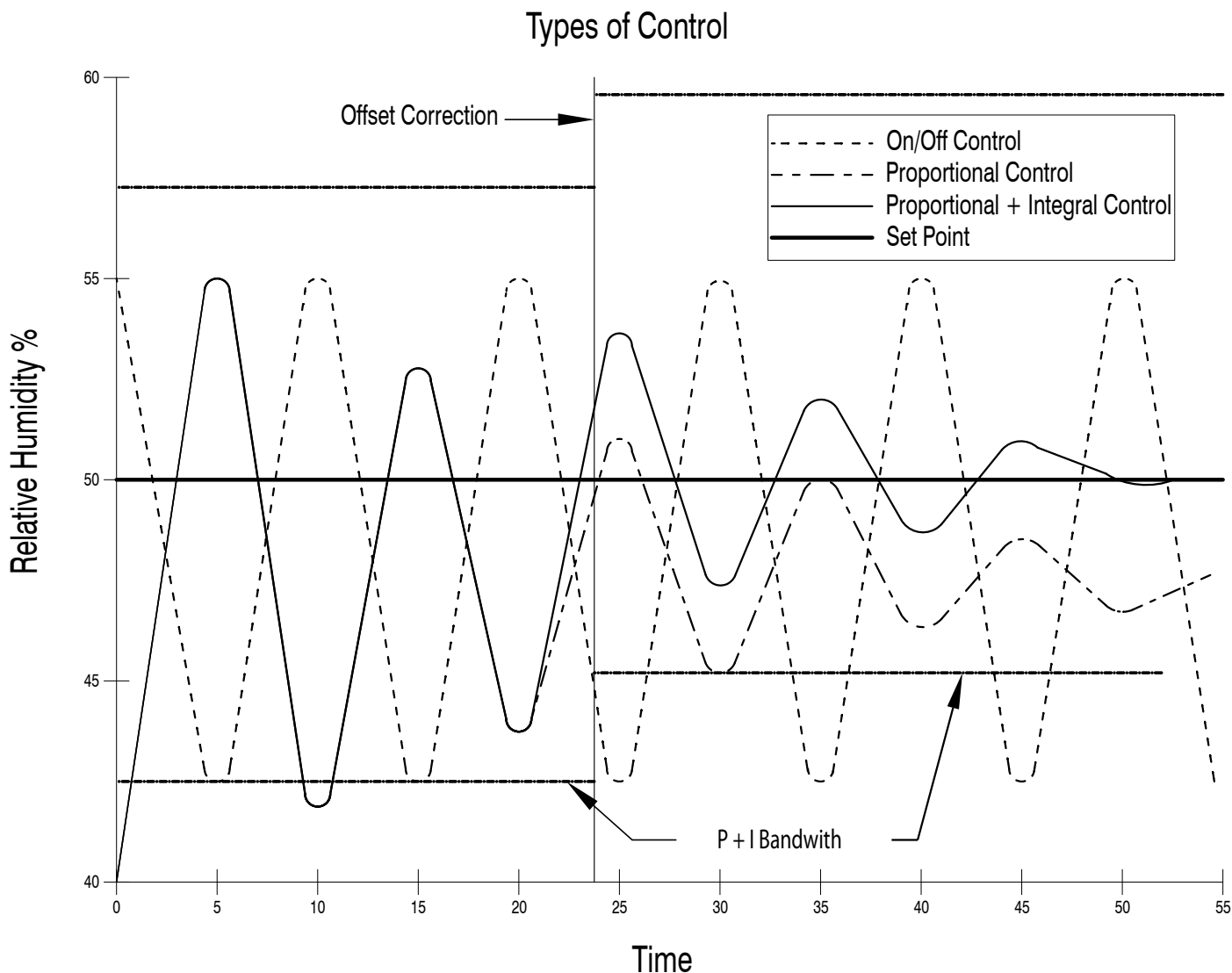

III. INSTALLATION INSTRUCTIONS

Allowable Operating Conditions:

- Ambient Temperature: 40°F - 120°F (4°C - 50°C)
- Ambient Relative Humidity: 0% to 90%
- Line Voltage: -15% to +10% of Nominal
- Frequency: 50/60 Hz.
- Supply Water Temperature: 40°F-100°F (4°C-38°C)
- Supply Water Pressure: 20-100 psig
- Supply Water Conductivity:
 - 70-1000 mincromho (on-off control)
 - 200-1000 micromho (prop or P + I control)

(See Figure 30 & 31 on page 27 for alternative water conditions)
 Maximum Duct Static Pressure: 5" MDM, 7" MDS/MDD units

NOTE: If units are mounted in outdoor enclosures, conditions inside enclosure must be maintained as shown above.

Mounting

The cabinet is designed to safely contain the working components of the Herrtronic MD humidifier and dissipate heat to protect the electronics. Herrtronic MD Series electronic steam humidifiers, room distribution units, steam pipes, and any accessories should be located in a manner to facilitate routine inspection and any necessary maintenance. The unit should not be located above (such as false ceilings) or around valuable property, where a malfunction could cause damage. Correct positioning of the Herrtronic MD humidifier is important to allow for proper operation and easy maintenance. Minimum clearance around the cabinet should be maintained as follows:

Unit Clearances By Model			
Unit Series	MDM 5-30 Lbs.	MDS 10-100 Lbs.	MDD 110-250 Lbs.
Left	2"	2"	2"
Right	20"	20"	20"
Top	12"	12"	12"
Bottom	10"	10"	10"

Four lag bolts, (2) 5/16" and (2) 1/4", are supplied with the MDS and MDM units which are designed to be secured to a wall. Install the top two lag bolts (5/16") according to the dimensions in Figure 1. Hang the unit on the wall, and then install the bottom two lag bolts (1/4") and secure all four bolts. Be sure the unit is level and mounted directly to the wall to wood studs at least 2" thick (or equivalent).

Operating weights are as follows:

- MDM - 82 lbs.
- MDS - 131 lbs.
- MDD - 258 lbs.

WARNING!

Do not mount any controls inside the unit or tap power from any location in the unit, except as stated in these instructions. Do not place objects near the cabinet. Do not attach to dry wall without studs.

NOTE

To mount the Room Distribution Unit, refer to the "supplemental" RDU Installation Instructions.

Plumbing

To make the necessary connections for water fill and drain, the following steps are required: (refer to Figure 2 for drain location)

1. Install an external shutoff valve between the water supply and the humidifier for ease in servicing the unit.
2. Connect water supply to 1/4" compression fitting on the bottom of the cabinet.

CAUTION!

Do not use reverse osmosis or demineralized water treatment without first consulting the factory. This water may not be sufficiently conductive to allow proper operation. Consult factory if water is outside the range of allowable conductivities. Do not use hot water.

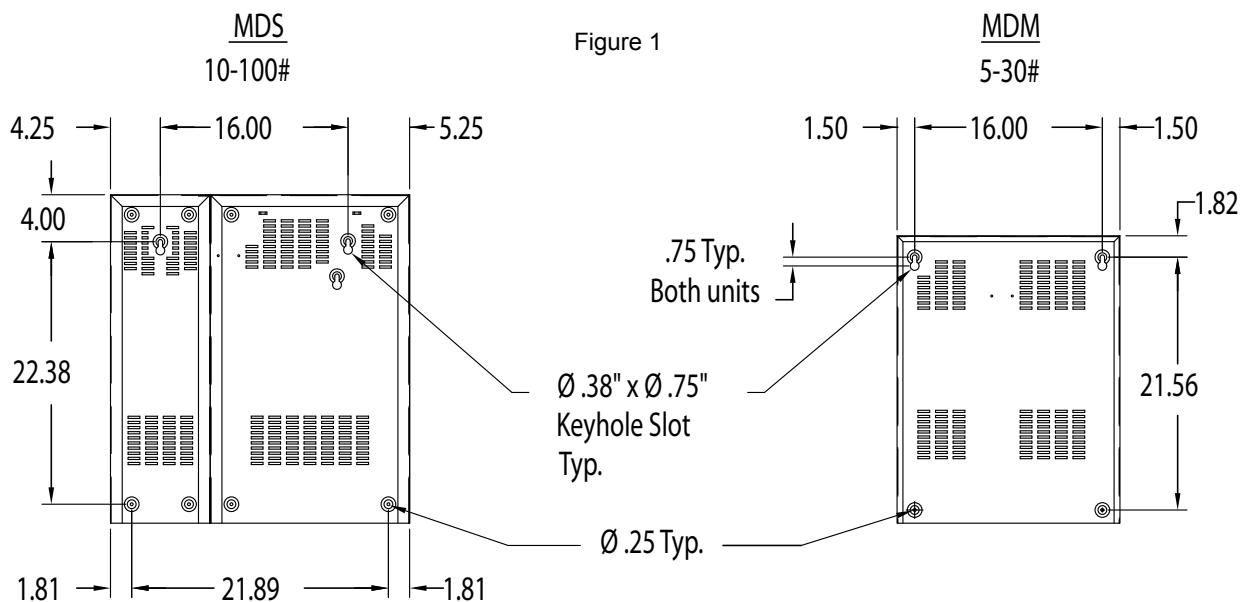

Figure 1

Installation, Operation, & Maintenance Manual

3. Connect the $\frac{3}{4}$ " tube from the accessory pack to the drain reservoir. Cut hose to necessary length.

WARNING!

Be sure that the $\frac{3}{4}$ " drain tube is not kinked or bent in a manner to prevent free flowing drainage from the drain reservoir to the drain pipe.

4. Insert the other end of the tube into a minimum 6" length of $1\frac{1}{4}$ " minimum I.D. copper line. The balance of the drain line should be $1\frac{1}{4}$ " I.D. minimum with a minimum $\frac{1}{8}$ " per foot slope. (See Figure 2)

WARNING!

If the drain line is exposed, it is recommended that it be insulated for safety. Do not use PVC drain line unless "Drain Tempering" is enabled (see page 16-17).

NOTE

Inlet water pressure must be in the range of 20-100 psig. Consult the factory if you are outside this range. Softened water may be used but requires that the low drain threshold be adjusted (refer to Fig. 30 page 27). Drain water can be tempered to lower its temperature (refer to page 16).

Figure 2

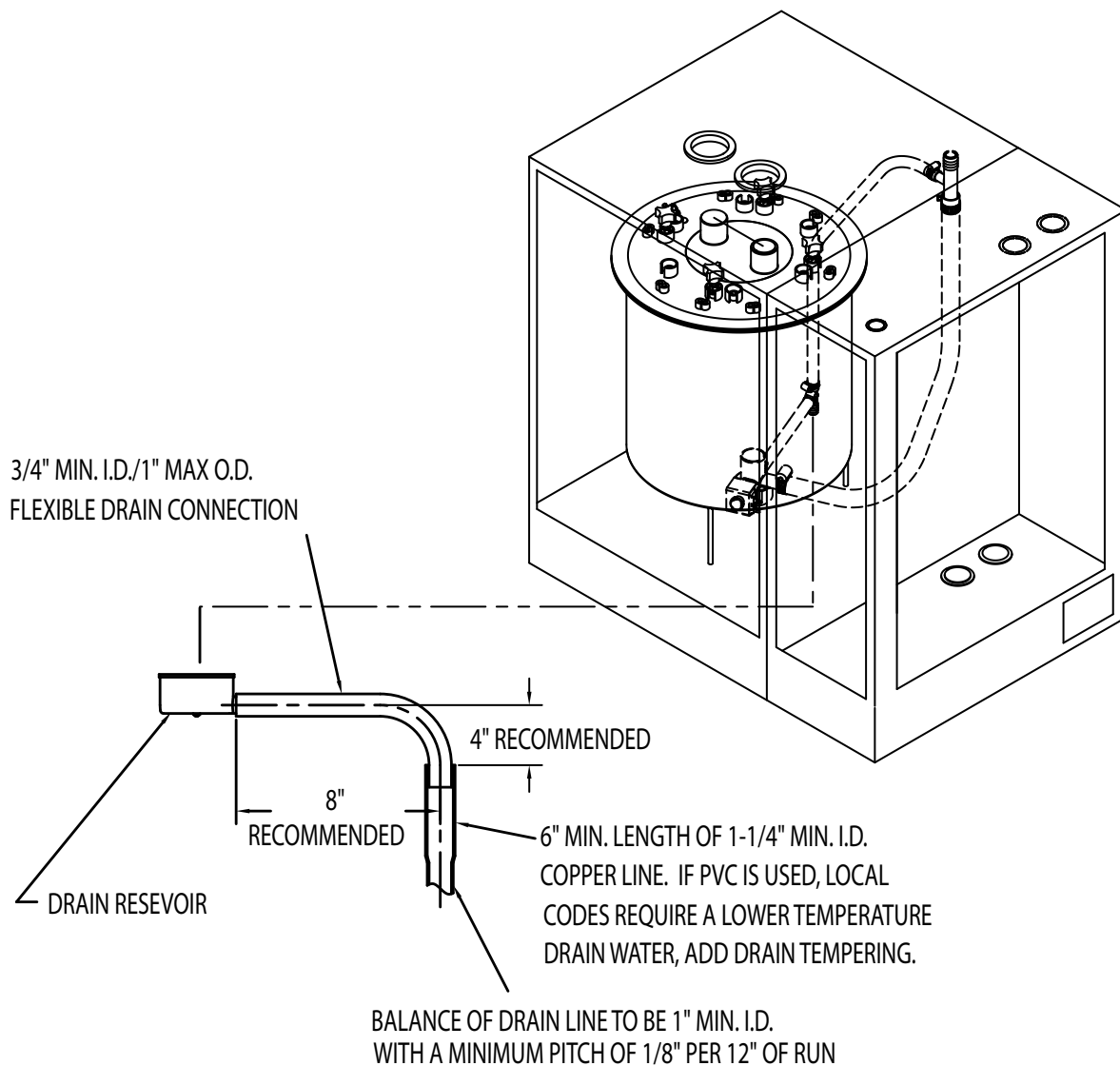

Installation, Operation, & Maintenance Manual

Supply Power (See Electrical Characteristics Table Below)

1. Ensure that adequate service is available to carry 125% of rated amp level.
2. Field wiring of the main power supply is connected directly to the contactor (single contactor units) or to a power distribution block (multiple contactor units) located in the electrical compartment. A ground lug is provided for the ground wire.
3. Install external overcurrent protection and provide wiring in accordance with the NEC, state and local code.
4. Power supply must be "clean"; free of spikes, surges and sags; -15% to +10% of Nominal. Ground should be a true earth ground.

Steam Distribution for Ducted Systems

Each steam cylinder requires at least one outlet for steam via a duct distributor or Room Distribution Unit. (See RDU supplement for Room Distribution Unit)

Steam Distributor Pipes

TRION/HERRMIDIFIER supplies stainless steel duct distributor pipe(s) for use in injecting pure steam into ducts. Refer to Figure 3, 4, or 5 for proper placement. A minimum of 3' clearance downstream is required for most applications. However, differing psychrometric conditions may require a greater or lesser steam absorption distance. Consult the factory if you have any questions or need to exchange your standard distribution system for a rapid absorption CS-Series Distribution system.

NOTE

- The rubber steam hose carries steam to the distributor pipe and condensate back to the unit. It must have an 8% (1" per foot) pitch back to the unit. Support the steam hose so it will maintain the proper pitch when in operation or at rest.
- If any low spots are in the steam line or the unit is mounted higher than the distribution system, spitting may occur from the steam distribution pipes. A condensate separator (EST-250) is available from the factory. (See Fig. 6)
- If you must split the discharge of one steam outlet into two ducts with the same static pressure, a "Y" connector (EST-255) is available from the factory. The length of steam hose after the "Y" connector must be the same for equal distribution of steam. (See Fig. 8)
- Mount the unit as close to the distribution pipe as possible. Use 1 1/2" Type L insulated copper pipe whenever the length of run exceeds 20 feet. Do not exceed a 30 foot run as the capacity of the unit will be decreased by as much as 15% and the increased static pressure could cause problems with the fill system.
- Maximum duct static pressure: 5" MDM units, 7" MDS and MDD units.
- Internal duct insulation should be removed in the "bulk evaporation" zone (Consult factory representative).
- Steam holes in the distribution pipe are located 2" from mounting plate and designed for a maximum duct wall thickness of 1". Consult factory if special hole locations are required.
- Do not mount the standard distribution pipe in a vertical downflow or vertical position in a horizontal flow system. Special pipes are available, consult the factory.

Steam Output													
Lb/hr	5	10	15	20	25	30	40	50	60	70	80	90	100
Kg/hr	2.3	4.5	6.8	9.1	11.4	13.6	18.2	22.7	27.2	31.8	36.3	40.9	45.4
Voltage	Electrode Current (amps)												
208/1	8.0A	16.0A	24.0A	32.0A	40.0A	48.0A	64.0A						
240/1	6.9A	13.9A	20.8A	27.8A	34.7A	41.6A	55.5A	69.4A					
277/1	6.0A	12.0A	18.0A	24.0A	30.1A	36.1A	48.1A	60.1A					
208/3	4.6A	9.2A	13.9A	18.5A	23.1A	27.7A	37.0A	46.2A	55.5A	64.7A	73.9A	83.2A	92.4A
240/3	4.0A	8.0A	12.0A	16.0A	20.0A	24.0A	32.0A	40.1A	48.1A	56.1A	64.1A	72.1A	80.1A
380/3	2.5A	5.1A	7.6A	10.1A	12.6A	15.2A	20.2A	25.3A	30.4A	35.4A	40.5A	45.5A	50.6A
440/3	2.2A	4.4A	6.6A	8.7A	10.9A	13.1A	17.5A	21.8A	26.2A	30.6A	35.0A	39.3A	43.7A
460/3	2.1A	4.2A	6.3A	8.4A	10.4A	12.5A	16.7A	20.9A	25.1A	29.3A	33.4A	37.6A	41.8A
480/3	2.0A	4.0A	6.0A	8.0A	10.0A	12.0A	16.0A	20.0A	24.0A	28.0A	32.0A	36.0A	40.1A
575/3	1.7A	3.3A	5.0A	6.7A	8.4A	10.0A	13.4A	16.7A	20.1A	23.4A	26.7A	30.1A	33.4A
600/3	1.6A	3.2A	4.8A	6.4A	8.0A	9.6A	12.8A	16.0A	19.2A	22.4A	25.6A	28.8A	32.0A

KW = .333 X Lbs/Hr

Amps(1Ph) = KW X 1000 / (Voltage)

Amps(3Ph) = KW X 1000 / (Voltage X 1.732)

Min. Circuit Ampacity = 1.25 X Rated Electrode Current (Note: with RDU add .5 Amps @ 208/240 Volts or add .25 Amps @ 480 Volts)

Minimum Circuit Ampacity determines wire size (AWG)

Steam Distribution for Ducted Systems

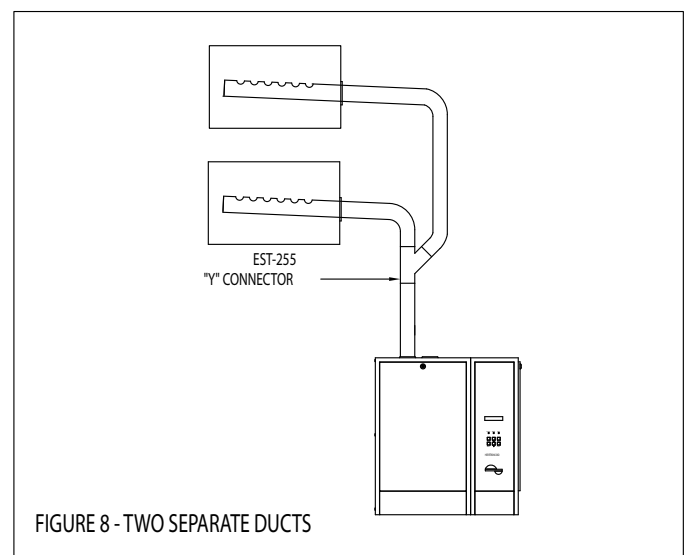
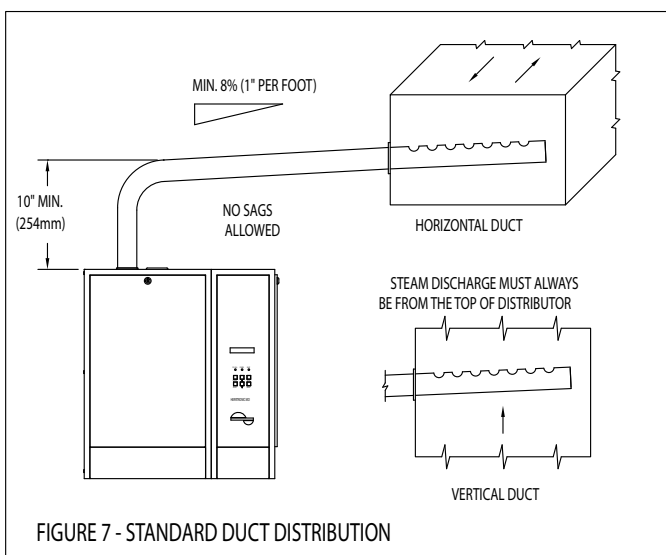
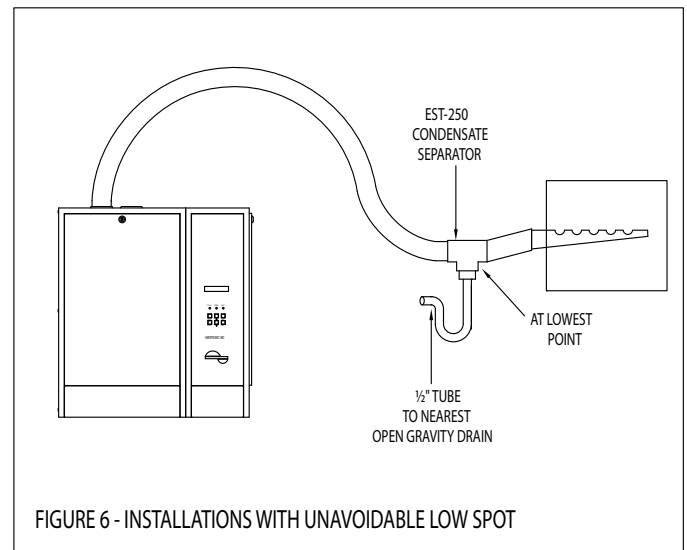
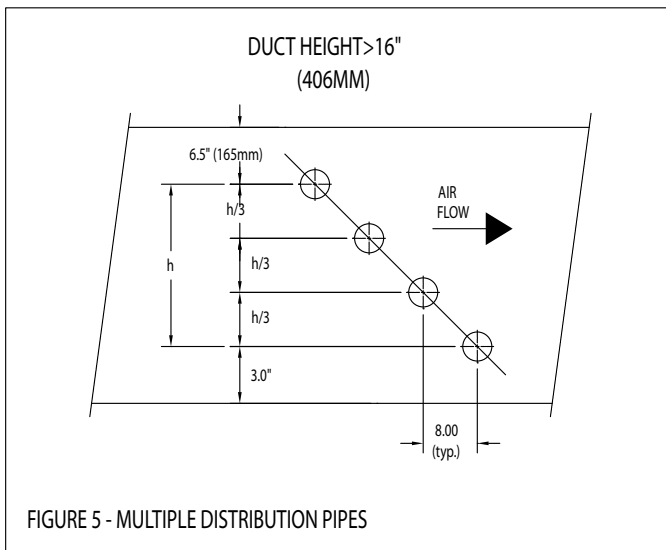
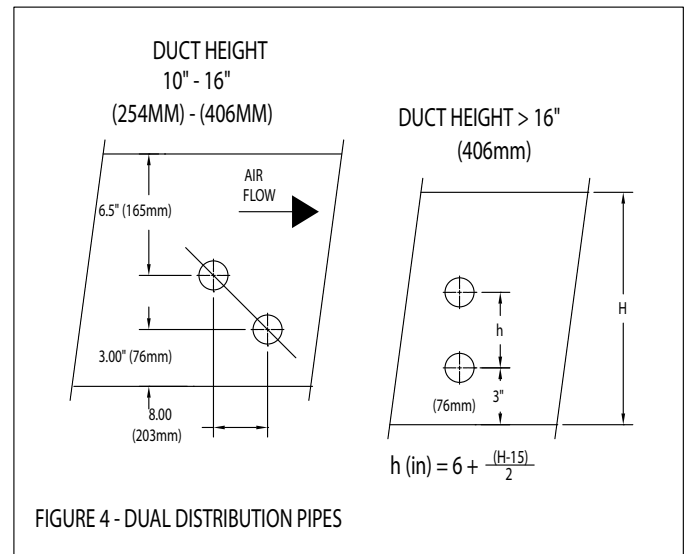
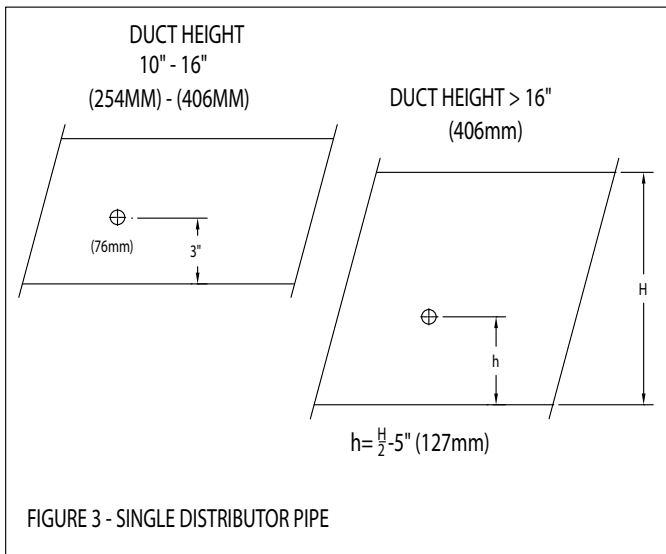

Controls

The Herrtronic MD Series Humidifier has the capability to utilize one of three types of control schemes.

1. On/Off
2. Proportional
3. Proportional + Integral

Controls may be supplied by the factory or others. The following information applies to all controls factory supplied or furnished by others. All external electrical control circuits are to be connected to the unit using the twelve pole terminal strip located in the electrical compartment. The terminal strip is accessed through the side electrical compartment door. Field wiring from humidistat to humidifier and between safety devices, such as high limit humidistat and air proving switches, should be 18 AWG stranded or 20 AWG solid wire. If conduit is not used with the controls wiring, install the black plastic fingered bushing (in accessory pack) and completely seal with RTV silicone.

Wall devices should be mounted at a height similar to that of a typical thermostat and should be located in an area that will provide good representation of the overall space being humidified. Do not mount wall devices directly in the air stream of a supply grille or room distribution unit.

Duct control devices should be mounted in a location where the humidity and temperature are uniform, usually the return duct. Do not mount in front of the steam distributor or in a mixing, turbulent, or isolated area.

Duct high limit devices should be mounted downstream of the steam distributors-far enough that under normal conditions in the air stream, the steam has been completely absorbed, typically 10 ft. The device should be located such that it can sense humidified air as it approaches saturation. Do not mount in dead air spaces such as inside of corners or erroneous operation may result.

Air proving devices should be mounted so that they sense air flow (or the absence of it). Wire the device so that it closes when air flow is present and will open when there is no air flow. The purpose of the device is to prove that air flow is present before steam is distributed into the duct.

The following information and diagrams are shown for each control scheme. Please refer to the control scheme that your humidifier was set up for and follow the diagram for control circuit connections. The factory-set control type and signal are indicated on a label adjacent to the controls terminal strip.

Control Circuit Connections

Mode 1 - ON/OFF Operation

1. Control Input - Unit will operate with any two position device (See Fig. 9). Demand for humidity will close the contact.
2. Limit Input - Unit will operate with any two position device (See Fig. 9). The humidistat contact will open on humidity rise.

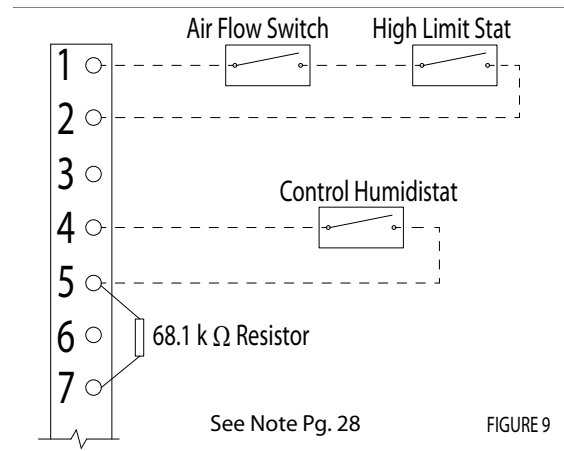

Mode 2 - Proportional Operation

1. If two position airflow and/or high-limit humidistat is used wire as shown in Figure 9.
2. Control Input - Interpreted by the humidifier as a demand of output signal. Input device should be linear. Unit can accept any VDC or mADC signal within a range of 0-20 VDC or mADC (See Fig. 10). Unit may also accept a resistive signal 0-135 ohms (See Fig. 11).
3. Limit Input - Unit may accept any modulating input within the same ranges as the control inputs listed above.
 - a. Proportional VDC or mADC (See Fig. 12)
 - b. Resistive (See Fig. 13)
 - Additionally, a P + I sensor may be used as a limit input.
 - c. VDC (See Fig. 16)
 - d. mADC (See Fig. 17)

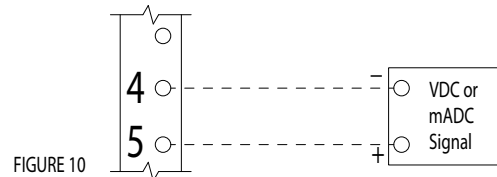

FIGURE 10

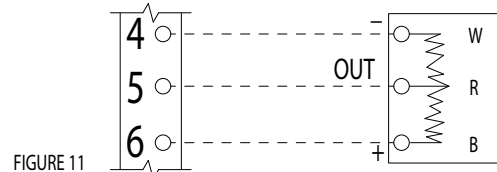

FIGURE 11

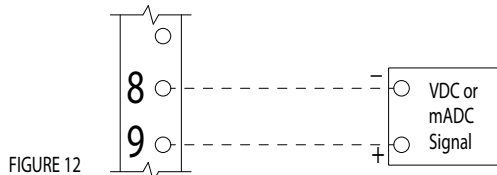

FIGURE 12

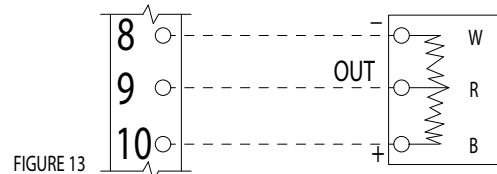

FIGURE 13

Mode 3. (Proportional + Integral)

1. If two position airflow and/or high-limit humidistat is used, wire as shown in Figure 9, page 10.
2. Control Input - Unit will accept any sensor input that provides a VDC (See Fig. 14A, wall or Fig. 14B, duct) or mADC (See Fig. 15) signal within a range of 0-20 VDC or mADC that is proportional to the humidity level in the air. The sensor may be direct or indirect acting but must not have an impedance greater than 500 ohms, and should be linear. Example - A direct acting 2 - 10 VDC wall sensor will send a 2 VDC signal if the R.H. level in the space is 10%; it would send a 10 VDC signal if the R.H. level is 90%. The humidifier receives this input and compares it to the control setpoint that has been programmed into the unit. The microprocessor modulates the output capacity of steam. The adjustable integration period will review performance over the given time and will make tuning adjustments by shifting the proportional bandwidth to correct for over or under humidification offsets automatically.
3. Limit Input - Unit can accept any sensor input as specified above.
 - a. VDC sensor input (See Fig. 16).
 - b. mADC sensor input (See Fig. 17).

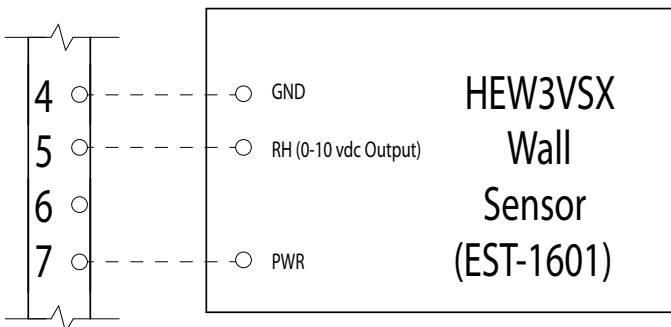

FIGURE 14A

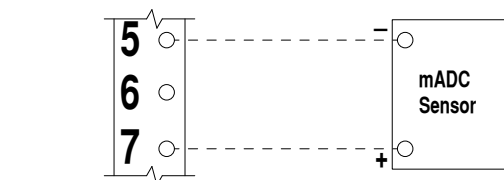
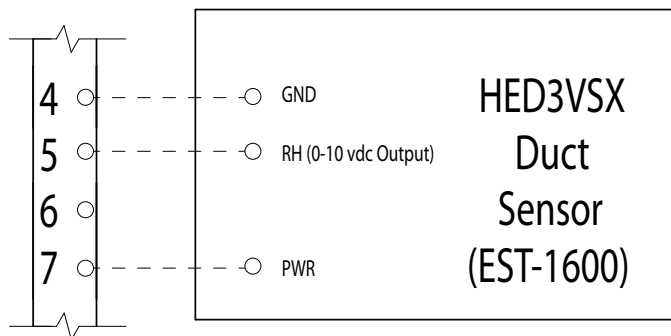

FIGURE 15

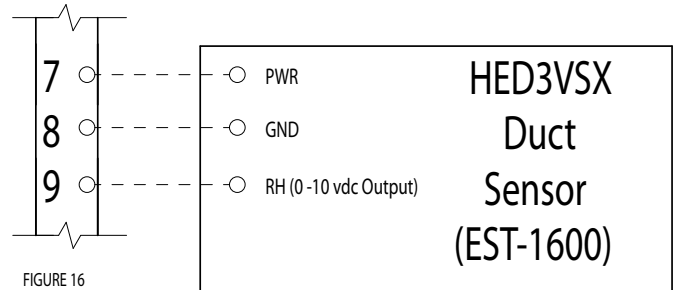

FIGURE 16

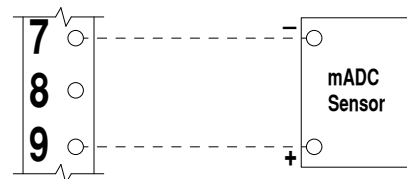

FIGURE 17

External Off Switch

Should a field installed remote off switch be required, follow the wiring diagram below (See Fig. 18). Be sure to remove the jumper wire between poles 1 and 3 on "Controls Terminal Strip." The remote off switch is to be wired between poles 1 and 3. This switch will override the unit on/off switch to turn the unit off only, it will not restart the unit. The unit must be turn back on by the unit on/off switch.

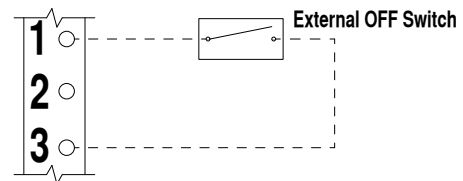

FIGURE 18

Remote Alarm

The Herrtronic MD Humidifier is equipped with a remote alarm output. It is a triac output that may be used to energize an external relay or buzzer to indicate an alarm condition is present. The alarm output is activated whenever an indicating fault condition exists. When units are networked together, the master's alarm contacts will close if a fault occurs at either the master or one of the slave units. The contacts are connected at poles 1 and 2 of the remote alarm terminal strip 3.

In order to use the remote alarm output with a Building Management System, the remote alarm output must be used to energize a mechanical relay. The contacts of the external relay may then be wired to an input on the BMS to indicate if an alarm condition is present. The remote alarm output may not be used like a dry contact to a BMS.

Do not exceed the contact specifications!

Contact rating:

- 24 VAC - 3.0 A
- 24 VDC - 2.1 A

Unit Networking

When networking units together in a master/slave configuration, be sure to maintain polarity between poles 11 and 12 on all units. Units are to be wired as a parallel circuit. More than one branch is allowable so that the master unit can be centrally located (See Fig. 19). A maximum of 29 slave PC boards (29 MDS or MDM units or 14 MDD units) may be configured as a network. Included in each installation pack is a 120 ohm resistor. This resistor should be inserted into R28 on the microprocessor board (see Fig. 32) on the appropriate end units of the chain. (Refer to Fig. 19)

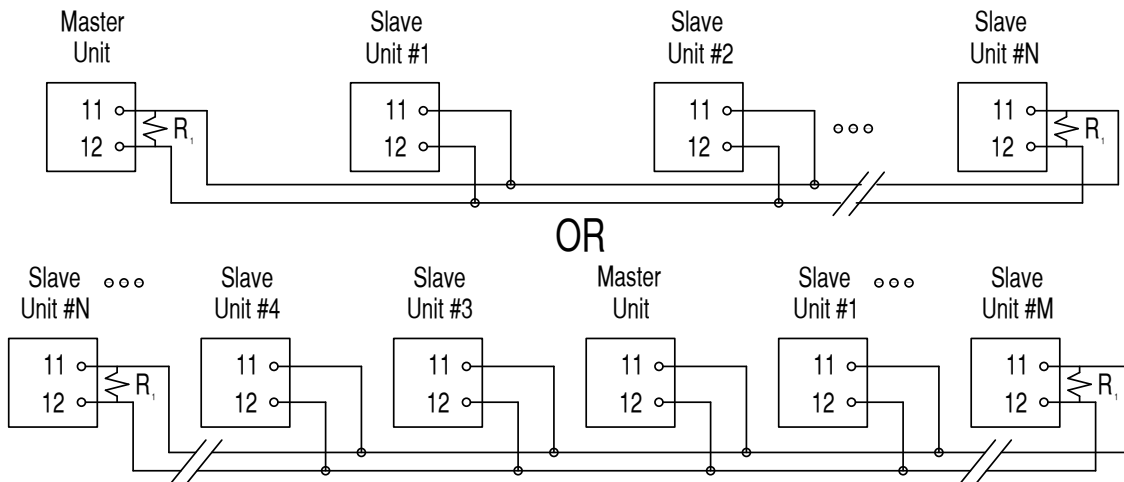

FIGURE 19

Installation, Operation, & Maintenance Manual

IV. OPERATING INSTRUCTIONS

Your unit has been pre-set for 1 of 3 control modes:

1. On/Off
2. Proportional
3. Proportional and Integral

With each control mode, there is a specific set of operating parameters and setpoints that apply. All of the setpoints have been preset at the factory to simplify the start-up procedure. The following table identifies the parameters, setpoints and preset values that apply to each mode. Below the table is a more detailed description of the setpoint parameters. All setpoints have pre-set default values to simplify programming. Instructions for adjustment follow.

Setpoint Parameters	Control Mode			Menu to Adjust	Adjust Setpoint Range	MDM Preset Values	MDS/MDD Preset Values
	1	2	3				
Control Setpoint			X	2	20-98%	35%	35%
Limit Setpoint (Note 3)		X	X	2	20-99%	75%	75%
High Humidity Alarm			X	2	20-100%	99%	99%
Low Humidity Alarm			X	2	10-98%	10%	10%
Capacity Setpoint	X	X	X	2	10-100%	100%	100%
Auto Drain	X	X	X	2	0-99 Days	7 Days	7 Days
Low Drain Threshold	X	X	X	2	50-100%	85%	80%
Steam Output Rating	X	X	X	3	0-999 lbs/hr.	5-30 lbs/hr.	10-100 lbs/hr.
Electrode Current Rating	X	X	X	3	0-999 Amps	As required	As required
High Drain Threshold	X	X	X	3	100-120%	110%	110%
Cycle Time	X	X	X	3	30-300 Sec.	75 /(90) See note 1	130 /(150) See note 2
Proportioning Band			X	3	+/- 2 to 15%	+/- 10%	+/- 10%
Integration Period			X	3	0-60 Min.	30 Min.	30 Min.
Throttling Range (Note 3)		X	X	3	0-25%	10%	10%
Unit Address	X	X	X	3	0-99	01	01 MDS (00, 01 MDD)
Low Drain Limit	X	X	X	3	25-75%	50%	50%
Manual Drain	X	X	X	5	Active/Inactive	Active	Active
Leakage Protection	X	X	X	5	On/Off	Off	Off
End of Cyl. Life Setpoint	X	X	X	5	1-500 hrs.	6 hrs.	6hrs.
Electrode Run Time	X	X	X	5	0-999,999 hrs.	0	0
Limit Input (Note 3)		X	X	5	Enable / Disable	Enable	Enable
Control Input	X	X	X	5	Enable / Disable	Enable	Enable
Drain Tempering	X	X	X	5	Active/Inactive	Inactive	Inactive

Notes:

1. On units where voltage is 380 VAC or greater, the cycle time is 75 seconds. On units where voltage is 240 VAC or less, the cycle time is 90 seconds.
2. On units where voltage is 380 VAC or greater, the cycle time is 130 seconds. On units where voltage is 240 VAC or less, the cycle time is 150 seconds.
3. If a unit is ordered with the modulating high limit, the Limit Input will be ENABLED. If an "On/Off" type or no high limit is used, the Limit Input and Throttling Range screens will have been eliminated.

Parameter Definitions: All Control Modes

- Output Rating - Unit design capacity (lbs/hr).
- Electrode Rating - Current rating that corresponds to unit design capacity.
- Capacity Rating - Output capacity as a % of the output rating.
- Low Drain Threshold - Minimum output capacity % that initiates a drain cycle.
- High Drain Threshold - Maximum output capacity % that initiates a drain cycle.
- Auto Drain - Time in days between system shutdown and cylinder drain.
- Manual Drain - Operator activated cylinder drain
- Drain Tempering - Allows mixing of cool inlet water with drain water for tempering
- Cycle Time - Time in seconds between fill cycles.
- Unit Address -In network installation; "master unit" is "00", slaves "01" to "99".
- Leakage Protection - Electrically disconnect electrodes during drain cycle.
- Electrode Run Time - Hours of cylinder operation.
- Control Input - Space condition humidity input device.
- End of CYL Life Setpoint - Unit has not achieved desired output within specified time.

Specific Control Modes (See Chart)

- Control Setpoint - Desired % RH
- Limit Input - Modulating high limit from a controller or sensor
- Limit Setpoint - Maximum allowable % RH limit
- Low Humidity Alarm - Indication of control humidity level below alarm setpoint.
- High Humidity Alarm - Indication of control humidity level exceeding alarm setpoint.
- Proportioning Band - Humidity span around control setpoint where modulation occurs.
- Integration Period - Length of time period for %RH evaluation and adjustment.
- Throttling Range - Humidity range below limit setpoint where modulation occurs.

All setpoints have pre-set default values to simplify programming -Instructions for adjustment follow.

Programming

When power is initially applied (i.e. close the disconnect), the liquid crystal display (LCD) will become active (without user action). A "signature" screen will appear:

HERRMIDIFIER INC.
HERR 002 VER 5.X

"Ver 5.X" denotes the program level of the microprocessor. The specific "Ver 5.X" level should be included in any inquiry to a TRION/HERRMIDIFIER representative or the factory. After a brief pause, the "Main Menu" will appear:

SYSTEM OFF 000% X 01
MENU 1

The contents of the display provide the following information:

"System Off" - The "ON/OFF" button is in the "OFF" position.
 "000%" - Output capacity in % "0%" = 0 lbs /hr. Range is 0-100%

"X" - Control Mode:

1. On/Off
2. Proportional
3. Proportional + Integral

"01" - Unit Address

"Menu Y"- Designates program MENU:

- Menu 1 - Status Items (non-adjustable)
- Menu 2 - Setpoint Adjust (non-secured)
- Menu 3 - Setpoint Adjust (secured by "password")
- Menu 4 - Network Communication
- Menu 5 - Maintenance Adjust (infrequently used options)

Prior to start-up, the operator should review and/or adjust all setpoints and, if needed, establish the network configuration.

Programming is accomplished as follows:

1. Press the "up" arrow for Menu 2. The LCD screen will read:

SYSTEM OFF 000% 3 01
MENU 2

NOTE!

Control Mode may be: (1), (2), or (3). This example pertains to mode (3). In control modes (1) and (2), not all setpoints will appear (The table on page 13 identifies parameters visible in each mode).

2. Press "Enter" to initiate the Menu program. The LCD will read:

CONTROL 3 01
SETPOINT 35%

3. Press the "up" or "down" arrow button to increase or decrease the pre-programmed setting as desired.
4. Press "Enter" to register the setpoint and move to the next setpoint.
5. Repeat steps "3" and "4" until all of that Menu's setpoints are registered.
6. Press "Back" to return to the MAIN MENU. (Menu 1)
7. Press the "up" arrow for Menu 3. The LCD will read:

SYSTEM OFF 000% 3 01
MENU 3

8. Press "Enter". The LCD will read:

ENTER PASSWORD

NOTE!

Menu 3 is password secured. The setpoints in this menu are protected from routine adjustment. The unit is shipped new with three presses of the "Enter" key as the password.

9. To set a new password, six keystrokes are required. The first three keystrokes tell the unit that a new password is being set. The last three keystrokes are the actual password. To set a new password, press "On/Off", "up" arrow, "Enter" and any (3) additional keystrokes - i.e. "up" arrow, "down" arrow, "Back". These last (3) keystrokes become your "password." Any subsequent revisions to Menu 3 setpoints will require use of this three keystroke "password."

NOTE!

If the wrong password is entered, the LCD will read:

INCORRECT
PASSWORD

Refer to step 9. The last (3) keystrokes become the new password.

10. After establishing the “password”, repeat steps 3 through 5 to program Menu 3. Press “Back” to return to MAIN MENU. (Menu 1)
11. Press “up” arrow for Menu 5. The LCD will read:

SYSTEM OFF 000% 3 01
MENU 5

12. Repeat steps 3 and 4 to complete Menu 5. The press “Back” to return to the MAIN MENU (Menu 1)

NOTE!

Programming of the setpoints for the unit is now complete. If there are multiple Herrtronic MD's networked together OR you are programming a MDD (110-250 lbs/hr.) unit, continue to step 13. Otherwise proceed to STARTUP with CHECK LIST, page 16.

Access Menu 4 for MDD Models only (2 tanks) or Networked Units. This allows you to program the slave circuit board.

NOTE!

The address in the below screen is now 00. This allows the ‘Master’ unit access to any ‘Slave’ in the ‘Network.’ Only one Master unit ‘00’ per Network can be used.

13. Press the “up” arrow for Menu 4. The LCD screen will read:

SYSTEM OFF 000% 3 00
MENU 4

14. Press “Enter”. The LCD will read:

POLLING SLAVE PRESS
BACK FOR MASTER MENU

This screen will appear only when power has been initially applied or reapplied. Wait about (5) minutes to allow the microprocessor to “Poll” the network.

15. After returning to the screen described in step 13, press “Enter”. The LCD will read:

ENTER SLAVE
NUMBER 01

16. Press “up arrow” if you would like to access slave 2 and “up arrow” again for slave 3, etc.
17. From the screen described in step 15, press “Enter” to access Slave 01. The LCD will read:

SYSTEM OFF 000% 2 01
MENU 1

NOTE!

On MDD units, the address of the slave unit is factory set as 01. To reprogram the Slave, repeat steps 1 through 12 described on previous page.

NOTE!

If communications are not successful, the LCD will read:

NO REPLY ENTER TRY
AGAIN BACK TO EXIT

Possible sources for failed communication attempt:

- A. Chosen Slave does not exist.
- B. Slave unit does not have power connected.
- C. Faulty communications wiring
 1. Improper polarity of RS-485 (Controls Terminal Strip Poles 11 & 12).
 2. Resistor required to signify the beginning and end of the “Network” is not installed correctly. On individual MDD units, these resistors are not necessary. See “Installation/Networking” section for clarification.
- D. It is possible for high levels of Electro-Magnetic Interference (EMI) to impede communications between units. Press “Enter” to try communications again, or “Back” to return to “Master” units’ Main Menu.

18. To return to “Master” unit (unit address 00) press the “up” arrow (3) times. The LCD will read:

SYSTEM OFF 000% 2 01
MENU 4

19. Press “Enter”. The LCD will read:

LEAVING SLAVE PRESS
BACK FOR MASTER MENU

20. Press “Back” and return to “Master” unit (unit address 00) Main Menu.
21. To program additional slaves, repeat steps 13-20. Programming is complete. Proceed with START-UP section.

Start-up with Check List

After all programming is completed (and the total installation is complete), the Herrtronic MD system is ready to start. At the end of START-UP section is a CHECK-LIST. The CHECK-LIST is intended to highlight critical installation points. A poor installation frequently results in start-up difficulties, and always results in less than ideal operation of the humidifier.

IMPORTANT- Before any TRION/HERRMIDIFIER representative or the factory is contacted with a start-up problem; please have the checklist completed as far as possible.

1. Set all controls to their lowest setting (control and high limit if applicable). In systems using distributor pipes, make sure the fan is operating. By placing the controls at their lowest setting and turning the unit "ON" at the "ON/OFF" button, the unit should not try to initiate production of steam. On MDD units it is necessary to turn the Slave "on" through the communications, Menu 4.

Find the lowest setting in each Control Mode as follows:

- Mode 1 (On-Off)-Turn the dial to the OFF position or its lowest setting.
- Mode 2 (Proportional) - Set the controller to send the lowest signal in the range (i.e. 4 mA in a direct 4-20 mA range).
- Mode 3 (P + I) - Set "Control Setpoint" through Menu 2 at least 11% below the "Control RH" displayed in Menu 1.

2. Set high limit to its highest setting (all control modes).
3. Set CONTROL input to get the Herrtronic MD to attempt 100% of capacity as follows:
 - Mode 1 (On-Off) - An audible "click" will be heard when the humidistat is asking for full output.
 - Mode 2 (Proportional) - Set controller to send Herrtronic MD a full signal (i.e. 20 mA in a direct 4-20 mA output range).
 - Mode 3 (P + I) - Set "Control Setpoint" through Menu 2 20% Above "Control RH" displayed in Menu 1.

4. TURN UNIT "ON". (ON MDD UNITS, BOTH MASTER AND SLAVE BOARDS MUST BE TURNED "ON".) Slave units can be turned on via the Master board through communications or directly from the slave circuit board. Once the unit gets the signal to run and unit is turned "On", the contactor will pull in within 5 seconds, followed by the fill valve being energized. The unit will attempt to fill to FULL OUTPUT (100%) or CYLINDER FULL. If the unit fails to reach 75% of capacity on the initial fill (as shown by CYLINDER FULL light illuminated and <75% Output), you should use the jumper wires enclosed in the accessory envelope and arrange them as shown on the diagrams on Figure 28, page 21. Be sure to disconnect power first and re-tighten each of the electrode knobs.

NOTE!

THIS WILL NOT BE POSSIBLE ON UNITS WHICH ALREADY HAVE POWER TO EACH ELECTRODE OR ANY MDM. Before restarting the unit, drain half the water from the cylinder using "Manual Drain" found in Menu 5.

5. If low conductivity water is being supplied, as indicated by a low percentage of output (70% and under) and the CYLINDER FULL light is illuminated, you may want to artificially

increase the output. This is accomplished by the following procedure:

- Drain 1/2 the water from the tank using the manual drain option in Menu 5.
 - Add 1 Alka-Seltzer tablet
 - Restart
 - Repeat if needed
6. Fill System (Fig. 20) Check Points
 - No leaks in system
 - Virtually all the water entering the FILL TEE should be going down the FILL TUBE as opposed to the OVERFLOW TUBE. A slight adjustment may be needed to the Metering Screw (Fig. 21) if water supply pressure is too high. Turn the screw clockwise to close, or counter clockwise to open.

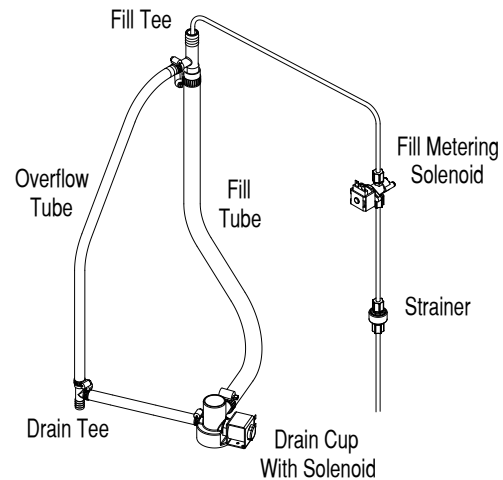

FILL SYSTEM

Figure 20

7. If you need to "TEMPER" the drain water because of local codes or low temperature drain piping is used, activate "DRAIN TEMPERING" (Menu 5)

NOTE!

The drain water is TEMPERED or COOLED by the addition of fresh water while the drain solenoid is open. The proper rate of fresh water will cool the drain water and still allow the humidifier to drain freely. Use the fill valve adjusting screw (Fig. 21) to regulate the flowrate of the cool inlet water. The amount of tempering will depend on incoming temperature and pressure of the water supply.

8. Once the water is boiling and steam is being produced, check the following:
 - No leaks in the steam distribution lines or connections.
 - The steam has a clear path from the cylinder to its distribution points. Any low spots in the steam distribution line must be trapped. (See Fig. 6)
9. Unit needs to drain hot water to check proper drain line installation. Unit may be draining through normal operation, but if not, initiate a drain through the MANUAL DRAIN in

Menu 5. Once hot water is being drained, check the following:

- Steam condensing on the bottom of the cabinet. Correct by lowering the drain line or adding DRAIN TEMPERING.
- Flash steam entering the steam cylinder compartment due to inadequate drain line.
- Flash steam entering the electrical compartment if the knockout for the control wires isn't sealed. This should be sealed even if there doesn't appear to be any steam entering into the compartment. If conduit is not used with the controls wiring, install black plastic fingered bushing and completely seal with RTV Silicone.
- Water must drain from unit freely. If there are restrictions in the drain line, it will send hot water/steam up into the CABINET DRAIN and/or the OVERFLOW TUBE which will pool inside the cabinet and could leak out of the unit onto the floor.

START-UP IS COMPLETED. MAKE SURE CONTROLLING DEVICES ARE SET FOR DESIGNED CONDITIONS. PROCEED TO AND COMPLETE CHECK-LIST. AFTER INITIAL WARM UP, SHUT UNIT DOWN, TURN OFF MAIN POWER AND RECHECK TIGHTNESS OF POWER CONNECTIONS WHILE UNIT IS WARM (TORQUE TO 15-20 in-lbs.).

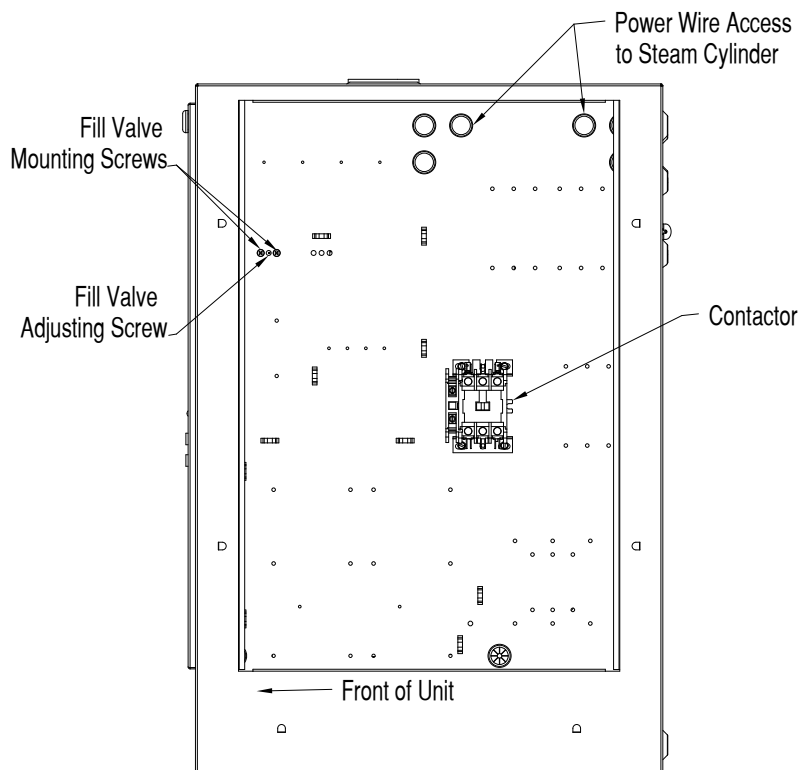

View in from Electrical Access Door
METERING SCREW

Figure 21

PRE-STARTUP CHECKLIST

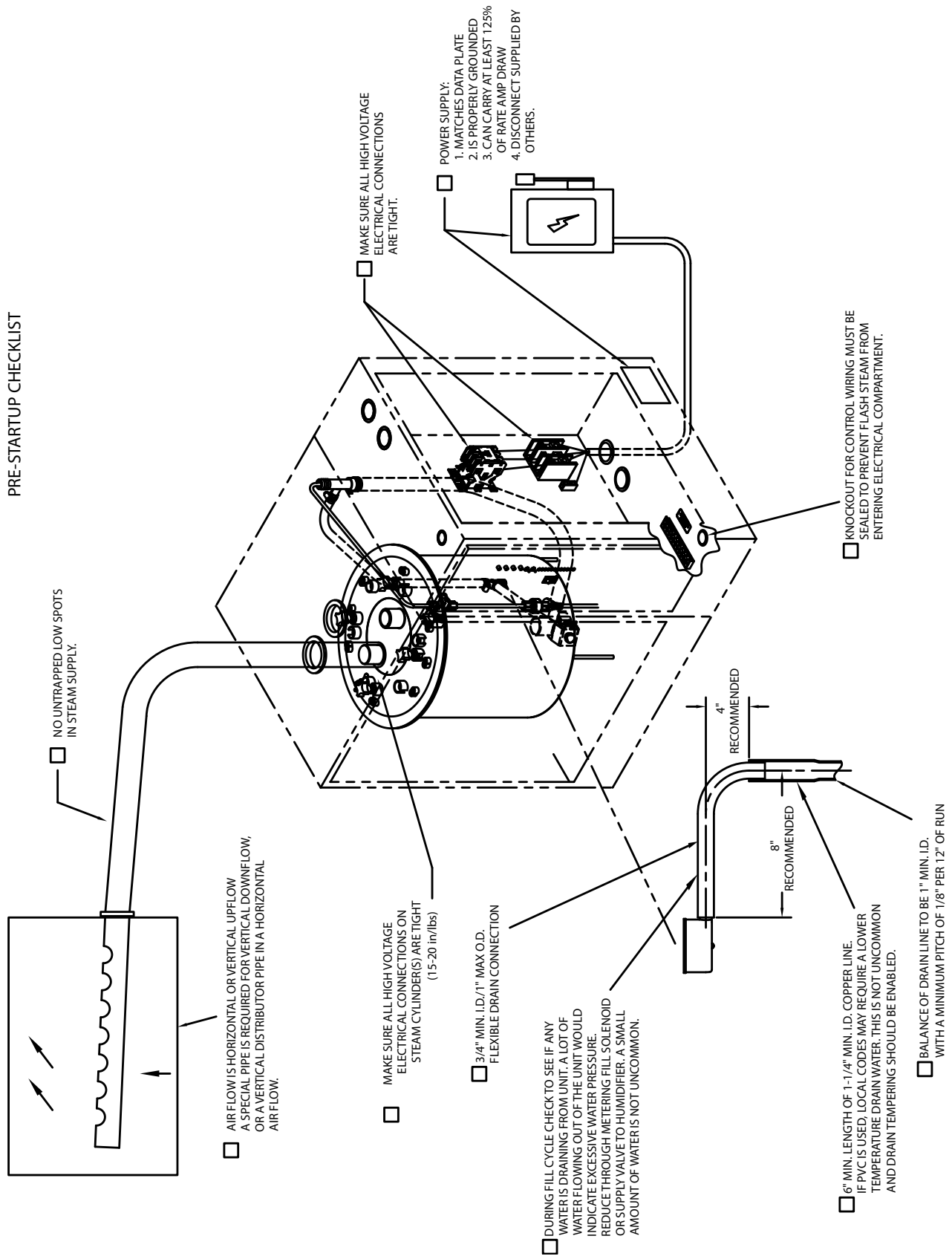

Diagnosics

The Herrtronic MD humidifier includes built-in diagnostics capability to identify potential problems, protect the system, and minimize service/repair time. Should the system detect a critical condition, a "fault" warning will be displayed on the LCD. Certain faults prompt immediate system shutdown to protect the MD unit or ductwork. Other faults allow the unit to continue to operate but alert the operator to potential problems that require maintenance. Other faults, which are designed for initial system tune-up or preventative maintenance, are classified as "non-indicating." These faults are viewed by pressing the "fault" key on the control panel. The table reflects all of the faults the system is capable of detecting. Please note, however, that certain faults are unique to certain control modes or networked systems and are only visible where applicable.

During operation, when an "indicating" fault occurs, the word **FAULT** will be visible in the lower right hand section of the LCD. The red fault light will also be illuminated.

If an "indicating" fault has been detected or a preventative check is being performed, follow this procedure to determine the cause of the fault:

1. The LCD must be in the MAIN MENU to access diagnostics. Press "FAULT" key to determine the type of fault.
2. Press the up arrow to determine if there is more than one fault.
3. If possible, correct the condition causing the fault signal or plan corrective action.
4. Press "ENTER" to clear the fault signal from the display. When "ENTER" is pressed, all faults registered in the unit will be cleared. If the condition causing the fault is not corrected, another fault signal will occur.
5. Under normal operating conditions, pressing the "FAULT" button will prompt the following display:

**NO FAULTS PRESENT
IN SYSTEM**

In a multi-unit network, the master ("00") unit will indicate a fault within the entire network. To find the fault(s), follow steps 1 and 2 for the master unit. If the display indicates "No Faults Present In System," then neither the Master, nor any Slave unit, has any faults.

If any slave has a fault, the LCD will read:

SLAVE XX HAS FAULTS

Utilize the communications (Menu 4) from the Master to access the particular slave with fault(s) to determine the fault. (Refer to communication instructions in the programming section). Press the "up" arrow button to determine if there is more than one "slave" that has a "fault."

System Fault Conditions

(See Troubleshooting Section for corrective action)

Fault	Operation Status	Comments
Current Overload (4)	Shutdown and Drain Manual Reset(1)	138% of Capacity Setpoint Exceeded
Contactor Failed (4)	Continued Operation	Humidification Required
Cylinder Full Zero Current	Continued Operation	Humidification required; unit not functioning properly
Fill System Fault (4)	Shutdown and Drain Manual Reset (1)	Fill for 15 min. – cannot achieve capacity setpoint or cyl. Full
Zero Electrode Current	Continued Operation	Humidification required, no current draw
Non-zero Slowly Decreasing Amps	Continued Operation	Defective drain system
Non-zero Non-Decreasing Amps	Continued Operation	Defective drain system
Non-zero Non-Increasing Amps	Continued Operation	Defective fill system
Non-zero Slowly Increasing Amps	Continued Operation	Defective fill system
Cylinder Full	Continued Operation	Caused by low water conductivity, foaming, or end of cyl. Life.
End of Cylinder Life (4)	Continued Operation	Cannot achieve capacity and on cylinder full or programmed duration
Air Flow / High Limit	System Shutdown, Automatic Reset (2)	Insufficient airflow / high limit setting exceeded
Hi Humidity Alarm (3)(4)	Continued Operation	Alarm threshold achieved
Lo Humidity Alarm (3)(4)	Continued Operation	Alarm threshold achieved
Humidity Sensor Failed (3)	Continued Operation unless both fail	Humidity less than 4% or greater than 100%
Slave "XX" Has Fault (4)	Continued Operation of Master	Slave has fault
Communication Port Fault	Continued Operation of Master	Slave operation unknown

1. Manual reset requires the problem be corrected and the unit turned "on" at the keypad
2. Automatic reset will resume normal operation once the circuit is closed.
3. Proportional + Integral Control Only
4. Indicating Fault

Maintenance

To maintain efficiency of the unit, the water level in the cylinder will slowly rise as the electrodes become coated with minerals. Progressively, the water level reaches the cylinder full electrode, representing the maximum allowable water level. Eventually, all of the usable electrode surfaces will be coated. After the end of cylinder life setpoint has been reached, the LCD will read "End of Cylinder Life" fault. Cylinder replacement should occur to maintain satisfactory humidity levels. "End of Cylinder Life" varies with water conductivity. Refer to the chart that follows:

Conductivity (micro-mhos) (approximately)	Average Cylinder Life (Hours)
70	2000
100	2000
135	1900
170	1800
250	1300
500	800
750	650
1000	500

NOTE

Many factors in addition to water conductivity effect cylinder life. Total dissolved solids (TDS) and exact mineral content of the water can have negative effects on cylinder life. Your representative will be happy to review your water analysis. If you don't have an analysis and are on a municipal system, the municipal water authority will provide one free of charge. Conductivity between 70 and 200 micromho is best handled with "on/off" control. Discuss your application with the factory if your water is in this range and "Proportional" or "Proportional + Integral" control is required. Water with less than 70 micromho may not be sufficient to allow the unit to operate. TRION/HERRMIDIFIER has considerable experience optimizing the performance of your humidifier on "fringe" water conditions. Consult your representative.

To Remove the Cylinder:

1. Turn the unit "off" by pressing the "on/off" button. Drain the cylinder completely using the manual drain (Menu 5).
2. Disconnect the power to the unit..
3. Disconnect the electrode power wires (and jumpers if used) - noting the orientation, and the cylinder full electrode wire from the cylinder. Remove the expired cylinder from the cabinet.
4. Position the new cylinder in the cabinet. Place the new "O" ring as shown in Fig. 22. Lubricate the "O" ring with water only and install cylinder into drain cup, EST-1062, pushing down firmly with a twisting motion.
5. Reconnect the power wiring (and jumpers if required) referring to appropriate Figure on the next page that matches the power wiring configuration of the unit. Be certain to use lock washers on each electrode and tighten the electrode knob (Fig. 25 or 29).
6. Installation is now complete, Reconnect power, turn unit

on, allow cylinder to fill and check for leaks. AFTER INITIAL WARM UP, SHUT UNIT DOWN, TURN OFF MAIN POWER AND RECHECK TIGHTNESS OF POWER CONNECTIONS WHILE UNIT IS WARM (TORQUE TO 15-20 in-lbs.).

Extended Shutdown:

The humidifier is set by the factory to drain if the unit doesn't operate for seven days. However, the drain time can be revised through reprogramming (Refer to Page 14). Always drain the cylinder completely if it will be off of an extended period of time (see Auto drain feature, menu 2, page 13).

FIGURE 22

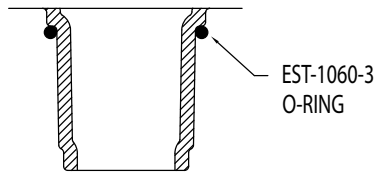

FIGURE 23

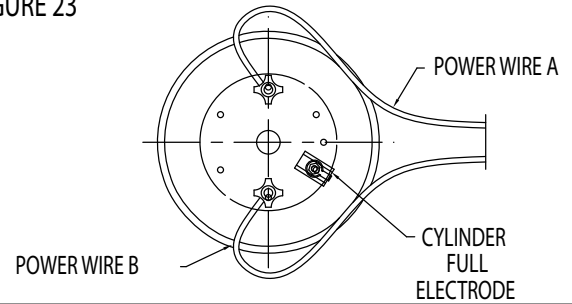

FIGURE 24

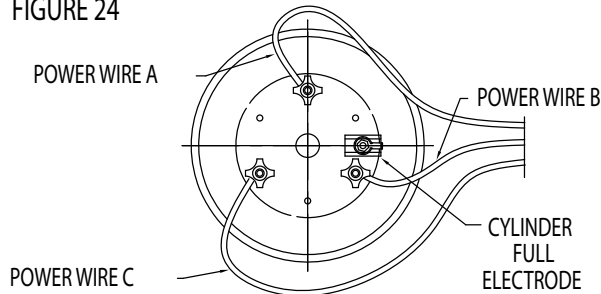

FIGURE 25

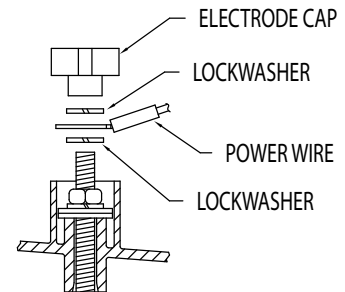

FIGURE 26

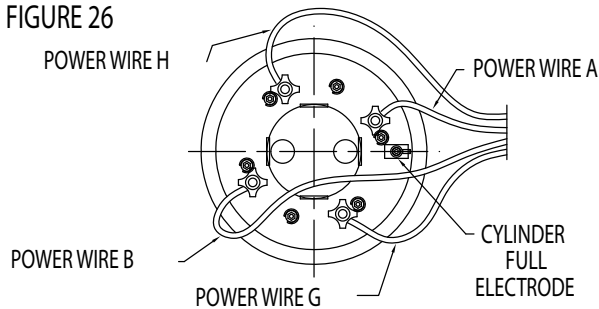

FIGURE 27

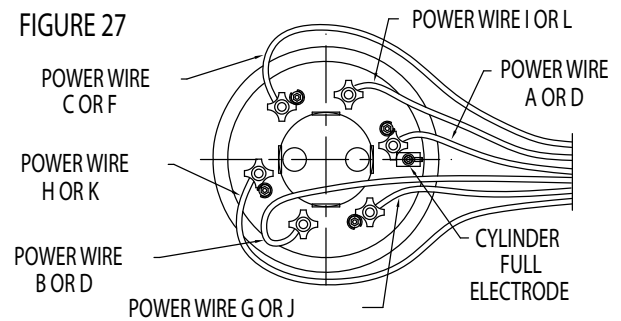

FIGURE 28

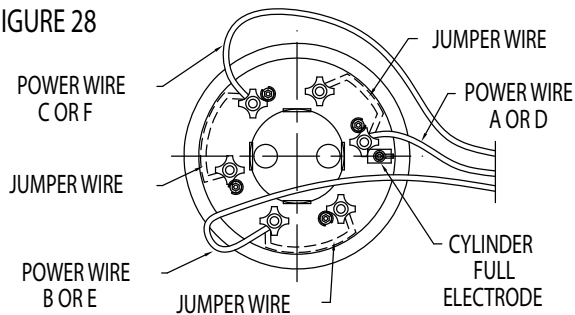

FIGURE 29

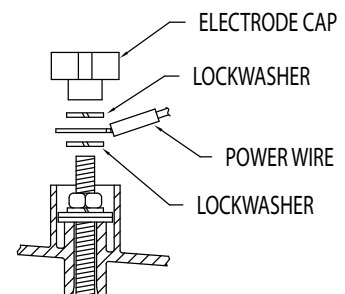
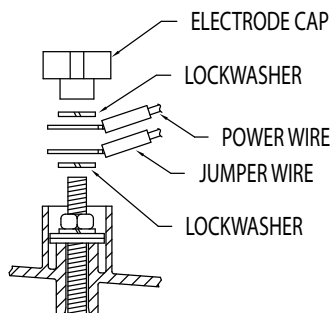

FIGURE 30



V. TROUBLESHOOTING GUIDE

General Maintenance Notes

WARNING!

High Voltage components are present in both the cylinder and electrical compartments. Maintenance must be performed by qualified individuals. Absolutely no other components may be mounted inside or electrically tapped into humidifier without voiding the warranty.

- A. Externally, controls of many configurations may be used with your new MD series humidifier. TRION/HERRMIDIFIER strongly recommends the use of some type of control humidistat, a high limit humidistat, and an air proving switch to insure proper operation of your humidification system.
- B. Electrode boilers operate by passing current through the water utilizing the conductivity of the water itself as a current path. The flow of current through the water generates heat which boils the water and produces the steam required for humidification. The diagnostic features of the MD series humidifier are designed to help you maintain and optimize your system for years of service. If the fault light is illuminated, see the diagnostic section on page 19.
- C. The wiring diagram, illustrated on page 34 (for MDD units, the wiring diagram is located on pages 11 and 12 of the "MDD Supplement"), clearly shows the path of the 24 VAC control circuit. Control voltage leaves the transformer, passes through a fuse and then into the circuit board. The microprocessor has inputs and outputs for the humidistats or sensors, contactor auxiliary pole, differential pressure switch and the control loop. Power for the control loop goes through the external off switch (optional), the door interlock switch, and then back to the microprocessor. Understanding the wiring diagram will give you a better idea of the logic of the MD series humidifier and simplify your troubleshooting.
- D. If any changes to the physical board set-up are made, i.e. capacity changes or resistor, the unit must be reset. You may reset the unit by depressing the "reset" button on the back of the board or turning the unit off and on through the disconnect (See PC Board diagram on page 28).
- E. If the circuit board needs to be changed, make sure the ribbon cable connector from the main board to the display board is as originally supplied (red stripe on top at LCD and on the right at PCB). Reattach the (three) 11 Pin connectors in the same manner. (J1, J3 and J5)

Operating The Humidifier Without External Controls

The humidifier has the capability to operate without any external signals being sent to the unit. Being able to isolate the humidifier from the external controls is invaluable in troubleshooting. The unit can be "jumped-out" whether it's mode 1, 2, 3.

- A. Mode 1 - On/Off
 1. Remove any control wiring supplied by others; mark wires for re-attachment.
 2. Jump terminals 1 & 2 on controls terminal strip.
 3. Jump terminals 1 & 3 on controls terminal strip
 4. Jump terminals 4 & 5 on controls terminal strip.
 5. After unit is turned ON, it should fill to 100% output (or

capacity setpoint) or cylinder full.

6. After confirming proper operation, reattach controls for normal operation and remove added jumpers.

B. Mode 2 - Proportional

This signal is typically supplied by others. The MD has 2 separate VDC power supplies accessible from the controls terminal strip (as shown on page 26). Either one of these outputs will be sufficient to bring the MD into an operational state. You will need to know the control signal being supplied and select the 5 VDC or 20 VDC output from the control terminal strip. The humidifier will react in proportion to its programmed signal range.

Example: The humidifier is set up for 0-10 VDC signal from the BMS. The humidifier is being jumped-out with the 5 VDC signal from pole 6 to pole 5 on the control terminal strip. You can expect the humidifier to fill to 50% output or cylinder full.

1. Remove any field installed control wires; mark for re-attachment.
2. Through Menu 5, disable limit input (if applicable).
3. Jump terminals 1 & 2 on controls terminal strip.
4. Jump terminals 1 & 3 on controls terminal strip.
5. Select 5 VDC from control terminal strip pole 6 or 20 VDC from control terminal strip pole 7 to jump to pole 5 on the controls terminal strip.
6. If signal provided is other than VDC, use the following comparisons: mADC; 20mA = 20 VDC, resistance; 135 ohms = 2 VDC

C. Mode 3 - Proportional + Integral

If a problem is detected in the sensors, the diagnostics will pick up the problem and display a fault with the sensor. To jump-out, follow the steps 1-4 listed for Mode 2 above, then follow steps 1 through 3 below.

1. If the control signal is a DC voltage type with a maximum signal level of 5 VDC or greater, or a DC millilamp type with a maximum signal level of 20 mA or greater, apply a jumper wire between poles 5 & 6 on the controls terminal strip.
2. A control RH level will be indicated based on the jumped input signal and the factory board set up for the actual field control signal. i.e., board factory set for a 0-10 VDC control signal, jumper wire applied between poles 5 & 6, the indicated control RH level (via Menu #1) will be approximately 50%.
3. Adjust the control setpoint relative to the control RH level via Menu #2, keeping in mind the bandwidth, i.e., control RH level is 50%, Bandwidth is +/- 10%, adjust the control setpoint to 60%, or greater, to obtain 100% output from the unit.

Installation, Operation, & Maintenance Manual

Unit Detected Faults (Red Light is Illuminated)

Problem / Symptom	Probable Cause	Reason - Correction
Overcurrent When this condition occurs, the system has sensed an excessive current draw (138% of rated current) and has shut itself down and drained completely to prevent possible damage. The system has already taken preventative action by attempting to drain down prior to the fault condition occurring. Therefore, further analysis is required before restart is attempted.	Restricted Drain System	Clean and replace as necessary
	Use of softened water without adjusting operating parameters	See Fig. 30
	Water conductivity in excess of 750 micromho	See Fig. 30 and 31
	Expired steam cylinder – a mineral bridge has developed allowing a short between two electrodes.	Replace steam cylinder
	If drain tempering is enabled and the rate of fill is exceeding the rate of draining, the tank will fill whenever the unit tries to drain.	Adjust the fill valve metering screw to slow the rate of fill so the unit can drain properly. See Fig. 21 for adjusting screw location.
Fill System Fault The unit has been in fill cycle for 15 minutes continuously without reaching required output or cylinder full. System will shutdown and drain completely.	Restricted or blocked fill system (strainer, solenoid, external shut-off valve.)	
	Partially or completely open drain valve.	
	Extremely low conductivity supply water	
End of Cylinder Life The cylinder is full and humidifier has not been able to achieve desired output within setpoint.	Cylinder expired-electrodes have been consumed.	Replace
	Extremely low conductivity supply water	Add a 1/4 teaspoon of salt to the cylinder.
High Humidity Humidity in the space being measured by the control sensor has exceeded the pre-set alarm level. This alarm is only available on units configured with P + I control (mode 3).	Tampering with the control humidity setpoint.	1. Reset your alarm setpoint. 2. Turn off humidifier at main disconnect until humidification season.
	Alarm setpoint too close to control setpoint	
	Humidifier is powered but not operating and RH is above setpoint	
	Sensor or wiring has failed.	
Low Humidity Humidity in the space being measured by the control sensor has dropped below the preset alarm level. This alarm is only available on units configured with P + I control (mode 3).	Alarm setpoint too close to control setpoint	1. Turn the humidifier "on" to satisfy demand. 2. Adjust the low humidity alarm.
	Humidifier is powered but turned "off" and the RH is below the alarm setpoint.	
	Sensor or wiring has failed	
Slave Fault One of the 6 indicating faults has been detected in a slave unit.	Review of the slave units is required to determine specific fault conditions.	
Contactors Failed Unit has tried to turn on but contactor has not closed, or unit should be off, but contactor is still closed.	Failed contactor - It's common to find metal chips or other construction debris lodged in the contactor preventing proper operation	Repair or replace
	Faulty control wiring.	
	Auxiliary contact dislodged from proper position.	
	Faulty auxiliary contact	
	Installation with RDU's--the jumper between control terminal strip poles 1 & 2 needs to be removed.	

Cylinder Full Zero Current Cylinder full condition is present but zero amp draw is being sensed. Unit will continue to operate.	Faulty toroid transformer or wiring	Repair or replace. To check the toroid, measure the resistance of the toroid transformer. It should be approximately 8.5 ohms (+/- 1.5 ohm).
	Loss of one leg of main power	Check main terminal blocks. If line voltage is not present, check external fusing.
	Very clean water-less than 100 micromho	Contact your local water authority. If you are on a well, a complete water analysis should be performed. If you have any questions about the analysis, contact the factory.
Zero Electrode Current The electrode current is zero and it should not be.	Faulty toroid transformer or wiring	Repair or replace. To check the toroid, measure the resistance of the toroid transformer. It should be approximately 8.5 ohms (+/- 1.5 ohm).
	Failed drain system (stuck open)	Repair or replace. Operate drain valve with manual drain switch (Menu 5) to determine whether it is operating freely.
	Failed fill system (stuck closed)	Repair or replace. Check that external fill valve is open. Check that strainer is not blocked. Check to see that 24 VAC is at the coil of the fill solenoid.
	Excessively long cycle time (>150 seconds).	.
Non-Zero Slowly Decreasing Current The current is decreasing more slowly than it should during any automatic drain. The system will continue to operate but maintenance is required.	Defective drain system	Clean and/or replace as necessary. Check for partial blockage of drain valve, drain cup, or drain plumbing.
Non-Zero Non-Decreasing Current A worsening of the condition above. A complete blockage has occurred.	Block drain valve or drain system	Repair or replace as necessary.
	Failed drain valve or defective wiring	
Non-Zero Non-Increasing Amps System is not detecting increase in current draw during fill.	Faulty fill valve or wiring	Repair or replace.
	Blocked strainer	
	Water supply is shut off	
Air Flow / High Limit Unit has detected loss of airflow in air handling system or room distribution unit, or the optional on/off high limit setting has been reached	High limit setpoint has been exceeded at high limit humidistat	Check air handling system.
	Fan has stopped while there is still a demand for humidification.	
	Insure proper wiring for both air flow switch and high limit humidistat.	.
	Failed blower or air flow switch in RDU.	Repair or replace.
Cylinder Full Unit has detected water level at the top of the steam cylinder.	Low conductivity water supply – start-up condition	Install electrode jumper wires if not already connected (See page 21).
	Softened supply water	See softened water operating parameters in Fig. 30.
	Overconcentrated water in cylinder causing foaming	See hard water operating parameters in Fig. 30 or 31.
	Approaching end-of-cylinder life	
Humidity Sensor Failed Only available on units configured with a P+I control. The sensor has registered a humidity reading of 100% of more, or 4% or less for more than 5 seconds.	Failed humidity sensor or wiring	
	Position of humidity sensor too close to steam discharge	

Installation, Operation, & Maintenance Manual

<p>Communications Fault A short has been detected in the RS-485 communications loop.</p>		Maintenance is required.
<p>Green power lamp and LCD are not illuminated.</p>	<p>Blown 24 VAC control fuse</p>	Short in control wiring or microprocessor board if fuse blows immediately.
		Short in contactor or control wiring if fuses blow as unit energizes contactor.
		Short in fill valve or wiring if fuses blow after unit is attempting to energize the fill valve.
		Short in drain valve or wiring if fuses blow after unit has cycled and is now attempting to energize the drain valve.
	<p>Blown high voltage fuses</p>	Spike in power supply.
		Short in terminal blocks or contactor
<p>Main transformer failure</p>	Check for 24 VAC on secondary side of transformer between X1 and X2.	
	If secondary side is insufficient and proper voltage is being supplied to primary side of transformer, replace transformer.	
<p>Incorrect voltage to primary side of transformer</p>	<p>Confirm voltage supplied compared to tap on transformer and data plate. Measure AC voltage across the primary of the transformer for supplied voltage If insufficient, check path through terminal blocks, contactor and fuses for a potential drain. If every point of connection within the humidifier reads the same insufficient number, then the disconnect should be checked.</p>	
<p>Unable to turn unit on after pressing “on/off” button</p>		Open door and press “on/off” button again. If unit comes on, place 1 and 2 wires to the opposite side of the door interlock switch.
		Poles 1 & 3 on the controls terminal strip need to be jumped.
<p>Water always draining when drain solenoid is closed</p>	<p>Obstruction keeping the drain solenoid from closing</p>	Clean and/or replace.
<p>Display shows erroneous number and titles (such as “%*#~?/*@”)</p>		Press reset button on the back of the PC board
		Check for proper ribbon cable connections to LCD and PC board (see page 22, Item E)
		Replace ribbon connector, LCD and PC board.

Summary of Troubleshooting Tips for the Inputs and Outputs of the EST-1250 Circuit Board

Turn power ON to the unit (green power light should be ON) & verify proper sensor installation. If all of the 24 VAC inputs to the circuit board are energized, but ANY of the outputs from the circuit board are NOT indicated, the circuit board may not be operating properly.

1) Verify that these inputs to the circuit board are energized:

24 VAC Input to Board

At Connector J3

PIN 1, wire # 17
PIN 4, wire # 18
PIN 8, wire # 19
PIN 10, wire # 20

At Connector J5

PIN 1, wire # 37
PIN 2, wire # 45

At Connector J5

PIN 3, wire # 3

Source of 24 VAC Input to Board

At Terminal Block

Terminal 10, wire # 17
Terminal 9, wire # 18
Terminal 8, wire # 19
Terminal 7, wire # 20

At Terminal Strip

Terminal 3, wire # 16 (thru door interlock)
Terminal 2, wire # 45

At Auxiliary contact

Wire # 3

2) Verify that these outputs from the circuit board are energized:

24 VAC Output from Board

At Connector J3

PIN 5, wire # 34
PIN 9, wire # 23
PIN 11, wire # 13

DC Output from Board

At Connector J5

5 VDC at PIN 5, wire # 5
20 VDC at PIN 8, wire # 8
5 VDC at PIN 9, wire # 9

Output to Unit Display

From Connector J4

Board generates clear and legible two line display instead of a single row of black or gray blocks.

Function of 24 VAC Output from Board

Energize contactor coil, wire # 34
Energize drain solenoid, wire # 23
Energize fill solenoid, wire # 13

Function of DC Output from Board

At Terminal Strip

5 VDC available at terminal #10, wire # 5
20 VDC to power sensors from terminal #7, wire # 8
5 VDC to simulate sensor input at terminal #6, wire # 9

Inputs / Outputs of Terminal Strips and Terminal Block

Terminal Block

Position 1-6 24 RET (GND)
 7-12 24 VAC

All twelve (12) positions should be utilized if the Room Dispersion Unit (RDU) is installed

RDU Terminal Strip – Connections to RDU only

Pole

1 24 RET (GND) (Always)
 2 24 VAC Trigger (24 VAC when contactor is energized)
 3 Line Voltage (Always)
 4 Line Voltage (Always)
 5 24 VAC Air (24 VAC when switch Proving Switch is closed)
 6 24 VAC (Always)

Control Terminal Strip

Pole

1 24 VAC (Always)
 2 Airflow / High Limit input, 24 VAC for operation
 3 External "Off", 24 VAC for operation
 4 Control input ground – Modulating and on/off
 5 Control input signal – Modulating and on/off
 6 +5 VDC
 7 +20 VDC
 8 Limit input ground - Modulating
 9 Limit input signal - Modulating
 10 +5 VDC
 11 RS-485 Communication, Negative, Digital
 12 RS-485 Communication, Positive, Digital

Figure 30

Hard Water/Softened Water* (750-1000 Micromho) Adjust Menu Items to These Settings		
	MDM	MDS/ MDD
Cycle Time (Menu #3)	75	115
Low Drain Threshold (Menu #2)	88	84
Capacity Setpoint (Menu #2)	96	96
High Drain Threshold (Menu #3)	108	108

*Naturally soft water is less than 50 micromho.

Figure 31

Very Hard Water (> 1000 Micromho) Adjust Menu Items to These Settings		
	MDM	MDS/ MDD
Cycle Time (Menu #3)	60	100
Low Drain Threshold (Menu #2)	91	86
Capacity Setpoint (Menu #2)	94	92
High Drain Threshold (Menu #3)	105	105

NOTE

1. For On/Off (mode 1) units, a resistor (68.1 kohms) between poles 5 and 7 on the controls terminal strip is required. (34.0 kohms for MDD units)
2. If more than one MDS, MDM or MDD are “networked” together, a resistor may be required in socket R28 on PCB. (See pg.12)

Circuit Board: J1 Connector

PIN

- 4 Toroid Input, Non-polar
- 3 Toroid Input, Non-polar
- 2 RS-485 Communication, Positive, Digital
- 1 RS-485 Communication, Negative, Digital
- 5 Not Used

Circuit Board: J3 Connector

PIN

- 1 Power Input, 24 VAC
- 2 Power Input, 24 RET (GND)
- 3 Not Used
- 4 24 VAC, for contractor coil, (Always)
- 5 24 VAC, for contractor coil, switched
- 6 Alarm Output
- 7 Alarm Output
- 8 VAC, for drain valve, (Always)
- 9 24 VAC, for drain valve, switched
- 10 24 VAC, for fill valve, (Always)
- 11 24 VAC, for fill valve, switched

Circuit Board: J5 Connector

PIN

11. Door interlock input, 24 VAC to operate
- 10 Air flow/High Limit input, 24 VAC to operate
- 9 Auxiliary contact input, 24 VAC when energized and 0 VAC when de-energized.
- 8 Cylinder Full input
- 7 +5 VDC
- 6 Limit input signal – Modulating
- 5 Limit input ground – Modulating
- 4 +20 VDC
- 3 +5 VDC
- 2 Control input signal – Modulating and On/Off
- 1 Control input ground – Modulating and On/Off

Circuit Board: J3 Connector

PIN

- 1-14 LCD, 2-Lines X 20 Characters, non-backlit

Figure 32

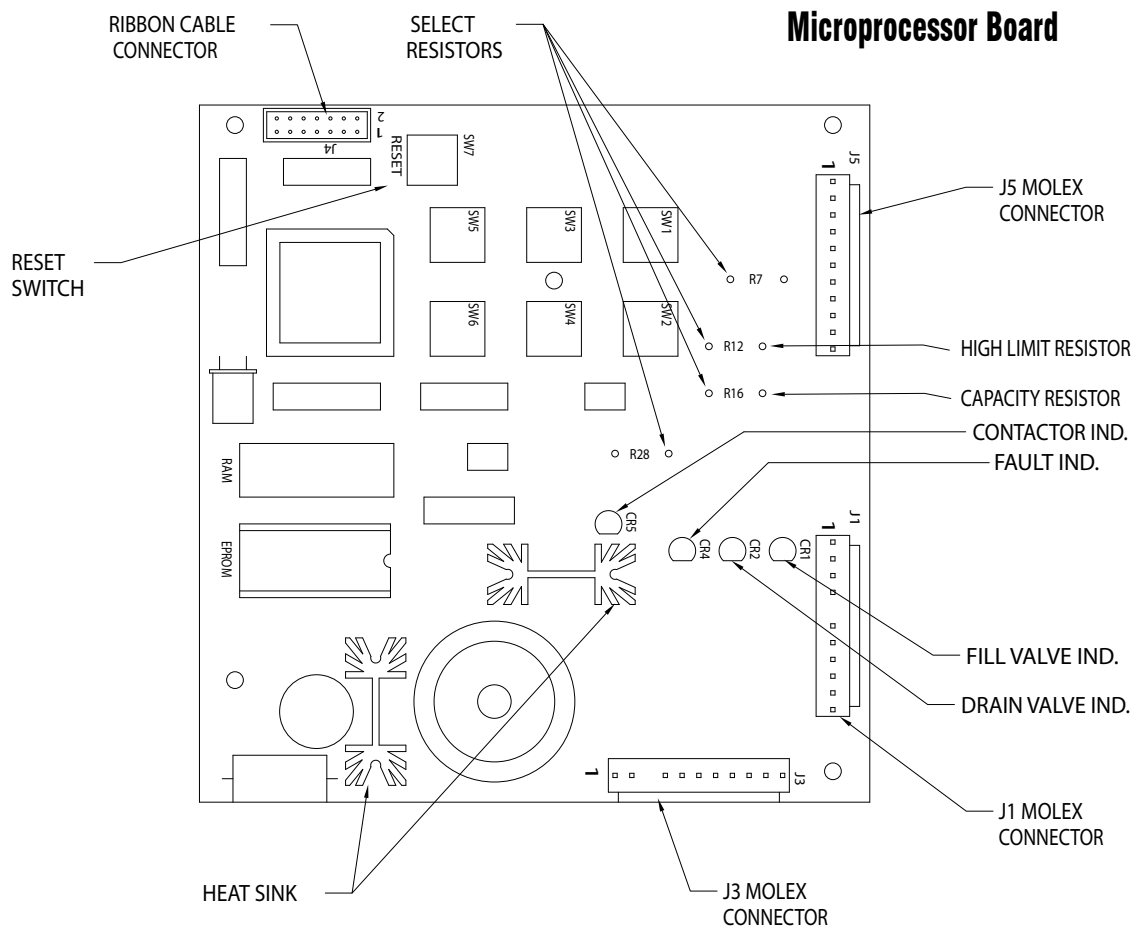

Replacement Cylinders

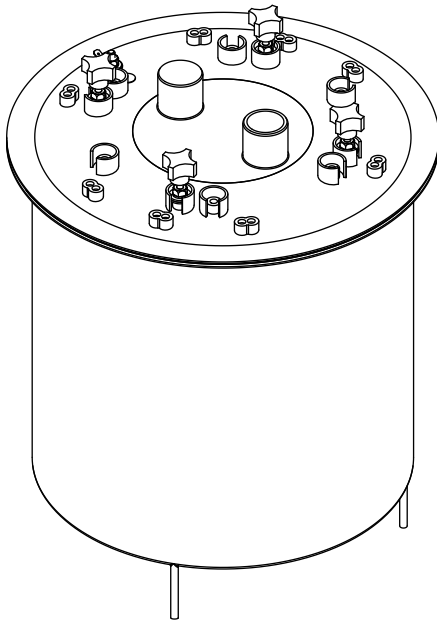

MDS Parts List:

<u>Item no.</u>	<u>Description</u>
EST-1002-4-1	Single Phase, 5-50 #/hr.
EST-1002-6-1	Three Phase, 5-50 #/hr. (shown)
EST-1002-6-2	Three Phase, 60-100 #/hr.

MDD Parts List:

<u>Item no.</u>	<u>Description</u>
EST-1002-6-2	Three Phase, 110-250 #/hr. (2) Tanks Required

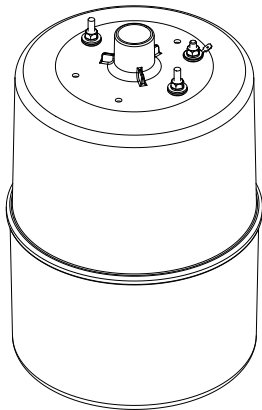

MDM Parts List:

<u>Item no.</u>	<u>Description</u>
EST-416-2	Single Phase, 5-15 #/hr. (shown)
EST-416-3	Three Phase, 5-30 #/hr.

Installation, Operation, & Maintenance Manual

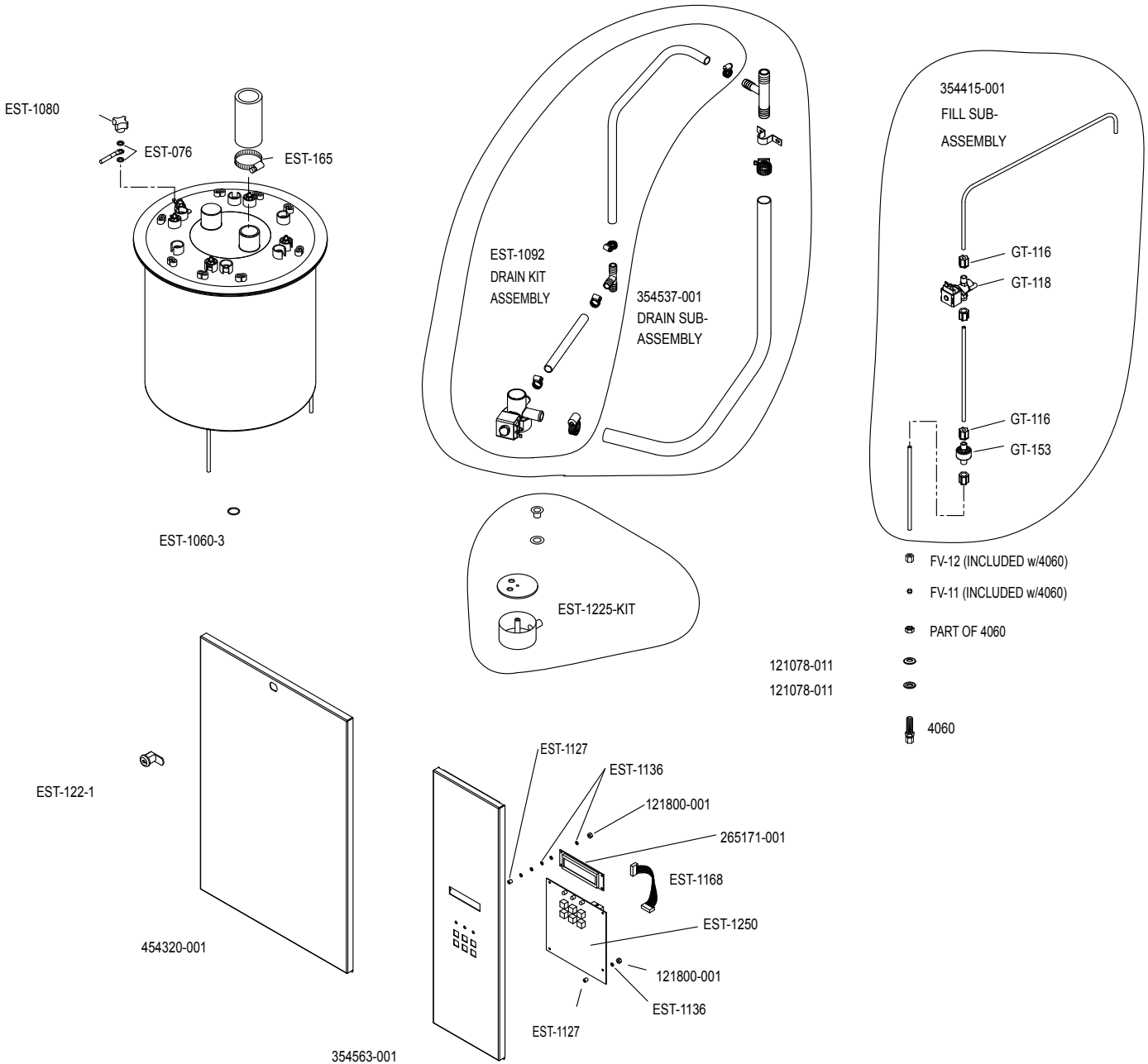

Model MDS - Parts Schematic

Installation, Operation, & Maintenance Manual

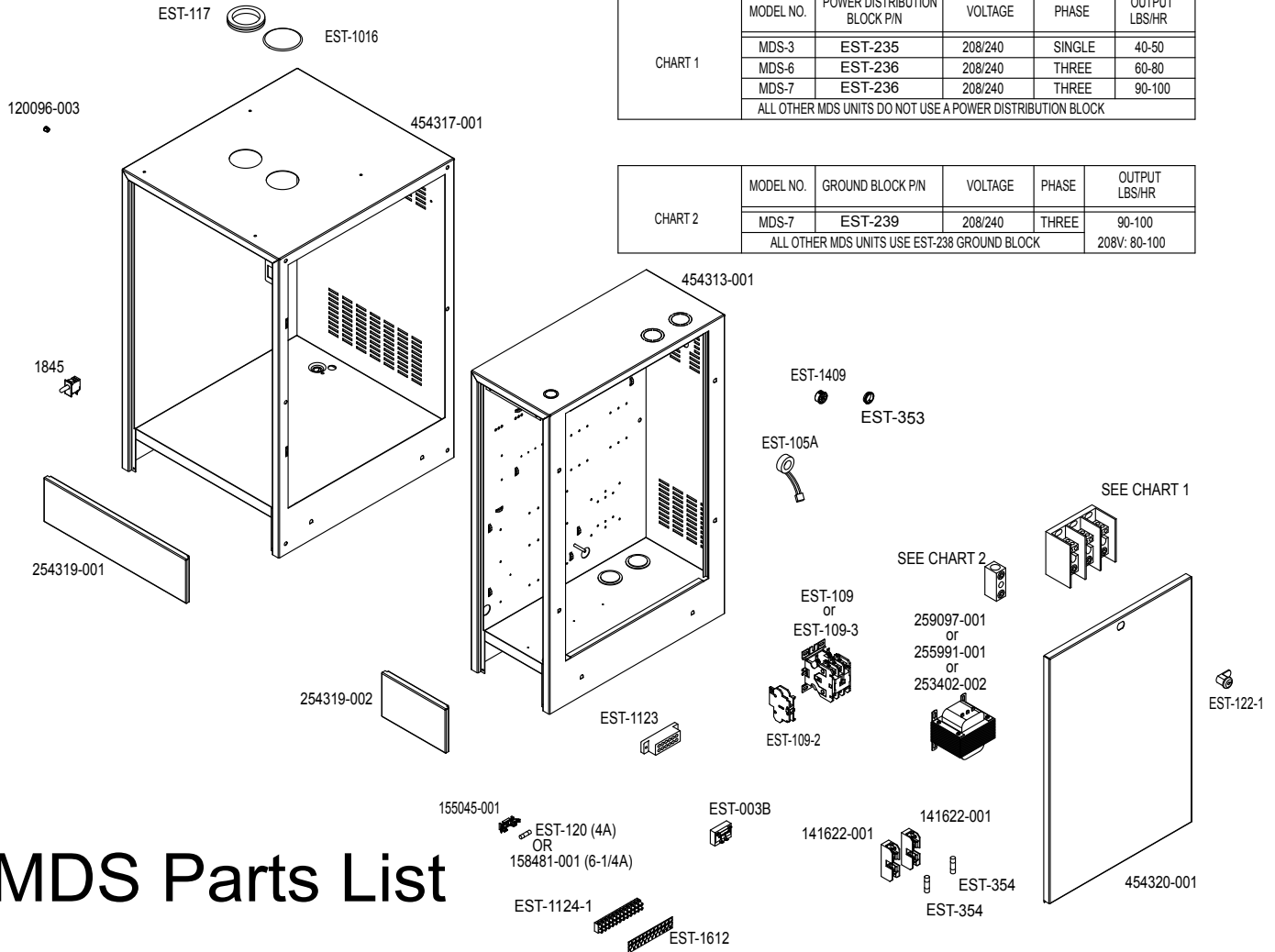

CHART 1	MODEL NO.	POWER DISTRIBUTION BLOCK P/N	VOLTAGE	PHASE	OUTPUT LBS/HR
	MDS-3	EST-235	208/240	SINGLE	40-50
	MDS-6	EST-236	208/240	THREE	60-80
	MDS-7	EST-236	208/240	THREE	90-100
ALL OTHER MDS UNITS DO NOT USE A POWER DISTRIBUTION BLOCK					

CHART 2	MODEL NO.	GROUND BLOCK P/N	VOLTAGE	PHASE	OUTPUT LBS/HR
	MDS-7	EST-239	208/240	THREE	90-100
	ALL OTHER MDS UNITS USE EST-238 GROUND BLOCK				

MDS Parts List

HERRMIDIFIER PART NO.	DESCRIPTION
EST-003B	Cylinder Full Interface
EST-076	Lock Washer, Stainless Steel
EST-105A	Toroid Transformer
EST-109	Contact, 3 Pole, 40 Amp
EST-109-2	Auxiliary Contact
EST-109-3	Contact, 3 Pole, 65 Amp
EST-117	Grommet, Steam Hose
EST-120	Control Fuse, 4 Amp
EST-122-1	Cabinet Lock with Keys
EST-165	SS Hose Clamp, Steam Hose
EST-171	Steam Hose
EST-235	Power Distribution Block, 175A, 1PH
EST-236	Power Distribution Block, 175A, 3 PH
EST-238	Ground Block
EST-239	Ground Block
EST-353	Shorty Bushing, 7/8"
EST-354	High Voltage Fuse, 600 V
EST-529C	Quick Connect, Cyl Full Electrode
EST-1016	Hole Plug, Steam Outlet, 2 1/2"
EST-1060-3	"O" Ring
EST-1080	Electrode Knob
EST-1092	Drain Kit Assembly
EST-1123	Terminal Block, 12 Position
EST-1124-1	Terminal Strip, 4 Amp
EST-1127	Spacer, Nylon #6
EST-1136	Washer, Nylon #6

HERRMIDIFIER PART NO.	DESCRIPTION
EST-1168	Ribbon Cable Assembly
EST-1225-KIT	Drain Reservoir Kit
EST-1250	Microprocessor Board, Provide Specific Model # and Control Arrangement.
EST-1409	Universal Bushing
EST-1612	Marking Strip for EST-1124-1
FV-11	Sleeve, Brass, 1/4" Compression
FV-12	Brass Compression Nut, 1/4"
GT-116	Celcon Compression Nut, 1/4"
GT-118	Metering Fill Solenoid
GT-153	Strainer
1845	Door Interlock Switch
4060	1/4" Comp. X 1/4" Comp. Brass Bulkhead Union
120096-003	Hole Plug
121078-011	Sealing Washer
121800-001	KEP Nut, 4-40
141622-001	High Voltage Fuse Holder
155045-001	Fuse Holder
158481-001	Control Fuse, 6-1/4 Amp
253402-002	Control Trans, 208/230/240/460/480V Primary, 150VA
255991-001	Control Trans, 208/230/380/460/600V Primary, 96VA
259097-001	Control Transformer, 208/230/460V Primary, 100VA
265171-001	LCD Display
354415-001	Fill Sub-assembly
354537-001	Drain Sub-assembly

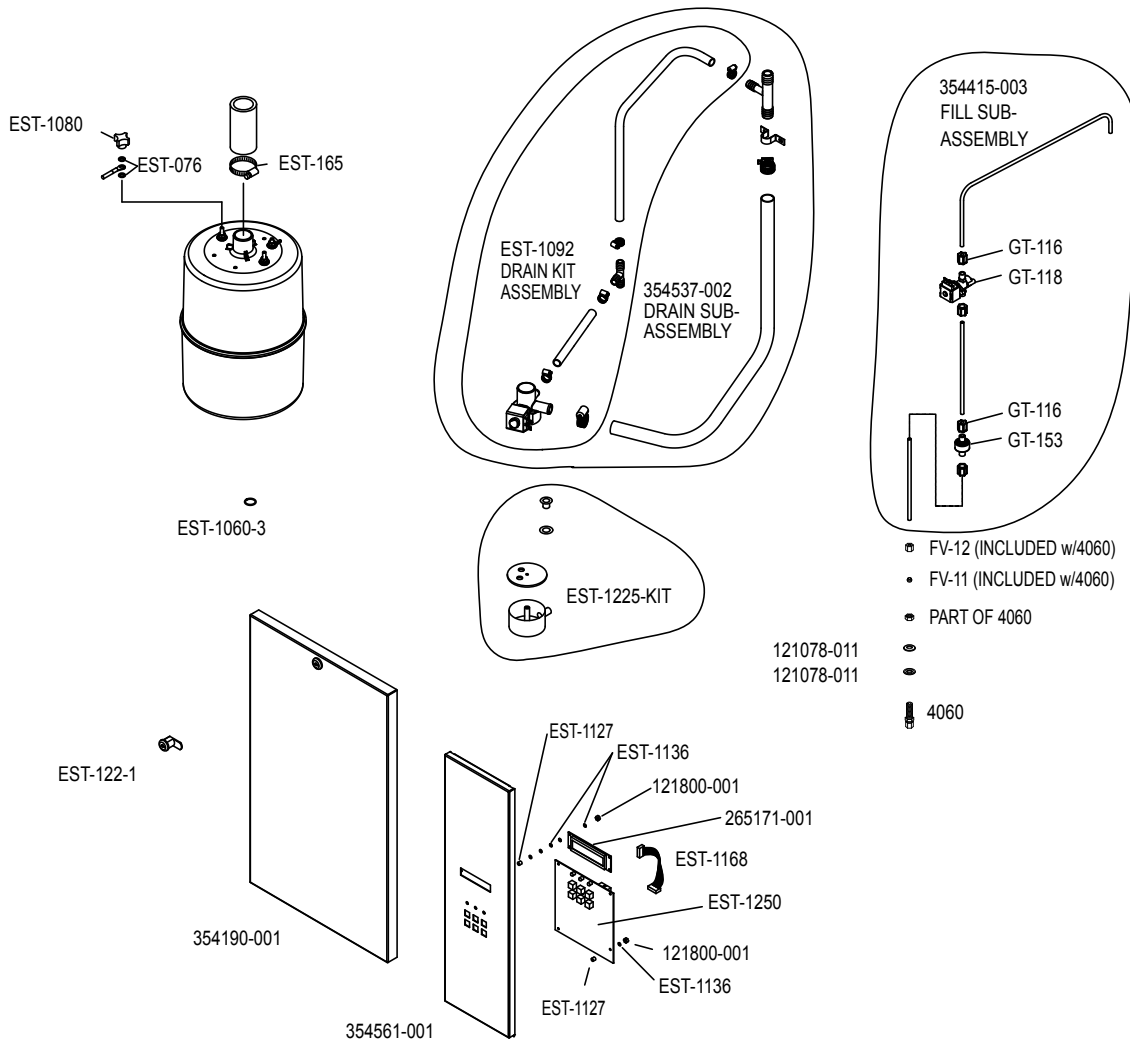

Model MDM - Parts Schematic

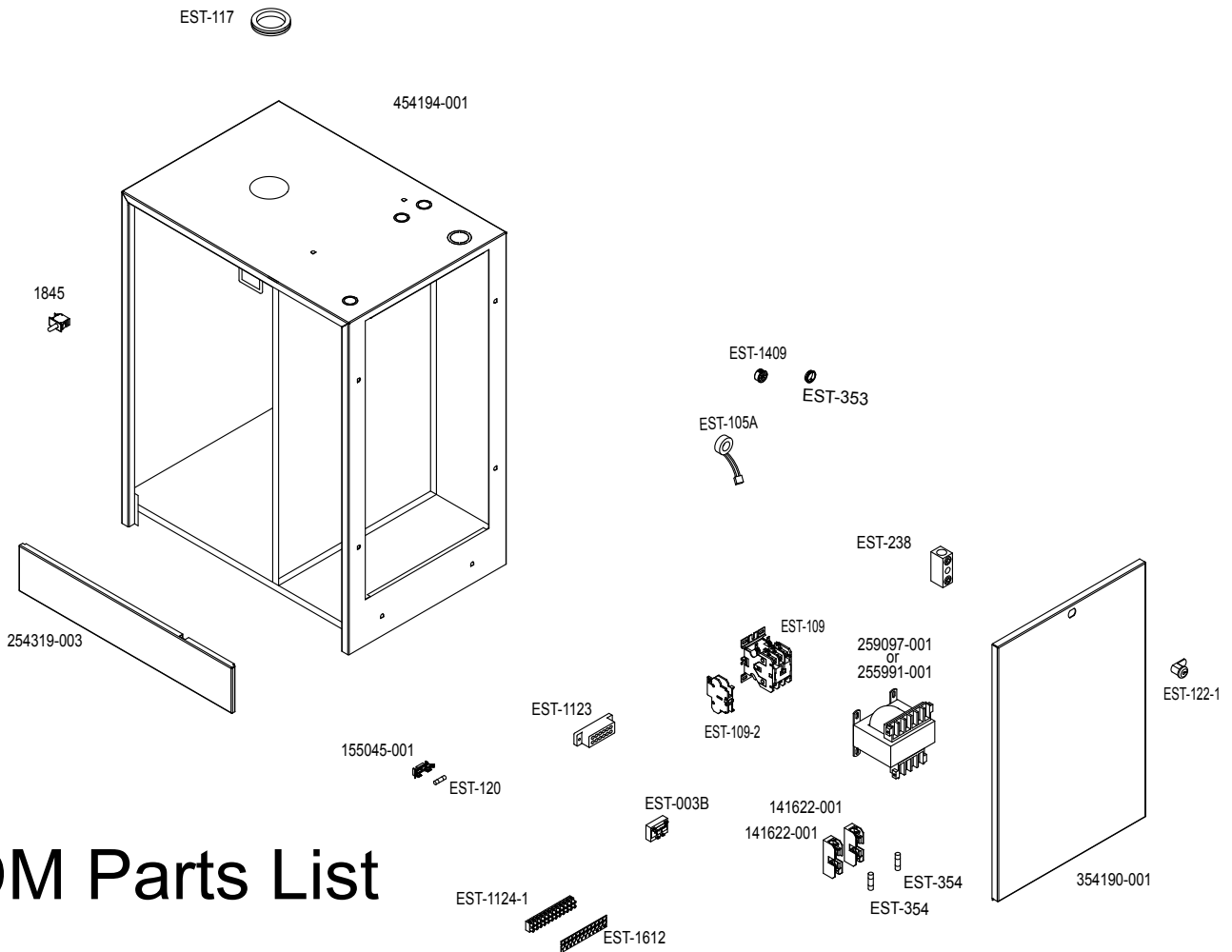

MDM Parts List

HERRMIDIFIER PART NO.	DESCRIPTION
EST-003B	Cylinder Full Interface
EST-076	Lockwasher, Stainless Steel
EST-105A	Toroid Transformer
EST-109	Contactora, 3 Pole, 40 Amp
EST-109-2	Auxiliary Contact
EST-117	Grommet, Steam Hose
EST-120	Control Fuse, 4 Amp
EST-122-1	Cabinet Lock with Keys
EST-165	SS Hose Clamp, Steam Hose
EST-171	Steam Hose
EST-238	Ground Block
EST-353	Shorty Bushing, 7/8"
EST-354	High Voltage Fuse, 600 V
EST-529C	Quick Connect, Cyl Full Electrode
EST-1060-3	"O" Ring
EST-1080	Electrode Knob
EST-1092	Drain Kit Assembly
EST-1123	Terminal Block, 12 Position
EST-1124-1	Terminal Strip, 4 Amp
EST-1127	Spacer, Nylon #6
EST-1136	Washer, Nylon, #6
EST-1168	Ribbon Cable Assembly

HERRMIDIFIER PART NO.	DESCRIPTION
EST-1225-KIT	Drain Reservoir Kit
EST-1250	Microprocessor Board, Provide Specific Model # and Control Arrangement.
EST-1409	Universal Bushing
EST-1612	Marking Strip for EST-1124-1
FV-11	Sleeve, Brass, 1/4" Compression
FV-12	Brass Compression Nut, 1/4"
GT-116	Celcon Compression Nut, 1/4"
GT-118	Metering Fill Solenoid
GT-153	Strainer
1845	Door Interlock Switch
4060	1/4" Comp. X 1/4" Comp. Brass Bulkhead Union
121078-011	Sealing Washer
121800-001	KEP Nut, 4-40
141622-001	High Voltage Fuse Holder
155045-001	Fuse Holder
255991-001	Control Transformer, 208/230/380/460/600V Primary - 96 VA
259097-001	Control Transformer, 208/230/460V Primary - 100 VA
265171-001	LCD Display
354415-003	Fill Sub-assembly
354537-002	Drain Sub-assembly

MDS / MDM WIRING DIAGRAM

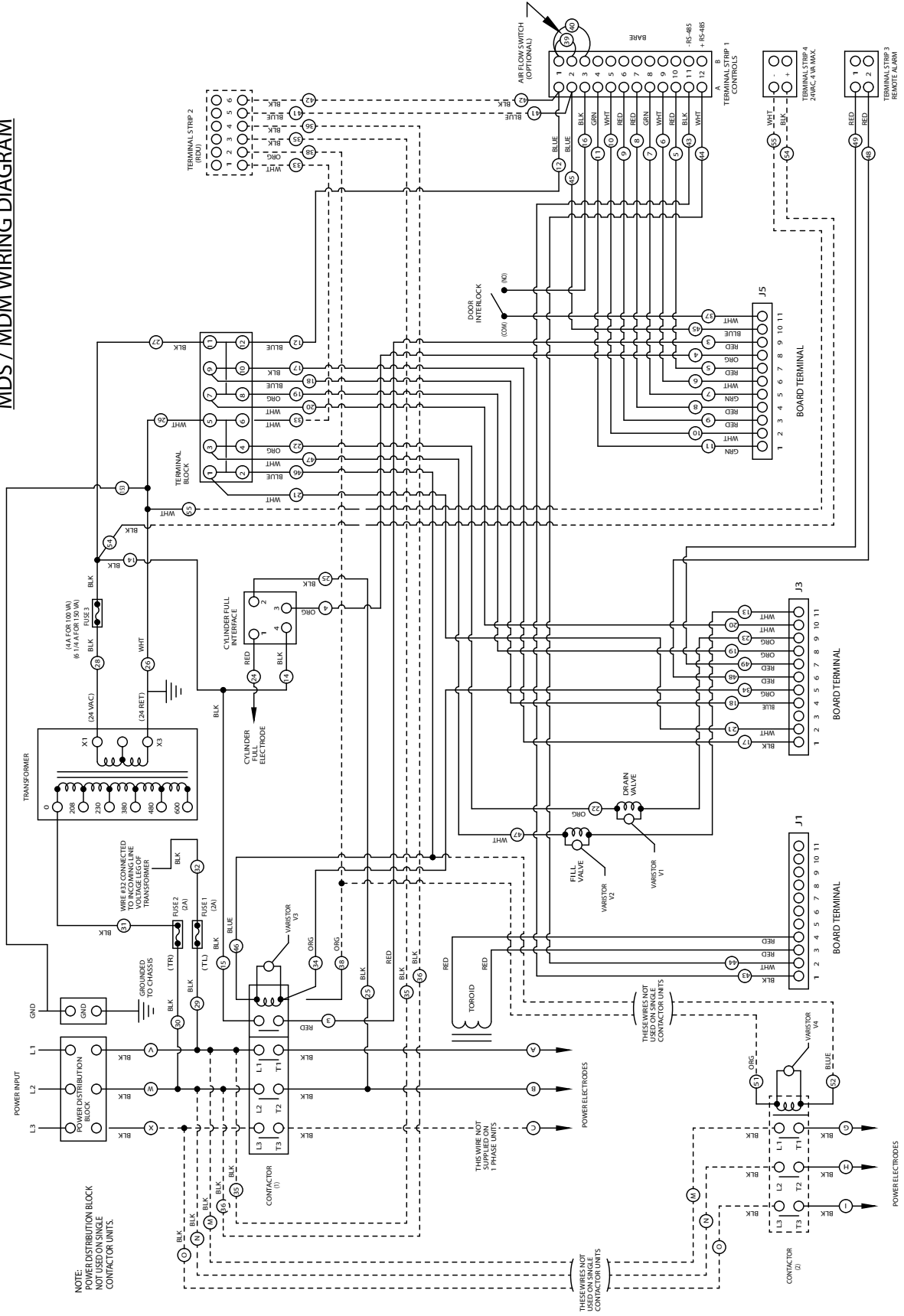



TRION®

101 McNeill Rd. | Sanford, NC 27330

P: 800.884.0002 | F: 800.458.2379 | www.trioniaq.com | customerservice@trioniaq.com
