

This Owner's Manual is provided and hosted by [Appliance Factory Parts](#).



Napoleon AS300K-2 Owner's Manual

[Shop genuine replacement parts for Napoleon
AS300K-2](#)



[Find Your Napoleon Grill Parts - Select From 264 Models](#)

----- Manual continues below -----



Wolf Steel Ltd.
214 Bayview Drive,
Barrie, Ontario, CANADA L4N 4Y8
grills@napoleon.com

Wolf Steel Europe BV
De Riemsdijk 22, 4004 LC, Tiel
The Netherlands
eu.info@napoleon.com



WARNING:

This product can expose you to chemicals including benzene, which are known to the State of California to cause cancer, and chemicals including carbon monoxide, which are known to the State of California to cause birth defects or other reproductive harm. For more information go to www.P65Warnings.ca.gov.

APOLL
Charcoal Grill



What's Inside

Instructions - How to set

Hints and tips - How to g

Recipes - Step-by-step g

Retain this manual for futur

N415-0590 AUG 14.20

Optional Accessories



Grilling Glove

Reversible - fits both left or right hand. Withstands temperatures up to 250 °C (475 °F). The silicone lines will ensure you never lose your grip when grilling.

Product Code: **62145**



Charcoal Chimney Starter

Light your charcoal with no lighter fluid and no mess in a Charcoal Chimney Starter. Made with a cool touch handle for easy and safe pouring.

Product Code: **67800**



Grid Lifter

No more struggling to lift the grid off a hot grill for refuelling or smoking. The sturdy construction lifts heavy, hot grids keeping your hands away from the heat.

Product Code: **62121**



Silicone BBQ Tongs

A welcome addition to your grilling accessories. The silicone tips make lifting and rotating food effortless. Also features a comfortable handle that is extra-long to keep you at a safe distance.

Product Code: **55015**



Pocket Thermometer

Provides the most accurate way of testing whether or not your food is cooked to perfection.

Product Code: **61004**



Marinade Injector

Use this oversize hypodermic-style needle to inject basting mixtures, marinades, melted butter and other liquid flavourings deep into the meat.

Product Code: **55027**



Wood Chips

Add some extra smokey flavour to your food with one of six wood chip flavours.

Product Code: **67001 - Mesquite**

67002 - Maple

67003 - Hickory

67004 - Whiskey

67005 - Cherry

67007 - Apple

1.

Napoleon Ap

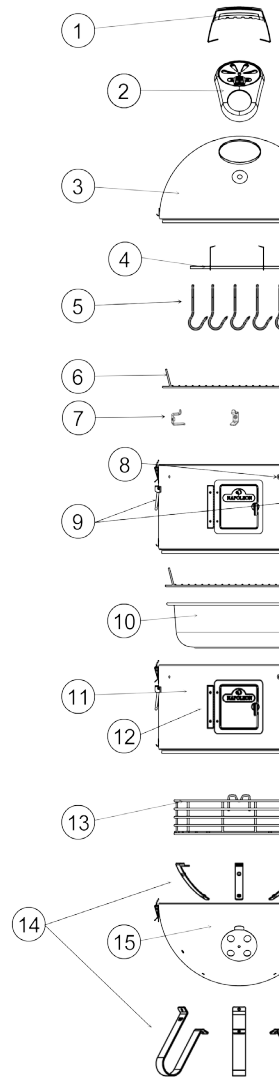

Napoleon Apollo AS300K-2 Parts List

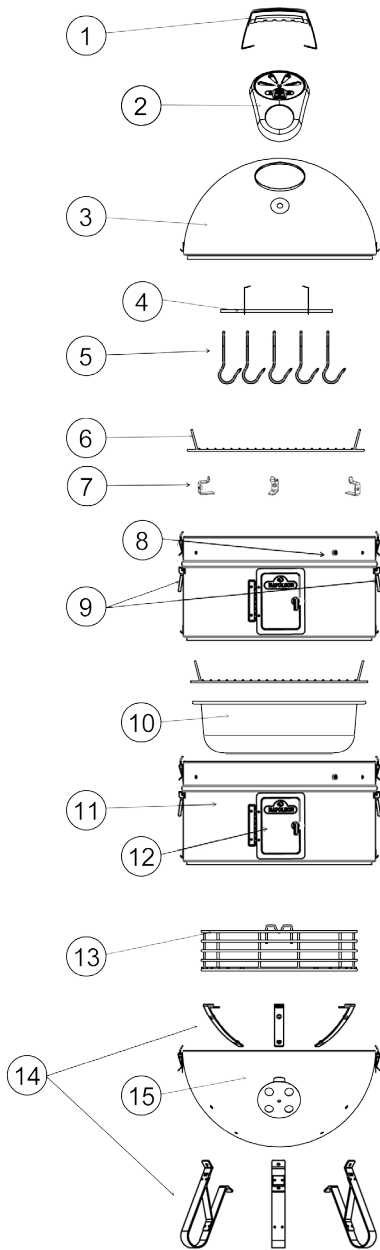

- 1** Handle Assembly
Part No. **AS-20191-1**
- 2** Temperature Gauge/Vent Bezel
Part No. **AS300K-20191-2**
- 3** Lid Assembly
Part No. **AS300K-20191**
- 4** Hanger Bar
Part No. **AS300K-20191-3**
- 5** Meat Hooks (x 5)
Part No. **AS-20191-4**
- 6** Cooking Grill
Part No. **AS300K-201906**
- 7** Brackets (x 3)
Part No. **AS-20192-5**
- 8** Silicon Probe Eyelets (x 2)
Part No. **AS-20192-6**
- 9** Side Handles
Part No. **AS-20192-7**
- 10** Water Pan
Part No. **AS300K-201907**
- 11** Stacker
Part No. **AS300K-20192**
- 12** Door Assembly
Part No. **AS300K-20192-8**
- 13** Charcoal basket
Part No. **AS300K-201905**
- 14** Leg and Bracket Kit
Part No. **AS300K-201904-9**
- 15** Base Bowl
Part No. **AS300K-201904**

APOLLO™ Smoker Features



Safety Instructions

Please read and follow these instructions before using your smoker, failure to do so may result in serious injury, death or a fire.

- This unit is designed for outdoor use only. Do not operate indoors or in an enclosed area
- Only use this smoker on a hard, level and non-combustible surface
- Do not leave the smoker unattended and keep children and pets away from the unit at all times
- Make sure there is at least 3 m (10') clearance between the unit and any combustible materials such as bushes, trees, wooden decks and buildings
- Do not attempt to move the hot smoker
- Use bbq/oven mitts at all times, as the surfaces will become hot
- The use of abrasive cleaners or sharp objects will damage the coatings
- Use extreme caution when adding charcoal or wood
- Do not use instant lighting charcoal, or flammable liquids. We recommend using a chimney starter with natural charcoal or charcoal briquettes
- Extinguish coals and ash after use and before leaving the smoker unattended
- Use common sense and caution when using this smoker
- To clean the smoker, a mild solution of warm, soapy water is all that is required

Warranty

NAPOLEON warrants that components in your new NAPOLEON product will be free from defects in material and workmanship from the date of purchase, for the following period:

Porcelain enamel lid and bowl.....10 years

Air control system.....5 years full coverage, plus 50% off until the 10th year

Porcelain-enameled cast iron cooking grids

.....5 years full coverage, plus 50% off until the 10th year

Chrome plated cooking grids.....3 years full coverage, plus 50% off until the 10th year

All other parts.....2 years

To obtain repair or replacement under the terms of this warranty, please call Customer Care at 1-866-820-8686 for complete details. Napoleon's obligations under this warranty are limited to the following guidelines.

The warranty does not cover smokers that have been altered or damaged due to: normal wear, rust, abuse, improper maintenance, improper use, disassembly of parts and/or attempted repair by anyone other than an authorized employee of Napoleon®. This warranty does not cover surface scratches or heat damage to the finish, which is considered normal wear. Napoleon® may elect to repair or replace damaged units covered by the terms of this warranty. The warranty extends to the original purchaser only and is not transferable or assignable to subsequent purchasers. Except as above stated, Napoleon® makes no other express warranty. The implied warranties of merchantability and fitness for a particular purpose are limited in duration to one year from the date of purchase.

3.

Mediterranean Chicken

Pesto (You may also use ready-made pesto)
750 mL (3 cups) fresh basil leaves (packed)
45 mL (3 tbsp.) lightly toasted pine nuts
2 cloves roughly chopped garlic
125 mL (½ cup) freshly grated parmesan cheese
125 mL (½ cup) extra virgin olive oil
salt and pepper to taste
pop all the ingredients into a blender

Rub (Use Napoleon® Chicken & Rib Rub)
15 mL (1 tbsp.) course sea salt
22.5 mL (1½ tbsp.) cracked pepper
15 mL (1 tbsp.) dried rosemary
15 mL (1 tbsp.) dried oregano
15 mL (1 tbsp.) ground coriander
If you like a bit of a “kick,” add some cayenne pepper
in a mixing bowl.

Chicken

1 large, preferably free range-chicken
refrigerator or under cold water.

Preparation: Loosen the skin of the chicken
between the skin and flesh. Once you have
bird until the pesto is evenly distributed
it all over the outside, then sprinkle
to stick).

Place the bird on the cooking grill
for water smoking and the charcoal
the bottom door and throw on some
running at between 93 °C (200°F) and
around 3½ hours. Remember to use

Tip: Let the chicken “rest” for at least

Cold Smoked Fish

Basic brine for fish...

- 125 mL (½ cup) brown sugar
- 125 mL (½ cup) kosher or coarse sea salt
- 250 mL (1 cup) soy sauce
- 1.5 L (6 cups) water
- 250 mL (1 cup) dry white wine
- 5 mL (1 tsp.) coarse ground pepper
- 1 finely chopped sprig of rosemary

You may need to increase the quantities proportionately depending on how much you need to cover your fish.

Method...

1. Mix all the ingredients and stir thoroughly until the salt and sugar has dissolved. Place the fish into a non-reactive container and pour the brine mixture over, making sure that the fish is totally covered by the brine.
2. Refrigerate overnight.
3. Remove the fish from the brine (the brine has done its work, so should now be disposed of), pat the fish dry and place back into the fridge for 2 hours.
4. Set up your unit for cold smoking, as described previously, place the fish on the cooking grills or you may want to use the fish hanger located in the lid. Pop the lid on and smoke.

Times will vary greatly depending on the size and weight of the fish. Mild woods such as Alder, Apple, Beech or Maple are recommended for smoking fish.

Thank you for purchasing the Apol...
to use your new unit safely and eff...
great-tasting food for your family a

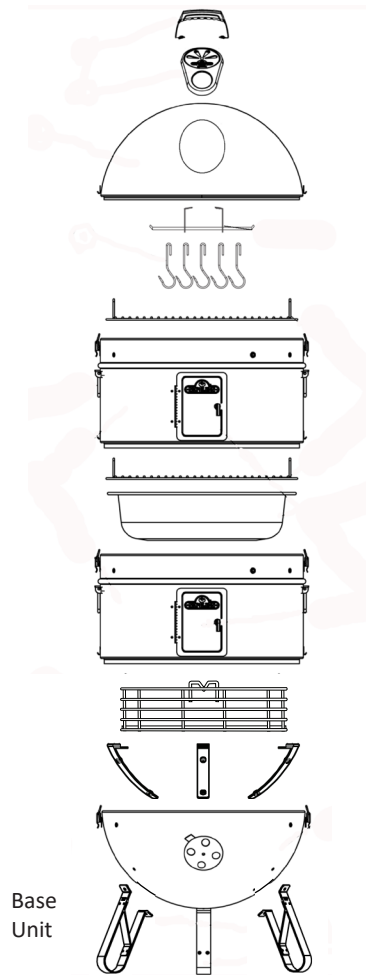

Food smoking is easy!

When smoking food, you want to slow down the cooking process, avoiding the temptation to “fiddle” with your food when smoking often results in better tasting food. You will want to cook food at temperatures of between 93 °C (200°F) and 120 °C (250°F) (Hot Smoking). You can smoke any type of food.....from vegetables to large cuts of meat, even whole turkeys, and on a relatively small unit you can cook a load of food. The Apollo® smoker incorporates many innovative features making them easy for you to use. Some of the features and other food smoking terms:

Water Pan - A water pan positioned between the food and fire acts as a buffer, making it almost impossible to burn food. It also serves to stabilize the cooking temperature and provides a moist cooking environment. **Tip:** Add beer, wine and/or herbs to your water pan for extra flavour.

Rub – Dry or wet, a mixture of spices and herbs that is applied (rubbed) to the outside of the food.

Wood – Wood for smoking comes in various forms, chunks, chips, dust and pellets, it also comes in many varieties (flavours) from apple to walnut, each imparting a different taste. **Tip:** Use only wood that you know has not been treated, or better still buy from an outlet that can advise you correctly.... see your authorized Napoleon® dealer.

Cooking Grill/ Rack – This is where you place the food on the cooker/smoker.

Charcoal – Like wood, it comes in an array of shapes and styles, lump or briquettes. Charcoal provides the heat source and if used correctly should not impart any flavour to your food... let it burn until the surface is covered with a layer of grey ash (once you’ve become a seasoned BBQ’er, you can worry about using techniques like the “minion” method to get longer burn times). **Tip:** Always use high quality charcoal, remember some contain binders that may not be good for you.

Charcoal Chimney Starter – This is an excellent invention, it allows you to light charcoal without the need for liquid starter, all it requires to get your charcoal going quickly, safely and cleanly is some rolled up newspaper. It also allows you to top up your charcoal basket easily. **Tip:** Wear closed shoes when handling hot charcoal. Good quality BBQ mitts are also essential.

Probe Thermometer – An essential tool for determining when the food is cooked. Insert a probe into the thickest part of the food (be sure to avoid hitting a bone as this will give a false reading) you can then use the reading to see whether the food has reached the desired temperature, a chart can be found further on in this manual. **Tip:** The smoking process makes some meats turn pink, so don’t mistake this for being raw.

5.

Roxy’s Spicy Apple BBQ Sauce

3 baking apples, peeled, cored and sliced
2 cloves garlic puree
15 mL (1 tbsp.) olive oil
125 mL (1/2 cup) water
375 mL (1 & 1/2 cups) ketchup
180 mL (3/4 cup) cider vinegar
60 mL (1/4 cup) molasses
125 mL (1/2 cup) turbinado sugar or sugar
125 mL (1/2 cup) cane syrup

In a sauce pan over medium heat add oil for 5 minutes till onions become translucent. Increase heat to low and simmer till the apples are soft. Add the remainder of ingredients and simmer till sauce is thickened. Add remaining ingredients to a blender and process till smooth.

Mack’s All-purpose BBQ Rub

Use teaspoons, cups or whatever to measure. If you use the same size of container for all measurements, it will be fine. This rub works on ribs, steak, etc.

1 measure ground fenugreek
3 measures coarse sea salt
4 measures demerara sugar
1 measure garlic powder
6 measures ground paprika

Mix all the ingredients together and store in a jar. It’ll last a couple of months.

Stuffed and Rolled Brisket

All you require for this dish are a few ingredients, coarsely chopped garlic, salt, pepper, coarse grain mustard, some natural string and plenty of time. Once you get the brisket home, the first thing you need to do is cut the string and unroll the brisket, if it's already rolled, paying attention to how it all fits together, as you will need to roll it up again. With the brisket laid out flat (fat side down) slather it with mustard, put the chopped garlic on and season liberally with the salt and pepper. At this point, you can slice some cheese on to it (optional) before rolling it up again. Use a natural cotton string to tie it all together again. Slather the outside with mustard and season with salt and pepper (herbs of your choice can be sprinkled on too). Wrap the brisket in cling film and leave it in the fridge overnight. Early the next morning (it will take 8 – 12 hours to cook, depending on the size of the cut), set the unit up for water smoking and place the brisket on the cooking grill and close the lid. Pop some wood on through the bottom door for smoke flavour. This is where the time ingredient comes in; find something to occupy your time as you wait for the low heat (93 °C (200°F) and 120 °C (250°F)) and smoke to work its magic.

Brisket takes time and practice. If you are monitoring the internal temperature of the meat, you will probably notice that after about 5 hours the temperature will sit at around 71 °C (160°F) for a while, don't panic, as it will start to rise again. When it has reached 88 °C (190°F), your brisket is cooked, but you will need to let the meat rest for at least half an hour, before carving and serving.

Wood Types

Wood Type	Characteristics
ALDER	Very delicate with a hint of sweetness. Best for light-meat game birds.
ALMOND	A sweet smoke flavour, good for poultry.
APPLE	Very mild with a subtle sweetness. (turns skin dark brown).
ASH	Fast burner, light but dries out quickly.
BIRCH	Medium hardwood with a light smoke. Good for poultry.
CHERRY	Good with poultry, pork and lamb. One of the best woods for smoking.
GRAPEVINES	Tart. Provides a lot of smoke. Good for meats, game and lamb.
HICKORY	The King of smoking woods. Good with pork, ham and beef.
LILAC	Very light, subtle with a hint of sweetness.
MAPLE	Smoky, mellow and slightly sweet. Good for small game birds.
MESQUITE	Strong earthy flavour. One of the hottest burning woods.
MULBERRY	The smell is sweet and slightly tart.
OAK	The queen of smoking woods. Good for meat, pork, fish and herbs.
ORANGE	Produces a nice mild smoke. Good for poultry.
PEAR	A nice subtle smoke flavour. Good for poultry and pork.
PECAN	Sweet and mild with a hint of bitterness. Good with pork.
PLUM	Great on most white meats and fish.
WALNUT	Very heavy smoke, usually used with apple. Can be bitter.

Quick Reference Cooking Chart

The chart below shows estimated cooking times, based on the smoker running at 110 °C (230°F). Outside factors such as wind and ambient temperature will have an effect on the actual time it takes to cook food. Internal temps are taken at the thickest part of the meat, using a good quality probe thermometer. We strongly recommend the use of a probe thermometer to check for doneness.

Food	Cut	Time	Internal Temp
Beef			
Sirloin	Roast	3 - 4 Hrs	Rare 50 °C (125 °F) Med 60 °C (145°F) Well 70 °C (160 °F)
Brisket	Roast	6+ Hrs	85 °C (190 °F)
Ribeye	Steak	5 – 15 Min-utes	Rare 50 °C (125 °F) Med 60 °C (145 °F) Well 70 °C (160 °F)
Poultry			
Chicken	Whole	3½ - 4 Hrs	75 °C (165 °F)
Chicken	Breast	25-35 Mins	75 °C (165 °F)
Chicken	Thigh	25-35 Mins	75 °C (165 °F)
Turkey	Whole	6 – 8 Hrs	75 °C (165 °F)
Fish			
Salmon	Whole	2 – 3 Hrs	60 °C (140 °F)
Salmon	Fillet	30 – 40 Mins	60 °C (140 °F)
Prawns	Whole	10 – 15 Mins	Cook until pink
Pork			
Shoulder	Whole	12+ Hrs	85 °C (190 °F)
Loin	Roast	4 – 5 Hrs	65 °C (150 °F)
Ribs	Rack	5 – 6 Hrs	65 °C (150 °F)

Delicious Duck

1 duck (fresh not frozen)
250 mL (1 cup) freshly squeezed orange juice
125 mL (½ cup) soy sauce
60 mL (¼ cup) dry sherry
2 cloves of garlic (finely chopped)
5 mL (1 tsp.) mustard powder
4 thin slices of orange
salt and pepper to taste

Combine the orange juice, soy sauce, sherry, garlic, mustard powder, salt and pepper in a bowl and mix thoroughly.

Place the duck in the bowl and gently massage the mixture and refrigerate overnight or at least 24 hours. Remove the duck from the bowl and pierce the skin in several places with a sharp knife while cooking. Lift the skin carefully from the breast (2 on each side). Allow the duck to rest for 15 minutes before serving.

Once the smoker is ready, water pan, place the duck on the cooking grill. Put the lid on the smoker and add the wood of your choice to the fire. Cook the duck for about 4 hours at 105 °C (220 °F), until the internal temperature reaches 75 °C (165 °F).

Pulled Pork

1 2½ - 4 kg (5.5 - 9 lbs.)pork shoulder roast, bone-in (aka pork or Boston butt).
Napoleon's bbq sauce
1 jar english mustard.
Mack's All Purpose Bbq Rub
15 mL (1 tbsp.) chili powder
30 mL (2 tbsp.) paprika
15 mL (1 tbsp.) cayenne pepper

15 mL (1 tbsp.) fresh ground black pepper
15 mL (1 tbsp.) garlic powder
15 mL (1 tbsp.) onion powder
30 mL (2 tbsp.) sea salt
15 mL (1 tbsp.) dried rubbed oregano
15 ml (1 tbsp.) cumin
5 ml (1 tsp.) coriander seeds, crushed
15 ml (1 tbsp.) mustard seeds, crushed

1. Score the skin and apply the mustard, ensuring that the roast is completely covered (the mustard flavour will not be prevalent at the end of the cooking process). Generously apply the rub, again making sure to cover the roast completely. Wrap in cling film and refrigerate overnight.
2. Remove the roast from the fridge about half an hour before you want to cook, this will ensure that it is at room temperature. Get the charcoal going and place the water pan in position. Place the roast on the cooking grill. The cook should take about 9 hours, so make sure you are using a full load of good quality charcoal and keep the smoker temperature between 93 °C (200°F) and 120 °C (250°F).
3. Add wood chips or chunks through the bottom door on to the fire to create smoke, Hickory or Mesquite wood work well with pork. You will need to monitor the internal temperature of the meat, you will probably notice that after a while, the temperature will sit at around 160°F for a while, don't panic, as it will start to rise again.
4. When it has reached 90 °C (195 °F) – 93 °C (200 °F), your butt is cooked, but you will need to let the meat rest for at least half an hour, before "pulling" (shredding/ breaking apart).
5. Serve on fluffy white bread rolls with Coleslaw and let your guests pour on as much sauce as they like.

Whole Chicken



What
news
match

The Fi
charco
cavity
on a r
charco
The ch
Pour t

Water
(by usi
cookin
stacke

The Fo
it out
grill ju
using
these
you ne
higher
food is
buy th

The Sr
bottom
directl
the do
OPEN

you ne
base u
tempe
during
handfu

not sm
The B
tempe
the ch
therm
shoul

Quick Tips

- Use hot water in the water pan at the start, this will allow the unit to come up to the desired temperature a lot quicker.
- Make sure that the air vent in the lid is kept fully open during use, failure to do so will disrupt the airflow and may result in the fire going out.
- If you're looking, the food's not cooking. Every time the lid is lifted to inspect the food, it will take up to 30 minutes for the smoker to come back up to the required temperature. Familiarity and the use of probe thermometers will reduce the need to inspect the food visually.
- Start with a small amount of wood to create smoke on your first few attempts, as it is very easy to "over smoke" food and remember, to get a smoke flavour all that is required is a wisp of smoke, smoke billowing out of the unit is not desired and will often leave a sooty deposit on the food which doesn't taste good.
- Use a good quality lumpwood charcoal or charcoal briquettes. Some brands of fuel have unsavory fillers and may impart an unpleasant flavour to the food.
- Buy good quality ingredients, as this makes all the difference.
- Allow the food to come up to room temperature by taking it out of the refrigerator at least 30 minutes before you intend to cook it. Meat at room temperature allows smoke to penetrate more.
- Use only tried and tested non-resinous woods, see chart in manual.
- Try to source wood that has no bark on it, as the bark can contain bugs and other nasties that may be poisonous.
- Most importantly... experiment! Try different woods, rubs and sauces until you come up with the combination that suits your taste buds. We've included a few recipes in this booklet, but feel free to add your own twist to them.

Low and Slow Spare Ribs

The important thing to remember is that you get the best quality available... ing them, so you don't want to start no matter how you prepare and cook

1. Prepare ribs by removing the Trim off any loose fat or meat
2. Pat the ribs dry using a paper ribs completely. You can use blend a few dried spices and use a "foodsaver" bag (one t overnight.
3. Remove the ribs from the fr cook them; this will ensure t ribs with Napoleon's bbq sau sauce/ ketchup, honey and w
4. Get the charcoal going and p ribs on the cooking grill/rib ra so make sure you are using a the smoker temperature betw
5. Add wood chips or chunks th smoke, this should be done f ribs every hour during this pe
6. After 3 hours, remove the rib heavy duty tin foil, baste hea them, making sure there are the smoker for another 2 ho °C (200°F) and 120 °C (250°F) on the fire at this stage).
7. Remove the foil from the ribs
8. After 6 hours total cooking t grills onto the fire bowl brack 30 seconds, caramelizing the

Salmon Steaks

6 salmon steaks (1- 1.5 inches thick)
500 mL (2 cups) cold water
30 mL (2 tbsp.) sea salt
7.5 mL (1-1/2 tsp.) white wine vinegar
5 mL (1 tsp.) dried mixed herbs
60 mL (1/4 cup) extra virgin olive oil

Combine the water, salt, vinegar and mixed herbs. Stir until salt dissolves.

Place the fish steaks into a non-reactive dish (glass) and pour the mixture over. Cover and refrigerate for 30 minutes, use this time to set up your smoker.

Once the smoker is ready, water pan in and filled about 1/2 way, place the steaks on the cooking grill. Put the lid on (remember to open the lid vent fully) and add the wood of your choice to the charcoal, using the bottom access door.

We recommend a mild wood such as Alder for fish. Cook for about 2 hours at 104 °C (220 °F), or until the fish flakes easily.

Cold Smoking

Cold smoking is used to cure, rather than cook, food. Foods prepared in this method include fish. That “cold” smoking is a little harder than hot smoking, we would suggest buying a book that covers the topic, such as *Home Smoking and Curing* by Keith Kessler. Cold smoking is done, as the name suggests, at a low temperature (50-60 °F). For this reason, not all days are good for cold smoking. Some of the year are best. For some meats, a brine is used before the food is smoked. A brine

Cold smoking on your Apollo® Smoker

1. Get 4 or 5 charcoal briquettes. If they have a grey appearance, place them in a metal basket for this type of smoking.
2. Cover the briquettes with wood chips. Let the wood to smolder, plus re-charge the wood. For this, it should produce smoke.
3. Place the water pan in its usual position. Fill with water or leave dry. This will help keep you may need cold water to keep the temperature down below 30 °C (85 °F).
4. Place the food on the cooking grill. If the lid vent, it must remain fully open.

With cold smoking, it is important to monitor the temperature all times. We suggest using a digital thermometer.

Cooking times will vary greatly depending on the food. For instance, cheese will only take a few hours, while meat will take 10 – 12 hours. Meat such as h

Brines

Brines are generally used on white meats such as fish or poultry and are used to produce a juicier and more flavourful end product. The brining process will enhance food that is to be either “Hot” or “Cold” smoked. Before you start brining, there are a couple of basic rules to follow.

6. Containers: as a brine is basically a salt solution, the containers need to be clean and made from a nonreactive material. Plastic tubs or stainless steel or glass containers are fine.
7. Before putting your meat into the brine, the temperature of the brine must be about 3-4 °C (38-40 °F) this temperature needs to be maintained throughout the process. The best way to achieve these temperatures is to either refrigerate, or by adding ice cubes to the brine mixture. A good quality digital thermometer will help with monitoring this.
8. Make sure the meat is fully covered by the brine.
9. Brines can NOT be reused.

Basic Brine Recipe

60 mL (1/4 Cup) of Kosher salt
60 mL (1/4 Cup) of brown sugar
1 L (4 Cups) of water

In a medium bowl, combine the salt, sugar and water. Stir vigorously until all the salt and sugar has dissolved. Then pour this mixture over the meat, poultry, or fish that you are preparing. Soak for several hours, or overnight. You may need to increase the quantities in order to ensure that the meat is fully submerged.

* You may wish to add some herbs or spices to the basic recipe.

Smoked Cheese

Smoked cheese is easy to do on your smoker. It is a much superior to the smoked cheese you can buy.

Set up your smoker for cold smoking. Place the cheese on the cooking grills, pop the top and smoke.

Cheese absorbs smoke quickly and you can smoke it for several hours. Start at the lower end of the smoker. The cheese won't change colour much; this is a good thing. If you want a darker, due to not being naturally smoked, spray on. Mild woods are best.

