

This Owner's Manual is provided and hosted by [Appliance Factory Parts](#).

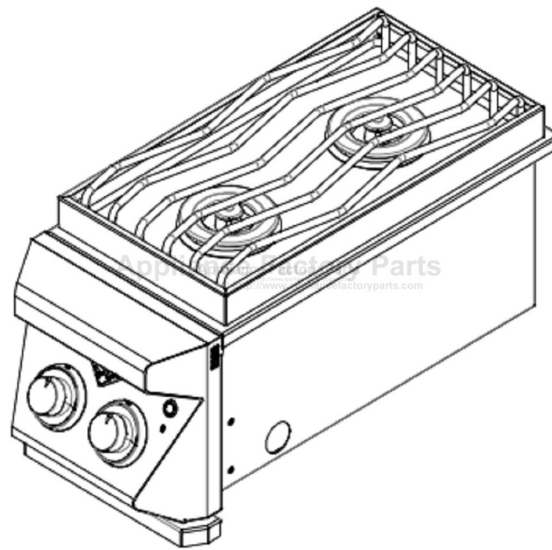

TWIN EAGLES TESB131-C Owner's Manual

[Shop genuine replacement parts for TWIN EAGLES
TESB131-C](#)



[Find Your TWIN EAGLES Grill Parts - Select From 58 Models](#)

----- Manual continues below -----



TWIN EAGLES

U S A

INNOVATION AND INSPIRATION ON FIRE™

SIDE BURNERS INSTALLATION, USE & CARE MANUAL

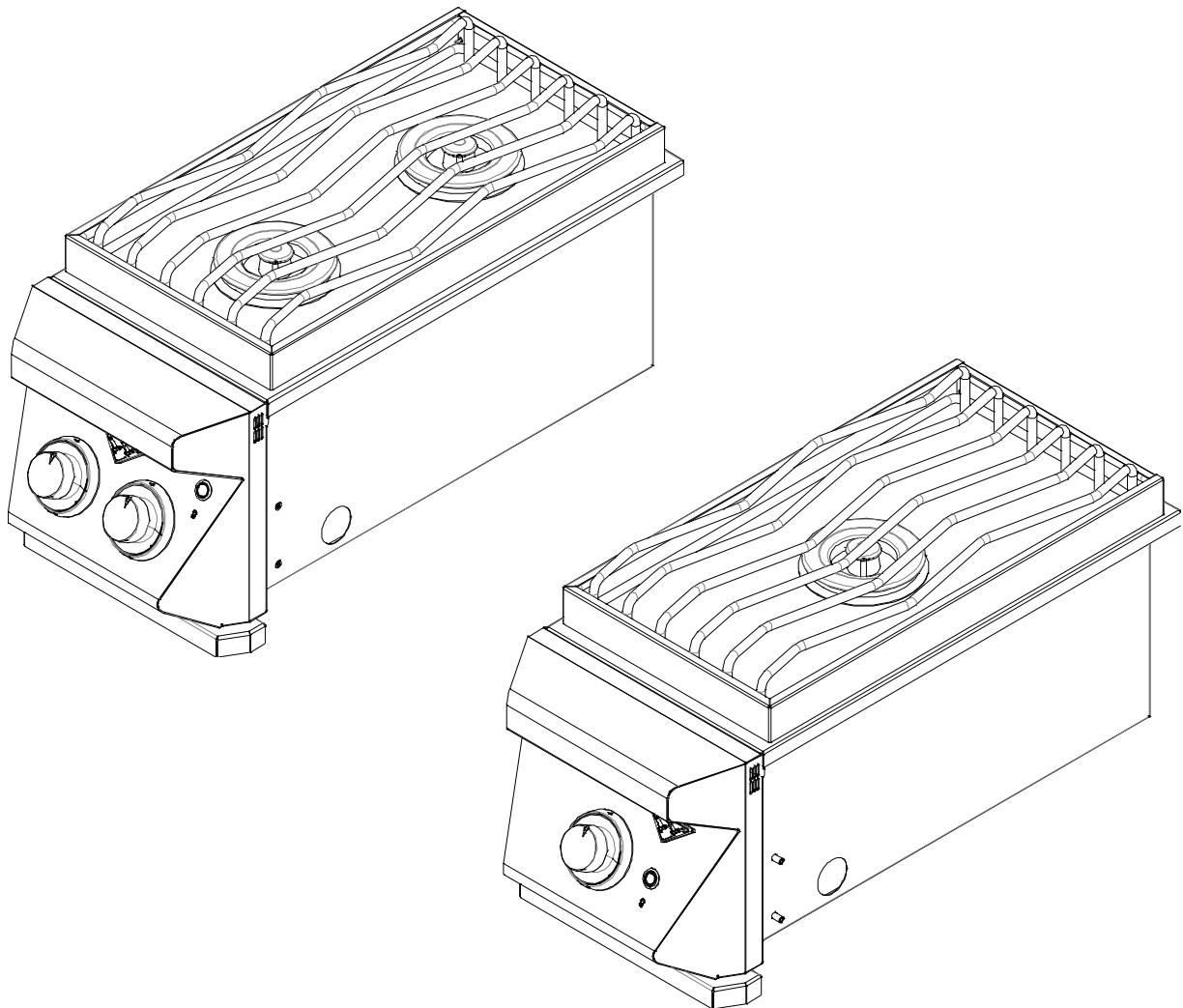

P/N: 19203G 01/19

MODELS:
TESB131-C
TESB132-C

A special message to our customers...

Congratulations on the purchase of your TWIN EAGLES grill! Our products are engineered for precision and designed for style. Each TWIN EAGLES grill is manufactured in the USA at our own state of the art facility in California.

This manual will give you easy to follow instructions for installing, operating and maintaining your grill. We recommend reading this manual before your first use to ensure safety, proper care and operation.

At TWIN EAGLES, we want you to enjoy grilling and spending time together as much as we do – making memories that linger long after the grill cools down.

Thank you and welcome!

Dante Cantal

Owner and Founder

FOR YOUR RECORDS

Please record the product information below and refer to it when contacting TWIN EAGLES. This information is found on the data nameplate, located on the bottom right hand side of the firebox near the regulator. A second label with model number and serial number is located under the right side of the control panel. Remove the drip tray to visually access the nameplate from the front of the grill.

Model #: _____

Serial #: _____

Date of Purchase: _____

Place of Purchase: _____

Type of gas: ___NG ___LP



⚠️ WARNING: CALIFORNIA PROPOSITION 65

This product can expose you to chemicals including carbon monoxide which is known to the State of California to cause cancer and reproductive harm. To minimize exposure to the by-products of the burning fuel or from combustion, always operate this unit according to the use and care manual and provide good ventilation. California law requires businesses to warn customers of potential exposure to such substances. For more information go to www.P65Warnings.ca.gov.

⚠️ AVERTISSEMENT: PROPOSITION 65 DE L'ETAT DE LA CALIFORNIE

Cet appareil peut vous exposer aux produits chimiques et au gaz monoxyde de carbone reconnue dans l'Etat de la Californie pour causer le cancer et des problemes de fertilité. Pour minimiser l'exposition de ces-sous produits combustibles ou de la combustion, utiliser toujours cet appareil en conformitee au manuel d'utilisation et d'entretien en s'assurant egalement d'une bonne ventilation. La loi de la Californie exige aux fabricants d'informer leurs clients aux risques d'exposition potentielle a de telles substances. Pour plus d'information, visiter le site www.P65Warnings.ca.gov

To the Installer:

Please read these instructions completely before installation and give this manual to the owner.

To the Owner:

Keep this manual in a safe place for future reference.

IMPORTANT SAFETY INFORMATION

WARNING! Read this manual carefully and completely before using your side burner to ensure proper operation, proper installation, proper servicing and to reduce the risk of fire, burn hazard and/ or other injury.

AVERTISSEMENT! Lire ce manuel avec soin et en entier avant l'utilisation de votre barbecue afin d'en assurer un fonctionnement, une installation et un entretien adéquats et réduire le risque d'incendie, de brûlures et d'autres blessures.

DANGER

If you smell gas:

1. Shut off gas to the appliance.
2. Extinguish any open flames.
3. If odor continues, keep away from the appliance and immediately call your gas supplier or fire department.

DANGER

S'il y a une odeur de gaz:

1. Coupez l'admission de gaz de l'appareil.
2. Éteindre toute flamme nue.
3. Si l'odeur continue, évitez l'appareil et appelez tout de suite votre fournisseur de gaz ou les pompiers.

WARNING

1. Do not store or use gasoline or other flammable vapors and liquids in the vicinity of this or any other appliance.
2. An LP cylinder not connected for use shall not be stored in the vicinity of this or any other appliance.

AVERTISSEMENT

1. Ne pas entreposer ni utiliser de l'essence ni d'autres vapeurs ou liquides inflammables dans le voisinage de l'appareil, ni de tout autre appareil.
2. Une bouteille de propane qui n'est pas raccordée en vue de son utilisation, ne doit pas être entreposée dans le voisinage de cet appareil ou de tout autre appareil.

THIS IS FOR OUTDOOR USE ONLY:

If stored indoors, detach and leave L.P. cylinder outdoors.

C'EST POUR UTILISATION À L'EXTÉRIEUR SEULEMENT:

Si l'appareil est entreposé à l'intérieur, enlever les bouteilles et les laisser à l'extérieur.

BEFORE LIGHTING

1. Read instructions before lighting.
2. Open lid during lighting.
3. If ignition does not occur in 5 seconds, turn the burner control(s) off, wait 5 minutes, and repeat the lighting procedure.

AVANT D'ALLUMER L'APPAREIL

1. Lisez les instructions avant d'allumer l'appareil.
2. Ouvrez le couvercle avant d'allumer l'appareil.
3. Si l'appareil ne s'allume pas en 5 secondes, fermez le robinet du brûleur, attendez 5 minutes, et procédez de nouveau à l'allumage.

GENERAL SAFETY REQUIREMENTS

- The installation of this appliance must conform with local codes or, in the absence of local codes, either the *National Fuel Gas Code, ANSI Z223.1/NFPA 54, Natural Gas and Propane Installation Code, CSA B149.1 or Propane Storage and Handling Code, B149.2*
- The utilization of an external electrical source requires that when installed, this outdoor cooking gas appliance must be electrically grounded in accordance with the local codes or, in the absence of local codes, with the National Electrical Code, ANSI/NFPA 70, or the Canadian Electrical Code, CSA C22.1. Keep any electrical supply cord and the fuel supply hose away from any heated surfaces.
- This outdoor cooking gas appliance shall be used only outdoors and shall not be used in a building, garage or any other enclosed area.
- This outdoor cooking gas appliance is not intended to be installed in or on recreational vehicles and /or boats.
- **Minimum clearance of 12 inches from the back and sides of the side burner to adjacent combustible construction must be maintained. This outdoor cooking gas appliance shall not be located under overhead-unprotected combustible construction.**
- Check all gas connections for leaks with soapy water solution and brush. Never use an open flame. (Reference page 5 for leak test procedure).
- Always use caution when operating the side burner in a windy area.
- Keep your side burner in an area clear and free from combustible materials, gasoline and other flammable vapors and liquids.
- DO NOT obstruct the flow of combustion and ventilation air to this appliance. Keep the ventilation openings of the cylinder enclosure free and clear from debris.
- Check flexible hoses for cuts and wear that may affect the safety before each use.
- The pressure regulator and hose assembly supplied with the Twin Eagles Side Burner must be used. Replacement pressure regulators and hose assemblies must be those specified by Twin Eagles.
- Remove all packaging materials, labels and protective plastic film. **DO NOT LEAVE UNIT IN THE SUN WITH PROTECTIVE PLASTIC FILM ON FOR A LONG PERIOD OF TIME AS IT WILL BECOME DIFFICULT TO REMOVE THE FILM.**

In Massachusetts: All gas products must be installed using a "Massachusetts" licensed plumber or gasfitter. A "T" handle type manual gas valve must be installed in the gas supply line to this appliance. This applies to permanently installed natural gas and propane installations. This does not apply to propane portable installations using a 20 pound tank.

TABLE OF CONTENTS

GAS REQUIREMENTS

- GAS SAFETY REQUIREMENT..... 1
- LP GAS HOOK-UP..... 2
- GAS REGULATOR CHECK / CONVERSION..... 3
- NATURAL GAS INSTALLATION..... 4
- LEAK TEST..... 5

LOCATING THE SIDE BURNER

- CLEARANCE TO COMBUSTIBLE CONSTRUCTION..... 6
- CLEARANCE TO NONCOMBUSTIBLE CONSTRUCTION..... 6
- CONNECTION TO GRILL/BATTERY INSTALLATION..... 6
- CUT-OUT DIMENSIONS..... 7

OPERATING INSTRUCTIONS

- HOW TO LIGHT..... 8
- MATCH LIGHTING INSTRUCTIONS..... 8

CLEANING AND MAINTENANCE

- SPIDER AND INSECT WARNING 8
- S-GRATE..... 8
- STAINLESS STEEL..... 9

REPLACEMENT PARTS

- EXPLODED VIEW..... 10
- REPLACEMENT PARTS LIST..... 11
- WIRING DIAGRAM..... 12
- TROUBLE SHOOTING GUIDE..... 13
- LIMITED PRODUCT WARRANTY..... 14
- WARRANTY REGISTRATION CARD

GAS SAFETY REQUIREMENTS

Each appliance is set and tested at the factory for the type of gas supply to be used. Identify the type of gas, either natural gas (NG) or Liquid Propane (LP) gas and make sure that the marking on the data plate (rating plate) matches the gas being supplied to the side burner. This information is found on the rating/data plate, located on the inside back of the front panel.

All gas connections should be made by a qualified technician and in accordance with local codes and ordinances. The installation must conform with local codes or, in the absence of local codes, with either the *National Fuel Gas Code, ANSI Z223.1/NFPA 54, Natural Gas and Propane Installation Code, CSA B149.1 or Propane Storage and Handling Code, B149.2*

WARNING:

ENSURE THAT THE GAS SUPPLY HOSE DOES NOT COME IN CONTACT WITH ANY HOT SURFACE OF THE SIDE BURNER.

NEVER CONNECT THE SIDE BURNER TO AN UNREGULATED GAS SUPPLY.

L.P. GAS SAFETY REQUIREMENT

The LP-gas supply cylinder must be constructed and marked in accordance with the *Specifications for LP-gas Cylinders* of the U.S. Department of Transportation (D.O.T.) or the National Standards of Canada *CAN/CSA-B339, Cylinders, Spheres and Tubes for the Transportation of Dangerous Goods, and Commission*, as applicable; and

1. Provided with a listed overfilling prevention device.
 2. Provided with a cylinder connection device compatible with the connection for outdoor cooking appliances.
- It must be provided with a shut-off valve terminating in gas tank valve outlet. It must include a collar to protect the cylinder valve. The cylinder supply system must be arranged for vapor withdrawal.
 - Do not operate the side burner indoors or in any enclosed area. If the side burner is not in use, the gas must be turned off at the supply cylinder. If the side burner is to be stored indoors, disconnect the gas supply cylinder and leave the cylinder outdoors out of reach of children and must not be stored in a building, garage or any other enclosed area.



LP GAS HOOK-UP

Install the factory-supplied hose and regulator assembly as shown. Connect the $\frac{3}{8}$ " flare end of the hose to the manifold coupling using a $\frac{3}{4}$ " open wrench. Do not apply pipe sealant to the $\frac{3}{8}$ " flare connection. Connect the regulator to the LP cylinder hand tighten it, do not use a wrench. Check for leaks using soapy water solution. (Reference page 5 for leak test procedure).

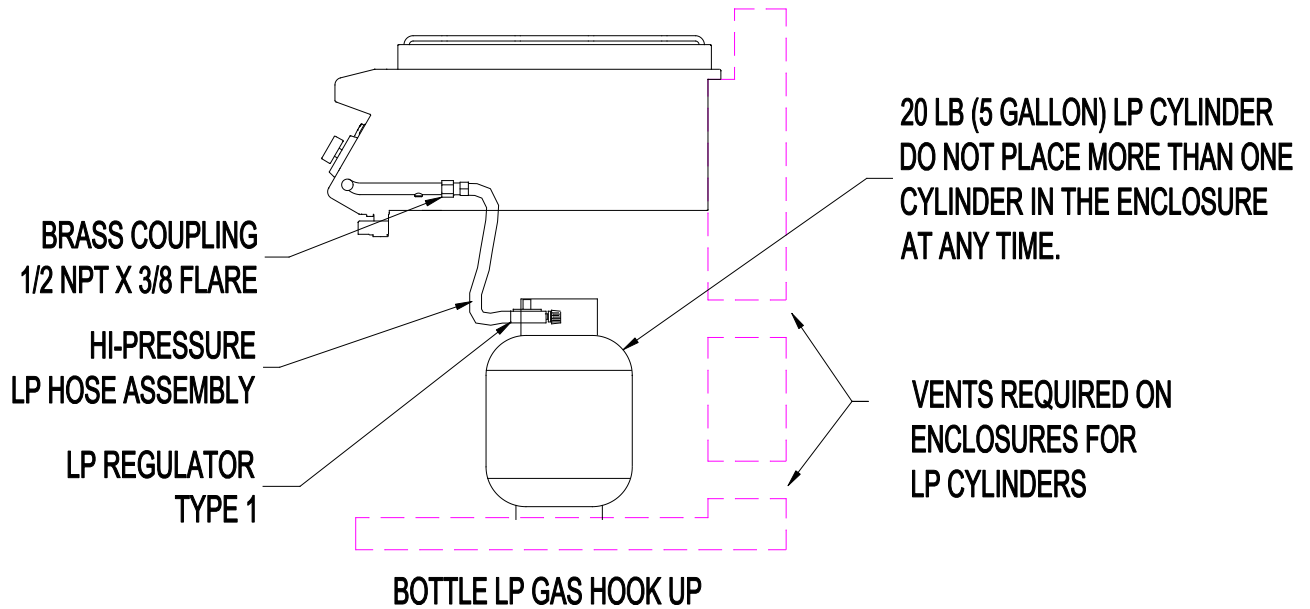

CAUTION: Provide adequate ventilation holes in the enclosure for safety purposes in the event of a gas leak.

Note: An enclosure for LP gas cylinder must be vented on the level of the cylinder valve and at floor level. The effectiveness of the opening(s) for purposes of ventilation shall be determined with the LP gas supply cylinder in place. This shall be accomplished by one of the following:

- a. One side of the enclosure shall be fully open; or
- b. For a cylinder enclosure having four sides, a top and a bottom, and intended for installation in a built-in enclosure:
 1. At least one ventilation opening shall be provided on the exposed exterior side of the enclosure located within 5 in (1.27mm) of the top of the enclosure and unobstructed. The opening(s) shall have a total free area of not less than 1 in²/lb (14.2 cm²/kg) of stored fuel capacity.
 2. At least one ventilation opening shall be provided on the exposed, exterior side of the enclosure 1 in. (25.4 mm) or less from the floor level and shall have a total free area of not less than $\frac{1}{2}$ in²/lb (7.1 cm²/kg) of stored fuel capacity. The upper edge shall be no more than 5 in (127 mm) above the floor level.
 3. Every opening shall have a minimum dimension so as to permit the entrance of 1/8 in (3.2 mm) rod.



GAS REGULATOR CHECK / CONVERSION

If the side burner is factory built for natural gas, the regulator supplied is set for 4" water column. The regulator is convertible to 10 in wc (2.49 kPa) for system LP application. Make sure that the regulator is set for the correct gas type. To check, remove the brass hex cap. You will find the conversion plastic pin attached to the cap to the underside of the cap. If the disc (1/2 in. diameter) of the pin is close to the cap, then the regulator is set for natural gas. If the disc is at the tip of the pin, away from the brass cap, the regulator is set for system LP application. To convert to natural gas, remove the plastic conversion pin and invert and replace it back in a manner such that the disc is close to the brass cap. For both natural and LP, the maximum inlet pressure is 14 in wc (3.48 kPa).

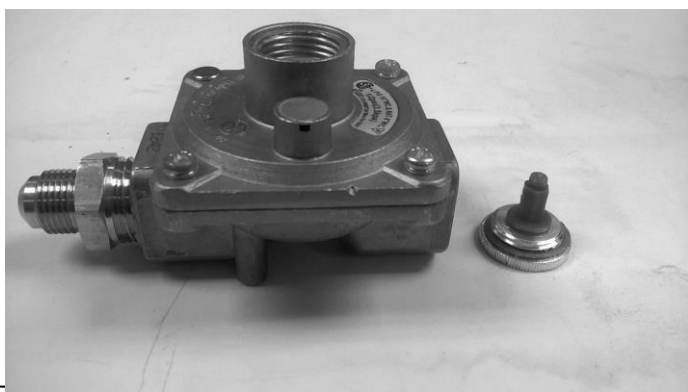

Set for NG



Set for LP

WARNING:

- DO NOT STORE SPARE LP-GAS CYLINDER UNDER OR NEAR THIS APPLIANCE.
- NEVER FILL THE CYLINDER BEYOND 80 PERCENT FULL.
- FAILURE TO DO SO MAY CAUSE FIRE, DEATH, OR SERIOUS INJURY MAY OCCUR.
- USE ONLY A 20-LBS (5 GALLON CAPACITY) GAS CYLINDER.
- DO NOT USE A DENTED OR RUSTED LP CYLINDER.
- NEVER USE A CYLINDER WITH A DAMAGED VALVE.
- ALWAYS CHECK FOR LEAKS AFTER CHANGING THE LP CYLINDER.
- THE LP PRESSURE REGULATOR AND HOSE SUPPLIED WITH THIS UNIT MUST BE USED WITHOUT ALTERATION.



NATURAL GAS INSTALLATION

A typical natural gas installation is shown below. Make sure that the factory-supplied regulator is used and installed with the arrow mark on the regulator pointing towards the side burner. Use only pipe sealants that are approved for use with natural and LP gases. An installer-supplied gas shutoff valve must be installed in an accessible location.

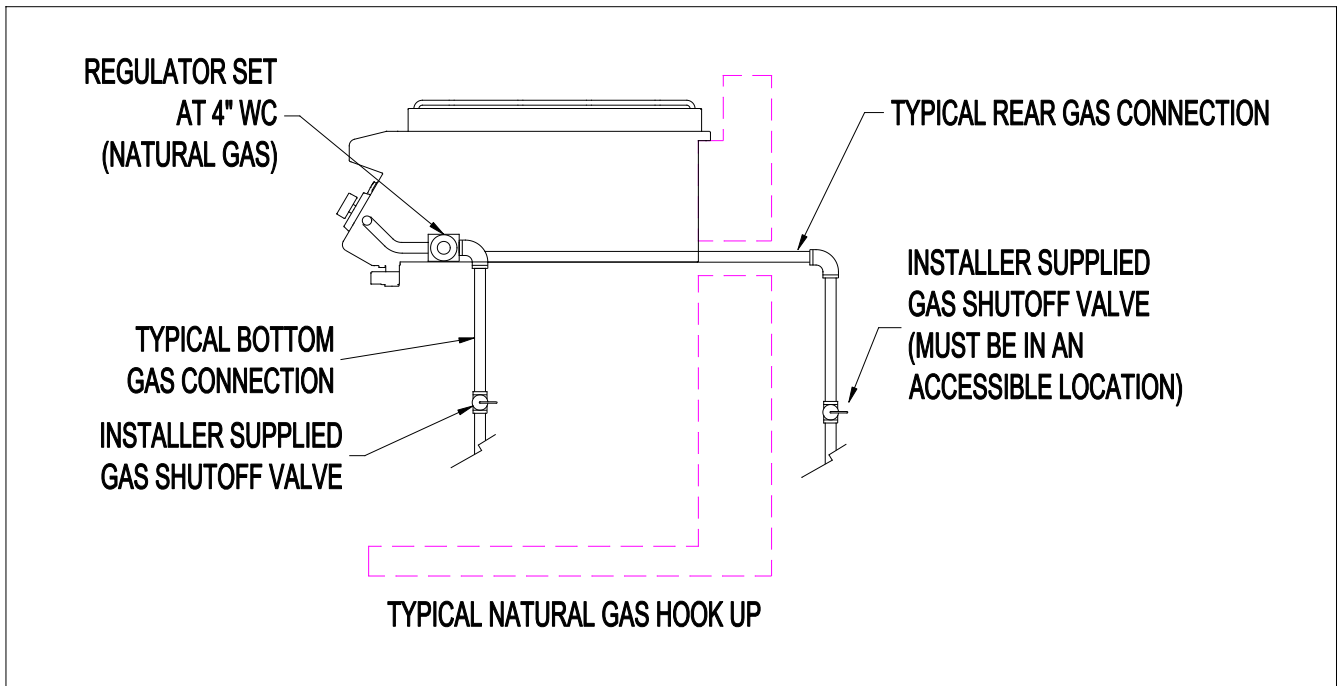

CAUTION: Provide adequate ventilation holes in the enclosure for safety purposes in the event of a gas leak.

Please note, when pressure testing, the following statements must be adhered to:

- This gas appliance and its individual shutoff valve must be disconnected from the gas supply piping system during any pressure testing of that system at the test pressures in excess of 1/2 psi (3.5 kPa).
- This appliance must be isolated from the gas supply piping system by closing its individual manual shutoff valve during any pressure testing of the gas supply piping system at test pressures equal to or less than 1/2 psi (3.5 kPa).



LEAK TEST

CAUTION BEFORE TESTING

- NEVER USE THE SIDE BURNER WITHOUT FIRST LEAK TESTING THE GAS CONNECTIONS.
- WARNING: DO NOT USE OPEN FLAME TO CHECK FOR LEAKS. USE OF AN OPEN FLAME COULD RESULT IN A FIRE, EXPLOSION AND BODILY HARM.
- DO NOT SMOKE WHILE PERFORMING THE LEAK TEST!
- To prevent fire or explosion hazard, DO NOT use or permit sources of ignition in the area while performing a leak test. Perform leak test outdoors only.
- Check to ensure that flexible hoses do not have any cuts and wear that may affect the safety before each use. Only the factory supplied hose and regulator must be used. Use only replacement regulator and hose assemblies specified by Twin Eagles.

LEAK TEST

- 1) Prepare a leak testing solution of sudsy water by mixing in a spray bottle with half liquid soap and half water.
- 2) Confirm that all control knobs are in the OFF position.
- 3) Turn the main gas valve supply ON.
- 4) Apply leak testing solution by spraying on the pipe joints, fittings, and hose.
- 5) A gas leak is detected if;
 - a) There is a faint gas smell and/or...
 - b) ...growing bubbles appear on any of the connection points and/or hose, DO NOT attempt to ignite the side burner and IMMEDIATELY turn off the gas supply valve.
- 6) When there is a gas leak, call a qualified service technician. DO NOT use the side burner until the leak is corrected.

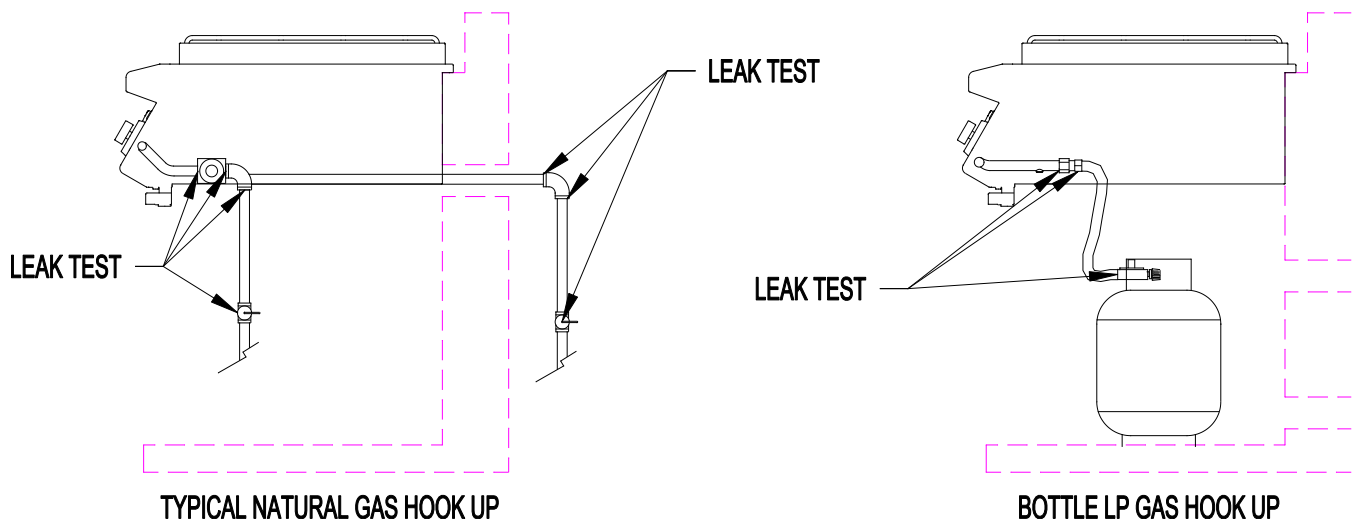

LOCATING THE SIDE BURNER

This gas appliance is designed and certified for outdoor use only. Do not locate this side burner under overhead combustible surfaces.

CAUTION should be taken when the unit is used near glass, vinyl siding or other temperature sensitive construction materials. In some cases it may be necessary to increase the clearance around the unit to avoid damage to vinyl siding. Check with the manufacturer of the siding material for details

Do not operate the side burner inside a building, garage, recreation vehicle or any enclosed area. When choosing an area, consider exposure to wind, proximity to traffic paths and length of gas supply line. Keep gas supply lines as short as possible to reduce pressure drop. Keep the side burner away from windy areas but keep the side burner in a well-ventilated area. Do not obstruct the flow of combustion and ventilation air around the side burner. The supporting edges of the side burner must be located level and flat. The counter should also be leveled.

CLEARANCE TO COMBUSTIBLE CONSTRUCTION

A minimum clearance of 12" from the sides and 12" from the back of the side burner to adjacent vertical combustible construction must be maintained.

DÉGAGEMENT DE TOUTE CONSTRUCTION COMBUSTIBLE

Il faut maintenir une distance minimum de 12 po (30.48 cm) sur les côtés et de 12 po (30.48 cm) sur l'arrière du gril par rapport aux constructions combustibles verticales adjacentes.

IMPORTANT: Prior to completing the installation into the island, connect the wire harnesses of the side burner to the grill if applicable. The location of the side burner in reference to the grill should be to the right hand side when facing the front of the grill. Installing the side burner to the left hand side of the grill is ok, but installation to the right of the grill is preferred. Both grill and side burner come with connections to the other. If wires are not long enough, an extension wire is available to make the proper connection.

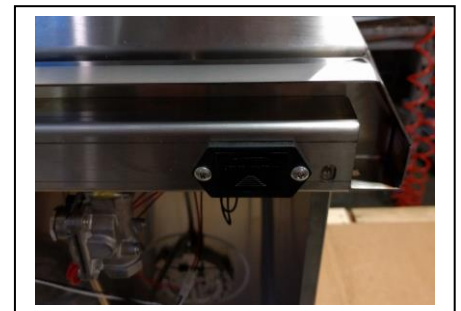
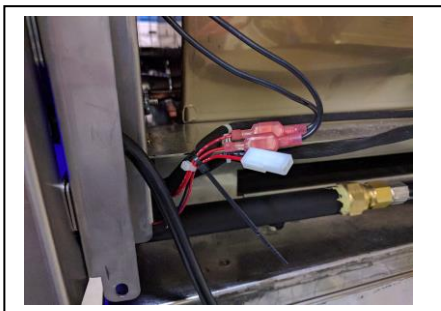

ATTENTION:

A 9-volt battery is required to be installed prior to the side burner being installed into the island. The battery is located under the false drip pan handle to the right of the bezel assembly.



CUT-OUT DIMENSIONS

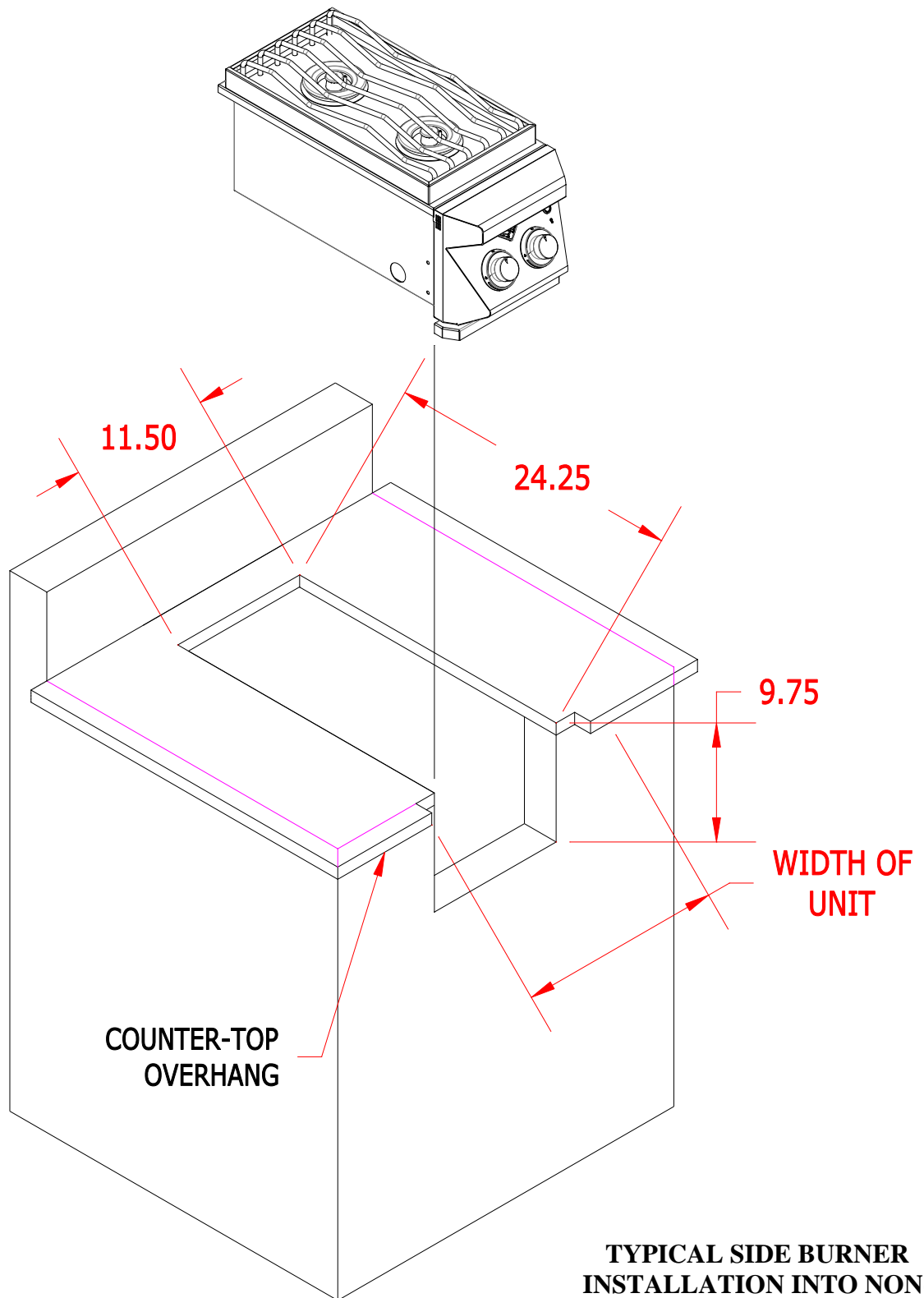

**TYPICAL SIDE BURNER
INSTALLATION INTO NON-
COMBUSTIBLE CONSTRUCTION**



OPERATING INSTRUCTIONS

HOW TO LIGHT

1. Make sure all knobs are in the "OFF" position. If using a 2-burner Side Burner the right knob is for the front burner and the left knob is for the back burner.
2. Turn "on" the gas at source. Caution: If you smell gas, shut off gas supply and call for service.
3. Before lighting, remove the side burner cover or any cooking utensils from the burner grate.
4. Push-in and turn the burner knob counterclockwise to "HI" (LARGE FLAME) position, and hold the knob in. You should hear a continuous clicking sound and see sparks being provided to the burner. (If clicking sound is weak, replace the 9V battery. See page 6).
5. If the burner does not ignite within 5 seconds, turn the burner to "OFF" and wait for five minutes. Repeat the above procedures or try the following manual lighting procedures
 - a. Hold a lit match next to the burner ports
 - b. Push and turn the burner knob counterclockwise to ignite the burner.
6. Adjust flame setting to "LOW" or "MEDIUM" or "HIGH", if desired.
7. Caution: Do not leave the side burner unattended while cooking.
8. To shutdown the burner, push and turn the burner knob clockwise to "OFF".
9. For complete shutdown, turn "off" the gas at source.

CLEANING & MAINTENANCE

SPIDER AND INSECT WARNING

Spiders and other insects can nest in the burners of this and any other grills, which causes the gas to flow from the front of the burner. This dangerous "condition" can cause a fire behind the valve panel, damaging the unit and making the unit unsafe to operate. Inspect the burners once a year or if the unit has not been used for more than one month or if any of the following conditions occur:

- 1) The smell of gas in conjunction with the burner flames appearing yellow.
- 2) The side burner does not reach temperature.
- 3) The side burner heats unevenly.
- 4) The burners make popping noises.

S-GRATE

The easiest way to clean the grates is to scrub them with a soapy cloth after cooking is completed, the flame is turned off, and the side burner has had time to cool. The grate may discolor, this is a natural reaction to the intense heat given off by the burners.



IMPORTANT Stainless Steel & General Product Care

To keep your TWIN EAGLES products free of surface corrosion and in good working order, it is important to take additional precautions under certain conditions.

If your TWIN EAGLES products are located in corrosive conditions, such as:

- A coastal environment where corrosive salty air is present
- Near a swimming pool, hot tub or water feature with exposure to corrosive pool chemicals and/or chlorinated water
- Areas where muriatic acid (hydrochloric acid) or other corrosive cleaning solutions are used to clean concrete and masonry
- Areas where corrosive masonry dust and debris are created by cutting stone or mixing cements

These conditions can create a highly corrosive environment that will cause the corrosion resistant type 304 stainless steel to develop surface oxidation, corrosion or rust.

TWIN EAGLES products have been tested in saline solutions, highly chlorinated solutions and have been tested against exposure to highly acidic foods. The test results proved the type 304 stainless steel can withstand exposure over prolonged periods of time. However, the conditions outlined above, along with neglect, can lead to surface corrosion or rust.

It is recommended that your TWIN EAGLES products be kept dry and covered when not in use. This is even more important when long-term storage is intended.

Do not allow food particles or grease to be left inside your TWIN EAGLES products. These can attract rodents, which are unsanitary and are likely to cause physical damage by chewing on the wiring, which can cause permanent damage to the electrical components.

If you are located along the coast or in the desert, wind driven sand is extremely abrasive and can pit and scratch the stainless steel. Keep your TWIN EAGLES products covered when not in use.

When routine cleaning, maintenance and awareness of the conditions outlined above, you can enjoy many years of service from your TWIN EAGLES products. In the event that surface corrosion has developed on the stainless steel, it is typically not the stainless steel that is corroding but corrosive particles that have been deposited on the surface. As a first step, we recommend "Bar Keepers Friend", available in many supermarkets and hardware stores.

TWIN EAGLES products are made of all welded stainless steel. It is non-rusting and non-magnetic. Never clean the stainless steel when it is hot. After the initial use, some areas may discolor. This is a normal discoloration caused by the intense heat given off by the burners.

Specks of grease can gather on the surface of the stainless steel and get baked-on. These can be removed by using a mild abrasive pad (like Scotch Brite) with a stainless steel cleaner. Use the mildest cleaner and always scrub in the direction of the grain. Do not use steel wool to clean the side burner.

Do not use abrasives on the polished highlights. Be extra careful when cleaning around the highlights. Metal polisher or mild chrome cleaner can be used to bring back the luster on highlights. To touch-up minor scratches in the stainless steel, sand the affected surface very lightly, with 100-dry grit emery sandpaper in the direction of the grain.



REPLACEMENT PARTS LIST

Number	Part Number	Description	TESB131-C	TESB132-C
1	S20256	Top Cover	1	1
2	S20255Y	Wind Guard	1	1
3	S13806	S-grates	1	1
4	S13309	Enameled Cap	1	2
5	S13308	Enameled Ring	1	2
6	S13307	Aluminum Bowl	1	2
7	S13306	Base with Electrode, LP	1	2
8	S13320	Base with Electrode, NG	1	2
9	S13305	Burner LP (Complete)	1	2
10	S13319	Burner, NG (Complete)	1	2
11	S26360-132Y	Front Panel (2-burner)	-	1
12	S26360-131Y	Front Panel (1-burner)	1	-
13	S13204	Twin Eagles Logo	1	1
14	S14232	Self-locking Retaining Ring	2	2
15	S16196	12V Switch	1	2
16	S13270	Light Bezel Housing Assembly	1	2
17	S13224	Lens, Light Bezel	1	2
18	S13226	Rubber Retention Ring, Light Bezel	1	2
19	S13235Y	Knob Assembly	1	2
20	S16108	Ground Wire	1	1
21	S26363	Drip Pan Handle	1	1
22	S15121	Microswitch, Valve Burner	1	2
23	S12606	1/8 Pipe Plug	2	1
24	S15149YSB	Valve Assembly	1	2
25	S12610	Bushing Reducer	1	1
26	S12710	Manifold – Side Burner	1	1
27	S26364	Drip Pan Handle Bracket	1	1
28	S16272	Battery Pack	1	1
29	S16323	Ignition Module, 2 PT	1	1
30	S15303	Regulator NG/LP	1	1
31	S15344	Regulator LP	1	1
32	S12602	Brass Coupling, 3/8 Flare x 1/2 FIP	1	1
33	S16260	72" Extension, Built-in	1	1
34	S12413	Front Gas Tubing	-	1
35	S12414	Back Gas Tubing	-	1
36	S12415	Single Burner Gas Tubing	1	-
37	S12609	Nut, Brass + Sleeve, 1/8 FIP x 5/16 CC	1	2
NON-SHOWN PARTS				
	S13313	Center Orifice,# 82, NG	1	2
	S13314	Outside Orifice, #175, NG	1	2
	S13317	Center Orifice, #50, LP	1	2
	S13318	Outside Orifice, #100, LP	1	2
	S16402	Wire Harness	1	1
	S16006	Wire Loop 8"	-	1
	S16339	Wire Harness, Module	1	1



WIRING DIAGRAM

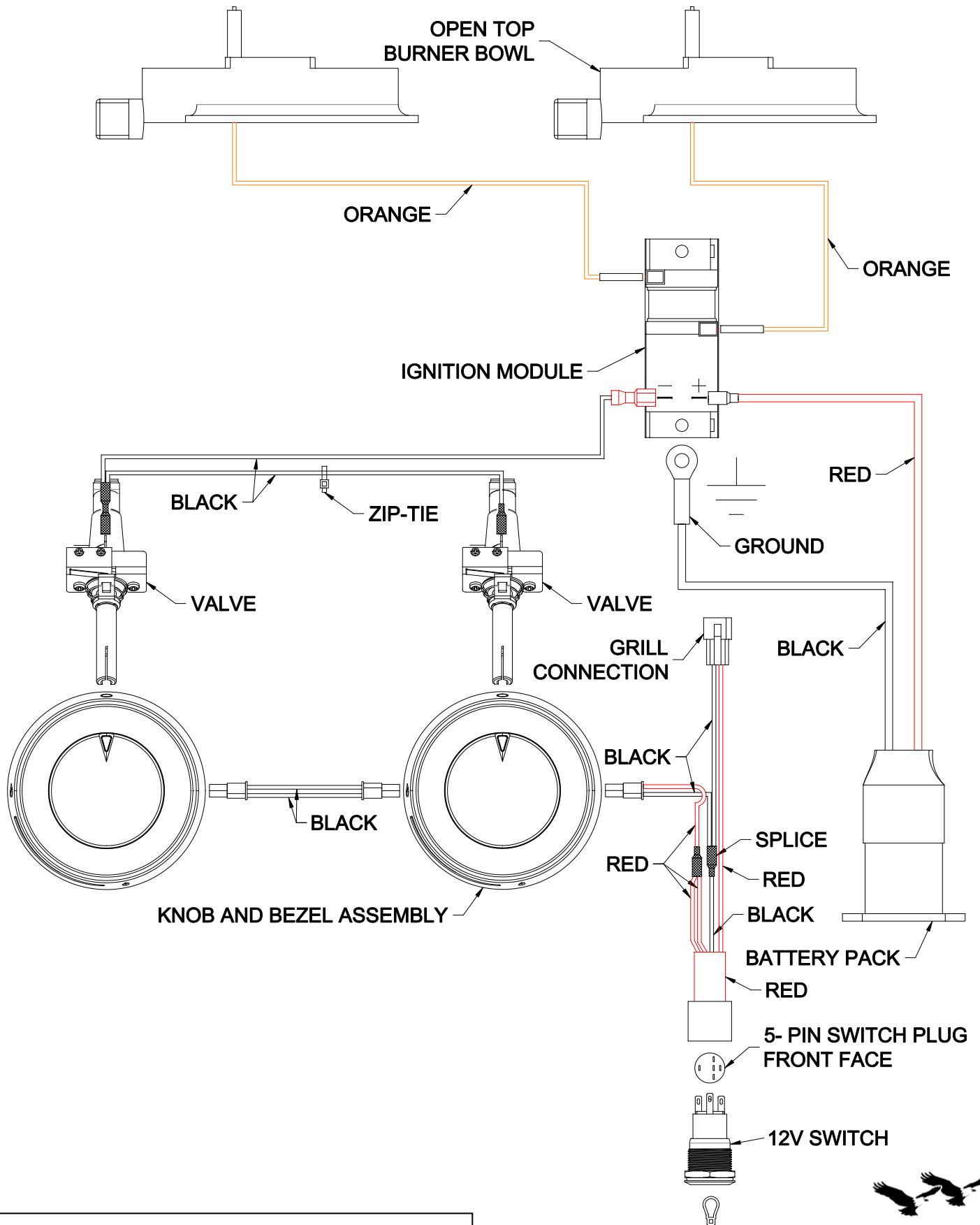

TESB132/132F-C WIRING DIAGRAM SHOWN



TROUBLE SHOOTING GUIDE

BEFORE CALLING FOR SERVICE:

If your Twin Eagles Side Burner does not function properly, use the following trouble shooting guide before contacting your dealer for service. The troubleshooting guide may save you the cost of a service call and the inconvenience of being without your Side Burner. **IMPORTANT:** before any troubleshooting, make sure your Twin Eagles product is allowed adequate time to cool.

PROBLEM	WHAT TO DO
Side Burner will not light.	<ol style="list-style-type: none"> 1. Push in the knob and verify that the igniter sparks. 2. If the igniter does not spark verify proper power supply. 9V. <ol style="list-style-type: none"> a. Purge the line of any trapped air. b. Check if you can match-light the burner. c. Check to see that the other burners operate (if you own a 2-burner Side Burner). <p>NOTE: It is normal to hear a popping sound when the burners are first turned ON.</p>
Burner flame is yellow and gas odor can be smelled.	<ol style="list-style-type: none"> 1. Check the burner ring(s) for obstruction...ex. Spiders, insects, etc. 2. Check any source of gas leak.
Low heat generated with knob in HI position.	<ol style="list-style-type: none"> 1. Check if the problem is isolated to only one burner. If it appears so, clean the orifice and burner, clearing ports of any obstruction. 2. Check for any bent or kinked fuel hose. 3. Check for proper gas supply and pressure. 4. If using LP gas, check for empty tank.
Too much heat.	<ol style="list-style-type: none"> 1. Check for damaged orifice or no orifice. 2. Check for unauthorized regulator adjustment.
Excessive flare-up.	<ol style="list-style-type: none"> 1. Check if the enamel rings are dirty. Clean if necessary.
Burner blows out	<ol style="list-style-type: none"> 1. Check for any burner defect. 2. Check for proper burner installation. 3. Check if fuel mixture is too lean. 4. Check if gas supply is sufficient. 5. Check if LP tank is empty. 6. Check if the Side Burner location is subject to high winds.
Bezel light / Switch light will not turn ON.	<ol style="list-style-type: none"> 1. Check if the unit is plugged into proper voltage (GFCI 120V). 2. Replacement of the Bezel Assembly may be required.
Spark igniter will not turn ON.	<ol style="list-style-type: none"> 1. Check if the unit is plugged into proper voltage (9V). 2. Check if microswitch makes contact.





TWIN EAGLES

U S A

INNOVATION AND INSPIRATION ON FIRE™

TWIN EAGLES WARRANTY

LIMITED TWO YEAR WARRANTY: Twin Eagles warrants the Side Burner to be free from defects in materials and workmanship under normal residential use for a period of two years from the original date of purchase. The actual part will be repaired or replaced, free of charge, with the owner paying for all other costs including labor, shipping and handling.

ONE-YEAR FULL WARRANTY: Twin Eagles warrants the Side Burner and all other components to be free from defects in materials and workmanship under normal residential use for a period of one year from the original date of purchase. Twin Eagles will repair or replace parts found to be defective at no cost to the original purchaser. Warranty service must be performed by a Twin Eagles authorized representative during normal business hours.

NINETY (90) DAY RESIDENTIAL PLUS WARRANTY: This warranty applies to applications where use of the product extends beyond normal residential use such as bed and breakfast inn and private clubs. The actual part will be repaired or replaced, free of charge, with the owner paying for all other costs including labor, shipping and handling. This warranty excludes all commercial locations such as restaurants and food service locations.

WARRANTY LIMITATIONS & EXCLUSIONS

This warranty shall apply only to the products purchased and located in the continental United States and Canada. The warranty coverage begins on the original date of purchase and proof of date of purchase is required. To activate the warranty, we require that you send in the attached warranty registration card. This warranty applies only to the original owner and may not be transferred.

This warranty excludes discoloration, surface scratches, weather and atmospheric related staining, and minor surface rust and oxidation which are normal conditions and are to be expected with any outdoor product. This warranty does not apply to damages resulting from negligence, alteration, misuse, abuse, accident, natural disaster, loss of electrical power to the product for any reason, improper installation or improper operation, unauthorized adjustments or calibrations, dings, dents, scratches, or damages due to harsh cleaning chemicals. This warranty does not apply to commercial use, or to products with altered or removed serial numbers. Display models are generally sold "as is" and are subject to the following warranty exclusions: missing components, scratches, dents and other exterior or cosmetic damages, electrical, gas and ignition system. Twin Eagles shall not be liable for incidental, consequential, special or contingent damages resulting from its breach of this written warranty or any implied warranty.

WARRANTY SERVICE & REPLACEMENT PARTS: Call your authorized selling dealer or call Twin Eagles directly at **800-789-2206**. Be prepared to furnish the following information: Purchaser's name, model and serial number of the side burner, date of purchase and the accurate description of the problem. Twin Eagles will not pay for service calls for correcting an installation problem. Owner shall be responsible for proper installation, providing normal care and maintenance, providing proof of purchase upon request and making the side burner accessible for service. In the event of any warranty replacement, all removal, replacement, installation and shipping costs are the responsibility of the owner.

Some states do not allow limitations on how long an implied warranty lasts, or the exclusions of or limitations on consequential damages. This warranty gives you specific legal rights and you may have other rights, which vary from state to state.



THIS PAGE IS INTENTIONALLY LEFT BLANK



HOW TO OBTAIN SERVICE

For service, please contact your TWIN EAGLES dealer or call TWIN EAGLES direct at (800) 789-2206 or (562) 802-3488 or fax (562) 802-3391

Mailing address:
Twin Eagles, Inc.
13259 East 166th Street
Cerritos, CA 90703

Visit us at www.twineaglesgrills.com

Please provide:

- Model number
- Serial Number
- Date of Purchase
- A description of the problem

Cut
Here



Warranty Registration

Customer Name

Model #

Address

Serial #

City, State

Date Purchased

Zip

Dealer's Name

Phone #

Dealer's Address

e-mail:

This Warranty Registration card must be returned within thirty days of purchased to properly activate your warranty. This information is for our internal use only.

Or you may register online at <https://www.twineaglesgrills.com/resources/warranty-registration>

Cut
Here

Place
Postage
Here



INNOVATION AND INSPIRATION ON FIRE™

Customer Service
ATTN: Warranty Department
13259 East 166th Street
Cerritos, CA 90703
Fax no. (562) 802-3391