

This Owner's Manual is provided and hosted by [Appliance Factory Parts](http://www.appliancefactoryparts.com).



Napoleon GVFT8P Owner's Manual

[Shop genuine replacement parts for Napoleon GVFT8P](#)

10.0 REPLACEMENTS

COMPONENTS

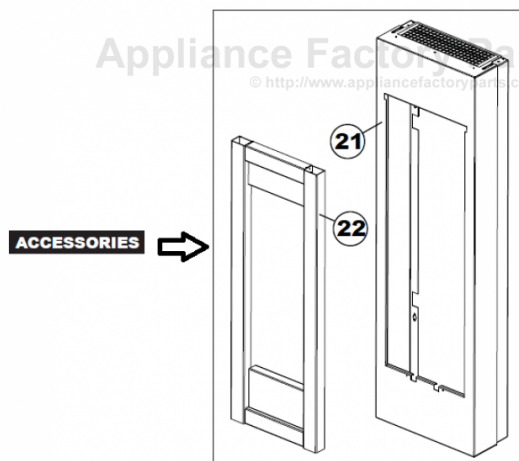
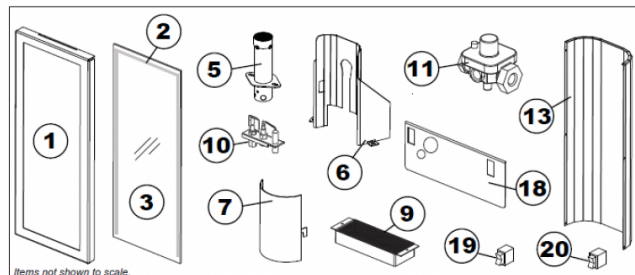

[Find Your Napoleon Fireplace Parts - Select From 171 Models](#)

----- Manual continues below -----

INSTALLER: LEAVE THIS MANUAL WITH THE APPLIANCE.
CONSUMER: RETAIN THIS MANUAL FOR FUTURE REFERENCE.
NEVER LEAVE CHILDREN OR OTHER AT RISK INDIVIDUALS ALONE WITH THE APPLIANCE.



INSTALLATION AND OPERATING INSTRUCTIONS

CERTIFIED UNDER AMERICAN NATIONAL STANDARDS, ANSI Z21.11.2B, VOLUME II FOR UNVENTED ROOM HEATERS.

CERTIFIED FOR THE UNITED STATES USING ANSI METHODS.

SAFETY INFORMATION

WARNING

If the information in these instructions are not followed exactly, a fire or explosion may result causing property damage, personal injury or loss of life.

- Do not store or use gasoline or other flammable vapors and liquids in the vicinity of this or any other appliance.
- WHAT TO DO IF YOU SMELL GAS:
 - Do not try to light any appliance.
 - Do not touch any electrical switch; do not use any phone in your building.
 - Immediately call your gas supplier from a neighbour's phone. Follow the gas supplier's instructions.
 - If you cannot reach your gas supplier, call the fire department.
- Installation and service must be performed by a qualified installer, service agency or the supplier.
- This is an unvented gas-fired heater that uses air (oxygen) from the room in which it is installed. Provisions for adequate combustion and ventilation air must be provided. Refer to section "COMBUSTION AND VENTILATION AIR PROVISIONS".

This appliance may be installed in an aftermarket, permanently located, manufactured (mobile) home, where not prohibited by local codes. This appliance is only for use with the type of gas indicated on the rating plate. This appliance is not convertible for use with other gases.



GVFT8N

NATURAL GAS

GVFT8P

PROPANE

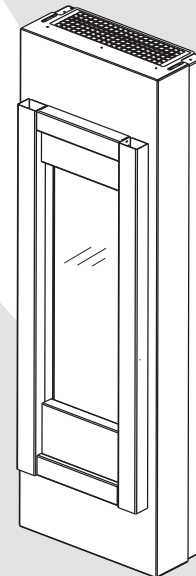

WARNING

HOT GLASS WILL CAUSE BURNS.

DO NOT TOUCH GLASS UNTIL COOLED.

NEVER ALLOW CHILDREN TO TOUCH GLASS.



Wolf Steel Ltd., 24 Napoleon Rd., Barrie, ON, L4M 0G8 Canada /
103 Miller Drive, Crittenden, Kentucky, USA, 41030

Phone (705)721-1212 • Fax (705)722-6031 • www.napoleonfireplaces.com • ask@napoleonproducts.com

TABLE OF CONTENTS

1.0	INSTALLATION OVERVIEW	3
2.0	INTRODUCTION	4
2.1	DIMENSIONS	5
2.2	GENERAL INSTRUCTIONS	5
2.3	GENERAL INFORMATION	7
2.4	RATING PLATE INFORMATION	7
3.0	INSTALLATION	8
3.1	COMBUSTION AND VENTILATION AIR PROVISIONS	8
3.2	DETERMINING CONFINED OR UNCONFINED SPACE	8
3.3	GAS INSTALLATION	10
3.4	GAS PRESSURE	11
4.0	FRAMING	12
4.1	CLEARANCE TO COMBUSTIBLES	12
5.0	FINISHING	13
5.1	MOUNTING CABINET INSTALLATION	13
5.2	DOOR REMOVAL	14
5.3	FRAME INSTALLATION	15
5.4	LOGO PLACEMENT	16
5.5	GLASS MEDIA INSTALLATION	16
5.6	LK8 LIGHT INSTALLATION (OPTIONAL)	17
6.0	ELECTRICAL INFORMATION	18
7.0	OPERATION	19
8.0	ADJUSTMENTS	20
8.1	VENTURI ADJUSTMENT	20
8.2	FLAME CHARACTERISTICS	20
9.0	MAINTENANCE	21
9.1	CLEANING	21
9.2	CARE OF GLASS	22
9.3	DOOR GLASS REPLACEMENT	22
10.0	REPLACEMENTS	23
11.0	TROUBLE SHOOTING	25
12.0	WARRANTY	26
13.0	SERVICE HISTORY	27

NOTE: Changes, other than editorial, are denoted by a line in the margin.

1.0 INSTALLATION OVERVIEW

Mounting cabinet, see
"MOUNTING CABINET
INSTALLATION" section.

Door, see "DOOR REMOVAL"
section.

Logo, see "LOGO PLACEMENT"
section.

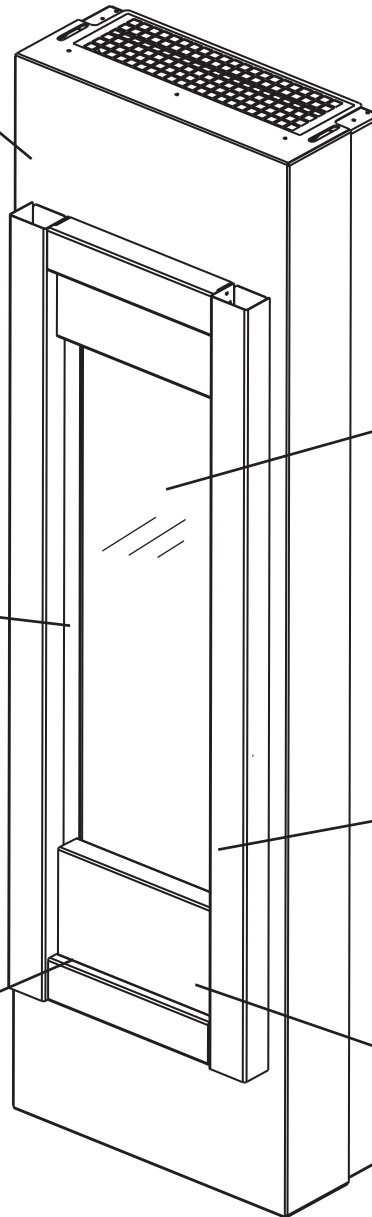

Glass, see "GLASS
REMOVAL" section.

Frame, see "FRAME
INSTALLATION" section.

Rating Plate, see
"RATING PLATE
INFORMATION" section.

⚠ WARNING: This product can expose you to chemicals including lead and lead compounds, which are known to the State of California to cause cancer, and chemicals including carbon monoxide, which are known to the State of California to cause birth defects or other reproductive harm. For more information, go to www.P65Warnings.ca.gov.

2.0 INTRODUCTION

WARNING

- **THIS APPLIANCE IS HOT WHEN OPERATED AND CAN CAUSE SEVERE BURNS IF CONTACTED.**
- **ANY CHANGES TO THIS APPLIANCE OR ITS CONTROLS CAN BE DANGEROUS AND IS PROHIBITED.**
- Under no circumstances should this appliance be modified.
- Do not operate appliance before reading and understanding operating instructions. Failure to operate appliance according to operating instructions could cause fire or injury.
- Risk of burns. The appliance should be turned off and cooled before servicing.
- Do not install damaged, incomplete or substitute components.
- Risk of cuts and abrasions. Wear protective gloves and safety glasses during installation. Sheet metal edges may be sharp.
- Provide adequate ventilation and combustion air. Provide adequate accessibility clearance for servicing and operating the appliance. Never obstruct the front opening of the appliance.
- If the appliance shuts off, do not re-light until you provide fresh air. If appliance keeps shutting off, have it serviced. Keep burner and control compartment clean.
- Do not burn wood or other materials in this appliance.
- Children and adults should be alerted to the hazards of high surface temperature and should stay away to avoid burns or clothing ignition.
- Young children should be carefully supervised when they are in the same room as the appliance. Toddlers, young children and others may be susceptible to accidental contact burns. A physical barrier is recommended if there are at risk individuals in the house. To restrict access to an appliance, install an adjustable safety gate to keep toddlers, young children and other at risk individuals out of the room and away from hot surfaces.
- Due to high temperatures, the appliance should be located out of traffic and away from furniture and draperies.
- Ensure you have incorporated adequate safety measures to protect infants/toddlers from touching hot surfaces.
- Clothing or other flammable material should not be placed on or near the appliance.
- Check with your local hearth specialty dealer for safety screens and hearth guards to protect children from hot surfaces. These screens and guards must be fastened to the floor.
- Any safety screen or guard removed for servicing must be replaced prior to operating the appliance.
- It is imperative that the control compartments, burners and circulating blower and its passageway in the appliance are kept clean. The appliance should be inspected before use and at least annually by a qualified service person. More frequent cleaning may be required due to excessive lint from carpeting, bedding material, etc. The appliance area must be kept clear and free from combustible materials, gasoline and other flammable vapours and liquids.
- Furniture or other objects must be kept a minimum of 4 feet away from the front of the appliance.
- Do not use this appliance if any part has been under water. Immediately call a qualified service technician to inspect the appliance and to replace any part of the control system and any gas control which has been under water.
- Do not allow fans to blow directly into the appliance. Avoid any drafts that alter burner flame patterns.
- Do not use a blower insert, heat exchanger insert or other accessory not approved for use with this appliance.
- Carbon or soot should not occur in a vent free appliance as it can distribute into the living area of your home. If you notice any signs of carbon or soot, immediately turn off your appliance and arrange to have it serviced by a qualified technician before operating it again.
- Keep the packaging material out of reach of children and dispose of the material in a safe manner. As with all plastic bags, these are not toys and should be kept away from children and infants.
- As with any combustion appliance, we recommend having your appliance regularly inspected and serviced as well as having a Carbon Monoxide Detector installed in the same area to defend you and your family against Carbon Monoxide.
- If equipped, the screen must be in place (closed) when the appliance is in operation.
- Ensure clearances to combustibles are maintained when building a mantel or shelves above the appliance. Elevated temperatures on the wall or in the air above the appliance can cause melting, discolouration or damage to decorations, a T.V. or other electronic components.

3.4B

2.1 DIMENSIONS

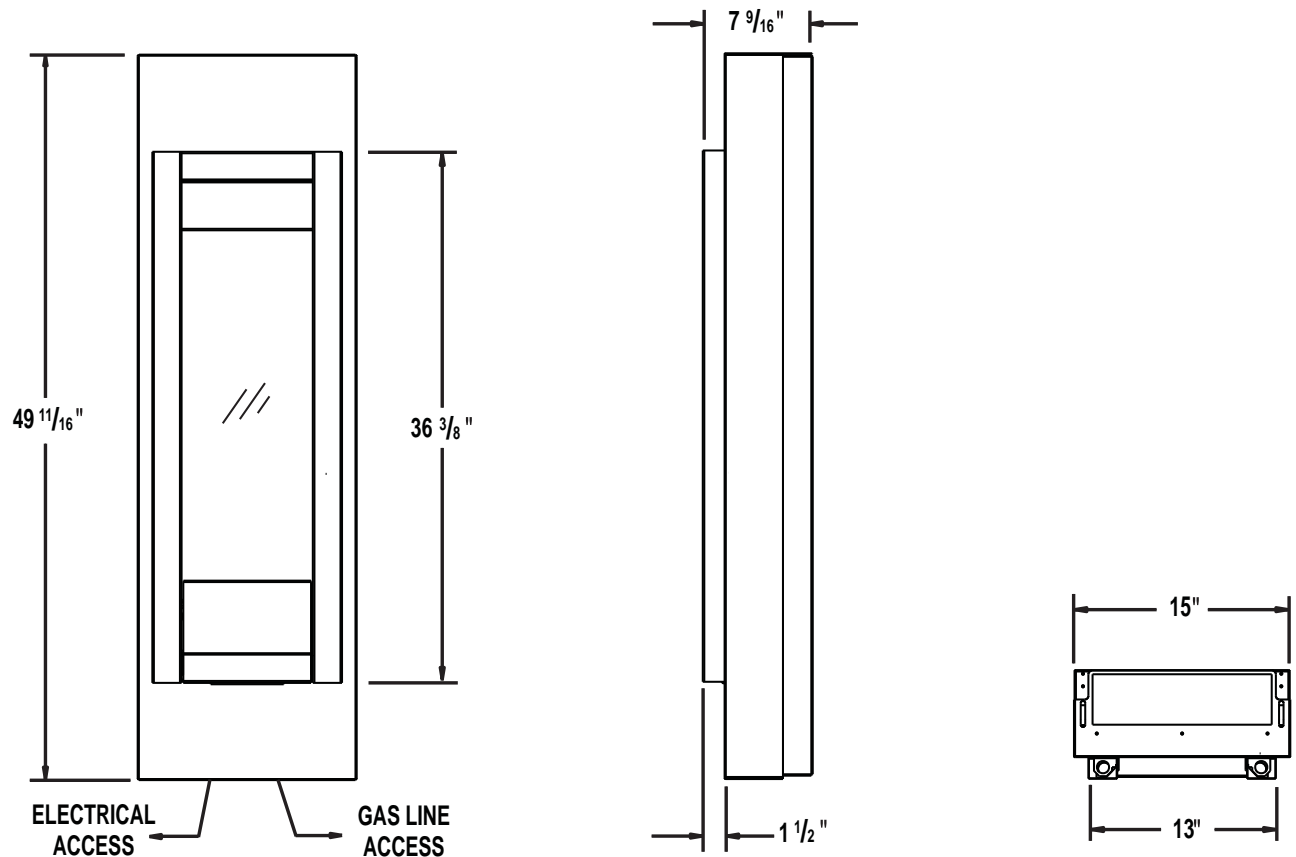

2.2 GENERAL INSTRUCTIONS

! WARNING
<p>CARBON MONOXIDE POISONING MAY LEAD TO DEATH EARLY SIGNS OF CARBON MONOXIDE POISONING RESEMBLE THE FLU, WITH HEADACHE, DIZZINESS AND/OR NAUSEA. IF YOU HAVE THESE SIGNS, THE HEATER MAY NOT BE WORKING PROPERLY. GET FRESH AIR AT ONCE! HAVE HEATER SERVICED. SOME PEOPLE---PREGNANT WOMEN, PERSONS WITH HEART OR LUNG DISEASE, ANEMIA, THOSE UNDER THE INFLUENCE OF ALCOHOL, THOSE AT HIGH ALTITUDES--- ARE MORE AFFECTED BY CARBON MONOXIDE THAN OTHERS.</p>
<p>IT IS RECOMMENDED THAT PERSONS WITH RESPIRATORY PROBLEMS NOT USE VENT FREE APPLIANCES</p>
<p>THE HEATER IS ONLY FOR USE WITH THE TYPE OF GAS INDICATED ON THE RATING PLATE. THIS HEATER IS NOT CONVERTIBLE FOR USE WITH OTHER GASES.</p>
<p>OBJECTS PLACED IN FRONT OF THE HEATER SHOULD BE KEPT A MINIMUM OF 48" AWAY FROM THE GLASS FRONT FACES OF THE HEATER.</p>
<p>USE ONLY WOLF STEEL APPROVED OPTIONAL ACCESSORIES AND REPLACEMENT PARTS WITH THIS APPLIANCE. USING NON-LISTED ACCESSORIES AND REPLACEMENT PARTS (BLOWERS, LOUVRES, TRIMS, GAS COMPONENTS, VENT COMPONENTS, ETC.) COULD RESULT IN A SAFETY HAZARD AND WILL VOID THE LIMITED LIFETIME WARRANTY.</p>
<p>DO NOT OPERATE WITHOUT CERAMIC CATALYST IN PLACE.</p>

This gas appliance should be installed and serviced by a qualified installer to conform with local codes. Installation practices vary from region to region and it is important to know the specifics that apply to your area, for example: in Massachusetts State:

- The appliance off valve must be a "T" handle gas cock.
- The flexible connector must not be longer than 36".
- The appliance is not approved for installation in a bedroom or bathroom unless the appliance is a direct vent sealed combustion product.
- A carbon monoxide detector is required in all rooms containing gas fired appliances.
- **WARNING:** This product must be installed by a licensed plumber or gas fitter when installed within the commonwealth of Massachusetts.
- Un-vented room appliance shall be installed in accordance with 527 CMR 30.00 and 248 CMR 3.00 through 7.00.
- Sellers of un-vented propane or natural gas-fired space / room appliances shall provide to each purchaser a copy of 527 CMR 30.00 upon the sale of the appliance from http://www.napoleonfireplaces.com/Webshare/installation_manuals/mass_requirements.pdf

In absence of local codes, install the appliance to the current National Fuel Gas Code, ANSI Z223.1 Installation Code which can be obtained from:

American National Standards Institute Inc.
1430 Broadway
New York, NY 10018

or

National Fire Protection Association Inc.
Batterymarch Park
Quincy, MA 02269

The appliance and its individual shutoff valve must be disconnected from the gas supply piping system during any pressure testing of that system at test pressures in excess of 1/2 psig (3.5 kPa). The appliance must be isolated from the gas supply piping system by closing its individual manual shutoff valve during any pressure testing of the gas supply piping system at test pressures equal to or less than 1/2 psig (3.5 kPa). When installed with a blower the junction box must be electrically connected and grounded in accordance with local codes. In the absence of local codes, use the current ANSI / NFPA 70 National Electric Code. In the case where the blower is equipped with a power cord it must be connected into a properly grounded receptacle. The grounding prong must not be removed from the cord plug.

As long as the required clearance to combustibles is maintained, the most desirable and beneficial location for the appliance is in the center of a building, thereby allowing the most efficient use of the heat created. The location of windows, doors and the traffic flow in the room where the appliance is to be located should be considered. If possible, you should choose a location where the vent will pass through the house without cutting a floor or roof joist.

**NATIONAL
FIREPLACE
INSTITUTE**



CERTIFIED

www.nficertified.org

We suggest that our gas hearth products be installed and serviced by professionals who are certified in the U.S. by the National Fireplace Institute® (NFI) as NFI Gas Specialists

4.6A

2.3 GENERAL INFORMATION

FOR YOUR SATISFACTION, THIS APPLIANCE HAS BEEN TEST-FIRED TO ENSURE ITS OPERATION AND QUALITY!

RATES AND EFFICIENCIES		
	NATURAL GAS	PROPANE
Altitude	0 - 2,000*	0 - 2,000*
Maximum input	6,000	6,000
Minimum Inlet Gas Supply Pressure	4.5" Water Column	11" Water Column
Maximum Inlet Gas Supply Pressure	7" Water Column	13" Water Column
Manifold Pressure Under Flow Conditions	3.5" Water Column	10" Water Column

* When the appliance is installed at elevations above 2,000ft and in the absence of specific recommendations from the local authority having jurisdiction, the certified altitude input rating shall be reduced at the rate of 4% for each additional 1,000ft.

This appliance is only for use with the type of gas indicated on the rating plate. For rating plate location, see either "INSTALLATION OVERVIEW" or "RATING PLATE INFORMATION" section. This appliance is not convertible for use with other gases, unless a certified kit is used.

Expansion / contraction noises during heating up and cooling down cycles are normal and are to be expected.

2.4 RATING PLATE INFORMATION

The rating label is located under the control panel and is chained to the appliance. **DO NOT REMOVE.**

This illustration is for reference only. Refer to the rating plate on the appliance for accurate information.

 Intertek <input type="checkbox"/> 9700539 (WSL) <input type="checkbox"/> 4001657 (NGZ) <input type="checkbox"/> 4001658 (NAC) <input type="checkbox"/> 4001659 (WUSA)	CERTIFIED UNDER : ANSI Z21.11.2a-2008 VOLUME II, UNVENTED ROOM HEATER THIS APPLIANCE MAY BE INSTALLED IN AN AFTERMARKET, PERMANENTLY LOCATED, MANUFACTURED (MOBILE) HOME, WHERE NOT PROHIBITED BY LOCAL CODES. THIS APPLIANCE IS ONLY FOR USE WITH THE TYPE OF GAS INDICATED ON THE RATING PLATE. THIS APPLIANCE IS NOT FIELD CONVERTIBLE FOR USE WITH OTHER GASES. THIS IS A GAS-FIRED UNVENTED ROOM HEATER THAT REQUIRES ADEQUATE COMBUSTION AND VENTILATION AIR.	
	MODEL GVFT8N <input type="checkbox"/> (NATURAL GAS) 0-2000FT (0-1370m) 6,000 BTU/h	MODEL <input type="checkbox"/> GVFT8P (PROPANE) 0-2000FT (0-1370m) 6,000 BTU/h
	MANIFOLD PRESSURE: 3.5" WATER COLUMN MINIMUM SUPPLY PRESSURE: 4.5" WATER COLUMN MAXIMUM SUPPLY PRESSURE: 7.0" WATER COLUMN CONTROL: COPRECI T15 OXY PROTECTOR SIT: #9099	MANIFOLD PRESSURE: 10" WATER COLUMN MINIMUM SUPPLY PRESSURE: 11" WATER COLUMN MAXIMUM SUPPLY PRESSURE: 13" WATER COLUMN CONTROL: COPRECI T15 OXY PROTECTOR SIT: #9266
	WARNING: DO NOT ADD ANY MATERIAL TO THE APPLIANCE, WHICH WILL COME IN CONTACT WITH THE FLAME. DO NOT USE ACCESSORIES NOT APPROVED FOR USE WITH THIS APPLIANCE. IMPROPER INSTALLATION, ADJUSTMENT, ALTERATION, SERVICE OR MAINTAINANCE CAN CAUSE PROPERTY DAMAGE, PERSONAL INJURY OR LOSS OF LIFE. REFER TO THE OWNER'S INFORMATION MANUAL PROVIDED WITH THIS APPLIANCE. INSTALLATION AND SERVICE MUST BE PERFORMED BY A QUALIFIED INSTALLER, SERVICE AGENCY OR THE GAS SUPPLIER.	
MINIMUM CLEARANCES TO COMBUSTIBLE MATERIALS TOP 18" FLOOR 8" SIDES 1" BACK 0" TOP, SIDES & BACK AS PER ABOVE. FOR FINISHING MATERIAL, SEE OWNERS MANUAL.		
ELECTRICAL RATING: 115V 0.82AMP 60HZ	WOLF STEEL LTD. 24 NAPOLEON ROAD, BARRIE, ONTARIO L4M 0G8 CANADA SERIAL NUMBER: GVFT8 XXXXXXXXXX W385-0480 / C	

3.0 INSTALLATION

3.1 COMBUSTION AND VENTILATION AIR PROVISIONS

This appliance shall not be installed in a confined space or unusually tight construction unless provisions are provided for adequate combustion and ventilation air.

The National Fuel Gas Code, ANSI Z223.1 / NFPA 54 defines a confined space as a space whose volume is less than 50 cubic feet per 1,000 Btu per hour (4.8 m³ per kw) of the aggregate input rating of all appliances installed in that space and an unconfined space as a space whose volume is not less than 50 cubic feet per 1,000 Btu per hour (4.8 m³ per kw) of the aggregate input rating of all appliances installed in that space. Rooms communicating directly with the space in which the appliances are installed, through openings not furnished with doors are considered a part of the unconfined space.

17.1A

The GVFT8 is rated at 6,000 BTUs per hour for natural gas and propane and therefore requires a minimum unconfined space of 300 cubic feet.

3.2 DETERMINING CONFINED OR UNCONFINED SPACE

To determine the volume of the room where the appliance is to be installed, multiply the width x the length x the ceiling height of that room measured in feet. If any adjoining rooms are connected by grilles or openings such as kitchen pass-throughs, etc., the volume of those rooms may be added to the total.

Multiply the room volume by 1000 and divide this amount by 50 to determine the maximum BTU/hr that the space can support with adequate combustion and ventilation air.

Add the Btu/hr of all fuel burning appliances located within the space such as gas furnace, gas water appliance, etc. Do not include direct vent gas appliances which draw their input and output air from and to the outdoors.

WARNING

IF THE AREA IN WHICH THE APPLIANCE MAY BE OPERATED IS SMALLER THAN THAT DEFINED AS AN UNCONFINED SPACE OR IF THE BUILDING IS OF UNUSUALLY TIGHT CONSTRUCTION, PROVIDE ADEQUATE COMBUSTION AND VENTILATION AIR BY ONE OF THE METHODS DESCRIBED IN THE NATIONAL FUEL GAS CODE ANSI Z223.1/ NFPA 54 , AIR FOR COMBUSTION AND VENTILATION, OR THE APPLICABLE LOCAL CODE.

IF THE AREA IN WHICH THE APPLIANCE MAY BE OPERATED DOES NOT MEET THE REQUIRED VOLUME FOR INDOOR COMBUSTION AIR, COMBUSTION AND VENTILATION AIR SHALL BE PROVIDED BY ONE OF THE METHODS DESCRIBED IN THE ANSI Z223.1 / NFPA 54, THE INTERNATIONAL FUEL GAS CODE, OR APPLICABLE LOCAL CODES.

Unusually tight construction is defined as construction where:

- A) Walls and ceilings exposed to the outside atmosphere have a continuous water vapour retarder with a rating of 1 perm (6 x 10⁻¹¹ kg per pa-sec-m²) or less with openings gasketed or sealed, and
- B) Weather stripping has been added on openable windows and doors, and
- C) Caulking or sealants are applied to areas such as joints around window and door frames, between sole plates and floors, between wall-ceiling joints, between wall panels, at penetrations for plumbing, electrical, and gas lines, and at other openings.

An unvented room appliance is recommended for use as a secondary heat source rather than as a primary source. Gas combustion produces water vapour which could occur at the rate of approximately one ounce of water for every 1,000 BTU/hr of gas input. During the cold weather season, indoor humidity levels tend to be low. Consequently, this water vapour can enhance the living space. However if a problem should occur:

- A) Ensure sufficient combustion and circulation air
- B) Use a dehumidifier
- C) Do not use the unvented room appliance as a primary heat source

Without sufficient fresh air for proper operation, poor fuel combustion can result. Carbon Monoxide is a result of poor combustion.

If additional fresh air is required, use one of the methods described in the National Fuel Gas Code, ANSI Z223.1 / NFPA54 or the applicable local code.

Room Volume = Length x Width x Height
 Max BTU/hr = Room Volume x 1000 / 50

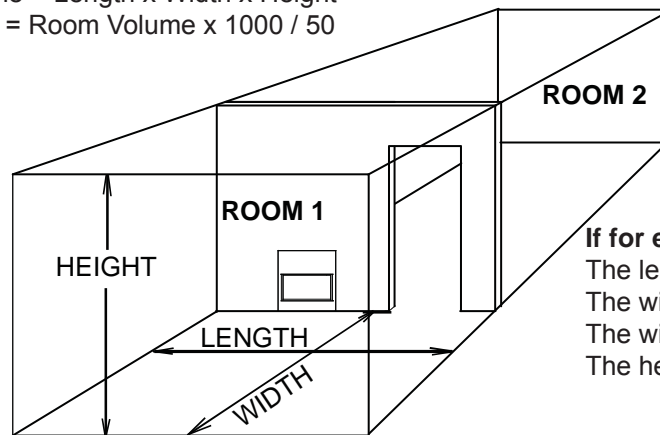

If for example:

The length of the rooms is 10 feet,
 The width of Room 1 is 10 feet,
 The width of Room 2 is 15 feet,
 The height of the rooms is 8 feet.

The volume of Room 1: 10x10x8 = 800 cubic feet
 The volume of Room 2: 10x15x8 = 1200 cubic feet

19.1B

EXAMPLE 1:

In this example, because there is no door to the adjoining room, the volume of the adjoining room may be added to the volume of the room with the heater to get a total unconfined space.

The total unconfined space: 800 + 1200 = 2000 cubic feet.

Maximum BTU/h: $\frac{2000 \times 1000}{50} = 40,000$ BTU/h

19.2

If there are no more fuel burning appliances within this space then the 6,000 BTU/h input of the appliance is suitable to be installed. This also assumes that the construction of this space is not unusually tight.

EXAMPLE 2:

If in this example a solid door separates Room 1 from Room 2, the volume of Room 2 could not be used. In this case the maximum BTU/h would be:

Maximum BTU/h: $\frac{800 \times 1000}{50} = 16,000$ BTU/h

19.3

If there are no more fuel burning appliances within this space then the 6,000 BTU/h input of the appliance is suitable to be installed. This also assumes that the construction of this space is not unusually tight.

3.3 GAS INSTALLATION

! WARNING
RISK OF FIRE, EXPLOSION OR ASPHYXIATION. ENSURE THERE ARE NO IGNITION SOURCES SUCH AS SPARKS OR OPEN FLAMES.
SUPPORT GAS CONTROL WHEN ATTACHING GAS SUPPLY PIPE TO PREVENT DAMAGING GAS LINE.
ALWAYS LIGHT THE PILOT WHETHER FOR THE FIRST TIME OR IF THE GAS SUPPLY HAS RUN OUT WITH THE GLASS DOOR OPENED OR REMOVED. PURGING OF THE GAS SUPPLY LINE SHOULD BE PERFORMED BY A QUALIFIED SERVICE TECHNICIAN. ASSURE THAT A CONTINUOUS GAS FLOW IS AT THE BURNER BEFORE CLOSING THE DOOR. ENSURE ADEQUATE VENTILATION. FOR GAS AND ELECTRICAL LOCATIONS, SEE "DIMENSION" SECTION.
ALL GAS CONNECTIONS MUST BE CONTAINED WITHIN THE APPLIANCE WHEN COMPLETE.
HIGH PRESSURE WILL DAMAGE VALVE. DISCONNECT GAS SUPPLY PIPING BEFORE TESTING GAS LINE AT TEST PRESSURES ABOVE 1/2 PSIG.
VALVE SETTINGS HAVE BEEN FACTORY SET, DO NOT CHANGE.

Installation and servicing to be done by a qualified installer.

- A. Move the appliance into position and secure.
- B. If equipped with a flex connector the appliance is designed to accept a 1/2" gas supply. Without the connector it is designed to accept a 3/8" gas supply. The appliance is equipped with a manual shut off valve to turn off the gas supply to the appliance.
- C. Connect the gas supply in accordance to local codes. In the absence of local codes, install to the current CAN/CSA-B149.1 Installation Code in Canada or to the current National Fuel Gas Code, ANSI Z223.1 / NFPA 54 in the United States.
- D. When flexing any gas line, support the gas valve so that the lines are not bent or kinked.
- E. The gas line flex-connector should be installed to provide sufficient movement for shifting the burner assembly on it's side to aid with servicing components.
- F. Check for gas leaks by brushing on a soap and water solution. **Do not use open flame.**

30.1A

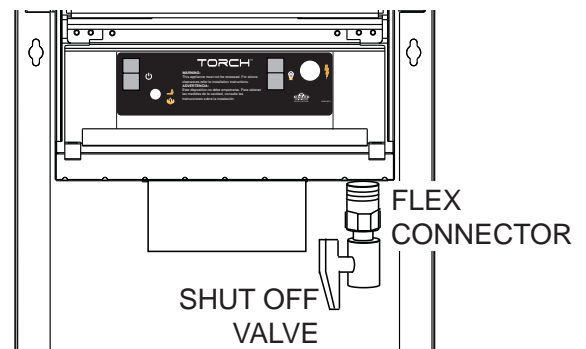

3.4 GAS PRESSURE

Outlet pressure can be checked to ensure it is measuring 3.5" W.C. (NG) or 10.0" W.C. (LP).

- A. Outlet pressure can be checked by removing cap (A) using a 3/16 Allen key and replacing it with a 1/8 NPT barb fitting.
- B. Place pressure gauge tube over the fitting.
- C. Once completed, be sure to replace the cap (A).

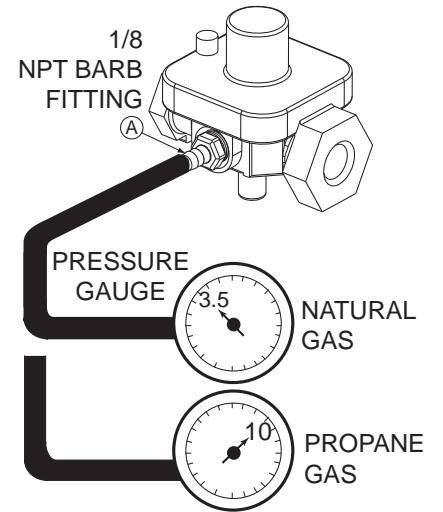

4.0 FRAMING

4.1 CLEARANCE TO COMBUSTIBLES

! WARNING

THIS APPLIANCE MUST BE INSTALLED IN THE CABINET PROVIDED. THE CABINET IS DESIGNED TO BE INSTALLED ON FINISHED SURFACES.

THIS APPLIANCE CAN BE RECESSED INTO AN ALCOVE A MAXIMUM OF 12" PROVIDED THAT ALL CLEARANCES ARE MAINTAINED.

THE CABINET MAY BE INSTALLED DIRECTLY ONTO A COMBUSTIBLE SURFACE.

MINIMUM CLEARANCES TO COMBUSTIBLES:

- 18" to top
- 1" to sides
- 8" to bottom
- 0" to rear (cabinet)
- 1/2" to rear (appliance)

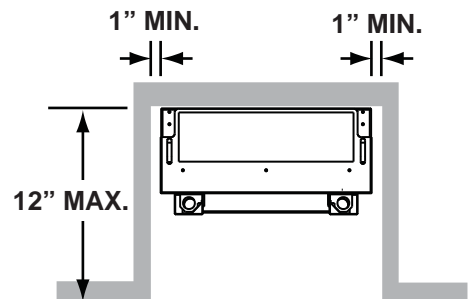
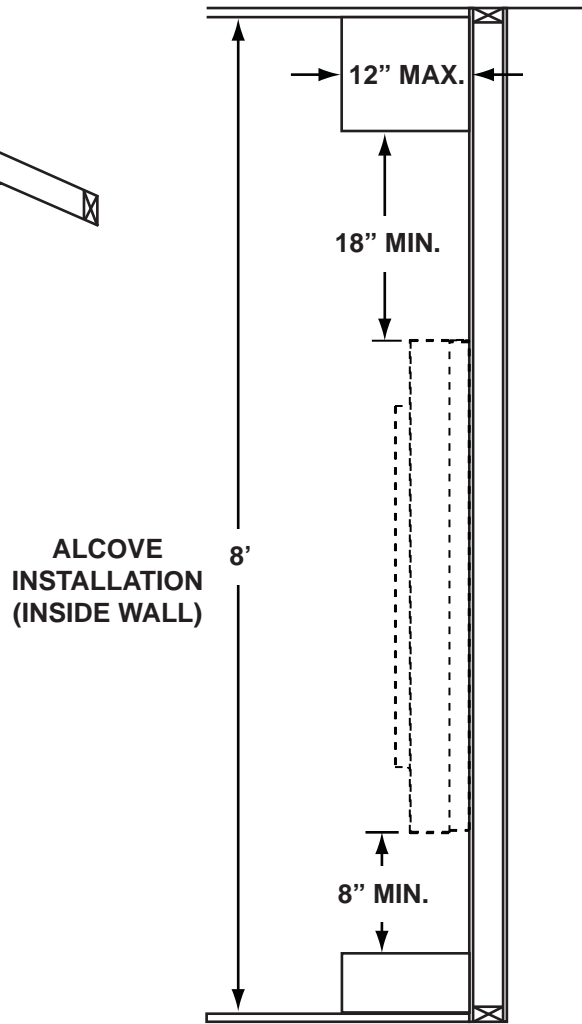
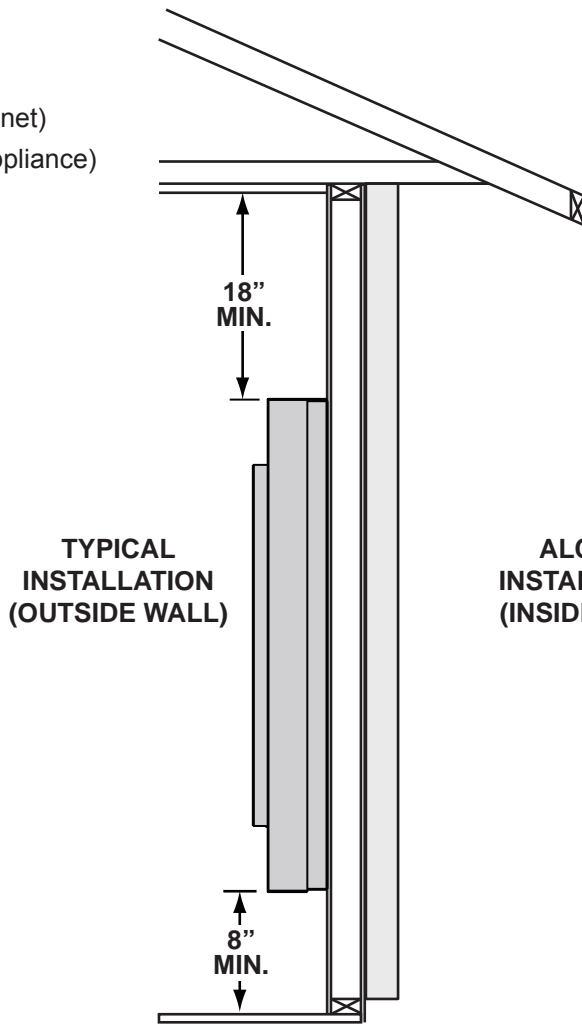

5.0 FINISHING

5.1 MOUNTING CABINET INSTALLATION

! WARNING

DEFLECTOR MUST BE INSTALLED.

- A. Using the installation template (W122-0401) supplied, determine the best mounting location for your new Torch, see “DIMENSIONS” or “MINIMUM CLEARANCE TO COMBUSTIBLES” section. Mark all 14 hole centres on the wall (surface) using the template.
- B. Align the holes on the deflector with the holes on the back of the torch as illustrated. Secure with the appropriate fasteners.
- C. Remove the template. Depending on the surface and fasteners, drill the appropriate holes. Hold the Torch up, aligning the mounting brackets to the mounting holes. Secure the Torch to the wall using the appropriate fasteners.

NOTE: The Torch has been designed to have a 1/2” clearance between the rear outer panel and the mounting surface.

- D. Start the fasteners into each of the six remaining mounting holes. Align the keyholes of the frame to the heads of the fasteners and slide the frame down onto the fasteners. Ensure the frame is plumb and level before tightening the fasteners.

NOTE: It is recommended that the gas and electrical be connected to the appliance at this stage. Both must enter the appliance at the opening created between the bottom of the Torch and the bottom of the mounting frame.

- E. Slide the front of the cabinet over the mounting frame, ensuring the “mesh” is to the top. Start each of the four screws (supplied) through the slots. Once the cabinet has been adjusted for depth the four screws can be tightened.

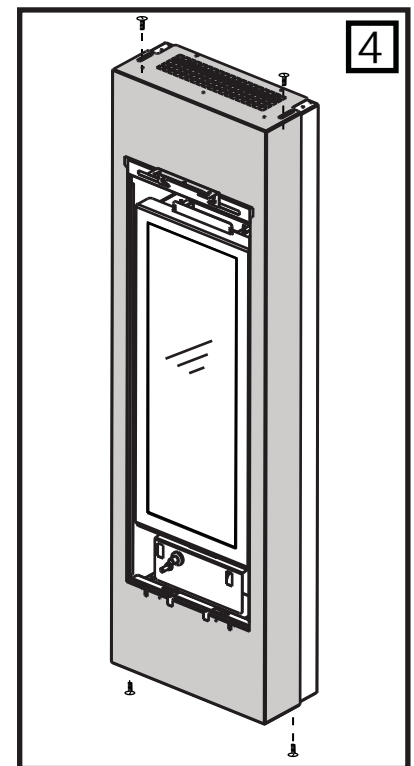
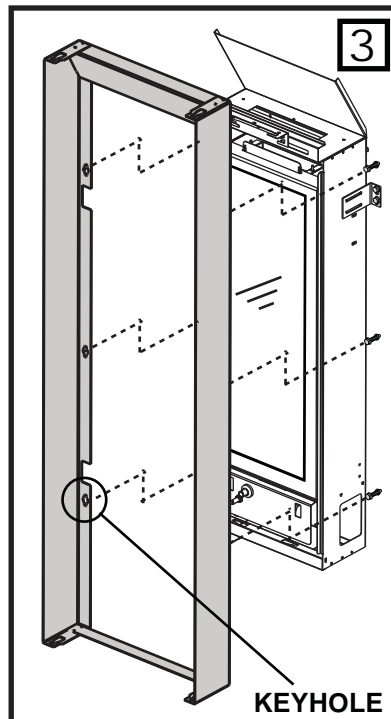
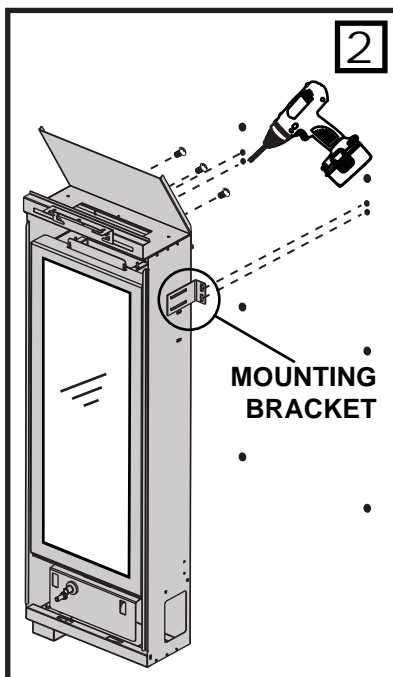
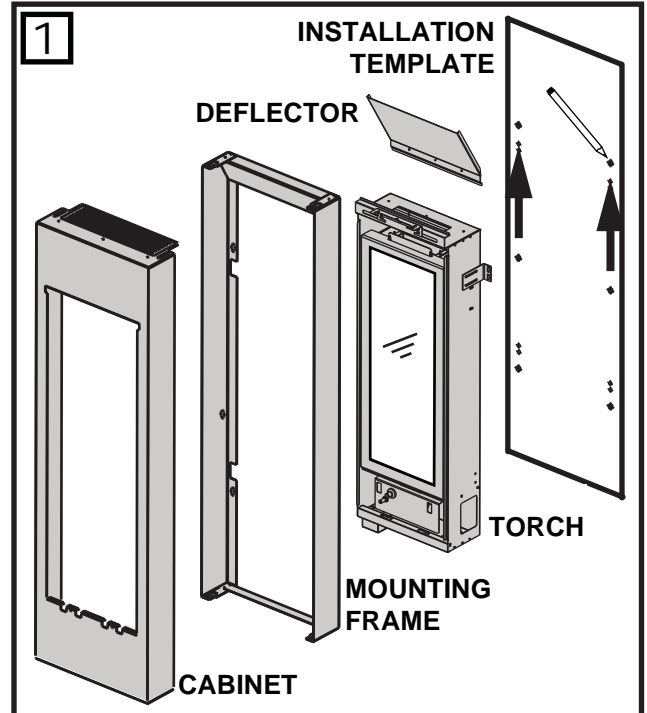

! WARNING

GLASS MAY BE HOT, DO NOT TOUCH GLASS UNTIL COOLED.

THE DOOR LATCHES ARE PART OF A SAFETY SYSTEM AND MUST BE PROPERLY ENGAGED. DO NOT OPERATE THE APPLIANCE WITH LATCHES DISENGAGED.

FACING AND/OR FINISHING MATERIALS MUST NOT INTERFERE WITH AIR FLOW THROUGH AIR OPENINGS, LOUVRES OPENINGS, OPERATION OF LOUVRES OR DOORS OR ACCESS FOR SERVICE. OBSERVE ALL CLEARANCES WHEN APPLYING COMBUSTIBLE MATERIALS.

BEFORE DOOR IS REMOVED TURN THE APPLIANCE OFF AND WAIT UNTIL APPLIANCE IS COOL TO THE TOUCH. DOORS ARE HEAVY AND FRAGILE SO HANDLE WITH CARE.

75.1

The door is held in place at the bottom by a retainer tab that inserts into a slot in the bottom edge of the door, and at the top with a tab that secures in the same fashion. The door is removed by lifting it off the tabs. When replacing, guide the door over the upper tab first, then over the lower tab.

SECURING THE DOOR IN PLACE

When shipped, the door is secured with two hitch pins along the top edge, replacing them is optional. To secure the door in place use the supplied hitch pins as illustrated.

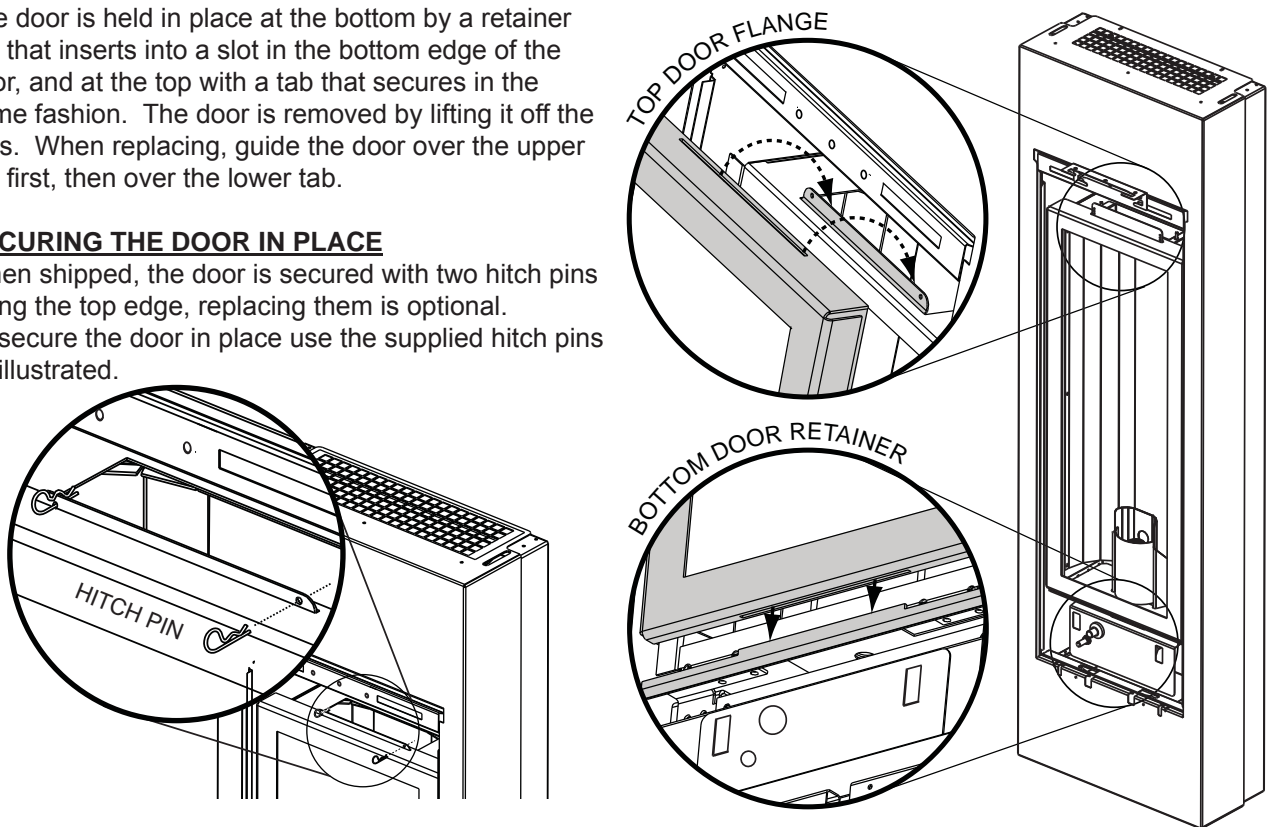

5.3 FRAME INSTALLATION

- A.** Align the two holes in the upper portion of the hinge on the control door to those in the bottom trim bracket, secure using two of the #8 x 1/2" hex head screws supplied.
- B.** Install the top trim bracket to the firebox using the three #9 - 14 x 1/2" hex head screws supplied in the TORCH[®] manual baggie.
- C.** Rest the top lip of the TORCH[®] frame on the top trim bracket, and the securing tabs at the bottom of the TORCH[®] frame on the bottom trim bracket.
- D.** Align the two slots in the top of the TORCH[®] frame with the two holes in the top trim bracket and secure using the two #10 pan head screws supplied however do not fully tighten to leave room for adjustment.
- E.** Align the holes in the securing tabs at the bottom of the TORCH[®] frame with the holes in the bottom trim bracket and secure using the two remaining #8 x 1/2" hex head screws, however do not fully tighten to leave room for adjustment.
- F.** If required, the bottom trim bracket can be adjusted by loosening it's securing screws.
- G.** Once the TORCH[®] frame is perfectly square and the control door will close without rubbing against the sides of the TORCH[®] frame, tighten all screws.
- H.** Open the control door.
- I.** Insert the door stop chain into the receiving slot in the control door.
- J.** Insert the door stop chain into the receiving slot in the TORCH[®] frame so that when fully open the control door has a clearance of 1/8" to the finished wall. **NOTE: In most cases, a count of 9 balls between receiving slots will give the desired clearance.**
- K.** Close the control door.

The TORCH[®] frame has been designed to accommodate finished material thicknesses of .500" - .750". If it is necessary to pull the TORCH[®] frame out to the max. .750" the magnetic catch will need to be adjusted. Minor adjustment can be made by removing shims from behind the magnet. Major adjustments can be made by moving the magnet to the outside of the panel.

Adjustment may be required to accommodate the door stop chain slack when the control door is closed. The control door securing screws can be loosened to allow adjustment. Before re-tightening the screws ensure the control door is still recessed into the TORCH[®] frame at a similar offset to the top trim piece.

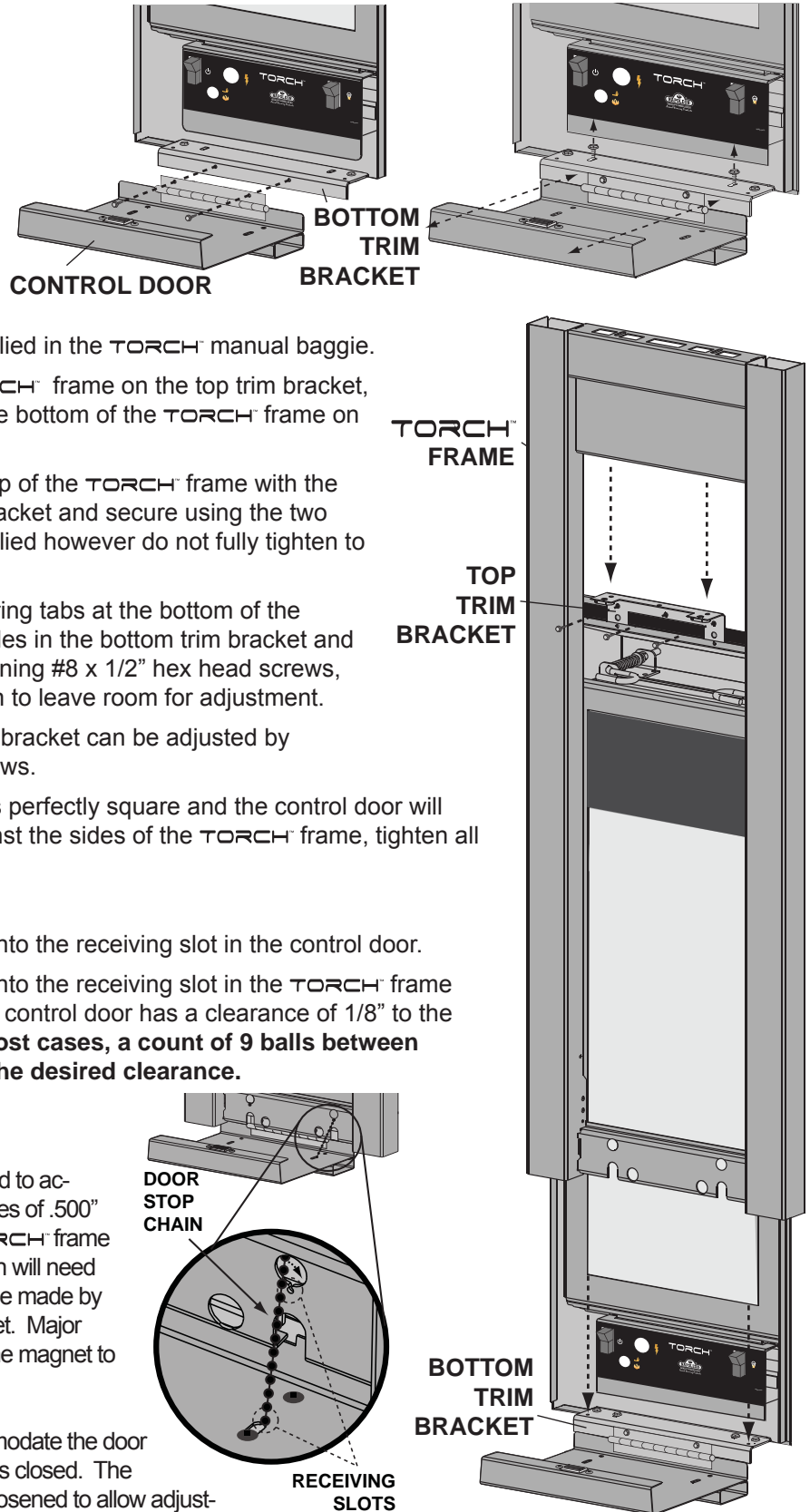

5.4 LOGO PLACEMENT

With the control door closed, affix the logo to the front face of the control door at the bottom left corner.

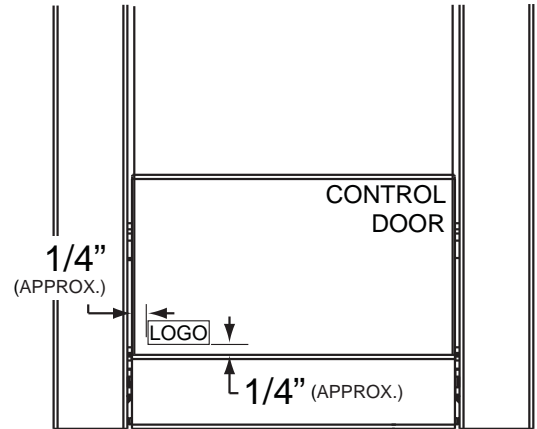

5.5 GLASS MEDIA INSTALLATION

! WARNING

CLEAN THE GLASS MEDIA PRIOR TO INSTALLATION. BEFORE APPLYING THE CLEANED GLASS, ENSURE THAT IT IS DRY.

DO NOT CHANGE OR SUBSTITUTE THE GLASS MEDIA MATERIAL PROVIDED WITH THIS APPLIANCE. IF REPLACING, USE ONLY THE REPLACEMENT GLASS MEDIA AVAILABLE FROM YOUR AUTHORIZED DEALER / DISTRIBUTOR.

Evenly spread the glass media onto the media tray, ensuring no glass media falls into the pilot opening. If this happens, insert a clean bag into your vacuum cleaner and vacuum out the glass media. Replacement glass can be purchased from your local authorized dealer / distributor.

CLEANING GLASS MEDIA

Glass media may have a fine oil residue that needs to be cleaned prior to installation. Clean the glass with mild dish soap, drain, rinse thoroughly and dry before placing around the burner.

74.2A

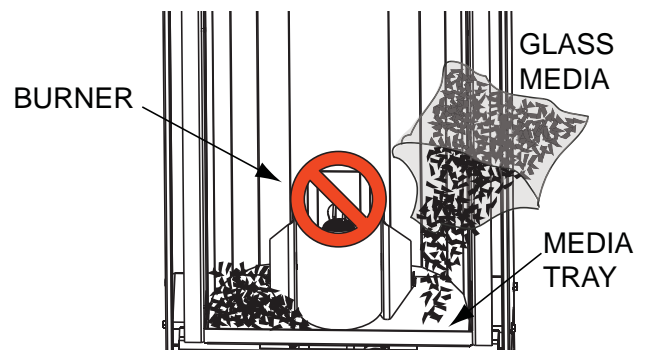

5.6 LK8 LIGHT INSTALLATION (OPTIONAL)

- A. Turn off the electrical and gas supply to the appliance.
- B. Remove the frame from the appliance by removing the 2 stainless steel hex head securing screws from the bottom and lifting the frame off of the top trim bracket.
- C. Lay the frame down on its front, being careful not to scratch the finish.
- D. Starting at the top of the frame, take one light assembly and carefully snap it into place in the hole provided. Repeat for each of the light assemblies. The wires on the top 2 light assemblies will need to be fed in behind the heat shields.

NOTE: When installing the light kit be careful not to scratch your fingers on any of the exposed screws in the frame.

- E. Connect the light assemblies to the appropriate flags on the wire harness. The wire harness is labeled (TR) top right, (BR) bottom right (TL) Top left and (BL) bottom left.
- F. Secure the wires into the clips at both sides and the bottom of the frame. Use the extra clips provided to retain any loose wires.
- G. Re-attach frame onto appliance.
- H. Open the control panel door, leave the wires connected to the ON/OFF switch and place the transformer into the bottom of the appliance. Plug the transformer into the receptacle.
- I. Attach one of the wire leads from the transformer to the lead on the wire harness labeled "TRANS", and the other to the ON/OFF switch. Attach the last lead on the wire harness labeled "SWI" to the ON/OFF switch.
- J. Close the control panel door.
- K. Turn on the gas supply and electrical power.

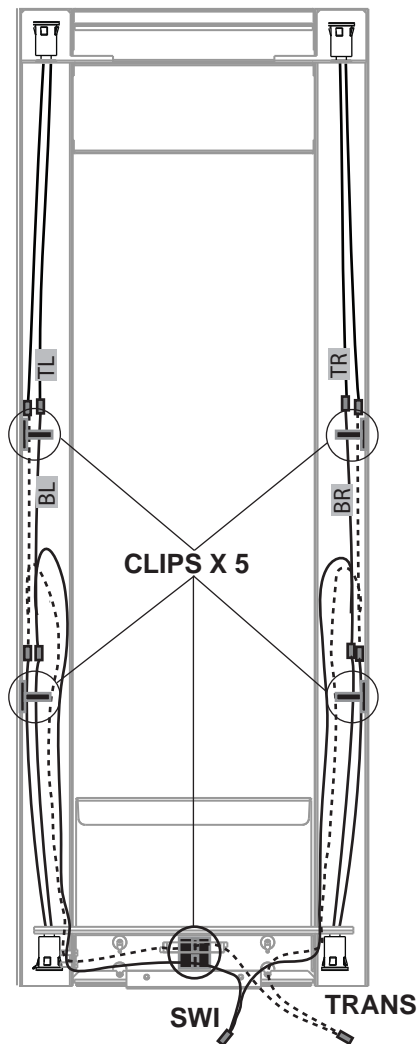

6.0 ELECTRICAL INFORMATION

! WARNING

DO NOT USE THIS APPLIANCE IF ANY PART HAS BEEN UNDER WATER. CALL A QUALIFIED SERVICE TECHNICIAN IMMEDIATELY TO HAVE THE APPLIANCE INSPECTED FOR DAMAGE TO THE ELECTRICAL CIRCUIT.

RISK OF ELECTRICAL SHOCK OR EXPLOSION. DO NOT WIRE 110V TO THE VALVE OR TO THE APPLIANCE WALL SWITCH. INCORRECT WIRING WILL DAMAGE CONTROLS.

ALL WIRING SHOULD BE DONE BY A QUALIFIED ELECTRICIAN AND SHALL BE IN COMPLIANCE WITH LOCAL CODES. IN THE ABSENCE OF LOCAL CODES, USE THE CURRENT CSA C22.1 CANADIAN ELECTRIC CODE IN CANADA OR THE CURRENT NATIONAL ELECTRIC CODE ANSI/NFPA NO. 70 IN THE UNITED STATES.

It is not necessary to hard wire this appliance, however if accessories that do require power are being considered it is recommended to make your electrical connection during initial installation.

As illustrated, route a grounded 2-wire, 60HZ power cable to the junction box. At this point it must be strain relieved and insulated.

10.1

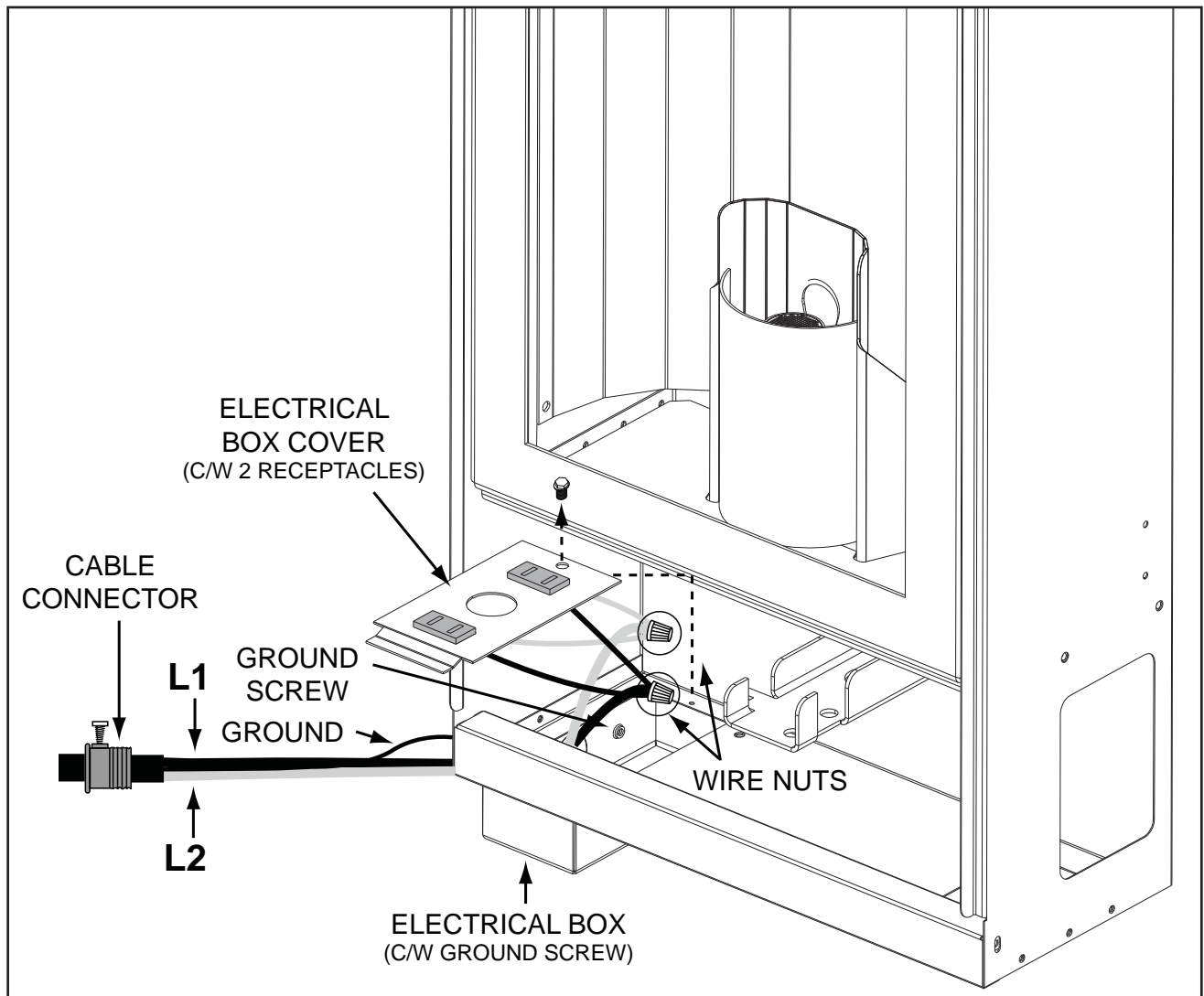

7.0 OPERATION

! WARNING

IF YOU DO NOT FOLLOW THESE INSTRUCTIONS EXACTLY, A FIRE OR EXPLOSION MAY RESULT CAUSING PROPERTY DAMAGE, PERSONAL INJURY OR LOSS OF LIFE.

ALWAYS LIGHT THE PILOT WHETHER FOR THE FIRST TIME OR IF THE GAS SUPPLY HAS RUN OUT WITH THE GLASS DOOR OPENED OR REMOVED.

If appliance shuts off, do not relight until you provide fresh air. If appliance keeps shutting off, have it serviced. Keep burner and control compartment clean.

When lit for the first time, the appliance will emit a slight odour for a few hours. This is a normal temporary condition caused by the “burn-in” of internal paints and lubricants used in the manufacturing process and will not occur again. After extended periods of non-operation such as following a vacation or a warm weather season, the appliance may emit a slight odour for a few hours. This is caused by dust particles burning off. In both cases, open a window to sufficiently ventilate the room.

FOR YOUR SAFETY READ BEFORE LIGHTING:

- A.** This appliance is equipped with a pilot which must be lit by hand while following these instructions exactly.
- B.** Before operating smell all around the appliance area for gas and next to the floor because some gas is heavier than air and will settle on the floor.
- C.** Use only your finger to push in the gas control. Never use tools. If the control will not push in, do not try to repair it. Call a qualified service technician. Force or attempted repair may result in a fire or explosion.
- D.** Do not use this appliance if any part has been under water. Immediately call a qualified service technician to inspect the appliance and replace any part of the control system and any gas control which has been under water.

WHAT TO DO IF YOU SMELL GAS:

- Do not try to light any appliance.
- Do not touch any electric switch; do not use any phone in your building.
- Immediately call your gas supplier from a neighbour’s phone. Follow the gas supplier’s instructions.
- If you cannot reach your gas supplier, call the fire department.

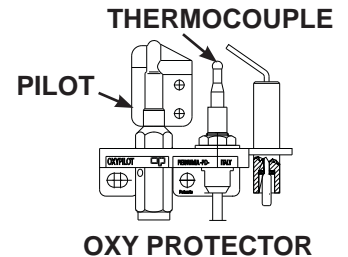

LIGHTING INSTRUCTIONS:

- 1. STOP!** Read the safety information located above.
- 2.** Turn off all electric power to the fireplace.
- 3.** Open the control door.
- 4.** Wait five (5) minutes to clear out any gas. If you smell gas including near the floor, STOP! Follow “B” in the above safety information on this label. If you don’t smell gas go to the next step.
- 5.** Find pilot located behind the burner.
- 6.** Ensure the on/off switch is in the on position.
- 7.** Depress and hold gas control while lighting the pilot with the push button ignitor. Keep control fully depressed for one minute, then release. If pilot does not continue to burn repeat steps 3 through 7.
- 8.** Releasing the gas control will also ignite the main burner.
- 9.** Turn on all electric power to the appliance if service is to be performed.

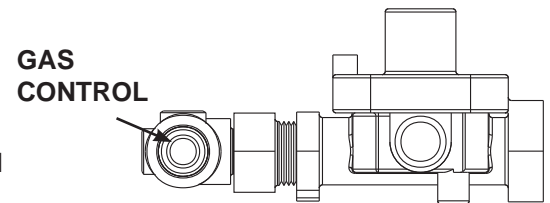

TO TURN OFF GAS:

- 1.** Turn off all electrical power to the appliance if service is to be performed.
- 2.** Push the on/off switch to the off position.

47.15

8.0 ADJUSTMENTS

8.1 VENTURI ADJUSTMENT

This model has an air shutter that has been factory set open according to the chart below:

Closing the air shutter will cause a more yellow flame, but can lead to carboning. Opening the air shutter will cause a more blue flame, but can cause flame lifting from the burner ports. The flame may not appear yellow immediately; allow 15 to 30 minutes for the final flame color to be established.

AIR SHUTTER ADJUSTMENT MUST ONLY BE DONE BY A QUALIFIED INSTALLER!

NOTE: It is important that the venturi sits down tight on the orifice.

AIR SHUTTER OPENINGS	
LP	3/16" DIA
NG	1/16" DIA

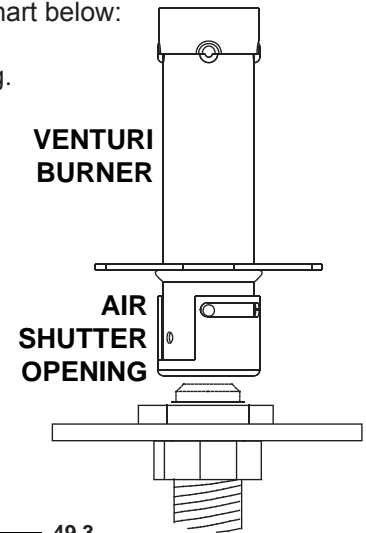

8.2 FLAME CHARACTERISTICS

It is important to periodically perform a visual check of the burner flame. Compare them to the illustration provided.

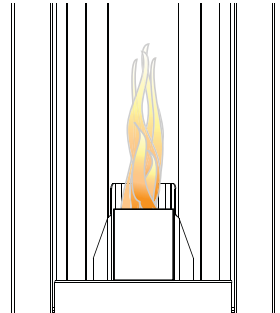

9.0 MAINTENANCE

TURN OFF THE GAS AND ELECTRICAL POWER BEFORE SERVICING THE APPLIANCE.

CAUTION: Label all wires prior to disconnection when servicing controls. Wiring errors can cause improper and dangerous operation. Verify proper operation after servicing. This appliance should be inspected before use and at least annually by a qualified service person. The appliance area must be kept clear and free of combustible materials, gasoline or other flammable vapours and liquids. The flow of combustion and ventilation air must not be obstructed.

- A. Keep the control compartment, burner, and air shutter opening clean by vacuuming or brushing, at least once a year.
- B. Check to see that the main burner ignites when the switch for the burner is turned on. A 5 second light-up period is satisfactory. If ignition takes longer, consult your authorized dealer.
- C. Check that the gasketing on the sides and top of the door are not broken or missing. Replace if necessary.

9.1 CLEANING

- Visually inspect the appliance for carbon buildup.
- Using a small whisk or brush, brush off the excess carbon and vacuum up or sweep into the garbage.
- Check the appliance for corrosion of the main burner base.

This procedure must be performed by a qualified service person!
Inspect the pilot for any visible contamination or debris (usually lint, pet hair, spider webs, carpet fibre, etc.) and remove.

Disconnect the pilot from the pilot tubing line, using a 1/2" wrench. Blow out the housing in the same direction as the gas flow. Re-install the pilot tube, turn on the gas and check for leaks.

If this does not improve the performance, replace the Oxy Protector with an exact replacement. The device is tamper resistant with no field serviceable parts.

CORRECT PILOT FLAME
(Clean, stable, pronounced blue flame).

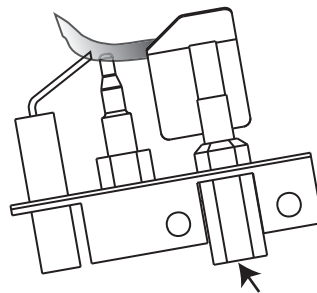

HOUSING

INCORRECT PILOT FLAME
(Flame lifts upwards, becomes unstable with more of an orange tip).

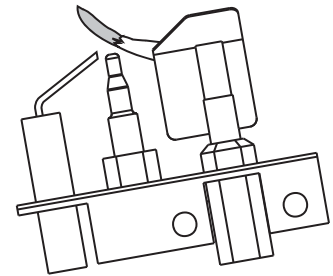

46.2

9.2 CARE OF GLASS

DO NOT CLEAN GLASS WHEN HOT! DO NOT USE ABRASIVE CLEANERS TO CLEAN GLASS.

Buff lightly with a clean dry soft cloth. Clean both sides of the glass after the first 10 hours of operation with a recommended fireplace glass cleaner. Thereafter clean as required. If the glass is not kept clean permanent discoloration and / or blemishes may result.



5.1

9.3 DOOR GLASS REPLACEMENT

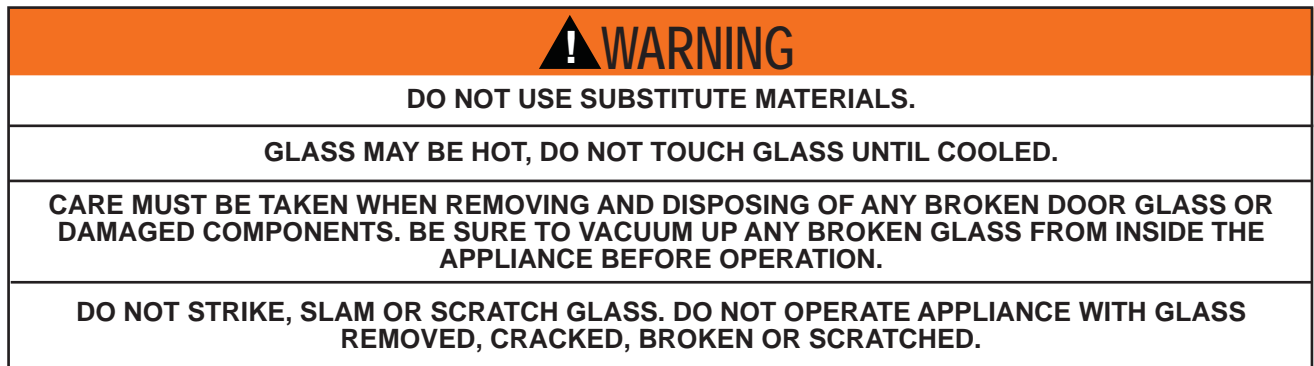

56.2

Having removed the door, lay on a smooth flat surface, face down. There are 4 glass retainers that need to be bent away from the glass to release it from the frame. Do not pry on the glass.

When replacing **DO NOT SUBSTITUTE MATERIAL**, replace the gasket (W562-0008) and the glass (W300-0110). Set new glass into the frame and gently bend tabs into the gasket to secure.

* Ensure that the gasketed end of the glass is placed into the top of the door frame.

NOTE: Care must be taken when removing and disposing of any broken glass or damaged components. Be sure to vacuum up any broken glass from inside the appliance before operation.

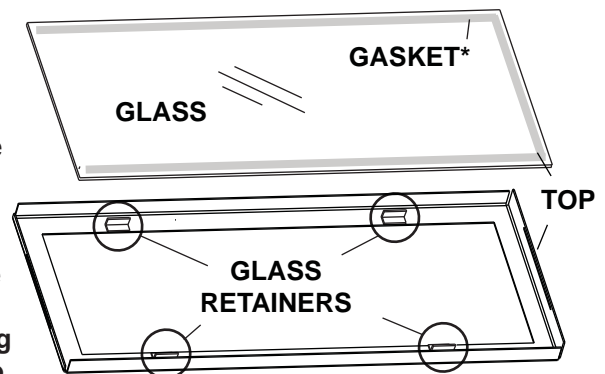

10.0 REPLACEMENTS

Contact your dealer or the factory for questions concerning prices and policies on replacement parts. Normally all parts can be ordered through your Authorized dealer / distributor.

FOR WARRANTY REPLACEMENT PARTS, A PHOTOCOPY OF THE ORIGINAL INVOICE WILL BE REQUIRED TO HONOUR THE CLAIM.

When ordering replacement parts always give the following information:

- Model & Serial Number of appliance
- Installation date of appliance
- Part number
- Description of part
- Finish

*** IDENTIFIES ITEMS WHICH ARE NOT ILLUSTRATED. FOR FURTHER INFORMATION, CONTACT YOUR AUTHORIZED DEALER.**

! WARNING

FAILURE TO POSITION THE PARTS IN ACCORDANCE WITH THIS MANUAL OR FAILURE TO USE ONLY PARTS SPECIFICALLY APPROVED WITH THIS APPLIANCE MAY RESULT IN PROPERTY DAMAGE OR PERSONAL INJURY.

41.1

COMPONENTS		
REF	PART NO.	DESCRIPTION
1	W225-0251	DOOR FRAME
2	W562-0008	DOOR GASKET
3	W010-1959	GLASS C/W GASKET
4 *	W300-0132	GLASS
5	W100-0104	BURNER
6	W200-0263	IGNITOR COVER
7	W200-0262	BURNER COVER
8*	W725-0060	NATURAL GAS VALVE - 3.5" W.C.
9	W137-0001	CERAMIC CATALYST
10	W662-0006	OXY PROTECTOR - NG
10	W662-0007	OXY PROTECTOR - LP
11	W530-0028	REGULATOR - NG
11	W530-0029	REGULATOR - LP
12*	W455-0085	#56 NATURAL GAS ORIFICE
12*	W455-0086	#69 PROPANE GAS ORIFICE
13	W475-0590	BACK PANEL
14*	W300-0108	ACCESS GLASS (BLACK)
15*	W385-0334	NAPOLEON LOGO
16*	W562-0046	ROPE GASKET, BACK PANEL
17*	W385-0479	CONTROL PANEL LABEL
18	W200-0300	CONTROL PANEL
19	W660-0088	ROCKER SWITCH - ON/OFF
20	W660-0082	ROCKER SWITCH - LIGHTS

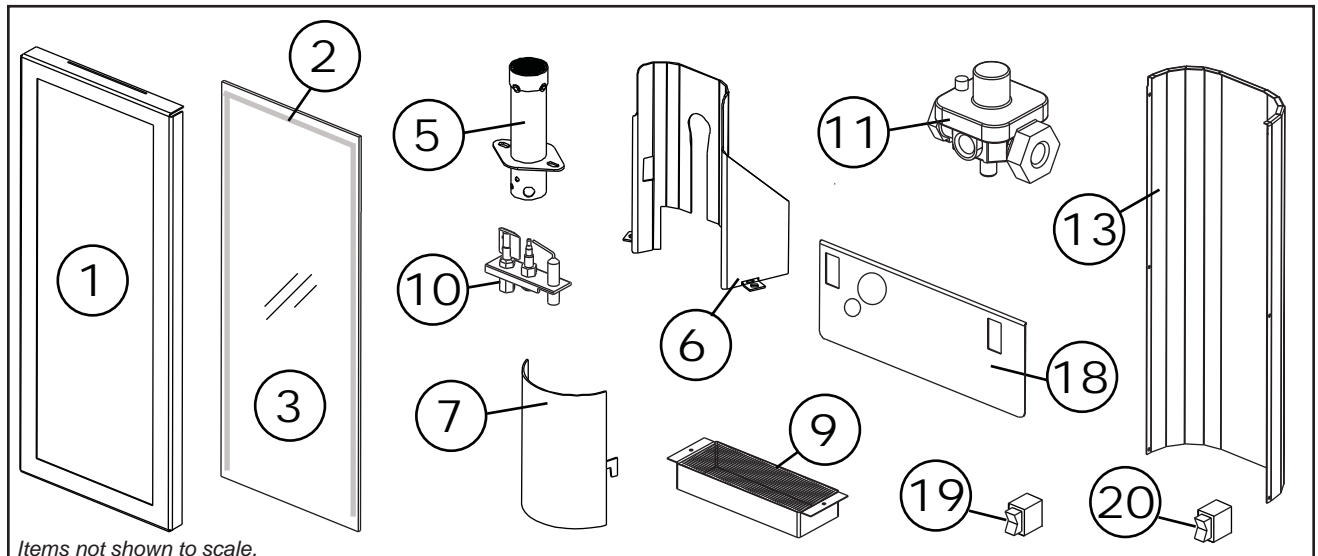

ACCESSORIES		
REF	PART NO.	DESCRIPTION
21	TMCSS	MOUNTING CABINET
22	TFSSO	FRAME KIT
23*	LK8	LIGHT KIT

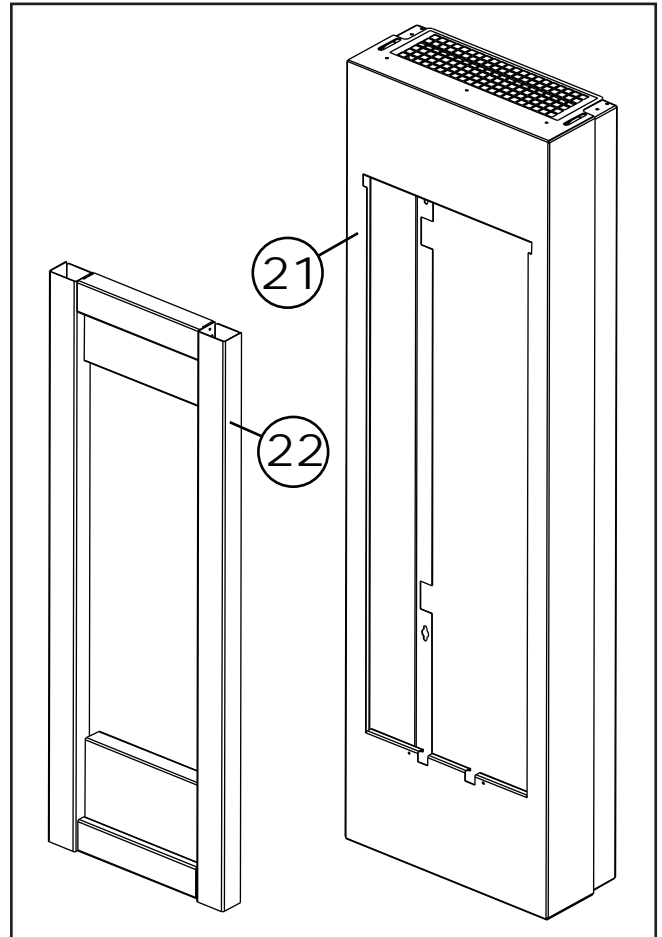

11.0 TROUBLESHOOTING

 WARNING
ALWAYS LIGHT THE PILOT WHETHER FOR THE FIRST TIME OR IF THE GAS SUPPLY HAS RAN OUT, WITH THE GLASS DOOR OPEN OR REMOVED.
TURN OFF THE GAS AND ELECTRICAL POWER BEFORE SERVICING THE APPLIANCE.
APPLIANCE MAY BE HOT, DO NOT SERVICE UNTIL APPLIANCE HAS COOLED.
DO NOT USE ABRASIVE CLEANERS.

SYMPTOM	PROBLEM	TEST SOLUTION
Flame length consistently too large or too small. Carboning occurs.	Unit is over-fired or under-fired.	<ul style="list-style-type: none"> - Check pressure readings. - Outlet pressure can be checked by removing cap (A) and replacing it with a 1/8" NPT barb fitting. Next, place pressure gauge tubing over the fitting. Gauge should read 3.5" W.C. for natural gas or 10.0" W.C. for propane. AFTER TAKING PRESSURE READINGS, BE SURE TO REPLACE CAP TO RESEAL. DO NOT OVER-TORQUE. - Leak test with a soap and water solution.
Carbon is being deposited on glass, and combustion chamber surfaces.	Air shutter has become blocked.	<ul style="list-style-type: none"> - Ensure air shutter opening is free of lint or other obstructions.
	Flame is impinging on the combustion chamber.	<ul style="list-style-type: none"> - Open air shutter to increase the primary air. - Check the input rate: check the manifold pressure and orifice size as specified by the rating plate values.
White / grey film forms.	Sulphur from fuel is being deposited on glass, logs, rocks, media or combustion chamber surfaces.	<ul style="list-style-type: none"> - Clean the glass with a gas appliance glass cleaner. DO NOT CLEAN GLASS WHEN HOT. If deposits are not cleaned off regularly, the glass may become permanently marked.
No gas to the main burner; switch is on.	Switch is defective.	<ul style="list-style-type: none"> - Connect a jumper wire across the wall switch terminals; if main burner lights, replace switch.
	Burner orifice is blocked.	<ul style="list-style-type: none"> - Remove stoppage in orifice.
	Control valve faulty.	<ul style="list-style-type: none"> - Replace.
	Faulty valve.	<ul style="list-style-type: none"> - Replace.
Burner will not light, ignitor sparks.	No gas at the burner.	<ul style="list-style-type: none"> - Check that the manual valve is turned on. - Replace the valve.
	Out of propane gas.	<ul style="list-style-type: none"> - Fill the tank.

42.11

12.0 WARRANTY

NAPOLEON® products are manufactured under the strict Standard of the world recognized ISO 9001 : 2008 Quality Assurance Certificate.

NAPOLEON® products are designed with superior components and materials assembled by trained craftsmen who take great pride in their work. The burner and valve assembly are leak and test-fired at a quality test station. The complete appliance is again thoroughly inspected by a qualified technician before packaging to ensure that you, the customer, receives the quality product that you expect from NAPOLEON®.

NAPOLEON® GAS APPLIANCE PRESIDENT'S LIFETIME LIMITED WARRANTY

The following materials and workmanship in your new NAPOLEON® gas appliance are warranted against defects for as long as you own the appliance. This covers: combustion chamber, heat exchanger, stainless steel burner, phazer™ logs and embers, rocks, ceramic glass (thermal breakage only), gold plated parts against tarnishing, porcelainized enameled components and aluminum extrusion trims.*

Electrical (110V and millivolt) components and wearable parts such as blowers, gas valves, thermal switch, switches, wiring, remote controls, ignitor, gasketing, and pilot assembly are covered and NAPOLEON® will provide replacement parts free of charge during the first year of the limited warranty.*

Labour related to warranty repair is covered free of charge during the first year. Repair work, however, requires the prior approval of an authorized company official. Labour costs to the account of NAPOLEON® are based on a predetermined rate schedule and any repair work must be done through an authorized NAPOLEON® dealer.

* Construction of models vary. Warranty applies only to components included with your specific appliance.

CONDITIONS AND LIMITATIONS

NAPOLEON® warrants its products against manufacturing defects to the original purchaser only. Registering your warranty is not necessary. Simply provide your proof of purchase along with the model and serial number to make a warranty claim. NAPOLEON® reserves the right to have its representative inspect any product or part thereof prior to honouring any warranty claim. Provided that the purchase was made through an authorized NAPOLEON® dealer your appliance is subject to the following conditions and limitations:

Warranty coverage begins on the date of original installation.

This factory warranty is non-transferable and may not be extended whatsoever by any of our representatives.

The gas appliance must be installed by a licensed, authorized service technician or contractor. Installation must be done in accordance with the installation instructions included with the product and all local and national building and fire codes.

This limited warranty does not cover damages caused by misuse, lack of maintenance, accident, alterations, abuse or neglect and parts installed from other manufacturers will nullify this warranty.

This limited warranty further does not cover any scratches, dents, corrosion or discoloring caused by excessive heat, abrasive and chemical cleaners nor chipping on porcelain enamel parts, mechanical breakage of PHAZER™ logs and embers.

This warranty extends to the repair or replacement of warranted parts which are defective in material or workmanship provided that the product has been operated in accordance with the operation instructions and under normal conditions.

After the first year, with respect to this President's Lifetime Limited Warranty, NAPOLEON® may, at its discretion, fully discharge all obligations with respect to this warranty by refunding to the original warranted purchaser the wholesale price of any warranted but defective part(s).

NAPOLEON® will not be responsible for installation, labour or any other expenses related to the reinstallation of a warranted part and such expenses are not covered by this warranty.

Notwithstanding any provisions contained in the President's Lifetime Limited Warranty, NAPOLEON'S responsibility under this warranty is defined as above and it shall not in any event extend to any incidental, consequential or indirect damages.

This warranty defines the obligations and liability of NAPOLEON® with respect to the NAPOLEON® gas appliance and any other warranties expressed or implied with respect to this product, its components or accessories are excluded.

NAPOLEON® neither assumes, nor authorizes any third party to assume, on its behalf, any other liabilities with respect to the sale of this product.

NAPOLEON® will not be responsible for: over-firing, downdrafts, spillage caused by environmental conditions such as rooftops, buildings, nearby trees, hills, mountains, inadequate vents or ventilation, excessive venting configurations, insufficient makeup air, or negative air pressures which may or may not be caused by mechanical systems such as exhaust fans, furnaces, clothes dryers, etc.

Any damages to the appliance, combustion chamber, heat exchanger, plated trim or other components due to water, weather damage, long periods of dampness, condensation, damaging chemicals or cleaners will not be the responsibility of NAPOLEON®.

All parts replaced under the President's Limited Lifetime Warranty Policy are subject to a single claim.

During the first 10 years NAPOLEON® will replace or repair the defective parts covered by the lifetime warranty at our discretion free of charge. From 10 years to life, NAPOLEON® will provide replacement parts at 50% of the current retail price.

All parts replaced under the warranty will be covered for a period of 90 days from the date of their installation.

The manufacturer may require that defective parts or products be returned or that digital pictures be provided to support the claim. Returned products are to be shipped prepaid to the manufacturer for investigation. If a product is found to be defective, the manufacturer will repair or replace such defect.

Before shipping your appliance or defective components, your dealer must obtain an authorization number. Any merchandise shipped without authorization will be refused and returned to sender.

Shipping costs are not covered under this warranty.

Additional service fees may apply if you are seeking warranty service from a dealer.

Warranty labour allowance is only for the replacement of the warranted part. Travel, diagnostic tests, shipping and other related charges are not covered by this warranty.

ALL SPECIFICATIONS AND DESIGNS ARE SUBJECT TO CHANGE WITHOUT PRIOR NOTICE DUE TO ON-GOING PRODUCT IMPROVEMENTS. NAPOLEON® IS A REGISTERED TRADEMARK OF WOLF STEEL LTD.



Other products available from your
Authorized Napoleon® Fireplace Dealer...



Patio Heaters



Fireplace Mantels



HVAC Products



Electric Fireplaces



Outdoor Living Products



Fireplace Accessories

Contact your Authorized Napoleon® dealer or visit napoleonfireplaces.com for more information.