

# GAS GRILL ASSEMBLY, USE AND CARE MANUAL

MODEL : #GD4838S-G

Distributor's: Vanston Inc.

## WARNING

Improper installation, adjustment, alteration, service or maintenance can cause injury or property damage.

Read this instruction manual thoroughly before installing or servicing this equipment.

## WARNING

1. Do not store or use gasoline or other flammable vapors and liquids in the vicinity of this or any other appliance.
2. An LP tank not connected for use should not be stored in the vicinity of this or any other appliance.

## DANGER

If you smell gas:

1. Shut off gas to the appliance.
2. Extinguish any open flames.
3. Open the lid.
4. If the odor continues, keep away from the appliance and immediately call your gas supplier or fire department.

## WARNING

For Outdoor Use Only

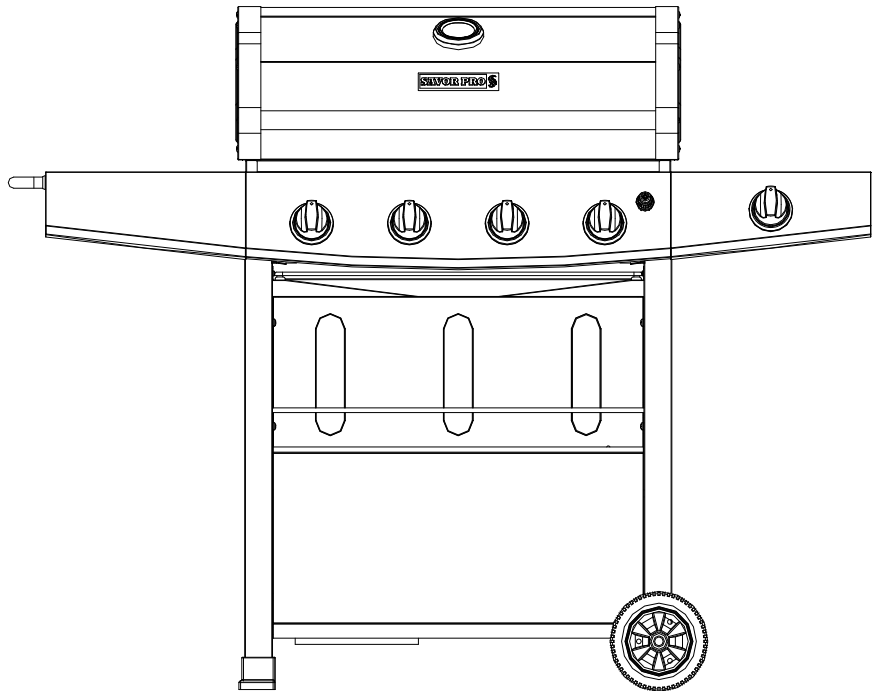

# GAS GRILL ASSEMBLY, USE AND CARE MANUAL

## TABLE OF CONTENTS

Safety Information	-----	3
Package Contents	-----	5
Hardware Contents	-----	7
Preparation	-----	7
Assembly Instructions	-----	8
Installation Instructions	-----	19
Operating Instructions	-----	23
Care and Maintenance	-----	27
Troubleshooting	-----	32
Warranty	-----	34

## **! SAFETY INFORMATION**

**Please read and understand this entire manual before attempting to assemble, operate or install the product. If you have any questions regarding the product, please call customer service at 1-800-963-0211, 8 a.m.-6 p.m., EST, Monday-Thursday, 8 a.m.-5 p.m., EST, Friday.**

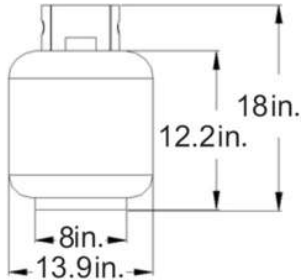
- The installation of this appliance must conform with local codes or, in the absence of local codes, with the National Fuel Gas Code, ANSI Z221.3/NFPA 54.
- This grill is intended for use outdoors and should not be used in a building, garage or any other enclosed or covered area.
- This outdoor grill is not intended for installation in or on recreation vehicles and/or boats.
- A minimum clearance of 36 inches from combustible constructions to the sides of the grill and 36 inches from the back of the grill to combustible constructions must be maintained. This outdoor cooking gas appliance must not be placed under overhead combustible construction.
- The use of an electrical source requires that when installed, the grill must be electrically grounded in accordance with local codes or in the absence of local codes, with ANSI/NFPA 70, or the Canadian Electrical Code, CSA C22.1. Keep electrical supply cords and the fuel supply hose away from heated surfaces.
- Inspect the hoses before each use for excessive abrasion or wear, or cuts that may affect safe operation of the grill. If there is evidence of excessive abrasion or wear, or the fact that the hose is cut, it must be replaced prior to the grill being put into operation. The replacement hose assembly must be those specified by the manufacturer.
- Keep your grill in an area clear and free from combustible materials, gasoline and other flammable vapors and liquids.
- DO NOT obstruct the flow of combustion and ventilation air to this appliance.
- Keep the ventilation openings of the tank enclosure free and clear of debris.
- Check all gas connections for leaks with a soapy water solution and brush. Never use an open flame to check for leaks.
- Never use charcoal in the grill.
- Never use the grill in windy areas.
- Only a 20 lb. LP-gas cylinder is allowed. The cylinder must be constructed and marked in accordance with the Specifications for LP Gas Cylinders of the U.S. Department of Transportation (D.O.T.) or the National Standard of Canada, CAN/CSA-B339, Cylinders, Spheres and Tubes for Transportation of Dangerous Goods; and Commission. Dimensions for a 20 lb. LP-Gas cylinder are:
- Never use the grill without the drip tray installed and hung under the burner box. Without the drip tray, hot grease and debris could leak downward and produce a fire hazard.
- Use only the gas pressure regulator supplied with this appliance. This regulator is set for an outlet pressure of 11.0 wc.
- The cylinder used must include a collar to protect the cylinder valve.
- Do not store a spare LP-gas cylinder under or near this appliance.
- Never fill the cylinder beyond 80 percent full.
- The regulator and hose assembly must be routed through the left leg assembly. Regulator must be locked with regulator hose lock before connect with LP tank. See page 18 for detailed assembly instructions.

## SAFETY INFORMATION

---

- **DANGER:** If the information in above is not followed exactly, a fire causing death or serious injury may occur.
- The outdoor cooking gas appliance must be isolated from the gas supply piping system by closing its individual manual shutoff valve during any pressure testing of the gas supply system at test pressures equal to or less than 1/2 PSI (3.5 KPa).
- **CALIFORNIA PROPOSITION 65 WARNING:** The burning of gas cooking fuel generates some byproducts which are on the list of substances known by the State of California to cause cancer, reproductive harm, or other birth defects. To reduce exposure to these substances, always operate this unit according to the use and care manual, ensuring you provide good ventilation when cooking with gas.

**IMPORTANT:** We urge you to read this manual carefully and follow the recommendations enclosed. This will ensure you receive the most enjoyable and trouble-free operation of your new gas grill. We also advise you retain this manual for future reference.

---

**WARNING:** Your grill has been designed to operate using only the gas specified by the manufacturer on the rating plate. Do not attempt to operate your grill with other gases. Failure to follow this warning could lead to a fire hazard and bodily harm and will void your warranty.

---

**WARNING:** Make certain your LP (propane) tank is filled by a reputable propane dealer. An incorrectly filled or overfilled LP tank can be dangerous. An overfilled tank combined with the warming of the LP tank (a hot summer day, tank left in the sun, etc.) can cause LP gas to be released by the pressure relief valve on the tank since the temperature increase causes the propane to expand. LP gas released from the tank is flammable and can be explosive. Refer to your Owner's Manual for more information concerning filling your LP tank.

The installer must hand the instructions to the consumer and the consumer should retain them for future reference.

If the outdoor cooking gas appliance is not in use, the gas must be turned off at the supply cylinder(s). Storage of an outdoor cooking gas appliance indoors is permissible only if the cylinder(s) is (are) disconnected and removed from the outdoor cooking gas appliance. Cylinders must be stored outdoors out of the reach of children and must not be stored in a building, garage, or any other enclosed area.

# Package Contents

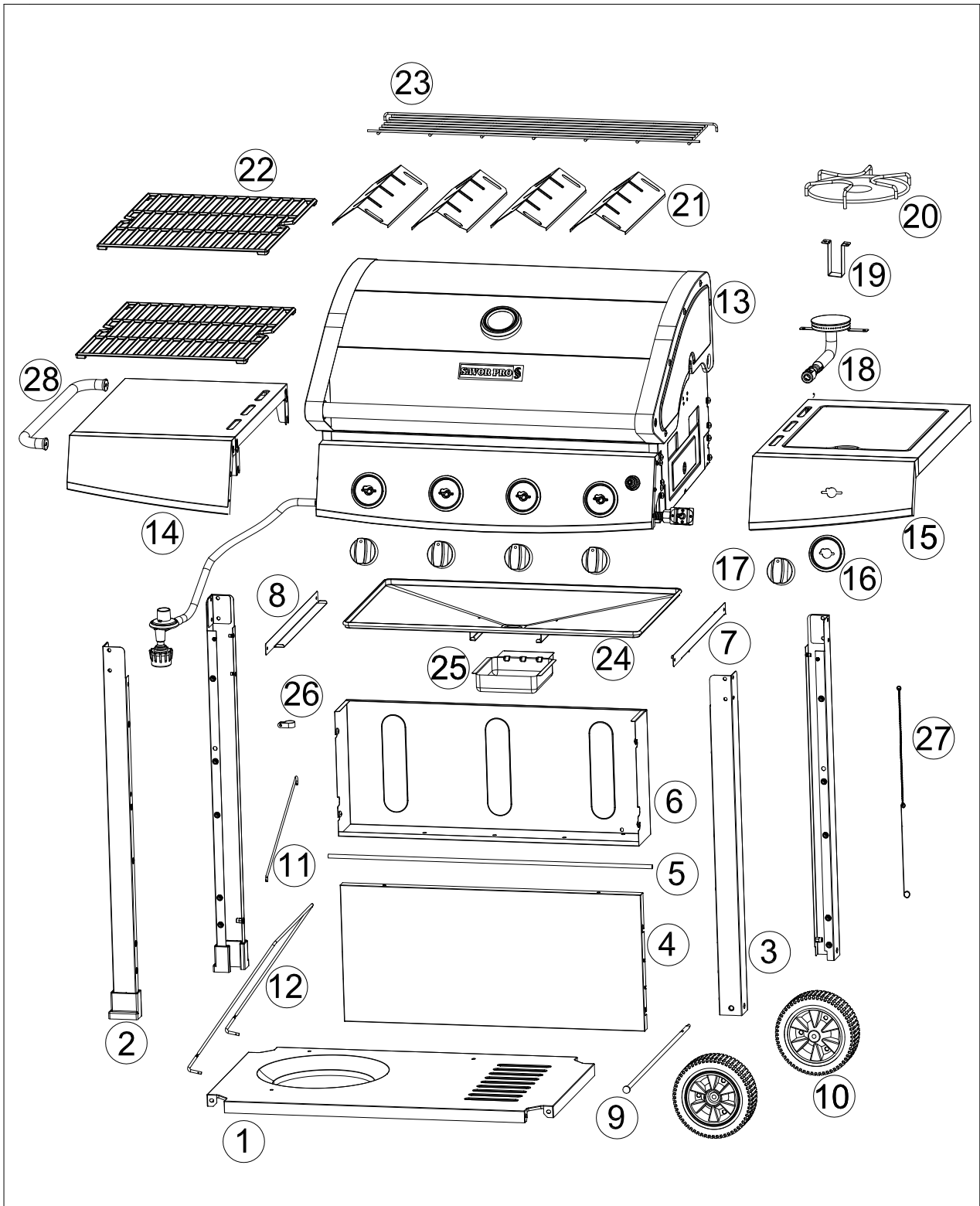

# Package Contents

---

Part	Description	Quantity
1	Bottom Panel	1
2	Left Leg Assembly	2
3	Right Leg Assembly	2
4	Front Panel	1
5	Stay Rod for condiment tray	1
6	Condiment Tray	1
7	Drip tray bracket right	1
8	Drip tray bracket left	1
9	Axle	1
10	Wheel	2
11	Cylinder stop rod	1
12	Gas Cylinder Safety Stop	1
13	Firebox and Hood Assembly	1
14	Left Side Table	1

Part	Description	Quantity
15	Right Side Burner Table	1
16	Knob Bezel	1
17	Knob	5
18	Side Burner	1
19	Side Burner holder	1
20	Side Burner Grid	1
21	Heat Tent	4
22	Cooking Grate	1
23	Warming Rack	1
24	Drip Tray	1
25	Grease Cup	1
26	Regulator Hose Lock	1
27	Matchstick Holder Assy	1
28	Side Table Handle	1

# Hardware Contents

---

A



M6 Nut  
Qty. 1

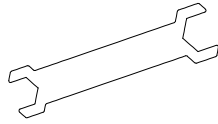

Small Spanner  
Qty. 1

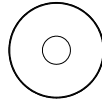

Axle Washer  
Qty. 1

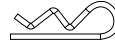

R Pin  
Qty. 4



Axle Mat  
Qty. 1

B



M6 x 12  
Screw  
Qty. 16



M6  
Lock Washer  
Qty. 16

C



M4 x 8  
Screw  
Qty. 10

D



M4 x 12  
Screw  
Qty. 1

E



M6 x 16  
Screw  
Qty. 9



M6  
Lock Washer  
Qty. 9

## PREPARATION

---

Before beginning assembly of product, make sure all parts are present. Compare parts with package contents list and hardware contents list. If any part is missing or damaged, do not attempt to assemble the product.

**Tools required for assembly(not included):Phillips Screwdriver,Wrench.**

# Assembly Instructions

## 1. Attach the four legs to bottom panel

Using 2-M6x12 screws, secure left leg assembly (part 2) to bottom panel (part 1) and right leg assembly (part 3) with corresponding screws, Insert the stay rod for condiment tray (part 5) into the mounting holes on left leg assembly and right leg assembly. Assemble 2 additional legs in same manner (see illustration below).

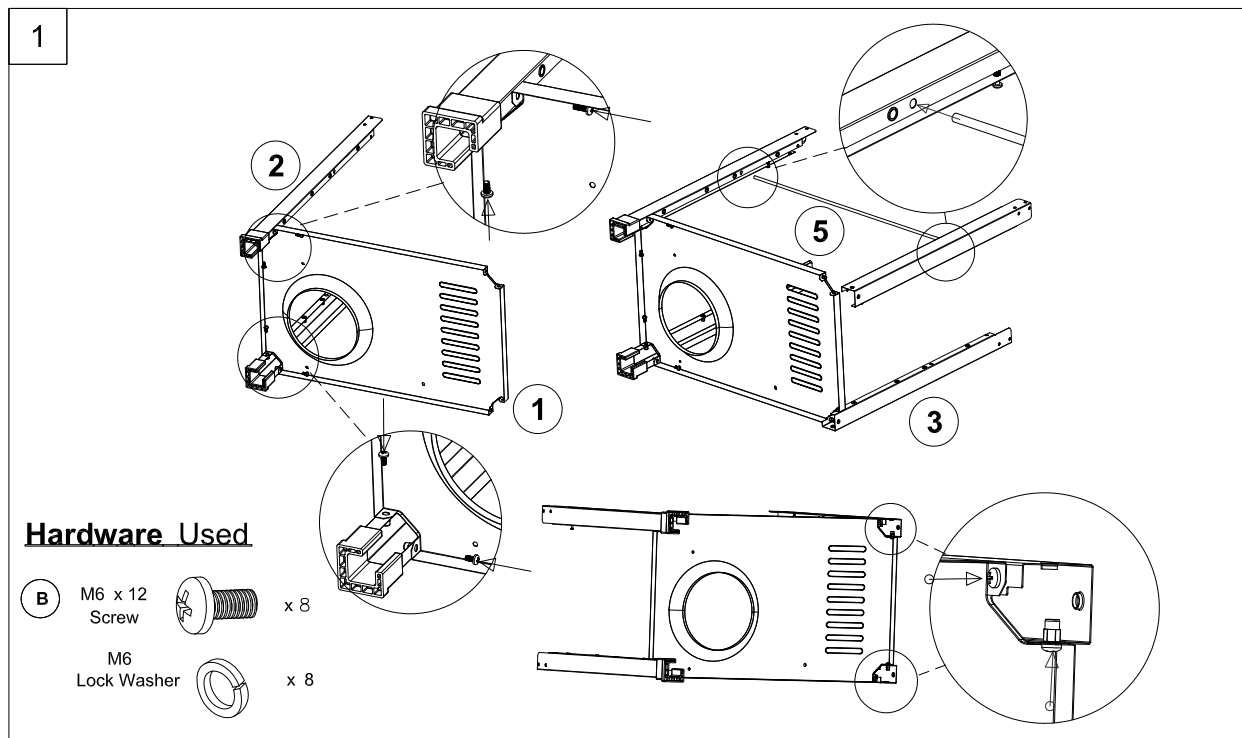

## 2. Install the Front Panel

Insert the corresponding M6x12 screws with M6 lock washers into the pre drilled holes in lower portion of the left and right legs located at the front of the cart. Do not tighten screws. Line up the slots in the front panel (part 4) to the screws. Slide the front panel into place. Tighten the 4 screws.

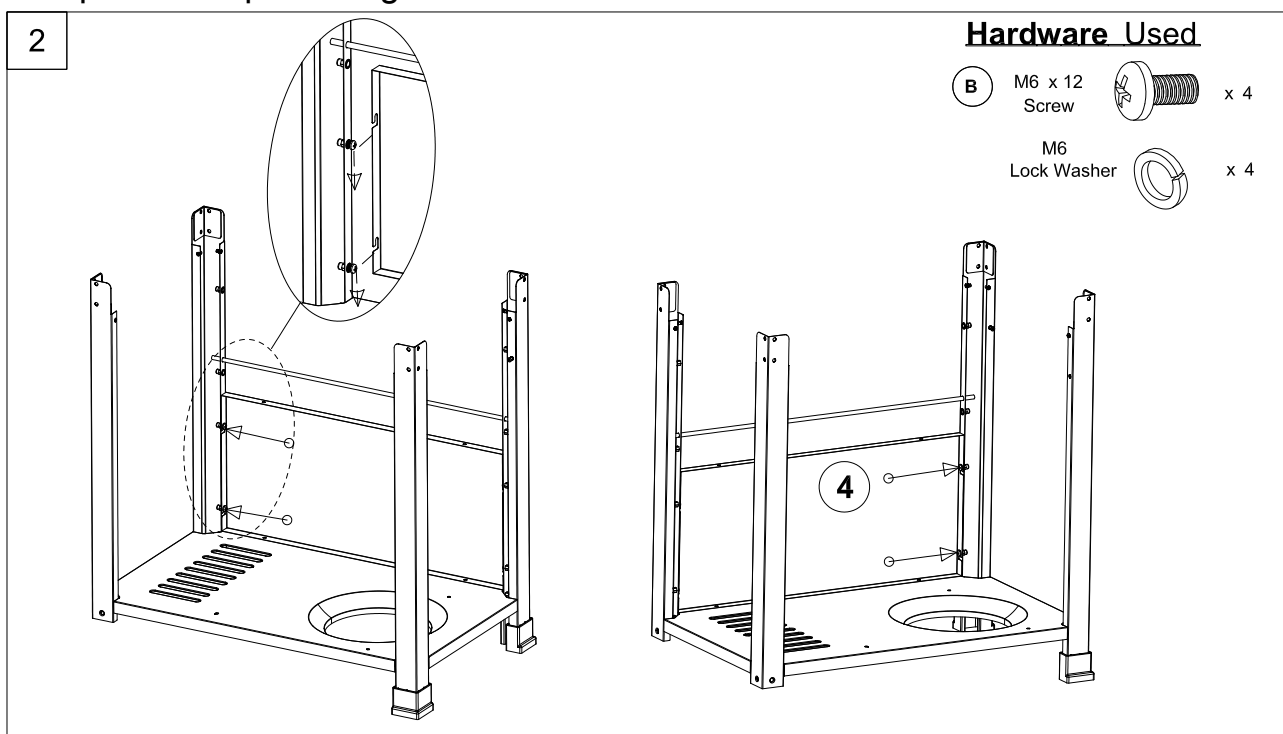



# Assembly Instructions

## 3. Install the Condiment Tray

Insert 4 M6X12 screws with 4 M6 lock washers into the pre drilled holes in the upper portion of the front legs of the cart. Do not tighten screws. Line up the slotted holes in the condiment tray (part 6) to the screws. Slide the condiment tray into place. Tighten the screws.

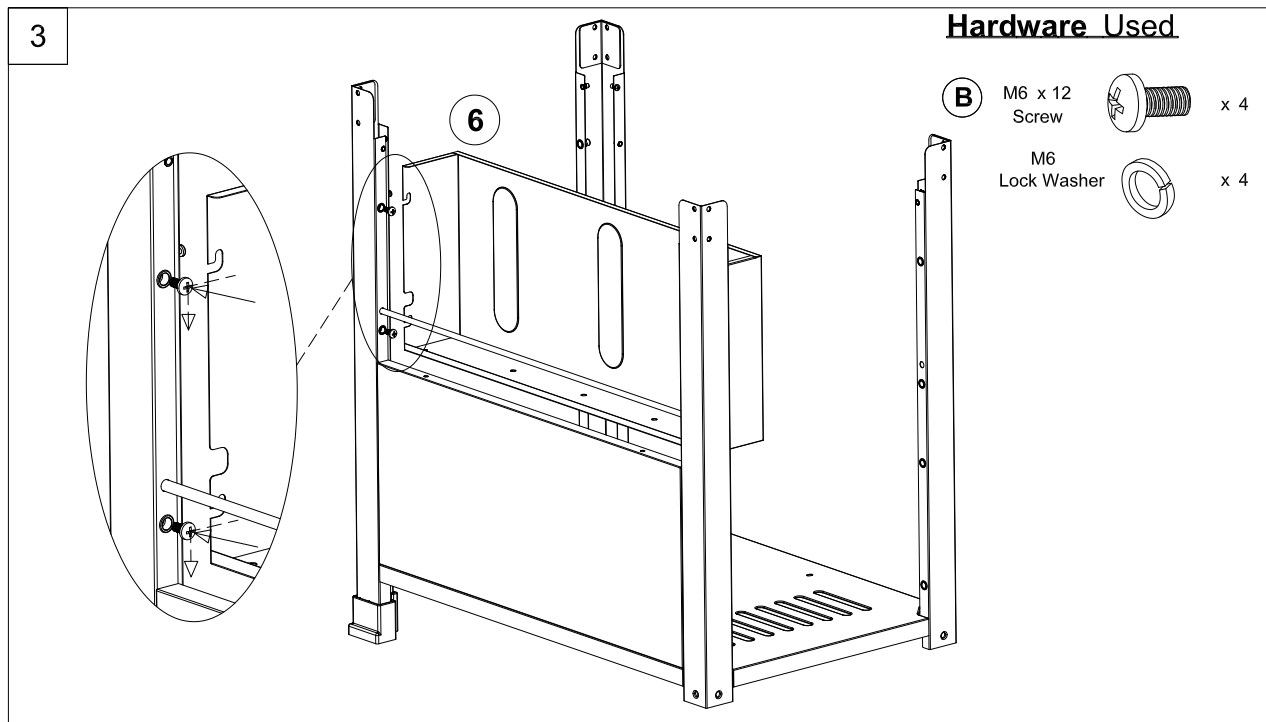

## 4. Install the Wheel

Insert the axle (part 9) into the wheel (part 10) and then into axle mat. Insert the axle into the predrilled hole located on the right front leg of the cart (see illustration below). The axle will then insert into coordinating hole in the cart leg at the back of the cart. Insert the additional wheel on the axle on the back side of the cart. Insert the axle washer on the axle and secure with the M6 lock nut. There is a small wrench included.

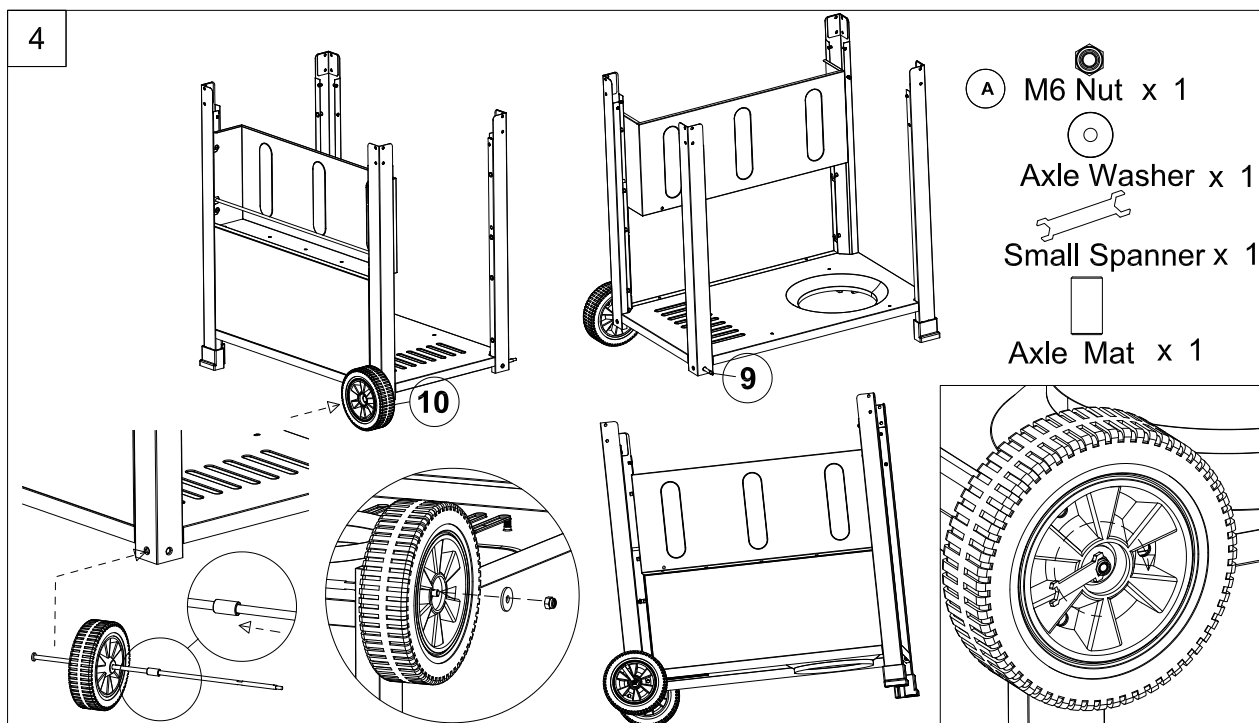

# Assembly Instructions

## 5. Install left and right drip tray brackets

Lock the drip tray bracket left (part 8) and drip tray bracket right (part 7) into the mounting hole at left and right leg assembly with corresponding M4x8 screws.

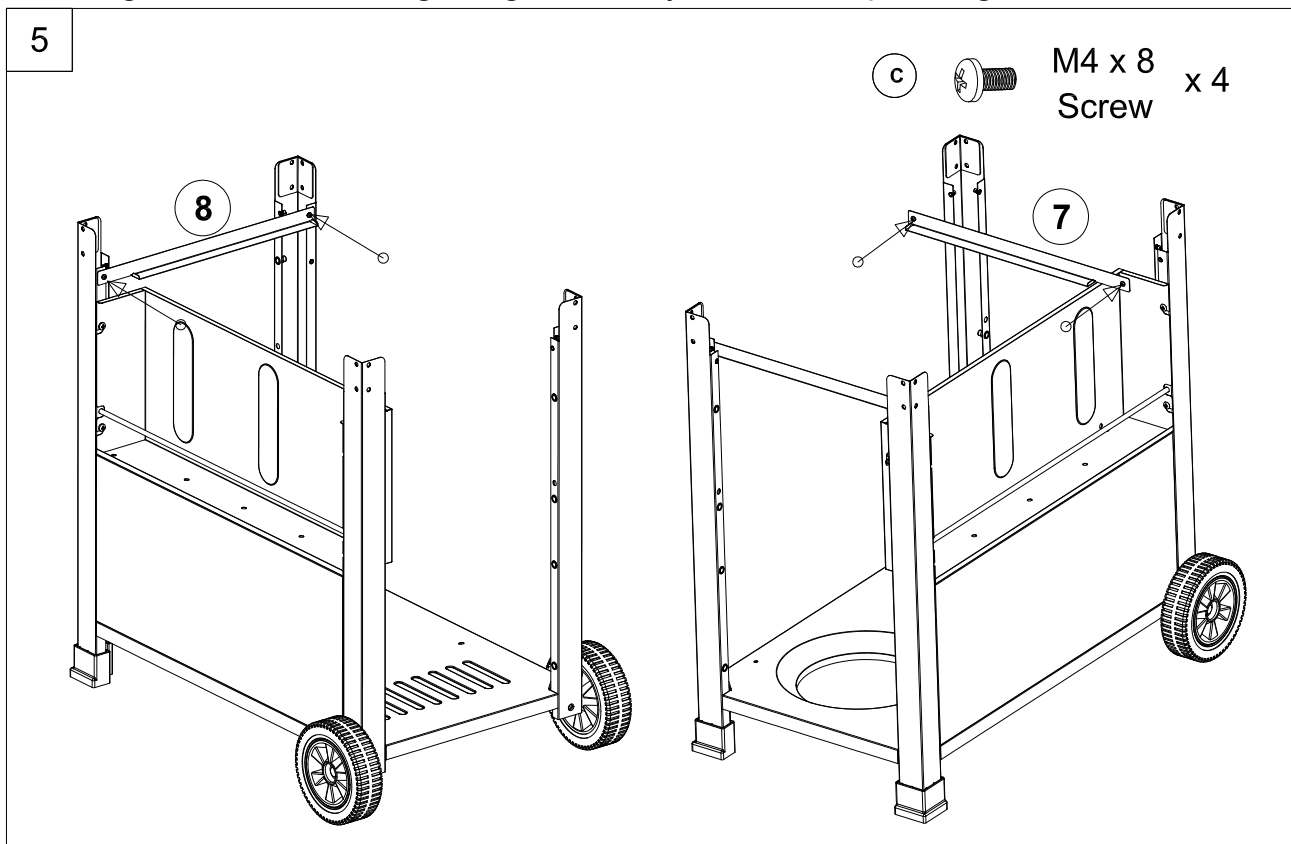

## 6. Install the cylinder stop rod and gas cylinder safety stop

Place the cylinder stop rod (part 11) in the mounting hole at condiment tray and predrill hole in bottom panel. Place the gas cylinder safety stop (part 12) in the predrilled holes in bottom panel (see illustration below). Insert R pins into the predrilled hole at the tip of the cylinder stop rod inserted through hole in condiment tray (see illustration below).

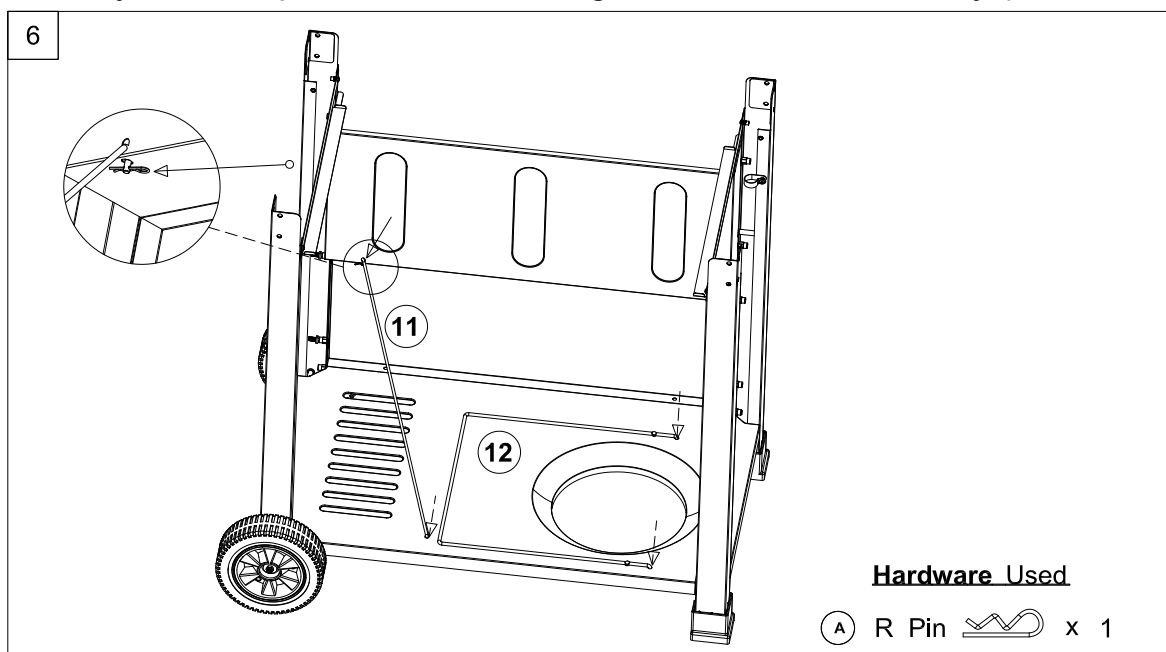

# Assembly Instructions

## 7. Install the R pin at Cylinder stop rod and Gas Cylinder Safety Stop

Lay cart on its side. Install three R pins in the pre drilled holes in the tips of the cylinder stop rod (part 11) and gas cylinder safety stop (part 12). Set cart upright.

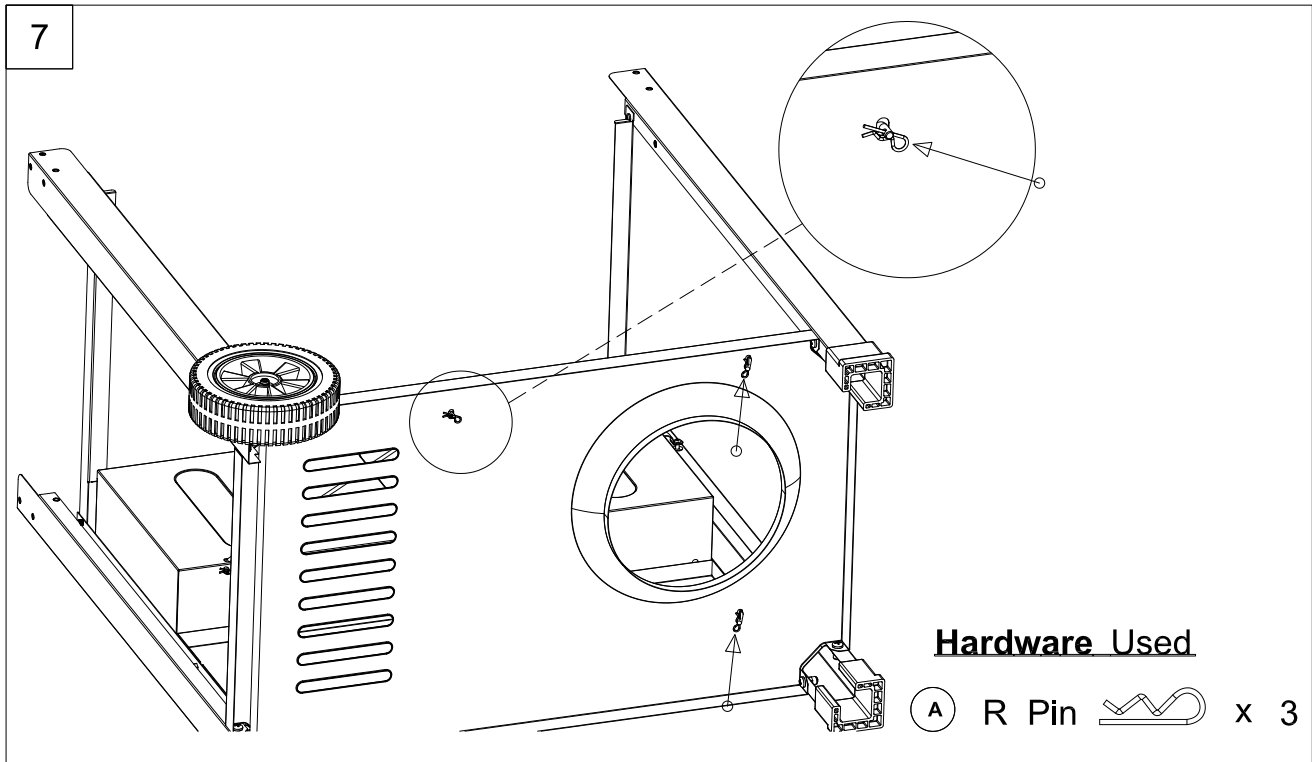

## 8. Install the firebox and hood assembly

Place the knob (part 17) on the valve stem (see illustration below). Set the firebox and hood assembly (part 13) on top of the cart panel. Secure the firebox and hood assembly with 2 M6x16 screws and 2 M6 washers at the top of each leg of the cart (see illustration below).

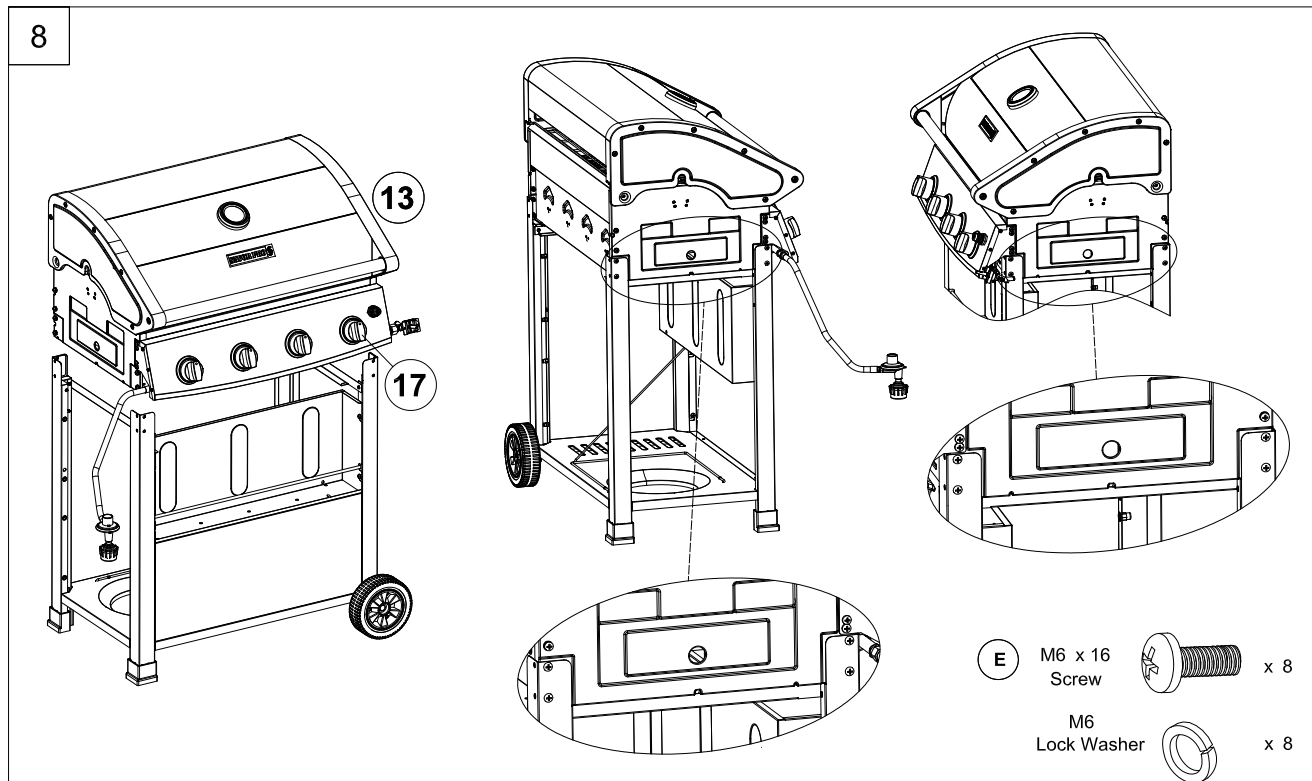

# Assembly Instructions

## 9. Install side table handle

Unscrew the pre-installed screws on the handle, then put the screws through the holes on the side of side table, connect them to the handle (part 28), and tighten the screws (2).

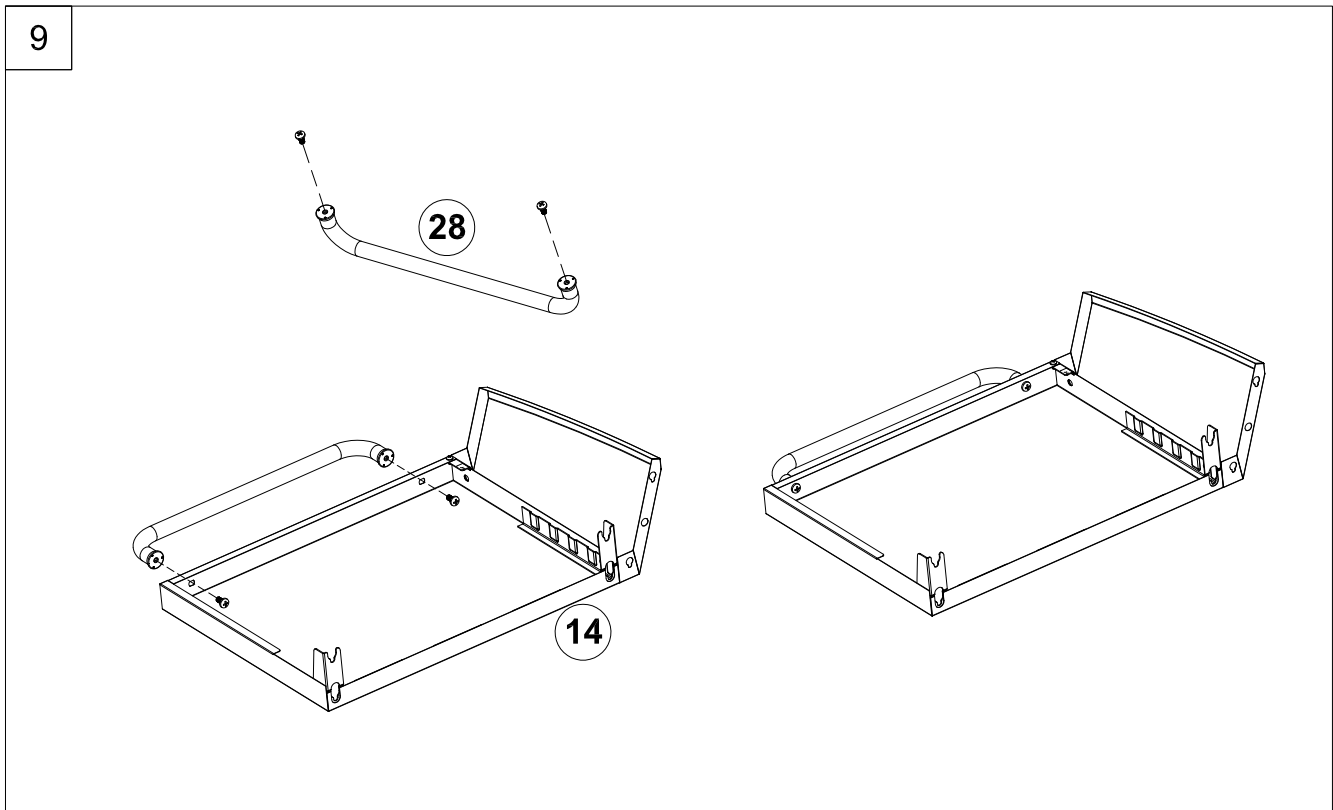

## 10. Install the left side table

Line up the holes in the left side table (part 14) with the pre-installed screws on left side of the firebox and hood assembly. Slide left side table into place over the screws. Tighten the pre-installed screws to secure the side table.

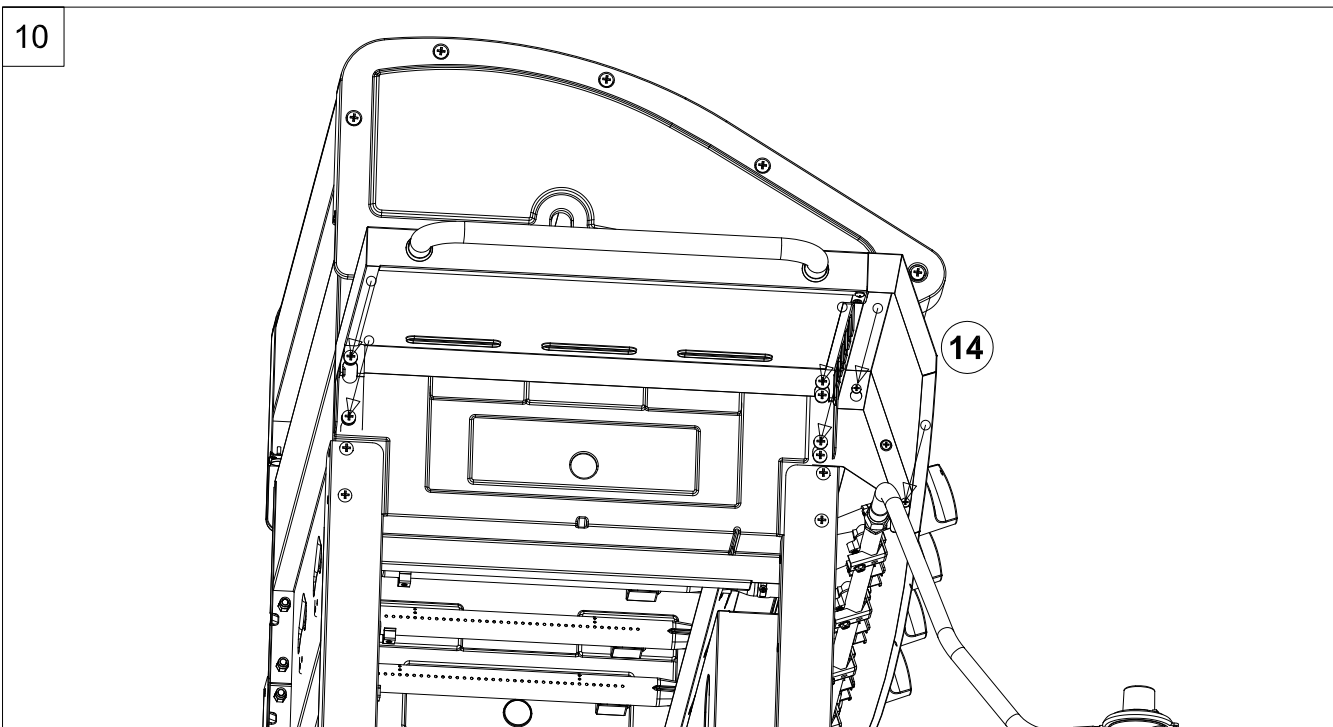

# Assembly Instructions

## 11. Install the right side burner table

Line up the holes in the right side table (part 15) with the pre-installed screws on right side of firebox and hood assembly. Slide right side table into place over the screws. Tighten the pre-installed screws to secure the side table.

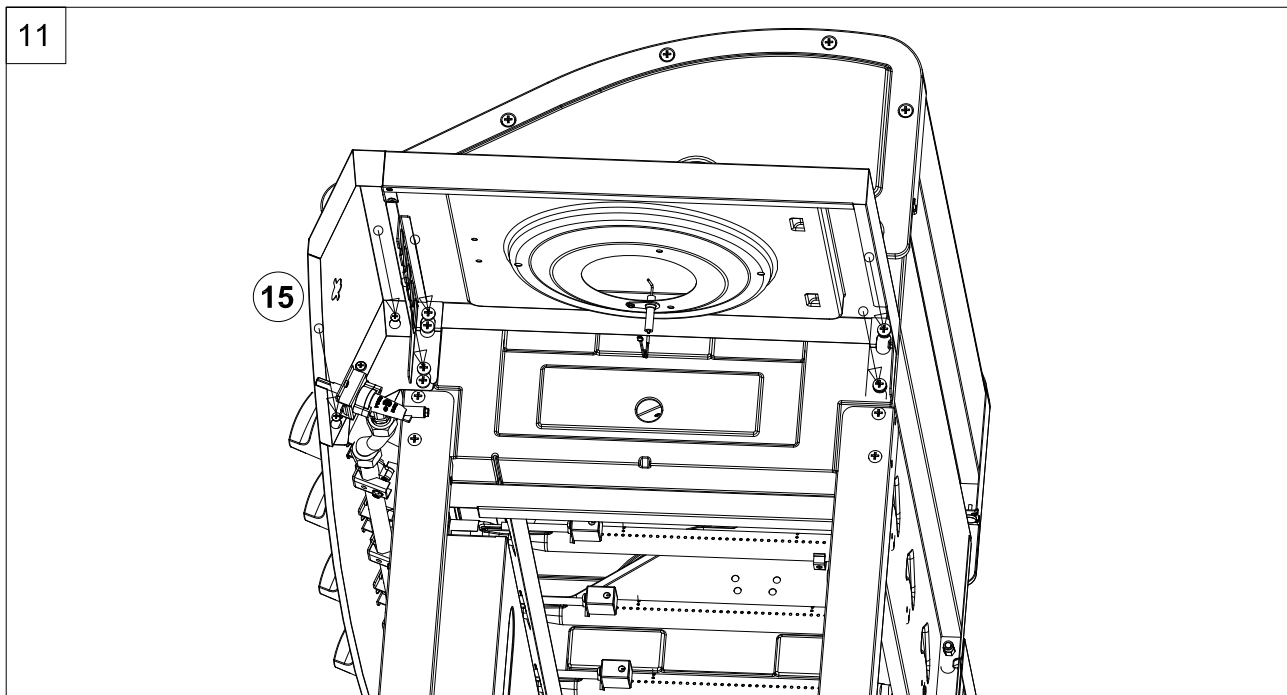

## 12. Install the knob bezel and side burner gas line

As shown in figure below, line up the holes in the side burner valve bracket to the holes in the back side of the right side table front panel. Hold in place with one hand. On the front side of the side table front panel line up the holes of the bezel (part 16) with the holes in the front panel. Hold the bezel with the thumb of the hand holding the side burner valve in place. Using free hand insert M4x8 screws into holes in bezel securing bezel and side burner control valve. Tighten screws.

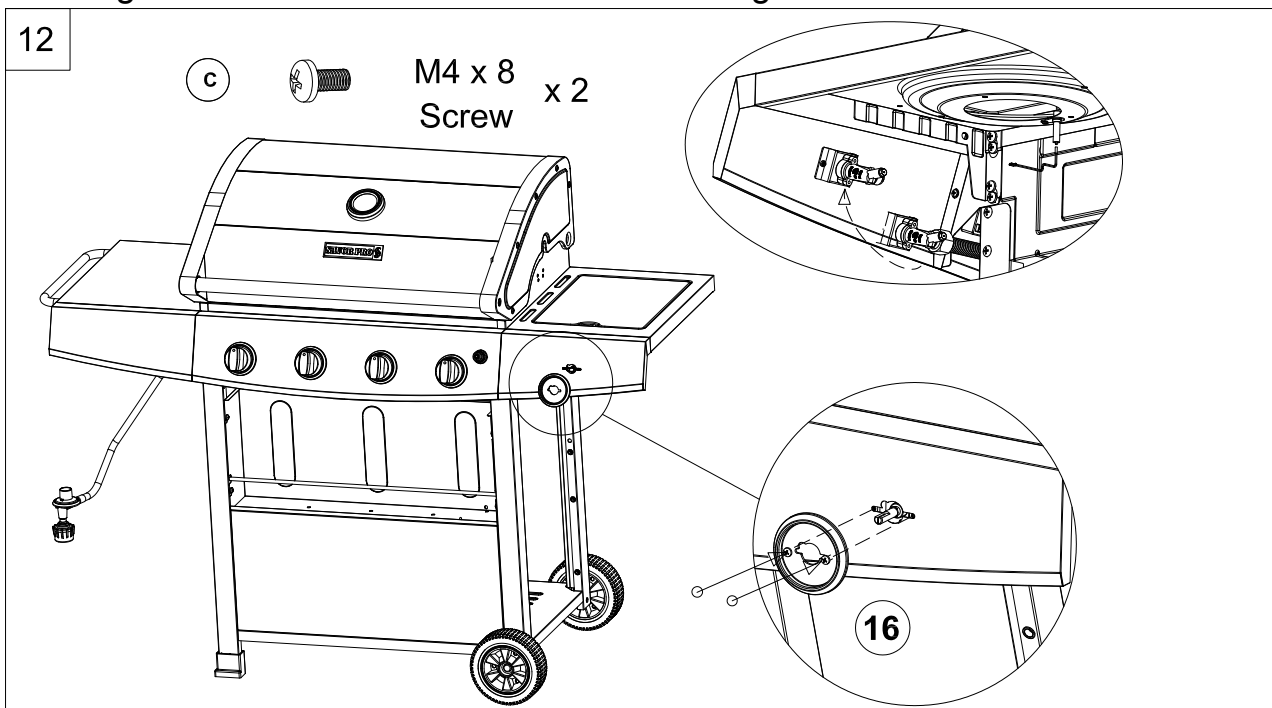

# Assembly Instructions

## 13. Install side burner

Place side burner through the hole in the top of the right side table. Insert the open end of side burner (part 18) over the outlet end of side burner valve (see illustration below). Center the hole in the side burner over the outlet on the control valve (it is ok that the open part of the side burner is not sealed). Line up the holes in the side burner bracket to the holes in the top of the side table locking the side burner at the mounting hole of right side burner with corresponding screws. Mount the knob (part 17) on the side burner valve stem.

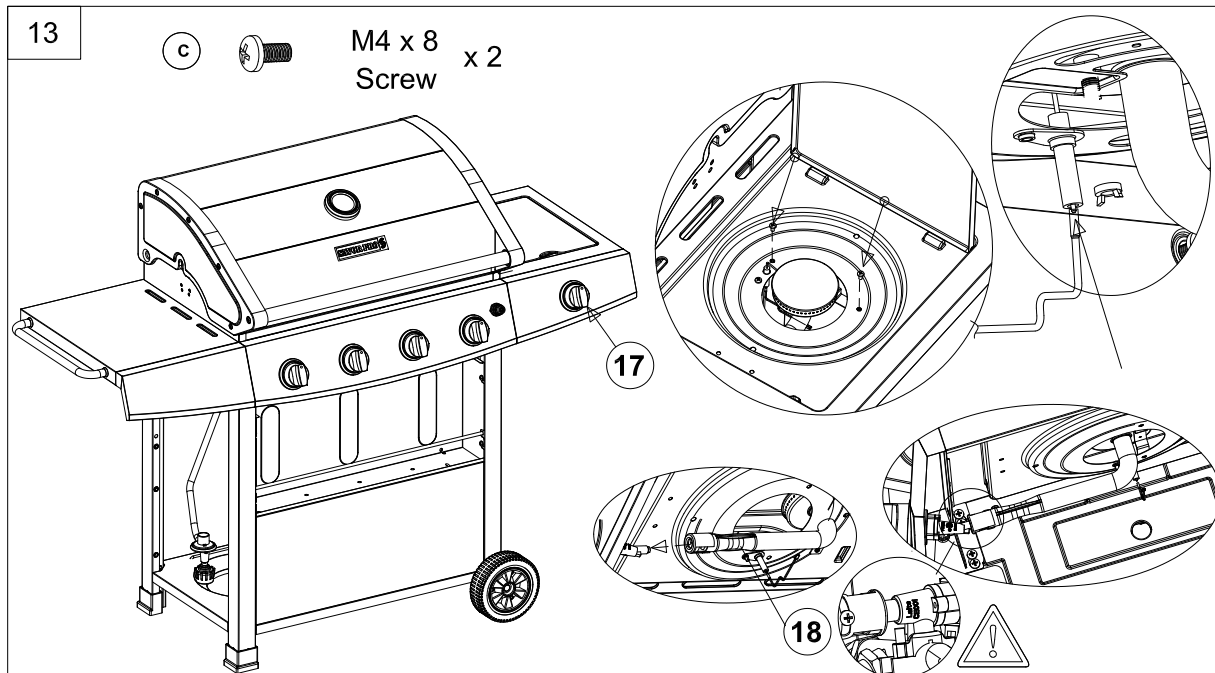

## 14. Install the side burner bracket

Line up the side burner bracket (part 19) to the pre drilled holes in side table, using 2-M4x8 screws. Secure the bracket to the side table (see illustration below).

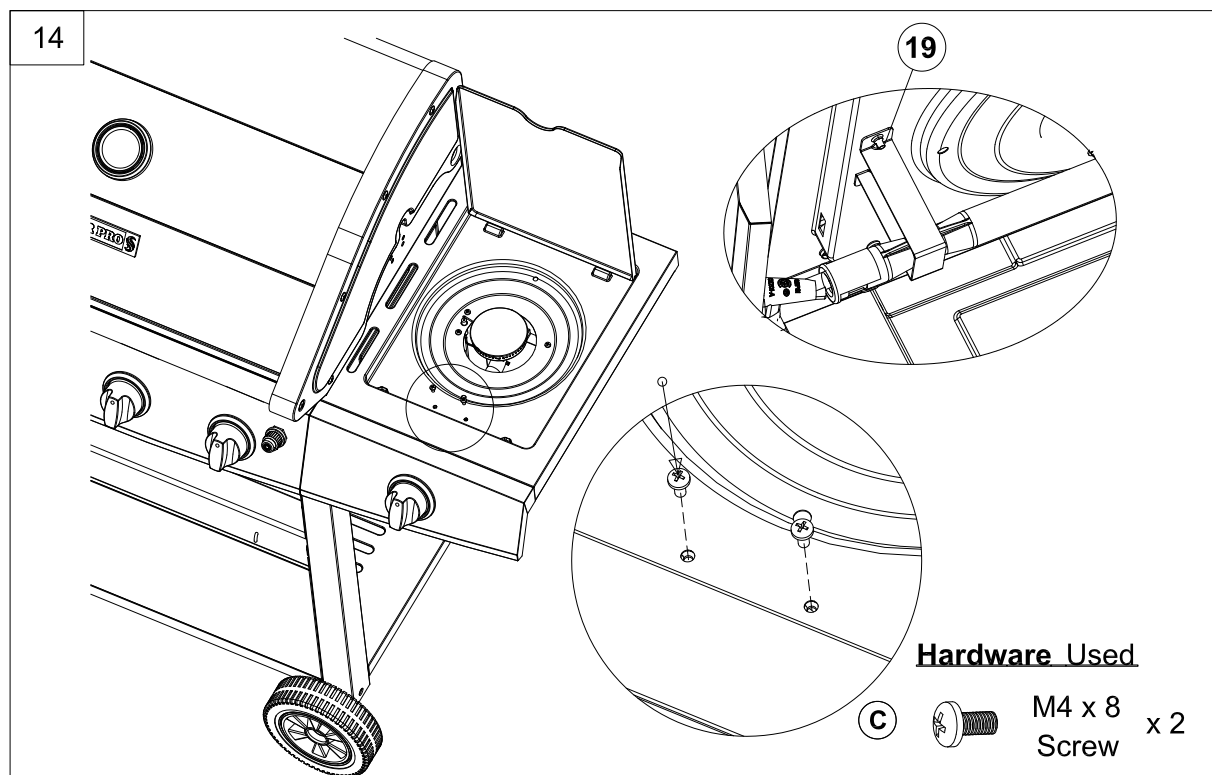

## Assembly Instructions

### 15. Install the side burner grate

Insert side burner grate (part 20) over the side burner making sure the tabs line up with corresponding holes (see illustration below).

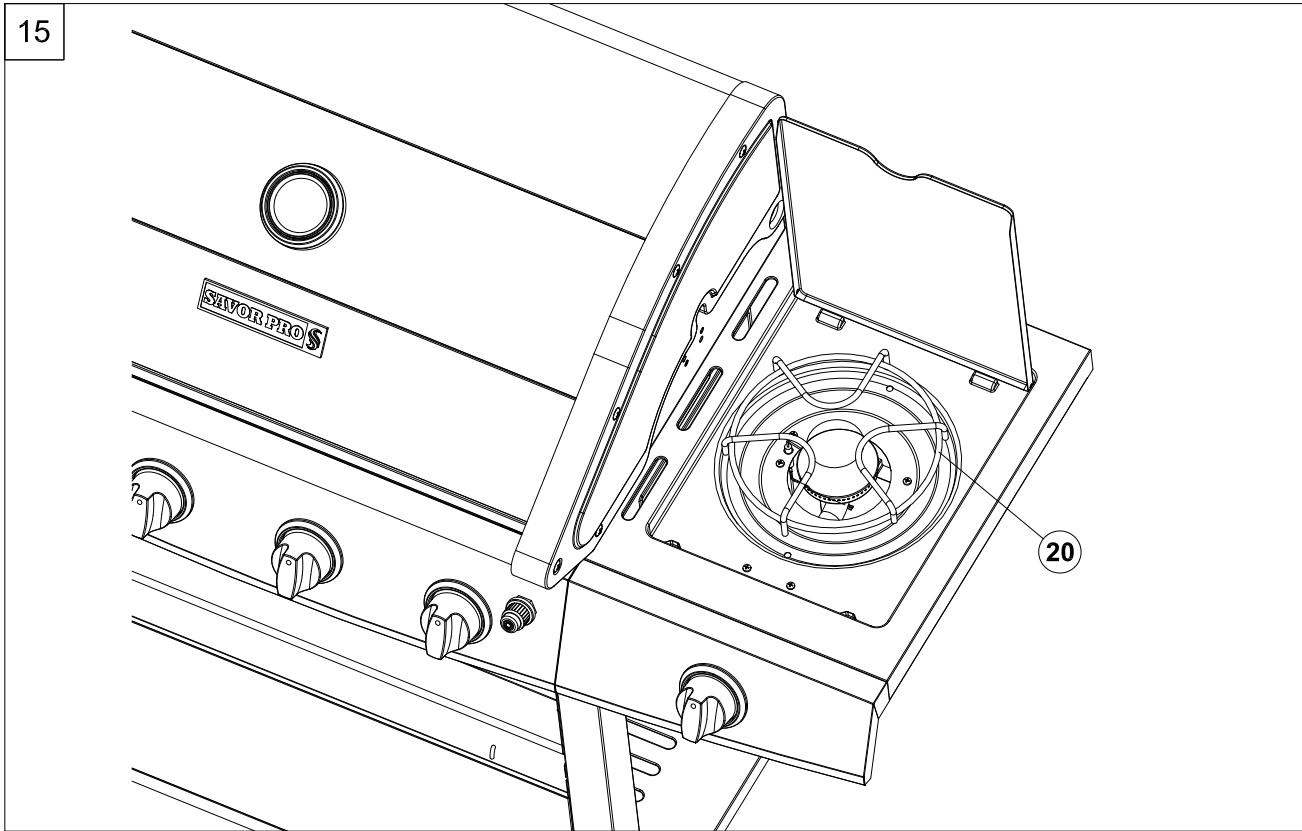

### 16. Install heat tents

Place the 4 heat tents (part 21) over each burner inside the firebox. Vented end of heat tent is placed toward the back of the firebox (see illustration below).

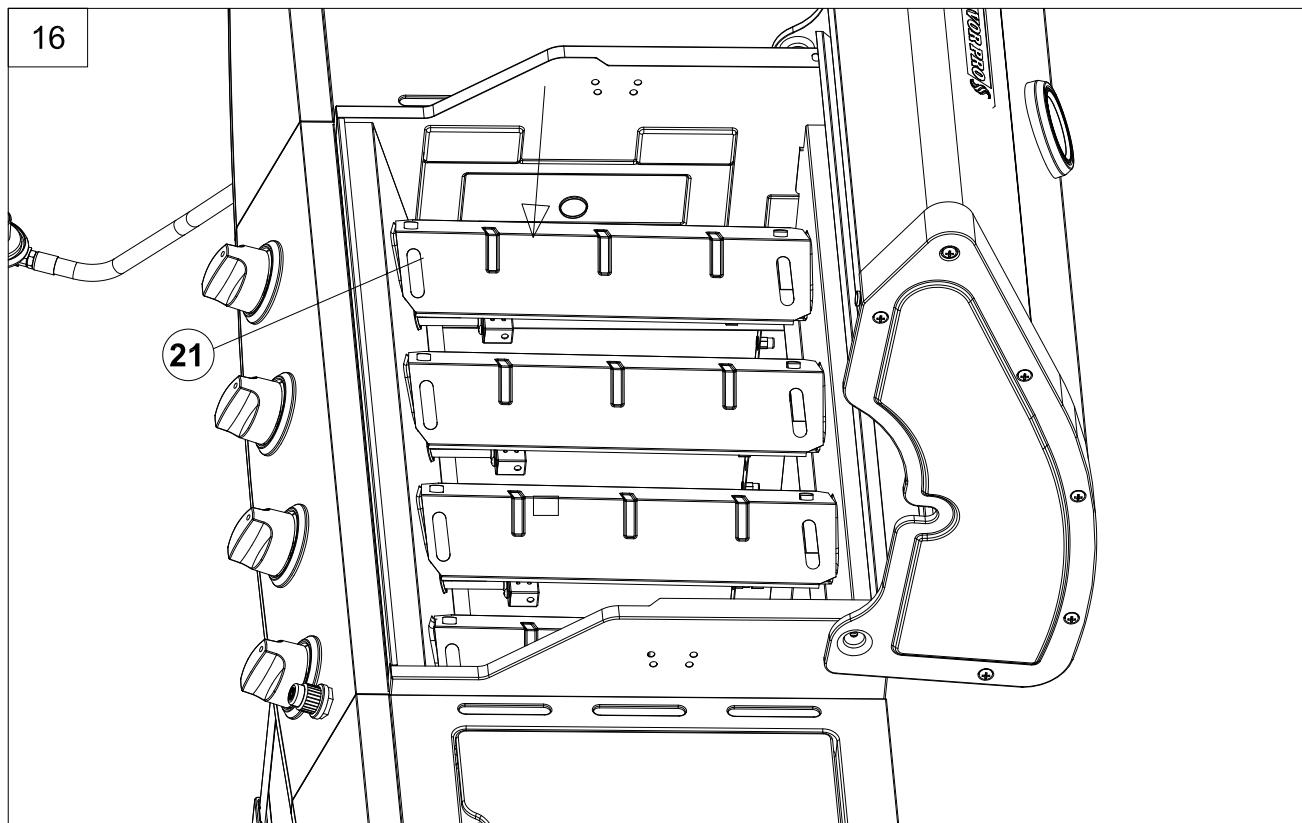

## Assembly Instructions

### 17. Install the cooking grate

Place the cast iron cooking grates (part 22) into the firebox. Grates are porcelain coated. Seasoning is not required.

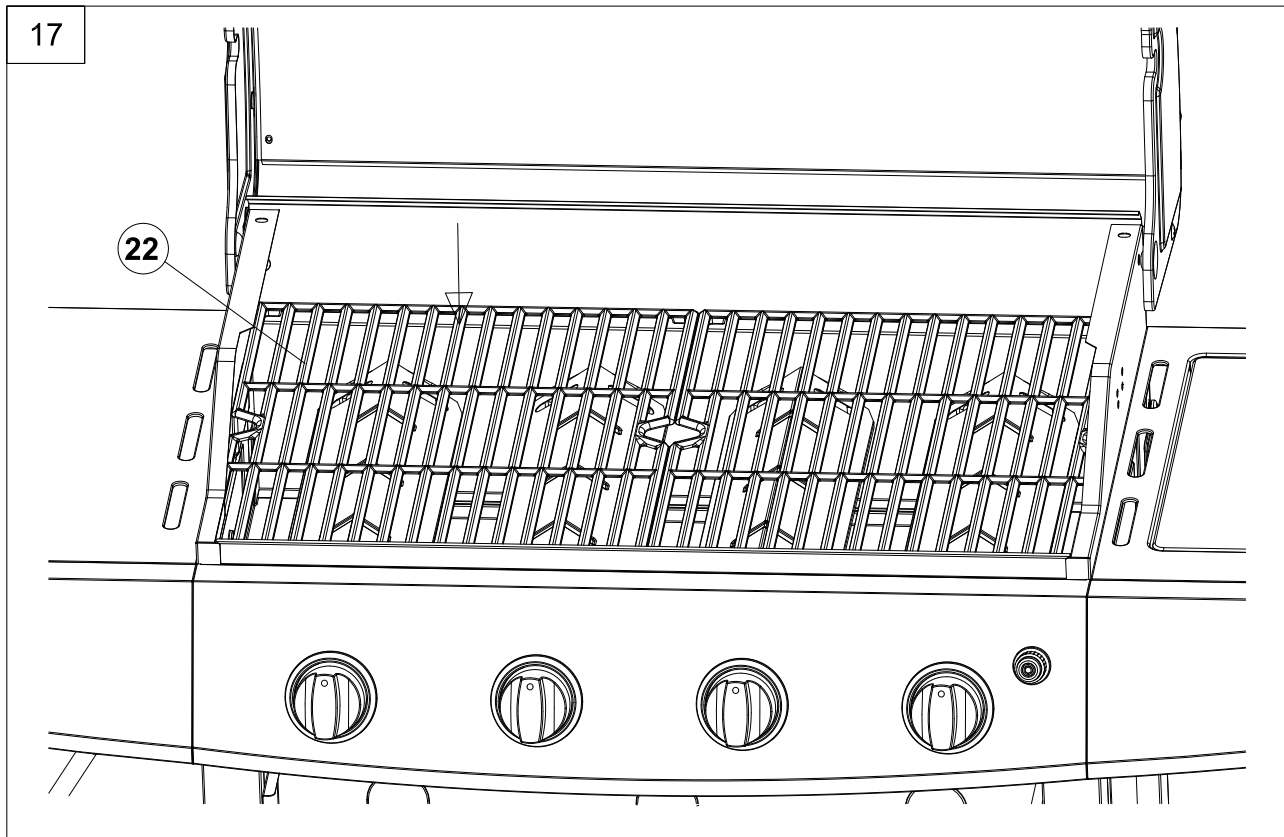

### 18. Install the warming rack

Insert warming rack (part 23) making sure the tabs on the warming rack fit into the pre-drilled holes in the firebox (see illustration below).

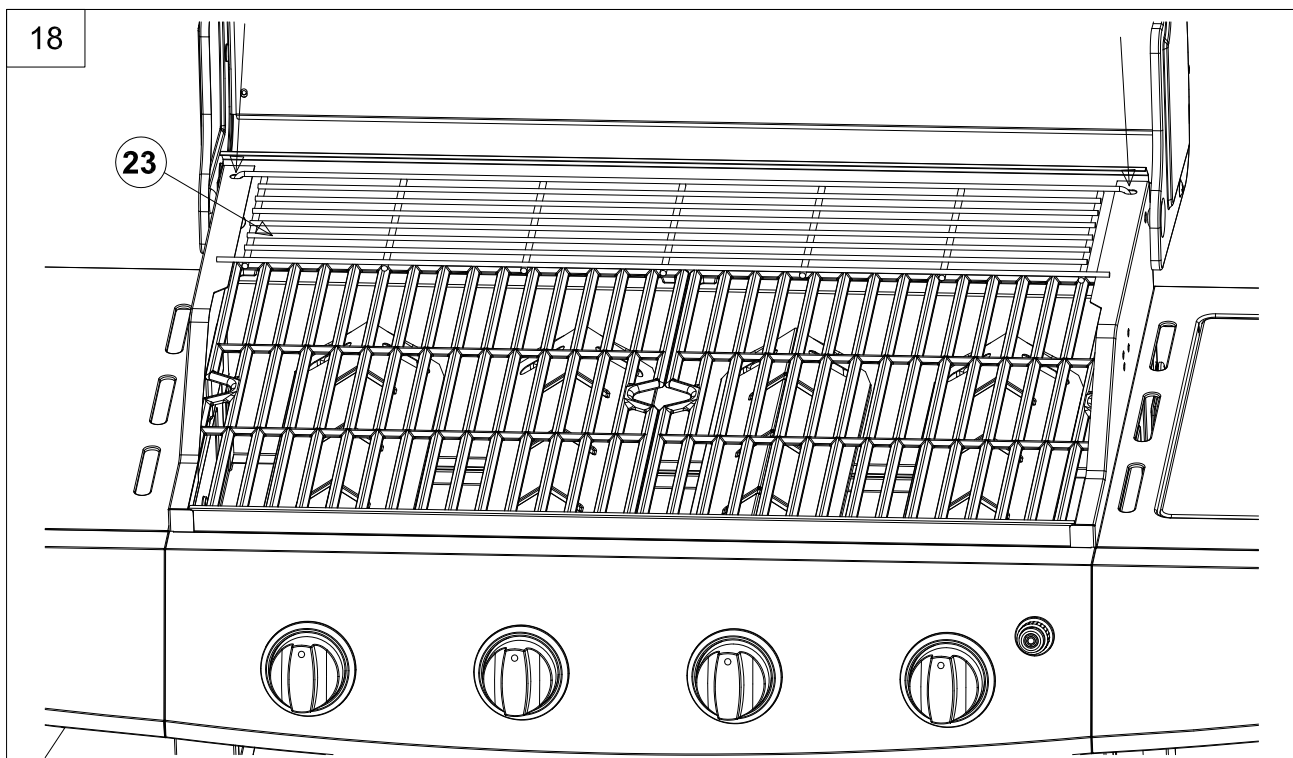



## Assembly Instructions

### 19. Install the drip tray and grease cup

Insert the drip tray (part 24) into the drip tray brackets from the back of the grill. Insert the grease cup (part 25) into the brackets on drip tray (see illustration below).

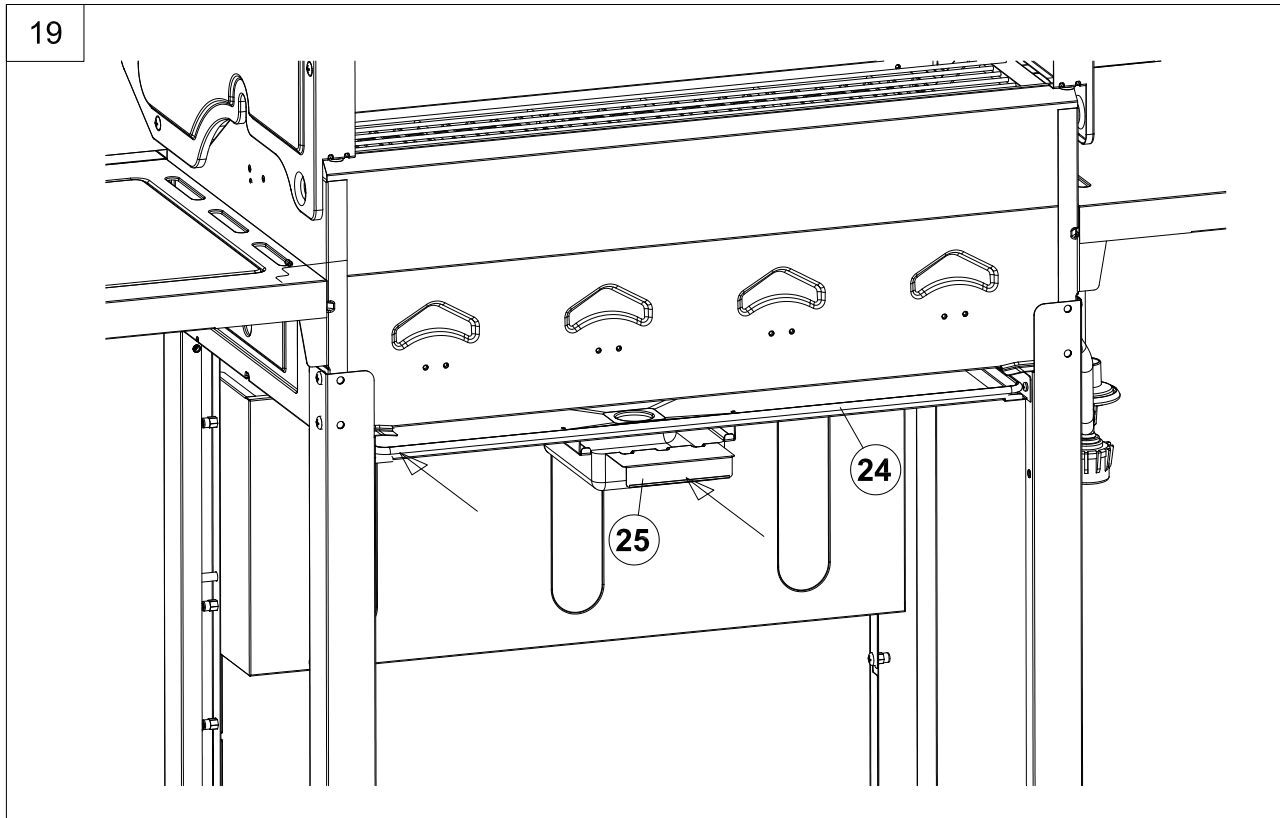

### 20. Secure regulator hose

Using clamp (part 26) and corresponding screw, secure the regulator hose to the right front leg of the cart using the pre drilled hole. This is a safety feature to make sure the regulator hose does not get too close to the drip tray (see illustration below for hole location).

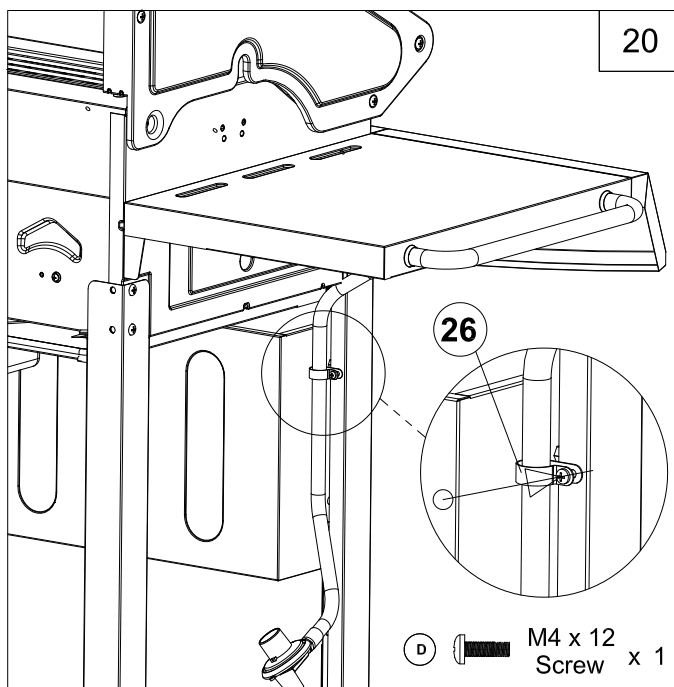

## Assembly Instructions

### 21. Install matchstick holder assy. and igniter battery

Locate screw at the 2/3 position of back left leg of cart. Do not tighten screw. Hang the single loop end of matchstick holder (part 27) onto the screw. You may also hang the top loop on the other end of the matchstick holder over the same screw (see illustration below). This is a safety feature for use when lighting with a standard match. Please use with caution.

Locate igniter button on front panel of grill. Unscrew the igniter button. Place AA battery inside the igniter negative end first. Make sure the spring is located inside the rubber boot of the igniter button. Screw igniter button back into place (see illustration below).

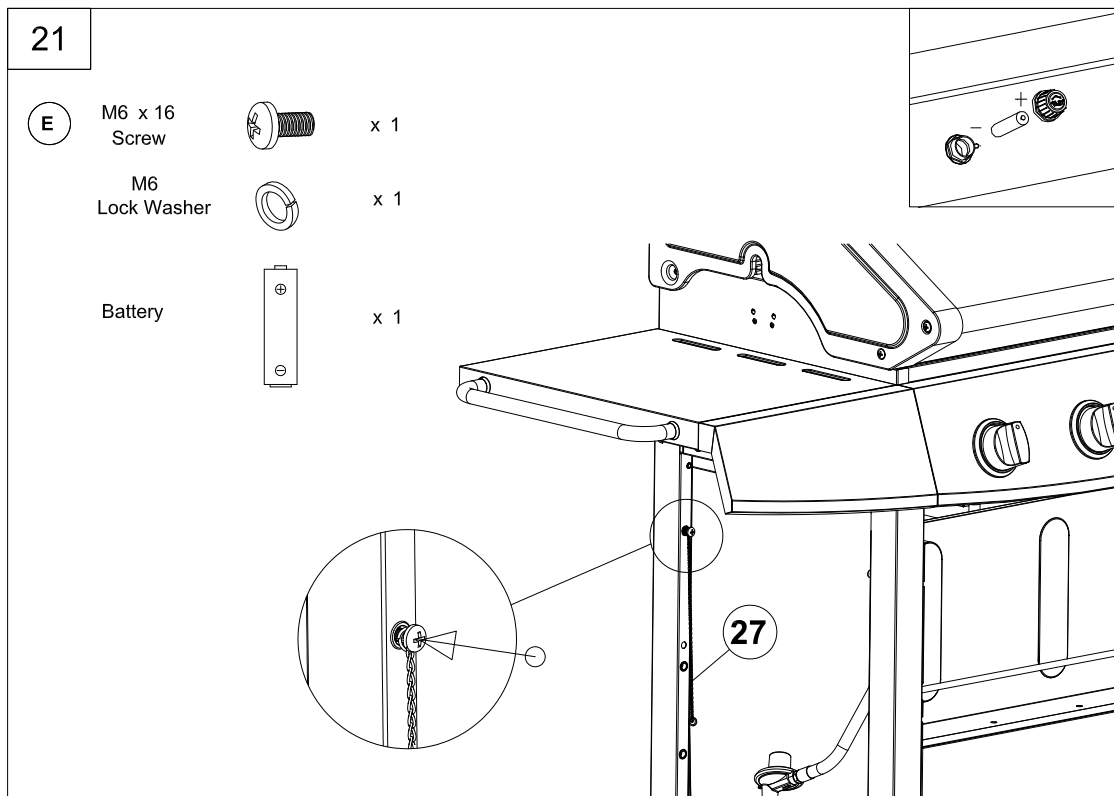

### 22. Install gas tank

Place 20 lb. LP tank (not included) into round opening in the bottom of cart. Secure tank using gas cylinder safety stop (P).

Connect regulator to tank and tighten by hand. Your grill is now ready for use.

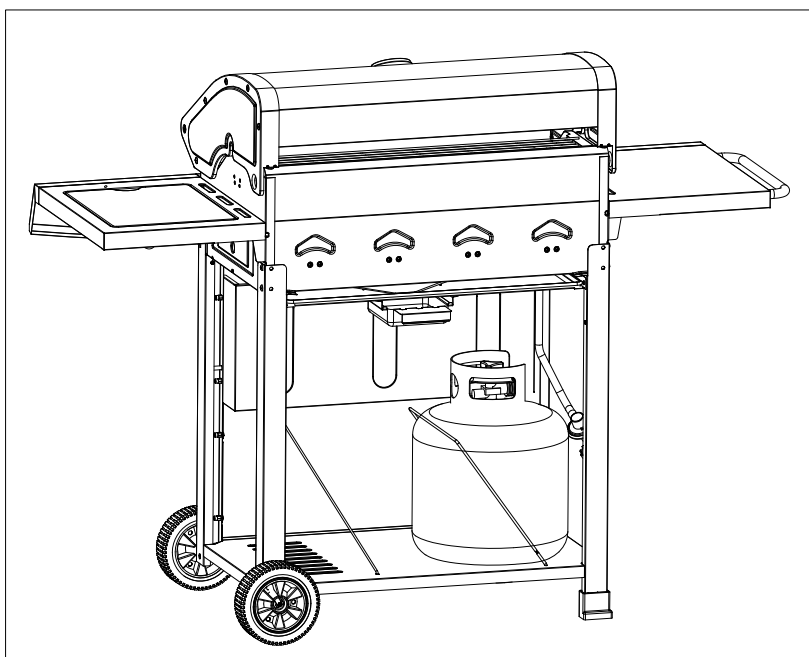

## **Assembly Instructions**

---

### **INCORRECT REGULATOR ASSEMBLY**

The regulator and hose should not be routed through the gap between the bottom of firebox and the top of cart. Incorrect assembly will result in loss of warranty. Incorrect assembly may cause gas leakage, fire and severe bodily harm. The regulator and hose assembly must be routed through the hole of the left side panel into the cart.

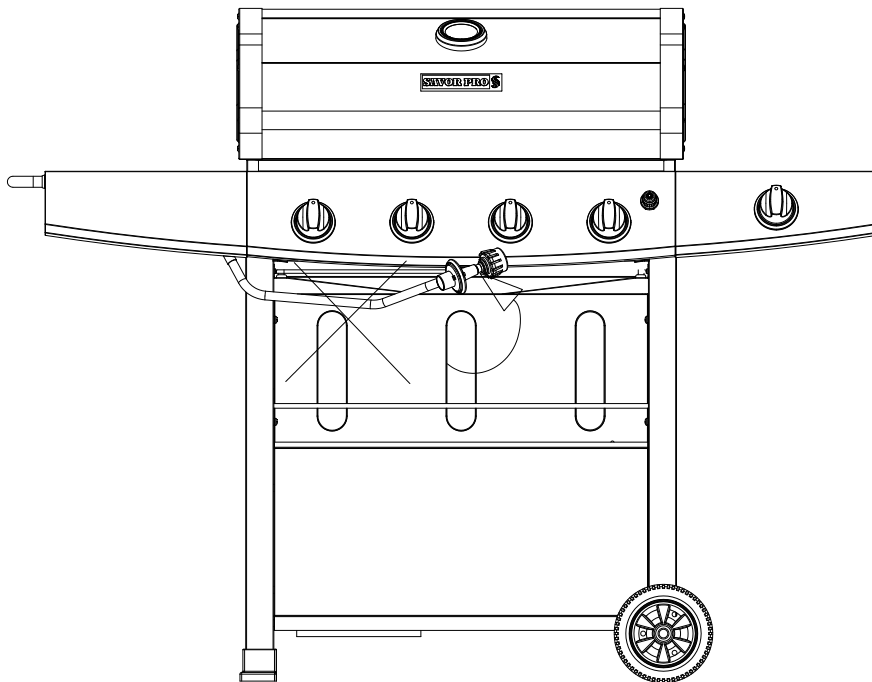

### **CHECK FOR SPARKS**

**After grill assembly is completed, test the ignition system with the GAS OFF. Check to make sure all igniters spark while pressing the ignition button.**

### **For Portable LP-Gas Connection**

The cabinet has an opening in the bottom panel that allows a 20 lb. gas tank bottom flange to drop into place (tank not included). This will help to lock the tank in place. After positioning the tank in the opening, lift up the gas cylinder safety stop to lock the tank (Fig. 21). Use only 20 lb. gas tank (See LP Gas Safety Requirements for additional information). As shown in Fig.22, it is unsafe to operate the grill if the gas tank is not vertical.

# Installation Instructions

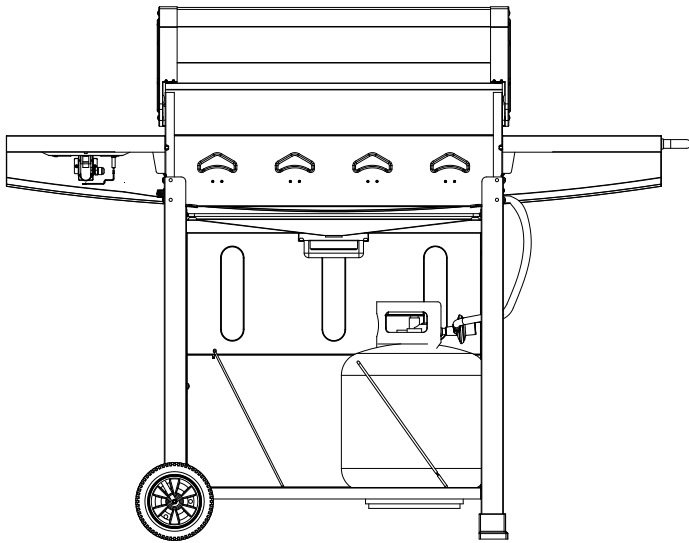

Fig. 22

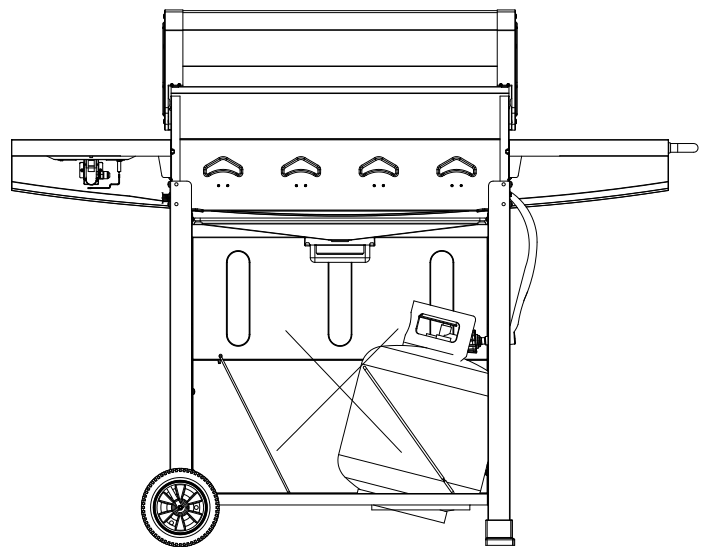

Fig. 23

**WARNING:** The Type I connective coupling (see Fig.24) supplied with your grill must not be replaced with a different type of grill/tank connection system. Removal will result in loss of warranty, gas leakage, fire and severe bodily harm.

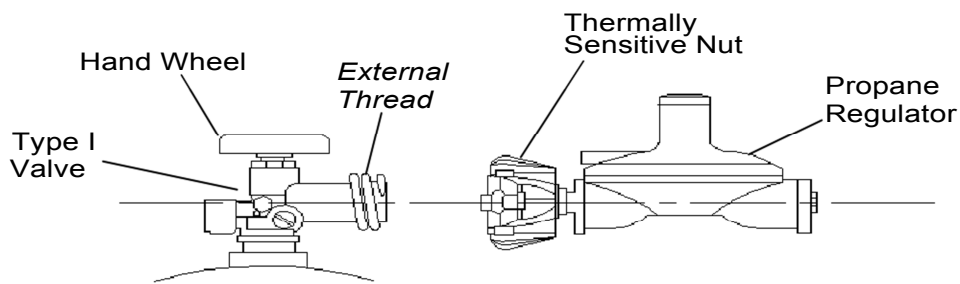

Fig.24

The propane tank valve connection supplied with this grill incorporates four important safe guards: Hand Assembly, Hand Disassembly, Excess Flow Control and Temperature-Activated Shut-Off.

## a. Hand Assembly:

1. Make certain the tank valve and all the appliance valves are in the “OFF” position.
2. When connecting the regulator valve assembly to the tank, turn the large plastic nut clockwise until it stops.
3. Gas will not flow unless the plastic nut is completely connected.
4. HAND TIGHTEN ONLY.

# Installation Instructions

---

## b. Hand Disassembly:

1. Make certain the tank valve and all the appliance valves are in the “OFF” position.
2. Turn the large plastic nut counter-clockwise until it is disassembled.
3. HAND LOOSEN ONLY.

## c. Excess Flow Control

The propane regulator assembly incorporates an excess flow device designed to supply the grill with sufficient gas flow under normal conditions yet control excess gas flow.

Rapid changes in pressure can trigger the excess flow device providing a low flame and low temperature. If the tank valve is turned open to allow gas flow while a burner valve is open, the surge of pressure will cause the device to activate. The device will remain closed until the pressure is equalized. This should occur within 5 seconds.

To ensure this does not cause difficulty in lighting the grill, follow these instructions:

1. Make sure all burner valves are “OFF”.
2. Open the tank valve and wait 5 seconds.

## d. Temperature-Activated Shut-Off

The large plastic nut on the regulator assembly is designed in coordination with a check valve in the tank valve to shut off the flow of gas when exposed to temperatures between 240-300° F. In the event of a fire or hose break, one of the safeguards will function to control or stop the flow of gas from the propane tank. Never attempt to use damaged equipment.

**IMPORTANT:** Before the use of a fresh tank of gas, please check leakage around the connections according to section “Checking Gas Leaks” on page 25 and make sure there is no leakage or vapor accumulation in the cabinet. Make sure all openings around side walls are not blocked.

**IMPORTANT:** Place dust cap on cylinder valve outlet whenever the cylinder is not in use. Only install the type of dust cap on the cylinder valve outlet that is provided with the cylinder valve. Other types of caps or plugs may result in leakage of propane.

## Gas Requirements

The grill is set and tested at the factory for use with LP-Gas only.

### LP Gas

The regulator supplied is set for 11 in. water column (WC) and is for use with LP gas only. The factory-supplied regulator and hose must be used with a 20 lb. LP gas tank.

# Installation Instructions

## LP GAS System

Contact your gas supplier for a special regulator for bulk gas that fuels other appliances.

## Gas Consumption

Total gas consumption of this grill with the burner(s) on “MAX” Table 1 below.

Table 1

<b>Burner Type</b>	<b>BTU/HR</b>
<b>Main Burners</b>	<b>12,000</b>
<b>Side Burner</b>	<b>12,000</b>

## **Locating the Grill**

This gas appliance is designed and certified for outdoor use only. Do not operate the grill inside a building, garage, recreation vehicle, screened porch or any enclosed area. Keep the grill away from windy areas, but keep the grill in a well-ventilated area. Do not obstruct the flow of combustion and ventilation air around the grill.

**Warning: Do not place the grill under overhead, unprotected combustible surfaces.**

## **Clearance to Combustible Construction**

A minimum clearance of 36 in. from the sides of the grill and a minimum clearance of 36 in. from the back of the grill to adjacent vertical combustible constructions must be maintained. However, the manufacturer strongly suggests a 6 ft. clearance of the grill to combustible constructions.

## **Clearance to Noncombustible Construction**

A minimum clearance of 36 in. from the back of the grill above the cooking surface to noncombustible constructions is required to allow the grill hood to open completely. A minimum of 36 in. clearance to the sides of the grill above the cooking surface to noncombustible constructions is recommended. The grill can be installed directly next to noncombustible construction below the cooking surface.

## **Checking orifice alignment with burners**

Orifices may shift during assembly and movement; therefore, check the orifice alignment with the burners according to the following illustrations before lighting.

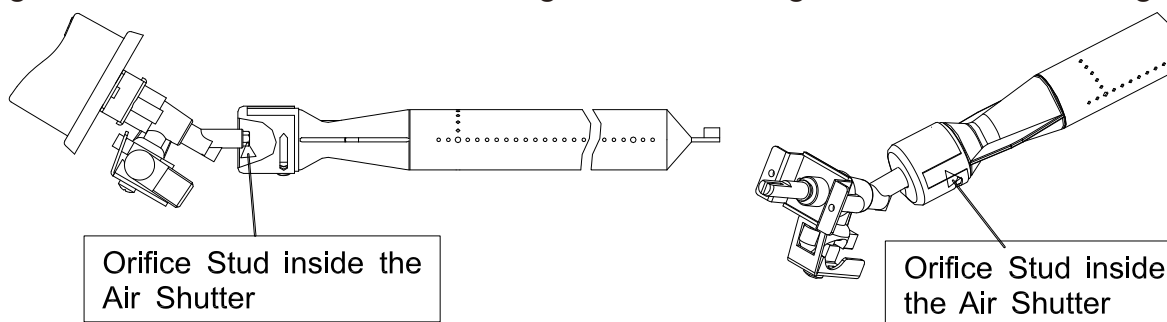

Fig. 25 Main Burner and Orifice Relationship

# OPERATING INSTRUCTIONS

---

## Grill Lighting Instructions

### To Light the Main Burners

- 1 .Make sure the control knobs are in the “OFF” position.
- 2 .Open the grill hood.
- 3 .Check the ignition pin position and distance between the pin and the burner. Refer to Step 14 of the Assembly Instructions.
- 4 .Make sure the drip tray is installed.
- 5 .Open the LPG tank.
- 6 .Light each burner separately. Turning on two burner valves together could trip the flow connection (LP grills only).
- 7 .Push the control knob in and turn the knob to the left to “MAX” position. Keep pressing the knob until the burner is lit.
- 8 .If the burner does not ignite within 5 seconds, immediately turn the control knob back to the “OFF” position. Wait 5 minutes and repeat Step 7 up to 2 or 3 times.
- 9 .If the burner still does not ignite, **TURN OFF THE GAS. WAIT 5 MINUTES** for excess gas to dissipate. Repeat Steps 6 and 7(if necessary).
- 10 . If the burner still can't be lit, refer to the Troubleshooting section.

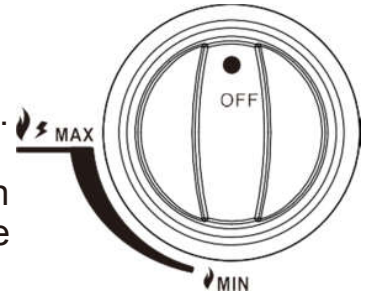

### Replacing the Battery

1. Unscrew the electrical ignition button and remove the old battery.
2. Replace with a new AA battery

Note: The negative (-) side of the battery goes in first. Please refer to the mark on the side of the cap.

### WARNING:

1. **Make sure the hood is completely open each time you attempt to light the grill. Failure to open the hood could lead to delayed ignition resulting in bodily harm.**
2. **This grill is equipped with a flame observation hole in the side panel. Wear protective mitts before using the flame observation hole.**

**CAUTION:** It is important to inspect the full length of the gas line hose. If it is evident there is excessive abrasion or wear, or the hose is cut, the hose must be replaced prior to the appliance being used.

If required, check your parts list for the proper replacement hose assembly. It will be necessary to open the bottom door to fully inspect the hose.

**CAUTION:** Regulator and hose must run outside the cart and then route through the hole on the left side panel of the cart before connecting with tank. See page 18 for detailed assembly instructions.

# OPERATING INSTRUCTIONS

## Checking the Flame

Refer to Fig.26 below (side view of grill) for where to check the flame after the grill is lit. Make sure you have a stable, mostly blue flame.

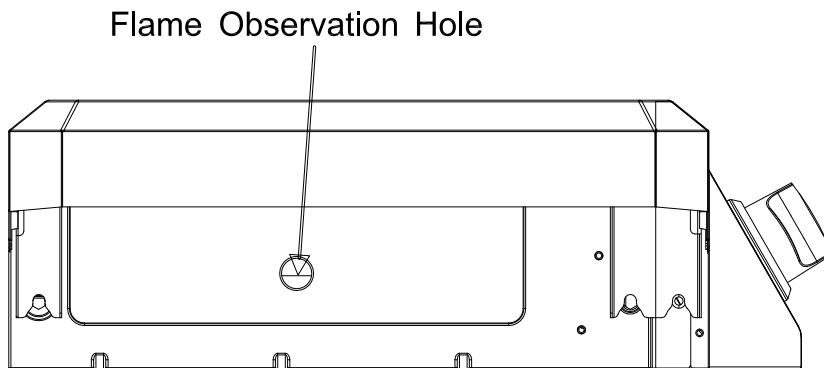

Fig.26

## Air Shutter Adjustment

The gas burner shutters are adjusted at the factory for your convenience. The settings are: (a) 1/4 in. open for LP gas.

If you desire to fine tune your shutter adjustment (or if your flame is more yellow rather than blue), please follow this procedure.

**WARNING: Do not touch burner after adjustments. The burner is hot.**

- The shutters are located on the end of the gas burners underneath the firebox. See Fig.27.
- Loosen the air shutter screw.
- Light the burner to be adjusted.
- With a protected, gloved hand, fine tune the air shutter until a stable, mostly blue flame is observed through the flame observation hole on each side of the firebox. Acceptable flames are shown in Fig.34.
- Tighten the air shutter locking screw enough to hold the shutter in place.
- Repeat procedure on other burners.

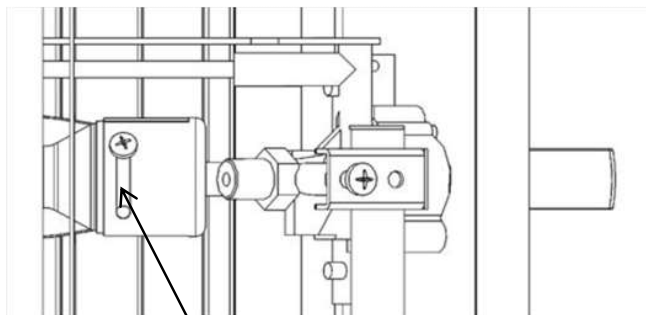

Fig.27 Air Shutter

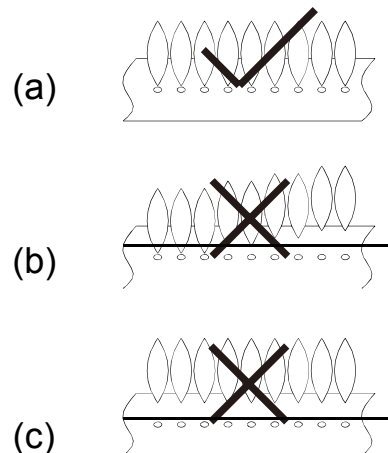

Fig. 28 Acceptable Flame only (a)



# OPERATING INSTRUCTIONS

---

## Match Lighting Instructions

**IMPORTANT: The hood must be open when match lighting any burner.**

1. Turn on gas supply
  - a. If portable, at the LP cylinder valve.
  - b. If permanent gas supply, at the manual gas shutoff valve.
2. Locate the flame observation holes on each side.
3. Access the match holder stick under right side table.
4. Attach either the match or paper to the clip (Fig.29), light the match and insert it close to the ports of the burner, and push and turn the depressed knob to the left to “MAX” position.

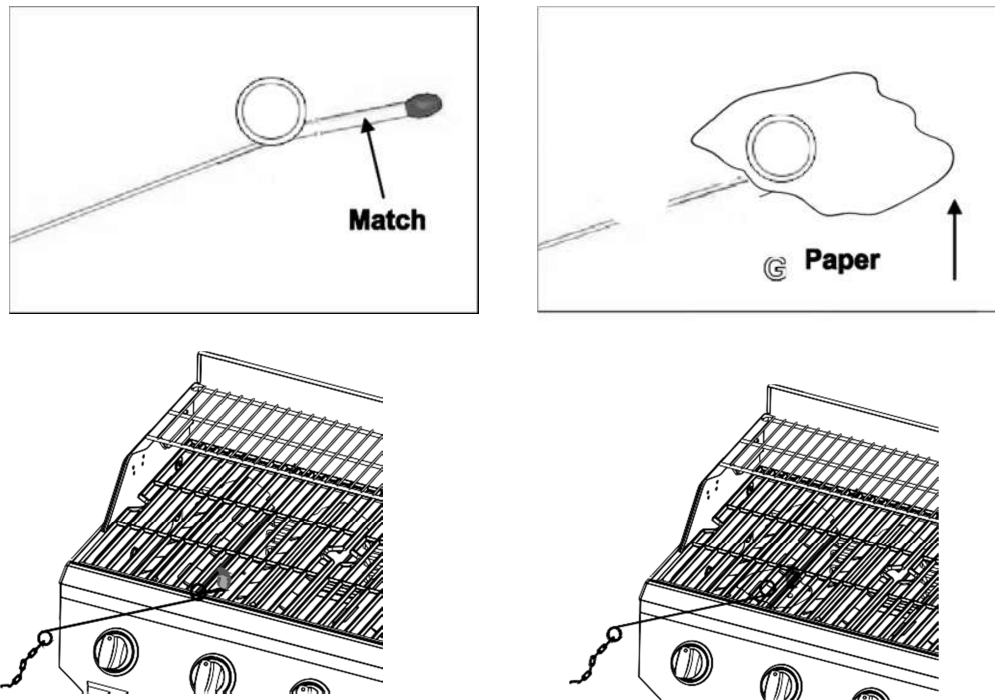

Fig. 29 Match/Paper Lighting Illustration

5. The center burner (if needed) can be lit from center grid by inserting the match clip into the front side of heat tent. Light this burner before igniting both outside burners.
6. Depress burner valve for that burner and turn to “MAX.”
7. Observe that the burner has ignited. Remove the match and extinguish.
8. Repeat steps 2-6 for the next burner.

## Breaking in Your Grill

When firing your grill for the first time, it is advisable to run the main burner(s) on “MAX” for 20 minutes with the hood down, and then turn the main burners off. This tempers the grill.

# OPERATING INSTRUCTIONS

---

## Preheating Grill

It is extremely important that your grill be up to temperature before you begin using it. After lighting, close the hood and preheat the grill on “MAX” for 15 minutes. This preheating will ensure that the cooking grate is hot enough for proper grilling.

**CAUTION: Do not cover the cooking grate during the preheating period.**

**WARNING: Never leave a grill unattended to guard against possible grease fires getting out of control. Grease fires can be severe and cause grill damage, property damage and bodily harm.**

## Open or Closed Hood for Grilling

Cooking with the lid open or closed is a matter of personal preference. Cooking with the lid closed is recommended if you enjoy cooking at maximum “searing” temperatures. This method will also produce more “flare up”, speed the cooking procedure and will give you a more robust, smoky, outdoor flavor. If you prefer cooking slower with less flare up, we suggest the lid-open method.

We recommend always cooking with the lid CLOSED if you are in a windy area or colder climate. Your grill has been designed and constructed to give you maximum flexibility and cooking performance. Be creative. Try different cooking methods on your grill and determine which suits your needs best. There is no right or wrong way to cook, just different cooking styles. Get creative and enjoy!

## Checking Gas Leaks

Before operating your grill, after refueling, check carefully to be certain that all connections are tight and there are no gas leaks.

- 1: Make 2-3 ounces of leak solution by mixing liquid dishwashing soap with water.
- 2: Make certain all control knobs are in the “OFF” position.
- 3: Brush small amounts of the leak solution on all the fittings and turn the gas on.
- 4: If bubbles appear, there is a leak. Proceed to step 5.
- 5: Turn the gas off and tighten all connections.
- 6: Go back to step 1 to retest the fittings.
- 7: If bubbles continue to appear, turn the gas off. Contact customer service.

**WARNING: Never use a match or open flame for leak detection. Use of an open flame could result in a fire, explosion and bodily harm.**

**IMPORTANT: When connecting or replacing any gas pipe or fittings, all joints must be sealed with approved leak-proof sealing compound or plumber’s tape.**

# CARE AND MAINTENANCE

---

**WARNING:** Please remember this is an outdoor gas grill. Many areas of the grill generate extreme heat. We have taken every precaution to protect you from the contact areas. However, it is impossible to isolate all high-temperature areas. Therefore, use good judgment and a certain degree of caution when grilling on this product. We suggest a covered, protected hand during operation of grill. Do not move your grill when it is in operation or hot to the touch. Wait until your unit is turned off and properly cooled down before moving it. Failure to follow this warning could result in personal injury.

## Post Heating

To keep the grates free of charred food remains, run the grill on “MAX” for 15 minutes after cooking is complete and food has been removed.

**CAUTION:** Do not cover the grill during the post heating period.

After post heating your grill, turn the control knobs to the “OFF” position.

## Propane Tank Shut-Off

After the firebox cool down, the propane tank valve should also be closed. If you do not want to wait for the firebox to cool, use a covered hand to turn off the propane tank valve.

**WARNING:** Do not attempt to turn off the LP tank valve without first covering your hand with a protective mitt or allowing the grill to cool down. Failure to follow this warning could result in a severe burn.

## LP Gas Safety Requirement

For LP gas grills, the LP gas supply tank to be used must be: Constructed and marked in accordance with the Specifications for LP Gas Tanks of the US. Department of Transportation (DOT) or the National Standard of Canada, CAN/CSA-B339 Cylinders, Spheres and Tubes for Transportation of Dangerous Goods; and Commission, as applicable; and Provided with a listed Overfill Prevention Device (OPD). The tank should be 12 inches in diameter and 18-1/2 inches tall and be equipped with a Type-I fitting.

The tank supply system must be arranged for vapor withdrawal.

The tank used must include a collar to protect the cylinder valve.

The tank should be provided with a cylinder connection device compatible with the connection for outdoor cooking appliances.

Do not operate the gas grill indoors or in any enclosed area. If the gas grill is not in use, the gas must be turned off at the supply tank. If the grill is to be stored indoors, disconnect the gas supply tank and store the tank in an upright position in a cool, well-ventilated outdoor location away from your grill or any other heat source.

When checking for gas leaks, do not use an open flame. Use a soapy water solution and apply it to the pipe joints and fittings with a brush and check for bubbles. Check flexible hoses for cuts and wear that may affect the safe operation of the grill. Only the factory supplied hose and regulator must be used. Use only replacement regulator and hose assembly specified by manufacturer.

## CARE AND MAINTENANCE

---

LP tank should be securely locked by the gas cylinder safety stop at all times. An unlocked tank may fall or tilt which can cause injury or property damage. It is recommended to lock the tank all the time.

Refer to Fig. 27 and Fig. 28. After positioning the tank in the opening, lift up the gas cylinder safety stop to lock the tank. Use only 20 lb. gas tank (see LP Gas Safety Requirements for Additional Information).

### **Handling the Liquid Propane Tank Safely**

Remember to handle your portable liquid propane tank carefully when you take it to your dealer for a refill. Avoid dropping it or bumping it against sharp objects. Liquid propane tanks are sturdily constructed, but a series of hard jolts could damage the container.

When transporting the tank to your local propane gas dealer, make sure the valve is closed tightly and the protective cover is in place. Position the tank securely in an upright position so it will not roll around your vehicle.

If you plan to make stops for shopping or errands, have your liquid propane tank filled at the last stop before going home. Again, make certain the refilled tank is secure and in an upright position. When you return home, remove the refilled tank from your vehicle. Never leave a portable liquid propane tank inside a vehicle that may become overheated by the sun.

Your local liquid propane gas dealer will gladly offer you additional safety tips.

### **Storing the Liquid Propane Tank Safely**

Whether you are between cross-country treks in your recreational vehicle or looking for a place to keep the liquid propane tank to provide fuel for your outdoor grill, keep in mind some basic safety rules about storing portable liquid propane tanks:

Do not store the tanks (whether full or empty) inside your home, the living area of an R.V., a garage, basement or workshop. It is unlikely that liquid propane will leak from the tanks. If it should leak, the fuel could be exposed to sparks from automobiles, power tools or other appliances. When storing or transporting your LP tank, it must remain in an upright position.

Never lay your LP tank down on its side whether it is full or empty. Never store a spare tank under or near your grill.

**CAUTION: Never transport or move your grill or grill tank without first closing the manual valve on your liquid propane gas tank.**

The best place to store a liquid propane tank is in a shady or protected spot outdoors, behind your home or garage, or on a screened porch but where it is out of reach of children. Liquid propane will not evaporate. It is in a strong, closed container. It will not lose any of its clean-burning heat content, even if left outside year-round.

## **CARE AND MAINTENANCE**

---

**WARNING:** When not connected to your grill, the LP gas tank must be stored in an upright position in a cool, shady, well-ventilated, outdoor location away from your grill or any other heat source. Failure to follow this warning could lead to tank valve damage, fire hazard and personal injury.

### **Refilling a Propane Tank**

It is extremely important that your LP tank be filled properly when you take it to be refilled. Be sure to use a reputable LP dealer and observe how the tank is filled and at what capacity. An overfilled LP tank can be dangerous.

The proper way to fill a tank is by weight. The empty tank should be placed on a scale. The scale weights should be readjusted to a weight that would allow up to 80% of the total weight. The filling operation must end once the tank is filled to 80% of its total capacity. If the tank is not completely empty, the scale readjustment must be changed to consider the propane (LP) already in the tank.

**WARNING: An LP (propane) tank is overfilled if it contains more than 80% of its total capacity of propane (LP).**

An incorrectly filled or an overfilled LP (propane) tank can be dangerous. If a tank is overfilled and the weather causes the warming of the LP tank, (a hot day, tank left in sun or stored indoors) internal pressure is created due to expansion of the propane which in turn may cause the LP gas to be released through the pressure relief valve on the tank. The pressure relief valve is a safety device required on 20 lb. propane tanks by the Department of Transportation or the National Standard of Canada, CAN/CSA-B339 Cylinders, Spheres and Tubes for Transportation of Dangerous Goods; and Commission, as applicable, to prevent a catastrophic tank failure due to excessive pressure. LP gas released from the tank is flammable and can be explosive.

**IMPORTANT: When connecting or replacing gas pipe or fittings, all joints must be sealed with approved leak-proof sealing compound or plumber's tape. After making connections, check all joints for leaks using a soapy water solution and a brush.**

**WARNING: Never use an open flame to test for gas leaks. Use of an open flame could result in a fire, explosion and bodily harm.**

### **Stainless Steel**

The control panel and door of the gas grill is made of stainless steel. Stainless steel is non-rusting in certain conditions; therefore, a cover and stainless steel cleaner should be used when the grill is not in use.

Clean with stainless steel cleaner on all non-cooking surfaces once a month. Never clean the stainless steel when it is hot.

After initial grilling, certain areas of the grill (i.e the vents, hood and firebox) may discolor. This is a normal discoloration caused by the intense heat from the burners.

## CARE AND MAINTENANCE

---

Specks of grease can gather on the surface of the stainless steel and get baked-on. These can usually be removed with warm soapy water or a stainless steel cleaner. As a last resort a mild abrasive pad could be used with a stainless cleaner. Use light pressure on the pad and always scrub in the direction of the grain. There are many outstanding products that will help clean and protect on all non-cooking surfaces.

Do not use steel wool to clean the grill.

Do not use abrasive cleaners on the polished surface. Use caution when cleaning. Metal polish or mild chrome cleaner can be used to bring back luster and highlights. Naval jelly can be used to remove rust stains that occur from outside sources. Follow the naval jelly instructions carefully.

To touch up minor scratches in the stainless steel, sand the affected surface lightly with 160 dry grit emery sand paper in the direction of the grain.

### Burners

Burners are made of stainless steel and can be soaked in water and cleaned with a brass wire brush or a still bristle brush. Check every port hole for clogs. Use a wire pin (smaller than the port) to clean clogged ports. Do not enlarge any ports. Make sure the burners are dry before installing them back to the grill. See Fig.30



Fig.30

Spiders and insects can nest inside the burners of this or any other grill and cause the gas to flow from the front of the burner. This could cause a fire to occur behind the valve panel, thereby damaging the grill and making it unsafe to operate. Inspect the burners at least once a year or immediately after any of the following conditions occur:

1. The smell of gas in conjunction with the burner flames appearing yellow.
2. The grill does not reach temperature.
3. The grill heats unevenly.
4. The burners make popping noises.

### Drip Tray

The drip tray collects excessive grease runoff and fallen food particles.

Allow the tray and its contents to cool before cleaning. Slide the tray out and wipe it clean.

Make sure the tray is installed before using the grill.

It is highly recommended that you check the tray regularly to avoid any possibility of a grease fire; however, most of the drippings will vaporize back into the cooked item giving you an outdoor grilled flavor.

# CARE AND MAINTENANCE

---

## Helpful Care and Maintenance Hints

Before grilling, pre-heat grill for 15 minutes on “MAX” with hood down. To avoid uncontrolled flare-ups or grease fires, grill meats with hood open. Close hood if meats are thick or weather is cold, or if you are using a rotisserie or indirect cooking.

Always protect your hand with a pot mitten or cooking glove when coming into contact with a hot surface.

Hood up when grilling meats, especially chicken. Hood down when indirect or rotisserie cooking.

NEVER leave your grill unattended while cooking.

After use, close hood, turn burners to “MAX” for 15 min. for self-cleaning, grease burn off.

Care and Maintenance Time Table Chart

Grill Item	Frequency Based on Normal Use	Cleaning Method
Painted surface	Twice yearly	Car wax
Stainless surface	Twice yearly	Stainless cleaner
All grates	After each use	Burn off and wipe
Porcelain	15 days	Scrub pad soapy water/ Dishwasher safe
Burner heat tents	30 days	Wire brush
Burners	90 days	Wire brush
Burner box interior	120 days	Interior grill cleaning products

## Gauging amount of LPG fuel

To gauge the amount of propane fuel in your gas tank, the grill must be in operation. Place your hand at the top of the tank and slowly move down the side until the tank feels cool to the touch. This will indicate the approximate amount of propane gas in your tank; if 3/4 empty, refill.

**Do not use charcoal briquettes or any flammable material with your grill. Use of such material will void your warranty and may lead to a fire, explosion and bodily harm.**

# TROUBLESHOOTING

Many solutions given here can make your grilling experience safer and more enjoyable. You can also call customer service department at 1-800-963-0211, 8 a.m. - 6 p.m., EST, Monday-Thursday, 8 a.m.- 5 p.m., EST, Friday.

Problem	Possible Cause	Corrective Action
Grill or side cooker will not light.	<ol style="list-style-type: none"> <li>1. The ignition wire came off the electrical igniter/valve.</li> <li>2. The distance between the ignition pin and the burner is greater than 5/32 in. - 3/16 in. (side burner).</li> <li>3. The ignition wire is broken.</li> <li>4. The battery has died.</li> <li>5. The battery is in the wrong polarity.</li> <li>6. The electrode tip does not produce sparks at the burner port.</li> <li>7. No gas supplied.</li> <li>8. Air shutter opening is too big.</li> </ol>	<ol style="list-style-type: none"> <li>1. Reconnect the ignition wire to the electrical igniter/valve.</li> <li>2. Loosen the ignition pin and adjust the distance, then fasten it again.</li> <li>3. Call customer service for a replacement ignition wire.</li> <li>4. Install a new AA battery.</li> <li>5. Change the battery polarity.</li> <li>6. Reinstall the electrode.</li> <li>7. Turn on the regulator valve.</li> <li>8. Loosen the air shutter and adjust the opening to a smaller size.</li> </ol>
Burner flame is yellow and gas odor can be smelled.	<ol style="list-style-type: none"> <li>1. The air shutter opening is not properly set.</li> <li>2. Spiders or insects block the air shutter.</li> </ol>	<ol style="list-style-type: none"> <li>1. Loosen the air shutter and adjust the opening to have blue flames. 1/4 in. opening for LPG. 1/8 in. or less opening for NG.</li> <li>2. Clean blockages.</li> <li>3. Check for the source of gas leaks.</li> </ol>
Excessive flare-up.	<ol style="list-style-type: none"> <li>1. Grilling fatty meats.</li> <li>2. Knobs on "MAX."</li> <li>3. Spray water on gas flames.</li> <li>4. Hood closed when grilling.</li> </ol>	<ol style="list-style-type: none"> <li>1. Hood up when grilling.</li> <li>2. Grill fatty meats when the grates are cold while the knobs are on the "MIN" setting. Move the meats to the warming rack if flare up continues until flame settles down. Never spray water on gas flames.</li> </ol>



# TROUBLESHOOTING

Problem	Possible Cause	Corrective Action						
Excessive flare-up.	<ol style="list-style-type: none"> <li>1. LP tank is empty.</li> <li>2. Burner is not aligned with the control valve.</li> <li>3. Gas supply is not sufficient.</li> </ol>	<ol style="list-style-type: none"> <li>1. Refill the LP Tank.</li> <li>2. Install the burner correctly.</li> <li>3. Check the gas supply hose and make sure there are no leaks and no knots.</li> </ol>						
Low heat with the knob in "MAX" position.	<ol style="list-style-type: none"> <li>1. Ports are blocked.</li> <li>2. LP tank has run out.</li> </ol>	<table border="1" data-bbox="1027 674 1347 868"> <tr> <td data-bbox="1027 674 1187 717">Burner</td> <td data-bbox="1187 674 1347 717">Burner</td> </tr> <tr> <td data-bbox="1027 717 1187 793">Main Burner</td> <td data-bbox="1187 717 1347 793">ø 1.04mm</td> </tr> <tr> <td data-bbox="1027 793 1187 868">Side Burner</td> <td data-bbox="1187 793 1347 868">ø 1.04mm</td> </tr> </table> <ol style="list-style-type: none"> <li>1. Clear ports of any obstructions.</li> <li>2. Refill the LP tank.</li> </ol>	Burner	Burner	Main Burner	ø 1.04mm	Side Burner	ø 1.04mm
Burner	Burner							
Main Burner	ø 1.04mm							
Side Burner	ø 1.04mm							
Low heat, LP gas.	<p>The propane regulator assembly incorporates an excess flow device designed to supply the grill with sufficient gas flow.</p> <p>Rapid changes in pressure can trigger the excess flow device, providing a low flame and low temperature.</p>	<p>Please follow these instructions:</p> <ol style="list-style-type: none"> <li>1. Make sure all burners are "OFF".</li> <li>2. Open the tank valve and wait 5 minutes.</li> <li>3. Light the burner one at a time following the lighting instructions listed on the door liner and Page 24.</li> </ol>						

# **WARRANTY**

---

**Proof of purchase** is required to access this warranty program, which is in effect from the date of purchase. Customers will be subject to parts, shipping, and handling fees if unable to provide proof of the purchase or after the warranty has expired.

If you have any questions or problems, you can call our customer service department at 1-800-963-0211, 8 a.m. - 6 p.m., EST, Monday-Thursday, 8 a.m. - 5 p.m., EST, Friday.

## **Limited Warranty**

**5-Year Warranty** on stainless steelburners

**1-Year Warranty** on all parts affecting the operation of the gas grill due to damage

## **Warranty Provisions:**

This warranty is non-transferable and does not cover failures due to misuse or improper installation or maintenance.

This warranty is for replacement of defective parts only. We are not responsible for incidental or consequential damages or labor costs.

This warranty does not cover corrosion or discoloration after the grill is used, or lack of maintenance, hostile environment, accidents, alterations, abuse or neglect.

**This warranty does not cover damage caused by heat, abrasive and chemical cleaners, or any damage to other components used in the installation or operation of the gas grill.**

**Some states do not allow the limitation or exclusion of incidental or consequential damages, so the above limitations or exclusions may not apply to you. This warranty gives you specific legal rights, and you may also have other rights that vary from state to state.**

Manufacturer's: Zhongshan Vanward Electric Appliance CO., LTD.  
Master Contract: 230994



