

# HEPA Air Cleaners

## Installation Manual

400 Series HEPA Air Cleaners  
400D (GFI #4640)  
& 400R (GFI #4641)

Please Read And Save These Instructions

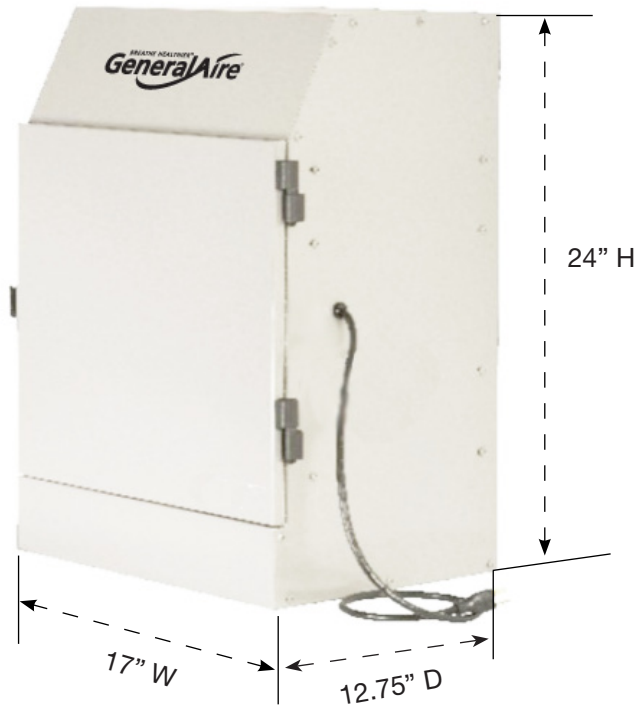

### GENERALAIRE® HEPA AIR CLEANERS

Model	400D (Duct Mount)	400R (Room/Portable)
<b>GFI #</b>	<b>4640</b>	<b>4641</b>
Weight (Pounds)	35	
Dimensions (Inches)	24 H x 12.75 D x 17 W	
Rated Air Flow (CFM)	400	
Min. Ave. % Eff. 1.0-3.0 Microns	HEPA 99.97%	
Operation	Air Flow From Furnace Through Air Cleaner/Fan Coil	Room / Portable
Replacement Filters	1. HEPA ( <b>GFI #4645</b> ) - Replace Every 2 Years / 2. Pre-Filter ( <b>GFI #4646</b> ) With Carbon - Replace Every Year	
Power Consumption (Watts)	300	
Amperage	115V / 1 / 60Hz; 2.75 Amp	
Certification	cCSA <sub>US</sub>	
Collar / Intake / Exhaust Openings (Inches)	Collar: 8 (203mm) Intake: 3.75 (95mm) x 14.375 (365mm) Exhaust: 3.75 (95mm) x 14.375 (365mm)	
Pallet Quantity	18	
Mounting	Return Air Duct Mount / Collar	Room / Portable
Warranty (Years)	5	
In the Box	HEPA Air Cleaner, 9' Power Cord, Installation Manual, Duct Collars, Pre-Filter, HEPA Filter, 3 Mounting Brackets, Screws, Mounting Template	HEPA Air Cleaner, 9' Power Cord, Installation Manual, Pre-Filter, HEPA Filter, Screws, Caster Wheels



General Filters, Inc.  
43800 Grand River Avenue  
Novi, Michigan 48375  
Toll Free: (866) 476-5101  
www.generalaire.com



# INSTALLATION

**⚠ WARNING:** Disconnect electrical power before beginning installation.



- Before Installing Your New Surface or Duct Mount HEPA Air Cleaner, Determine:
  - Location on the return side of the duct for installation of your HEPA 200D or 400D.
  - Determine if you will be installing via surface mount or duct mount.

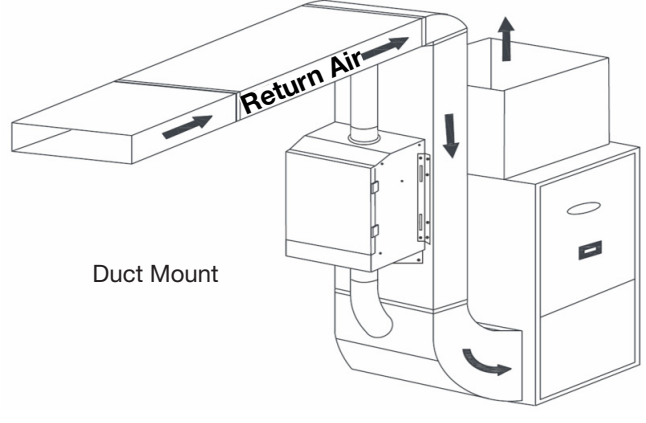
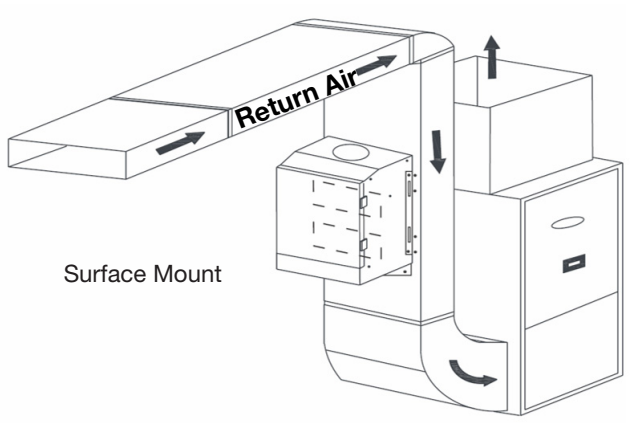

## Surface Mount HEPA (Model 400D)

- Install mounting support bracket on return air duct for bottom support using the provided #8 x 1/2" screws.
- Install the side mounting brackets on both sides of the unit by removing and remounting the screws located on the unit\*
- Using the provided template, cut rectangular intake and exhaust holes in the duct work. Each will measure 3.75" high by 14.375" wide.
- Cut out the intake and exhaust holes from the back of the HEPA unit.
- Hang the HEPA Air Cleaner onto the duct, first resting on the bottom support bracket. Screw side brackets into the duct using the provided #8 x 1/2" screws.\*
- Remove filters from plastic bags. Insert the pre-filter with carbon in the top slot; the HEPA filter in the bottom slot.
- Plug unit into a 120V outlet. Turn fan on using the dial control to the preferred speed.

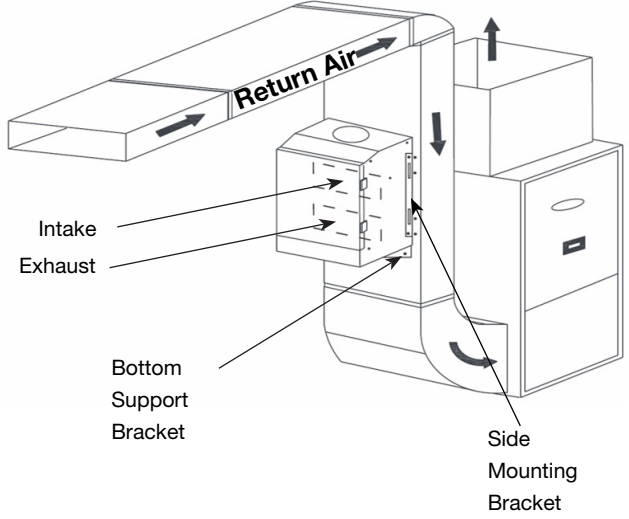

Duct Mount Collars Are Included!  
**\*Side Mounting Brackets Add 1" on Either Side of HEPA Unit; Requiring a Minimum Duct Width of 20" for Installation**

## INSTALLATION CONT.

### Duct Mount HEPA (Model 400D)

1. Install mounting support bracket on return air duct for bottom support using the provided #8 x 1/2" screws.
2. Install the side mounting brackets on both sides of the unit by removing and remounting the screws located on the unit.\*
3. Cut round intake and exhaust holes in the duct work; each 8" in diameter.
4. Cut out the round intake and exhaust holes on the top and bottom of the HEPA unit.
5. Hang the HEPA Air Cleaner onto the duct using the provided #8 x 1/2" screws. Attach duct to intake and exhaust holes. Screw side brackets into the duct using the provided #8 x 1/2" screws.\*
6. Install 8" collars using the provided #8 x 1/2" screws (12 included).
7. Remove filters from plastic bags. Insert the pre-filter with carbon in the top slot; the HEPA filter in the bottom slot.
8. Plug unit into a 120V outlet. Turn fan on using the dial control to the preferred speed.

See maintenance on the back page.

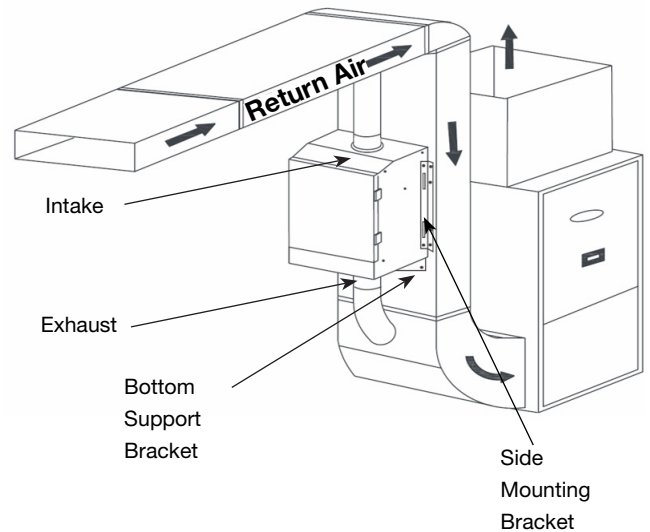

Duct Mount Collars Are Included!

**\*Side Mounting Brackets Add 1" on Either Side of HEPA Unit; Requiring a Minimum Duct Width of 20" for Installation**

### Room / Portable Unit (Model 400P)

1. Remove filters from plastic bags. Insert the prefilter with carbon in the top slot and the HEPA filter in the bottom slot.
2. Install caster wheels.
3. Place in room of choice and pug the unit into a 120V outlet.
4. Turn variable speed dial control to increase airflow (CFM).

See maintenance on the back page.

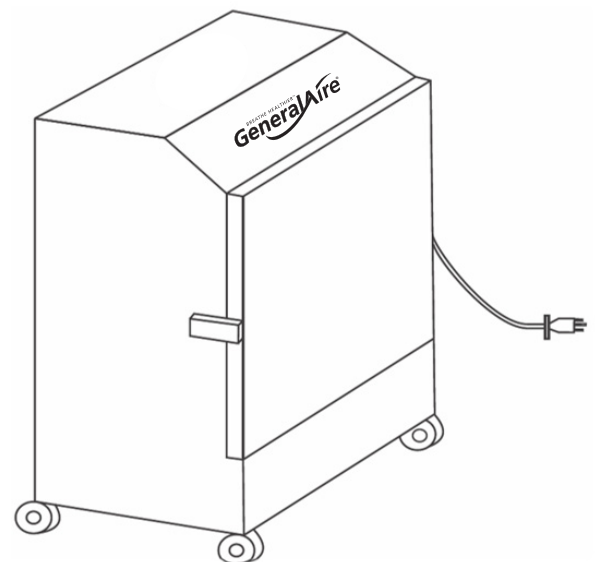

## MAINTENANCE

**⚠ IMPORTANT:** To ensure your safety and the longevity of your unit, we recommend:

- Contacting a licensed contractor to perform maintenance or repairs.

**⚠ WARNING:** Disconnect electrical power before beginning maintenance.



1. Replace your pre-filter with carbon (GFI #4646) every 3 to 6 months.
2. Replace your HEPA filter (GFI #4645) every 2 years.



1. Pleated Pre-Filter With Carbon (GFI #4646)
2. HEPA Filter (GFI #4645)
3. Child Safety Switch
4. PSC Motor
5. Variable Motor Control (Not Shown)
6. Door Latch
7. Casters (R Model; Not Shown)

## WARRANTY

Your new HEPA Air Cleaner carries a 5-year limited warranty. For our complete warranty policy visit [www.generalfilters.com](http://www.generalfilters.com).