

This Owner's Manual is provided and hosted by [Appliance Factory Parts](#).



# MAGIC CHEF MCC1311ARB Owner's Manual

[Shop genuine replacement parts for MAGIC CHEF  
MCC1311ARB](#)



[Find Your MAGIC CHEF Microwave Parts - Select From 180 Models](#)

----- Manual continues below -----



**Magic Chef®**

**1.3 Cu. Ft.**

**Built - in Convection Microwave Oven**

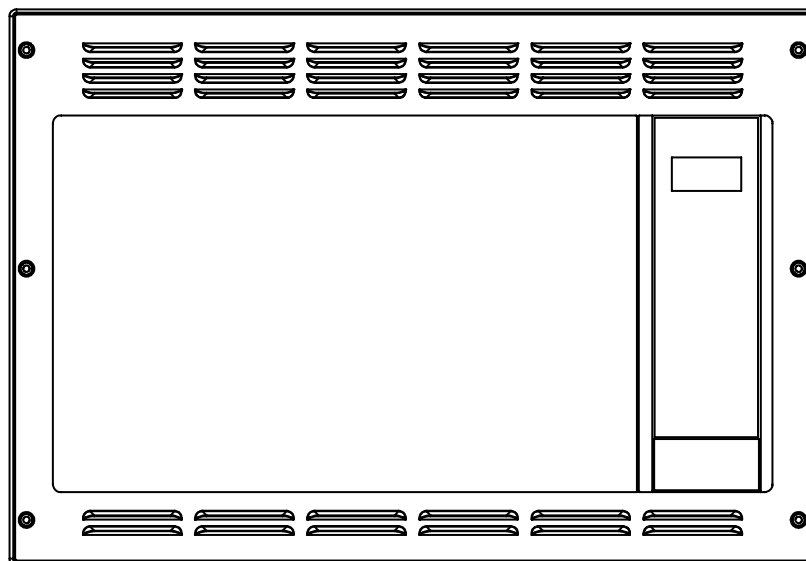

Model MCC1311ARB/MCC1311ARS

**PLEASE READ THIS MANUAL CAREFULLY BEFORE USING YOUR  
MICROWAVE OVEN AND KEEP IT FOR FUTURE REFERENCE.**



## Product Registration

Thank you for purchasing a Magic Chef product. The first step to protect your new product is to complete the product registration on our website: [www.mcappliance.com/register](http://www.mcappliance.com/register). The benefits of registering your product include the following:

1. Registering your product will allow us to contact you regarding a safety notification or product update.
2. Registering your product will allow for more efficient warranty service processing when warranty service is required.
3. Registering your product could act as your proof of purchase in the event of insurance loss.

Once again, thank you for purchasing a Magic Chef product.

# TABLE OF CONTENTS

• MICROWAVE OVEN SAFETY.....	1
UTILISATION SÉCURITAIRE DU MICROONDES .....	1
• IMPORTANT SAFETY INSTRUCTIONS.....	1
INSTRUCTIONS IMPORTANTES DE SÉCURITÉ .....	1
• PRECAUTIONS TO AVOID POSSIBLE EXPOSURE TO EXCESSIVE MICROWAVE ENERGY.....	2
PRÉCAUTIONS POUR ÉVITER UNE EXPOSITION À UNE QUANTITÉ EXCESSIVE D'ÉNERGIE DU MICROONDES.....	2
• INSTALLATION INSTRUCTIONS.....	3
INSTRUCTIONS D'INSTALLATION.....	3
• GROUNDING INSTRUCTIONS .....	3
INSTRUCTIONS DE MISE À LA TERRE.....	3
• SPECIFICATIONS.....	4
• PARTS AND FEATURES.....	5
TURNTABLE.....	5
• MICROWAVE OVEN CONTROL.....	5
DISPLAY.....	5
SETTING THE CLOCK.....	6
TIMER.....	6
MICROWAVE COOKING.....	6
GRILL.....	6
CONVECTION.....	7
MICROWAVE + GRILL.....	7
MICROWAVE + CONVECTION.....	7
WEIGHT DEFROST.....	7
MULTI-STAGE COOKING.....	7
POPCORN.....	8
POTATO.....	8
BEVERAGE.....	8
PIZZA.....	8
SPAGHETTI.....	8
CHICKEN.....	8
CAKE.....	8
REHEAT.....	8
LOCK FUNCTION FOR CHILDREN.....	9
TO STOP THE OVEN WHILE THE OVEN IS OPERATING.....	9
OVERHEATING PROTECTION.....	9
MICROTHERM PROTECTION.....	9
SENSOR MALFUNCTION PROTECTION.....	9
COOLING FEATURE.....	9
• CARE YOUR MICROWAVE OVEN.....	10
• BEFORE YOU CALL FOR SERVICE.....	11
• CARE AND CLEANING.....	11
• QUESTIONS AND ANSWERS.....	12
• USE YOU MICROWAVE OVEN SAFELY.....	13
• ARCING.....	13
• LIMITED WARRANTY.....	14

# MICROWAVE OVEN SAFETY

## Your safety and the safety of others are very important.

We have provided many important safety messages in this manual and on your appliance. Always read and obey all safety messages.



This is the safety alert symbol.

This symbol alerts you to potential hazards that can kill or hurt you and others.

All safety messages will follow the safety alert symbol and either the word “DANGER” or “WARNING.”

These words mean:

**⚠ DANGER**

**You can be killed or seriously injured if you don't immediately follow instructions.**

**⚠ WARNING**

**You can be killed or seriously injured if you don't follow instructions.**

All safety messages will tell you what the potential hazard is, tell you how to reduce the chance of injury, and tell you what can happen if the instructions are not followed.

## IMPORTANT SAFETY INSTRUCTIONS

When using electrical appliances basic safety precautions should be followed, including the following:

**WARNING:** To reduce the risk of burns, electric shock, fire, injury to persons, or exposure to excessive microwave energy:

- Read all instructions before using the microwave oven.
- Read and follow the specific “PRECAUTIONS TO AVOID POSSIBLE EXPOSURE TO EXCESSIVE MICROWAVE ENERGY” found in this section.
- The microwave oven must be grounded. Connect only to properly grounded outlet. See “GROUNDING INSTRUCTIONS” found in this section and in the provided Installation Instructions.
- Install or locate the microwave oven only in accordance with the provided Installation Instructions.
- Some products such as whole eggs in the shell and sealed containers – for example, closed glass jars – are able to explode and should not be heated in the microwave oven.
- Use the microwave oven only for its intended use as described in this manual. Do not use corrosive chemicals or vapors in the microwave oven. This type of oven is specifically designed to heat, cook, or dry food. It is not designed for industrial or laboratory use.
- As with any appliance, close supervision is necessary when used by children.
- Do not operate the microwave oven if it has a damaged cord or plug, if it is not working properly, or if it has been damaged or dropped.
- The microwave oven should be serviced only by qualified service personnel. Call an authorized service company for examination, repair, or adjustment.
- See door surface cleaning instructions in the “Microwave Oven Care” section.
- To reduce the risk of fire in the oven cavity:
  - Do not overcook food. Carefully attend the microwave oven when paper, plastic, or other combustible materials are placed inside the oven to facilitate cooking.
  - Remove wire twist-ties from paper or plastic bags before placing bags in oven.
  - If materials inside the oven ignite, keep oven door closed, turn oven off, and disconnect the power cord, or shut off power at the fuse or circuit breaker panel.
  - Do not use the cavity for storage purposes. Do not leave paper products, cooking utensils, or food in the cavity when not in use.
- Liquids, such as water, coffee, or tea are able to be overheated beyond the boiling point without appearing to be boiling. Visible bubbling or boiling when the container is removed from the microwave oven is not always present. **THIS COULD RESULT IN VERY HOT LIQUIDS SUDDENLY BOILING OVER WHEN THE CONTAINER IS DISTURBED OR A SPOON OR OTHER UTENSIL IS INSERTED INTO THE LIQUID.**

To reduce the risk of injury to persons:

  - Do not overheat the liquid.
  - Stir the liquid both before and halfway through heating it.
  - Do not use straight-sided containers with narrow necks.
  - After heating, allow the container to stand in the microwave oven for a short time before removing the container.
  - Use extreme care when inserting a spoon or other utensil into the container.
- Oversized foods or oversized metal utensils should not be inserted in the microwave oven as they may create a fire or risk of electric shock.
- Do not clean with metal scouring pads. Pieces can burn off the pad and touch electrical parts involving a risk of electric shock.

## SAVE THESE INSTRUCTIONS

# UTILISATION SÉCURITAIRE DU MICROONDES

## Votre sécurité et la sécurité des autres est importante.

Il y a plusieurs messages importants de sécurité dans ce manuel et sur votre appareil. Lisez et suivez toujours les messages de sécurité.



Ceci est le symbole d'avertissement.

Le symbole vous avertit des dangers potentiels qui peuvent tuer et blesser les autres et vous.

Tous les messages de sécurité suivront le symbole d'avertissement ou les mots «DANGER» ou «WARNING» (Avertissement).

Ces mots signifient :

### **DANGER**

Vous pouvez être tué ou gravement blessé si vous ne suivez pas **immédiatement** les instructions.

### **AVERTISSEMENT**

Vous pouvez être tué ou gravement blessé si vous ne suivez pas les instructions.

Tous les messages d'avertissement vous avertissent du danger potentiel, vous disent comment réduire les chances de blessures et vous avertissent de ce qui peut se produire si vous ne suivez pas les instructions.

## INSTRUCTIONS IMPORTANTES DE SÉCURITÉ

Lorsque vous utilisez des appareils électriques, vous devriez suivre des mesures de sécurité de base, incluant les suivantes :

**AVERTISSEMENT** : Pour réduire les risques de brûlures, de décharges électriques, de feu, de blessures ou d'exposition à des doses excessives d'énergie du microondes :

- Lisez toutes les instructions avant d'utiliser ce microondes.
- Lisez et suivez les «PRÉCAUTIONS POUR ÉVITER UNE POSSIBLE EXPOSITION À UNE QUANTITÉ EXCESSIVE D'ÉNERGIE DU MICROONDES» spécifiques rencontrées dans cette section.
- Le microondes doit avoir une mise à la terre. Branchez-le uniquement dans une prise avec une mise à la terre. Voir les «INSTRUCTIONS DE MISE À LA TERRE» dans cette section et dans les instructions d'installation.
- Installez ou placez le microondes selon les instructions d'installation.
- Certains produits comme des oeufs dans leur coquille et des contenants scellés – par exemple, des contenants de verres scellés – peuvent exploser et ne devraient pas être chauffés dans le microondes.
- Utilisez le microondes uniquement pour l'utilisation prévue et décrite dans ce manuel. Ne pas utiliser de produits chimiques corrosifs ou de vapeurs dans le microondes. Ce type de four est spécifiquement conçu pour réchauffer, cuire et sécher des aliments. Il n'est pas conçu pour une utilisation industrielle ou en laboratoire.
- Comme avec tous les appareils, une supervision est nécessaire lorsqu'ils sont utilisés par des enfants.
- Ne pas utiliser le microonde si le fil d'alimentation ou la fiche est endommagée, ne fonctionne pas normalement ou s'il a été endommagé ou a été échappé.
- Le microondes devrait être entretenu uniquement par du personnel qualifié. Appelez une compagnie d'entretien autorisée pour une évaluation, une réparation ou un ajustement.
- Lisez les instructions de nettoyage de la porte dans la section «Entretien du microondes».

■ Pour **réduire** le risque de feu dans le microondes :

- Ne pas surcuire la nourriture. Supervisez attentivement le microondes lorsque du papier, du plastique ou d'autres matériaux combustibles sont placés dans le microondes pour faciliter la cuisson.
- Enlevez les agrafes de fil des sacs de papier ou de plastique avant de placer les sacs dans le microondes.
- Si le matériel dans le microondes s'enflamme, gardez la porte fermée, éteignez le microondes et débranchez le fil d'alimentation ou débranchez le fusible ou le disjoncteur.
- Ne pas utiliser l'intérieur du microondes pour entreposer du matériel. Ne pas laisser de papier, d'ustensiles de cuisson ou de nourriture dans le microondes lorsqu'il n'est pas utilisé.
- Les liquides, comme l'eau, le café ou le thé peuvent être surchauffés au-dessus du point d'ébullition sans bouillir. Lorsque le contenant est retiré du microondes, un bouillonnement n'est pas toujours visible. **CECI PEUT AMENER DES LIQUIDES TRÈS CHAUD À BOUILLIR SOUDAINEMENT LORSQUE LE CONTENANT EST DÉPLACÉ OU QU'UNE CUILLÈRE OU UN AUTRE USTENSILE EST PLONGÉ DANS LE LIQUIDE.** Pour réduire le risque de blessures :
  - Ne pas surchauffer le liquide.
  - Brassez le liquide avant et pendant qu'il est réchauffé.
  - Ne pas utiliser de contenants droits avec des goulots.
  - Après l'avoir réchauffé, laissez le contenant dans le microondes pendant une courte période de temps avant de le déplacer.
  - Faites très attention lorsque vous insérez une cuillère ou un autre ustensile dans le contenant.
- Les aliments surdimensionnés ou les ustensiles de métal surdimensionnés ne devraient pas être placés dans le microondes puisqu'ils peuvent créer un risque de feu ou de décharges électriques.
- Ne pas **nettoyer** avec des tampons à récurer en métal. Des morceaux peuvent se détacher du tampon et toucher une pièce électrique créant un risque de décharges électriques.

**CONSERVEZ CES INSTRUCTIONS.**

## IMPORTANT SAFETY INSTRUCTIONS

- Do not operate any heating or cooking appliance beneath the microwave oven.
- Do not mount microwave oven over or near any portion of a heating or cooking appliance.
- Do not use paper products when appliance is operated in convection, combination, grill or "PAN BROWN" mode (on models with such features).
- Do not store any materials, other than manufacturer's recommended accessories, in this microwave oven when not in use.
- Do not store anything directly on top of the microwave oven when the microwave oven is in operation.
- Do not cover or block any openings on the microwave oven.
- Do not store this microwave oven outdoors. Do not use the microwave oven near water - for example, near a kitchen sink, in a wet basement, or near a swimming pool, or similar locations.
- Do not immerse cord or plug in water.
- Keep cord away from heated surfaces.
- Do not let cord hang over edge of table or counter.
- Do not mount over a sink.
- Do not cover racks or any other part of the microwave oven with metal foil. This will cause overheating of the microwave oven.

## SAVE THESE INSTRUCTIONS

## PRECAUTIONS TO AVOID POSSIBLE EXPOSURE TO EXCESSIVE MICROWAVE ENERGY

- (a) Do not attempt to operate this oven with the door open since open-door operation can result in harmful exposure to microwave energy. It is important not to defeat or tamper with the safety interlocks.
- (b) Do not place any object between the oven front face and the door or allow soil or cleaner residue to accumulate on sealing surfaces.
- (c) Do not operate the oven if it is damaged. It is particularly important that the oven door close properly and that there is no damage to the:
  - (1) Door (bent),
  - (2) Hinges and latches (broken or loosened),
  - (3) Door seals and sealing surfaces.
- (d) The oven should not be adjusted or repaired by anyone except properly qualified service personnel.

This device complies with Part 18 of the FCC Rules.

## INSTRUCTIONS IMPORTANTES DE SÉCURITÉ

- Ne pas utiliser d'appareils de cuisson ou de réchauffage sous le microondes.
- Ne pas placer le microondes sur ou près d'une partie d'un appareil de cuisson ou de réchauffage.
- Ne pas utiliser de papier lorsque l'appareil est utilisé en mode convection, combinaison, grill ou «PAN BROWN» (sur les modèles avec ces options).
- Ne pas entreposer de matériel, autre que ceux recommandés par le fabricant dans le microondes lorsqu'il n'est pas utilisé.
- Ne rien laisser sur le microondes lorsque le microondes est utilisé.
- Ne pas couvrir ou bloquer les ouvertures du microondes.
- Ne pas entreposer ce microondes, même à l'extérieur. Ne pas utiliser ce microondes près de l'eau – par exemple, un évier de cuisine, un sous-sol humide ou près d'une piscine ou d'un endroit similaire.
- Ne pas tremper le fil d'alimentation ou le brancher dans de l'eau.
- Gardez le fil d'alimentation loin des surfaces chauffées.
- Ne pas laisser le fil d'alimentation pendant sur le côté de la table ou du comptoir.
- Ne pas placer au-dessus de l'évier.
- Ne pas couvrir les étagères ou une autre pièce du microondes avec du papier d'aluminium. Ce qui surchauffera le microondes.

**CONSERVEZ CES INSTRUCTIONS.**

## PRÉCAUTIONS POUR ÉVITER UNE EXPOSITION À UNE QUANTITÉ EXCESSIVE D'ÉNERGIE DU MICROONDES

- (a) Ne pas essayer d'utiliser le microondes lorsque la porte est ouverte puis éviter une exposition nocive aux énergies du microondes. Il est important de ne pas trafiquer ou de modifier le mécanisme de sécurité.
- (b) Ne pas placer d'objets entre la face avant du microondes et la porte ou de permettre à de la terre ou des résidus de nettoyage de s'accumuler sur les scellants.
- (c) Ne pas utiliser le microondes s'il est endommagé. Il est particulièrement important que la porte du microondes soit bien fermée et qu'il n'y ait pas de dommages à :
  - (1) la porte (courbé),
  - (2) les gonds et les loquets (brisé ou mal serré),
  - (3) Les scellants de la porte et des surfaces.
- (d) Le microondes devrait être ajusté ou réparé par du personnel qualifié.

L'appareil est conforme à la partie 18 des règles du FCC.

# INSTALLATION INSTRUCTIONS

## Unpacking

1. Empty the microwave oven of any packing materials.
2. Clean the inside with a soft, damp cloth.
3. Check for damage, such as:
  - a door that is not lined up correctly
  - damage around the door, or
  - dents on the interior or exterior of the microwave oven.

If there is any damage, do not operate the microwave oven until a designated service technician has checked it and made any needed repairs.

## Location Requirements

### **WARNING**

#### **Excessive Weight Hazard**

**Use two or more people to move and install microwave oven.**

**Failure to do so can result in back or other injury.**

**IMPORTANT:** The control side of the microwave oven is the heavy side. Handle the microwave oven gently. The weight of the microwave oven is over 47.73 lbs (21.65 kg).

- Place the microwave oven on a cart, counter, table or shelf that is strong enough to hold the microwave oven and the food and utensils you place inside it.
- The microwave oven should be at a temperature above 50°F (10°C) for proper operation.
- Do not block the exhaust vents or air intake openings. Allow a few inches of space at the back and side of the microwave oven where the exhaust vents are located. Blocking the exhaust vents could cause damage to the microwave oven, as well as poor cooking results.
- Make sure the microwave oven legs are in place to ensure proper airflow. If vents are blocked, a sensitive thermal device may automatically turn the microwave oven off. The microwave oven should work properly once it has cooled.

## Electrical Requirements

### **WARNING**



#### **Electrical Shock Hazard**

**Plug into a grounded 3 prong outlet.**

**Do not remove ground prong.**

**Do not use an adapter.**

**Do not use an extension cord.**

**Failure to follow these instructions can result in death, fire, or electrical shock.**

Observe all governing codes and ordinances.

#### **Required:**

- A 120 Volt, 60 Hz, AC only, 20-amp electrical supply with a fuse or circuit breaker.

#### **Recommended:**

- A time-delay fuse or time-delay circuit breaker.
- A separate circuit serving only this microwave oven.

## **GROUNDING INSTRUCTIONS**

#### **■ For all cord connected appliances:**

The microwave oven must be grounded. In the event of an electrical short circuit, grounding reduces the risk of electric shock by providing an escape wire for the electric current. The microwave oven is equipped with a cord having a grounding wire with a grounding plug. The plug must be plugged into an outlet that is properly installed and grounded.

**WARNING:** Improper use of the grounding plug can result in a risk of electric shock. Consult a qualified electrician or serviceman if the grounding instructions are not completely understood, or if doubt exists as to whether the microwave oven is properly grounded.

Do not use an extension cord. If the power supply cord is too short, have a qualified electrician or serviceman install an outlet near the microwave oven.

## **SAVE THESE INSTRUCTIONS**

# INSTRUCTIONS D'INSTALLATION

## Désemballage

1. Enlevez le matériel d'emballage du microondes.
2. Nettoyez l'intérieur avec un linge doux et humide.
3. Vérifiez s'il y a des dommages, comme :
  - une porte qui n'est pas alignée correctement
  - des dommages autour de la porte ou
  - des égratignures à l'intérieur ou à l'extérieur du microondes.S'il y a des dommages, ne pas utiliser le microondes jusqu'à ce qu'un technicien désigné le vérifie et le répare.

## Exigences d'emplacement

### ⚠ AVERTISSEMENT

#### Danger de poids excessif

Nécessite deux personnes ou plus pour installer et déplacer le microondes.  
Ne pas suivre cette directive peut occasionner des blessures au dos ou autres.

**IMPORTANT** : Le panneau de contrôle du microondes se trouve du côté lourd. Manipuler le microondes avec soin. Le microondes pèse près de 47.73 lbs (21.65 kg).

- Placez le microondes sur un charriot, un comptoir, table ou étagère assez solide pour supporter le microondes, les aliments et les ustensiles placés à l'intérieur.
- Le microondes devrait être à une température de 10°C (50°F) pour fonctionner adéquatement.
- Ne pas bloquer l'entrée ou la sortie d'air. Permettre quelques centimètres d'espace à l'arrière et sur les côtés du microondes où se situe la sortie d'air. Bloquer la sortie d'air peut occasionner des dommages au microondes en plus d'une mauvaise cuisson.
- Assurez-vous que les pattes du microondes sont en place pour assurer une bonne circulation d'air. Si les entrées d'air sont bloquées, un capteur thermique du microondes peut l'éteindre automatiquement. Le microondes devrait fonctionner normalement lorsqu'il se refroidit.

## Exigences électriques

### ⚠ AVERTISSEMENT



#### Danger de décharges électriques

Branchez-le dans une prise à trois fils.  
Ne pas enlever la mise à terre du fil d'alimentation.  
Ne pas utiliser un adaptateur.  
Ne pas utiliser de rallonge électrique.  
Ne pas suivre ces instructions peut causer la mort, du feu ou des décharges électriques.

Respectez tous les codes ou ordonnances.

Nécessite :

- Une alimentation électrique de 120 volts, 60 Hz, AC uniquement, de 20 amp avec un fusible ou un disjoncteur.

Recommandé :

- Un fusible ou un disjoncteur à retardement.
- Un circuit dédié au microondes.

## INSTRUCTIONS DE MISE À LA TERRE

- Pour tous les appareils avec fil d'alimentation :  
Le microondes doit avoir une mise à la terre. Lors d'un court-circuit électrique, la mise à la terre réduit le risque de décharges électriques en fournissant un fil échappatoire au courant électrique. Le fil d'alimentation du microondes est équipé d'un fil d'alimentation et d'une fiche électrique avec une mise à la terre. La fiche doit être branchée dans une prise bien installée et mise à la terre.

**AVERTISSEMENT** : Une mauvaise utilisation de la mise à la terre peut causer un risque de décharges électriques. Contactez un électricien ou un réparateur qualifié si vous ne comprenez pas complètement les instructions de mise à la terre ou si un doute persiste que le microondes est bien mis à la terre.  
Ne pas utiliser de rallonge électrique. Si le fil d'alimentation est trop court, communiquez avec un électricien qualifié ou un réparateur pour qu'il installe une prise électrique près du microondes.

**CONSERVEZ CES INSTRUCTIONS.**

## SPECIFICATIONS

POWER SUPPLY		120V AC, 60Hz SINGLE PHASE WITH GROUNDING
MICROWAVE	INPUT POWER	1500 W (Micro)
	ENERGY OUTPUT	1000 W
	FREQUENCY	2,450 MHz
GRILL		1050 W
CONVECTION		1450 W
OUTSIDE DIMENSIONS (W x H x D)		653x432x457 mm (25.69x17x17.7 in)
CAVITY DIMENSIONS (W x H x D)		404x240x376 mm (15.9x9.4x14.8 in)
CAVITY VOLUME		1.3 cu.ft
NET WEIGHT		APPROX. 47.73 lbs
TIMER		99 min 99 sec
POWER LEVELS		10 Levels

\* Specifications are subject to change without notice.

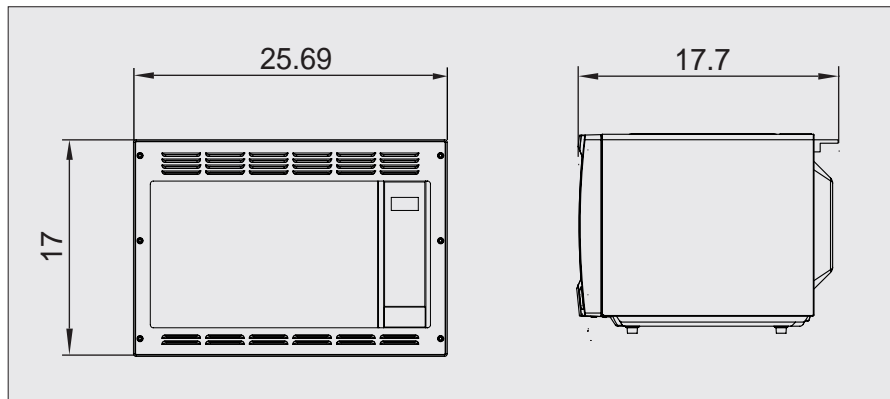

## PARTS AND FEATURES

This manual may cover several different models. The model you have purchased may have some or all of the features shown here. The appearance of your particular model may differ slightly from the illustrations in this manual.

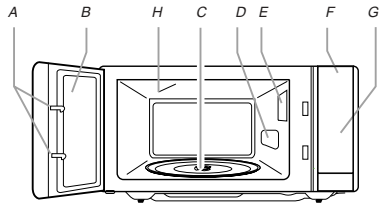

- |                          |                          |
|--------------------------|--------------------------|
| A. Door lock system      | D. Microwave inlet cover |
| B. Metal shielded window | E. Microwave oven light  |
| C. Glass turntable       | F. Display               |
| G. Control panel         | H. Grill Heater          |

### Turntable

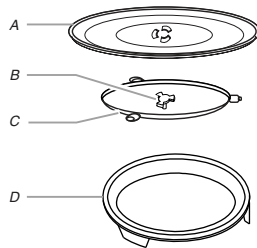

- A. Turntable
- B. Hub
- C. Roller Guide
- D. Baking Plate

The turntable can rotate in either direction to help cook food more evenly. For best cooking results, do not operate the microwave oven without having the turntable in place. See "Assistance or Service" to reorder any of the parts.

To Install:

1. Install the hub into the hole in the center of the microwave oven cavity bottom
2. Place the support on the microwave oven cavity bottom.
3. Place the turntable on the support.

Fit the raised, curved mounds in the center of the turntable bottom between the three spokes of the hub.

## MICROWAVE OVEN CONTROL



### Display

When power is first supplied to the microwave oven, ":" will appear in the display. Reset the clock if needed. See "Clock" section.

When the microwave oven is in use, the display shows cook time remaining. When the microwave oven is not in use, the display shows the time of day (if the clock is set) or Timer countdown.

### Setting The Clock

When the oven is first plugged in, you can set the clock time. To set the clock time by:

1. Press **CLOCK** once to set 24 hour clock, or press **CLOCK** pad again to set 12 hour clock.
2. Use the numeric pads to enter clock time
3. Press **CLOCK** to confirm.

NOTE: This is a 12 and 24 hour clock.

### Timer

- (1) Press **TIMER**.
- (2) Press the number keys and enter the amount of time for the Timer to count down. (the maximum count down time is 99 minutes and 99 seconds)
- (3) Press **START** to confirm the setting and start the timer.
- (4) When the timer is finished the buzzer will ring. The LED display will then return to the current time.

Note: The Kitchen Timer differs from 12-hour system .

### Microwave Cooking

The longest cooking time is 99 minutes and 99 seconds. Microwave cooking allows you to customize cooking power and time.

1. select a power level by pressing the **POWER LEVEL** pad (see the table below).
2. Set the cooking time using the numeric pad
3. Press the **START** pad to start cooking.

Press	Level	Power	
once	10	100%	P-HI
twice	9	90%	P-90
3 times	8	80%	P-80
4 times	7	70%	P-70
5 times	6	60%	P-60
6 times	5	50%	P-50
7 times	4	40%	P-40
8 times	3	30%	P-30
9 times	2	20%	P-20
10 times	1	10%	P-10
11 times	0	0%	P-00

Suppose you want to cook for 5 minute at 60% power level.

1. Press **POWER LEVEL** button 5 times to set 60% power.
2. Press number pads to enter cooking time until the correct cooking time (5:00) is displayed.
3. Press **START** pad.

NOTE:

1. If you want to temporarily stop a cooking session, press the **STOP** pad once, then

you can continue the cooking by pressing **START**; or press the **RESET** twice to cancel the cooking program altogether.

2. After cooking, the system will beep and **End** is displayed. Before starting another cooking session, press any pad to clear the display and reset the system.

### Grill

The longest cooking time is 99 minutes and 99 seconds.

Suppose you want to program grill cooking for 12 minutes.

1. Press **GRILL** button.
2. Use the number pads "1""2" to enter cooking time.
3. Press **START** button.

### Convection

The longest cooking time is 99 minutes and 99 seconds.

During convection cooking, hot air is circulated throughout the oven cavity to make crisp foods quickly and evenly. This oven can be programmed for ten different cooking temperatures. You can press **CONVECTION** to check cooking temperature during cooking.

To Cook with Convection

Press **CONVECTION** pad once and then press the number pads to enter the desired convection temperature.

Suppose you want to cook at 320°F for 40 minutes.

1. Press **CONVECTION** pad
2. Press number pad 6.
3. Press number pads "4""0" to enter cooking time.
4. Press **START** pad.

### To Preheat and Cook with Convection

Your oven can be programmed to combine preheating with convection cooking operations.

Suppose you want to preheat to 340°F and then cook 30 minutes.

1. Press **CONVECTION**.
2. Press number pad 7 to indicate convection temperature 340°F.
3. Press **START** button. "PREH" will flicker in the display until it reaches the designated temperature.
4. Open the door and place container of food at the center of the turntable.
5. Use the number pads to enter cooking time.
6. Press **START** button

---

### Microwave + Grill

The longest cooking time is 99 minutes and 99 seconds.

This feature allows you to combine grill and microwave cooking on two different settings. First, press "Microwave+Grill" button once or twice to choose combination setting 1 or 2, then, enter the desired cooking time. Cook began after pressed the START button

#### COMBINATION 1

30% of time for microwave cooking, 70% for grill cooking.

Suppose you want to set combination 1 cooking for 25 minutes.

1. Press MICRO.+GRILL button once.
2. Use the number pads to enter 25:00.
3. Press START button.

#### COMBINATION 2

55% of time for microwave cooking, 45% for grill cooking.

Suppose you want to set combination 2 cooking for 12 minutes.

1. Press MICRO.+GRILL button twice.
2. Use the number pads to enter 12:00.
3. Press START button.

---

### Microwave + Convection

The longest cooking time is 99 minutes and 99 seconds.

This oven has four pre-programmed settings that make it easy to cook with both convection heat and microwave automatically.

	Number	Temperature (°C)
COMB1	1	230°F
COMB2	2	285°F
COMB3	3	340°F
COMB4	4	390°F

Suppose you want to bake food for 24 minutes on COMB3.

1. Press MICRO.+CONVECTION button once.
2. Use the number pads 1-4 to enter convection temperature. In this case, press number pad 3
3. Use the number pads "2"4"to enter cooking time as desired
4. Press START button to start.

#### NOTE:

You can check the convection temperature by pressing the MICRO.+CONVECTION button during cooking.

---

### Weight Defrost

The oven can defrost food based on the weight you entered. You can set the weight from 1oz~64oz.

Suppose you want to defrost 10oz frozen meat.

1. Press WEIGHT DEFROST button
2. Press number pad "1"0" choose food weight
3. Press START button.

#### NOTE

**Defrost power divides into three stages, each stage needs 1/3 time, after defrosting 2/3 time the system will sound to remind you to turn over the food and pause until you press the button START to enter into the next defrosting stage, and the system resume .**

---

### Multi-Stage Cooking

Your oven can be programmed for up to 3 automatic cooking sequences.

Suppose you want to set the following cooking program.

Microwave cooking



Convection cooking

1. Press POWER LEVEL button to set power level.
2. Use the number pads to enter cooking time.
3. Press CONVECTION pad once.
4. Use the number pads to enter convection temperature.
5. Use the number pads to enter convection cooking time.
6. Press START button.

NOTE: WEIGHT DEFROST and MENU COOK cannot be set in a multi-stage cooking program.

---

### POPCORN

#### For a 3.2 oz. bag of microwave popcorn:

- (1) Touch **POPCORN** once.
- (2) Touch **START**.

#### To change the preset POPCORN time:

- (1) Touch **POPCORN** twice. ENTER TIME appears in display.
- (2) Touch number pads to enter desired cooking time.
- (3) Touch **START**.

**Note:** The longest time you can enter is 99 minutes and 99 seconds. This new setting will be set as the default one until you reset it or next power on.

---

### POTATO

#### For potatoes (8 oz. per entries):

- (1) Touch **POTATO** once for 1 potato.
  - (2) Touch **POTATO** twice for 2 potatoes.
  - (3) Touch **POTATO** 3 times for 3 potatoes.
  - (4) Touch **START**.
- 

### BEVERAGE

#### For cups (7 oz. one cup)

- (1) Touch **BEVERAGE** once for 1 cups beverage.
  - (2) Touch **BEVERAGE** twice for 2 cups beverage.
  - (3) Touch **BEVERAGE** 3 times for 3 cups beverage
  - (4) Touch **START**.
- 

### PIZZA

#### Cook below weight of pizza:

- (1) Touch **PIZZA** once for 5 oz pizza.
- (2) Touch **PIZZA** twice for 11 oz pizza.
- (3) Touch **PIZZA** 3 times for 1LB pizza
- (4) Touch **START**.

---

### SPAGHETTI

#### Cook below weight of spaghetti:

- (1) Touch **SPAGHETTI** once for 4 oz spaghetti.
  - (2) Touch **SPAGHETTI** twice for 7 oz spaghetti.
  - (3) Touch **SPAGHETTI** 3 times for 11oz spaghetti.
  - (4) Touch **START**.
- 

### CHICKEN

#### Cook below weight of chicken:

- (1) Touch **CHICKEN** once for 28 oz chicken.
- (2) Touch **CHICKEN** twice for 35 oz chicken.
- (3) Touch **CHICKEN** 3 times for 42 oz chicken.
- (4) Touch **CHICKEN** 4 times for 50 oz chicken.
- (5) Touch **START**.

**Note:** When hearing DE, turn the food and then press **START** to continue the cook.

---

### CAKE

- (1) Touch **CAKE** pad for 16 oz cake.
  - (2) Touch **START**.
- 

### REHEAT

- (1) Touch **REHEAT** pad for below weight of food.
- (2) Touch **START**.

Press <b>REHEAT</b> times	Weight(oz)
1	7
2	11
3	14
4	18
5	21
6	25
7	28

---

### LOCK FUNCTION FOR CHILDREN

The child lock prevents unsupervised operation by children. Set the function in standby mode.

To set: In standby mode, press and hold **RESET** for 3 seconds. **LOCK** is indicated on the display.

To cancel: press and hold **RESET** for 3 seconds. **LOCK** indication disappears.

---

### TO STOP THE OVEN WHILE THE OVEN IS OPERATING

(1) Press STOP button. You can restart the oven by pressing START pad. Touch RESET button to erase all instructions.

(2) Open the door. You can restart the oven by closing the door and pressing START pad.

**NOTE:** Oven stops operating when door is opened.

---

### OVERHEATING PROTECTION

Digital tube has been shows E 01 and had been "DE- " alarm when the system into the super high temperature protection status. The system into normal standby mode when faults remove and press RESET button.

---

### MICROTHERM PROTECTION

Digital tube has been shows "E 02" when the system enters into the super low temperature protection status. The system enters into normal standby mode when faults remove and press RESET button.

---

### SENSOR MALFUNCTION PROTECTION

In case of short circuit, the system enters into malfunction protection. The display shows E03 with buzzer sounding, press the RESET button, the oven will be back to normal.

---

### COOLING FEATURE

The controlling system of the microwave oven has the feature of cooling. As for any cooking mode which cooking time above 2 minutes, after finishing cooking, the oven fan will work about 3 minutes automatically to cool the oven for prolonging the life of the oven.

# CARE OF YOUR MICROWAVE OVEN

The oven should be cleaned regularly and any food deposits removed.

Failure to maintain the oven in a clean condition could lead to deterioration of the surface that could adversely affect the life of the appliance and possibly result in a hazardous situation.

- 1 Unplug the power cord before cleaning any part of this oven.
- 2 Keep the inside of the oven clean. When food spatters or spilled liquids adhere to oven walls, wipe with a damp cloth. Mild detergent may be used if the oven gets very dirty. The use of harsh detergent or abrasives is not recommended.
- 3 The outside oven surface should be cleaned with soap and water, rinsed and dried with a soft cloth. To prevent damage to the operating parts inside the oven, water should not be allowed to seep into the ventilation openings.
- 4 If the Control Panel becomes wet, clean with a soft, dry cloth. Do not use harsh detergents or abrasives on Control Panel.
- 5 If steam accumulates inside or around the outside of the oven door, wipe with a soft cloth. This may occur when the microwave oven is operated under high humidity conditions and in no way indicates malfunction of the unit.
- 6 It is occasionally necessary to remove the glass tray for cleaning. Wash the tray in warm sudsy water or in a dishwasher.
- 7 The roller guide and oven cavity floor should be cleaned regularly to avoid excessive noise. Simply wipe the bottom surface of the oven with mild detergent water or window cleaner and dry.

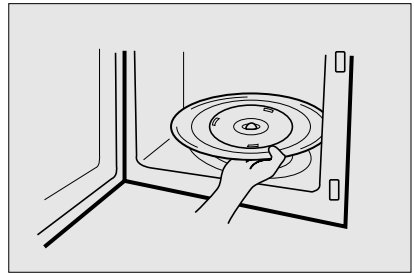

## ROLLER GUIDE

- 1 The ROLLER GUIDE and oven floor should be cleaned frequently to prevent excessive noise.
- 2 The ROLLER GUIDE MUST ALWAYS be used for cooking together with the Glass Tray.

## GLASS TRAY

- 1 DO NOT operate the oven without the Glass Tray in place.
- 2 DO NOT use any other Glass Tray with this oven.
- 3 If Glass Tray is hot, ALLOW TO COOL before cleaning or placing it in water.
- 4 DO NOT cook directly on the Glass Tray.

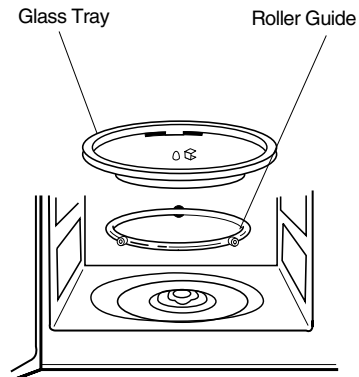

# BEFORE YOU CALL FOR SERVICE

Refer to following checklist, you may prevent an unnecessary service call.

**\* The oven doesn't work :**

1. Check that the power cord is securely plugged in.
2. Check that the door is firmly closed.
3. Check that the cooking time is set.
4. Check for a blown circuit fuse or tripped main circuit breaker in your house.

**\* Sparking in the cavity;**

1. Check utensils. Metal containers or dishes with metal trim should not be used.
2. Check that metal skewers or foil does not touch the interior walls.

If there is still a problem call our customer support department at 888 775-0202 or visit our website at [www.mcappliance.com](http://www.mcappliance.com).

## CARE AND CLEANING

Although your oven is provided with safety features, it is important to observe the following:

1. It is important not to defeat or tamper with safety interlocks.
  - i) Door (bent)
  - ii) Hinges and Hooks (broken or loosened).
  - iii) Door seals and sealing surfaces.
2. Do not place any object between the oven front face and the door or allow residue to accumulate on sealing surfaces. Wipe the sealing area frequently with a mild detergent, rinse and dry. Never use abrasive powders or pads.
3. When opened, the door must not be subjected to strain, for example, a child hanging on an opened door or any load could cause the oven to fall forward to cause injury and also damage to the door. Do not operate the oven if it is damaged, until it has been repaired by a competent service technician. It is particularly important that the oven closes properly and that there is no damage to the:
  4. The oven should not be adjusted or repaired by anyone except a properly trained service technician.
  5. The oven should be cleaned regularly and any food deposits removed;
  6. Failure to maintain the oven in a clean condition could lead to deterioration of the surface that could adversely affect the life of the appliance and possibly result in a hazardous situation.

# QUESTIONS AND ANSWERS

**\* Q : Can the oven be used with the glass tray or roller guide removed?**

A : No. Both the glass tray and roller guide must always be used in the oven before cooking.

**\* Q : Can I open the door when the oven is operating?**

A : The door can be opened anytime during the cooking operation. Then microwave energy will be instantly switched off and the time setting will maintain until the door is closed.

**\* Q : Why do I have moisture in my microwave oven after cooking?**

A : The moisture on the side of your microwave oven is normal. It is caused by steam from cooking food hitting the cool oven surface.

**\* Q : Does microwave energy pass through the viewing screen in the door?**

A : No. The metal screen bounces back the energy to the oven cavity. The holes are made to allow light to pass through. They do not let microwave energy pass through.

**\* Q : Why do eggs sometimes pop?**

A : When baking or poaching eggs, the yolk may pop due to steam build-up inside the yolk membrane. To prevent this, simply pierce the yolk with a toothpick before cooking. Never cook eggs without piercing their shells.

**\* Q : Why is standing time recommended after the cooking operation has been completed?**

A : Standing time is very important. With microwave cooking, the heat is in the food, not in the oven. Many foods build up enough internal heat to allow the cooking process to continue, even after the food is removed from the oven. Standing time for joints of meat, large vegetables and cakes is to allow the inside to cook completely, without overcooking the outside.

**\* Q : What does “standing time” mean?**

A : “Standing time” means that food should be removed from the oven and covered for additional time to allow it to finish cooking. This frees the oven for other cooking.

**\* Q : Why does my oven not always cook as fast as the microwave cooking guide says?**

A : Check your cooking guide again, to make sure you’ve followed directions exactly ; and to see what might cause variations in cooking time. Cooking guide times and heat settings are suggestions, to help prevent over-cooking... the most common problem in getting used to a microwave oven.

Variations in the size, shape and weights and dimensions could require longer cooking time. Use your own judgement along with the cooking guide suggestions to check whether the food has been properly cooked just as you would do with a conventional cooker.

**\* Q : Will the microwave oven be damaged if it operates while empty?**

A : Yes. Never run it empty.

**\* Q : Can I operate my microwave oven without the turntable or turn the turntable over to hold a large dish?**

A : No. If you remove or turn over the turntable, you will get poor cooking results. Dishes used in your oven must fit on the turntable.

**\* Q : Is it normal for the turntable to turn in either direction?**

A : Yes. The turntable rotates clockwise or counterclockwise, depending on the rotation of the motor when the cooking cycle begins.

**\* Q : Can I pop popcorn in my microwave oven? How do I get the best results?**

A : Yes. Pop packaged microwave popcorn following manufacture’s guidelines. Do not use regular paper bags. Use the “listening test” by stopping the oven as soon as the popping slows to a “pop” every 1 or 2 seconds. Do not repop unpopped kernels. Do not pop popcorn in glass cookware.

# USE YOUR MICROWAVE OVEN SAFELY

## General Use

Do not attempt to defeat or tamper with safety interlocks.

Do not place any object between the oven front frame and the door or allow residue to build up on sealing surfaces. Wipe with a mild detergent, rinse and dry. Never use abrasive powders or pads.

Do not subject the oven door to strain or weight such as a child hanging on an open door.

This could cause the oven to fall forward resulting in injury to you and damage to the oven.

Do not operate the oven if door seals or sealing surfaces are damaged; or if door is bent; or if hinges are loose or broken.

Do not operate the oven empty. This will damage the oven.

Do not attempt to dry clothes, newspapers or other materials in the oven. They may catch on fire.

Do not use recycled paper products as they may contain impurities which may cause sparks or fires.

Do not hit or strike the control panel with hard objects. This can damage the oven.

## Food

Never use your microwave oven for home canning. The oven is not designed for proper home canning. Improperly canned food may spoil and be dangerous to consume.

Always use the minimum recipe cooking time. It is better to undercook rather than overcook foods.

Undercooked foods can be returned to the oven for more cooking. If food is overcooked, nothing can be done.

Heat small quantities of food or foods with low moisture carefully. These can quickly dry out, burn or catch on fire.

Do not heat eggs in the shell. Pressure may build up and eggs can explode.

Potatoes, apples, egg yolks and sausages are examples of food with non-porous skins.

These must be pierced before cooking to prevent bursting.

Do not attempt to deep fat fry in your microwave oven.

Always allow a standing time of at least 20 seconds after the oven has been switched off to allow the

temperature to even out, stir during heating, if necessary, and ALWAYS stir after heating. To prevent eruptive boiling and possible scalding, you should put a spoon or glass stick into the beverages and stir before, during and after heating.

Do not leave the oven unattended while popping corn.

Do not pop corn in a paper bag unless it is the commercially prepared Microwave Popcorn product.

The kernels can overheat and ignite a brown paper bag.

Do not put packaged Microwave Popcorn bags directly on the oven tray. Place the package on a microwave safe glass or ceramic plate to avoid overheating and cracking the oven tray.

Do not exceed the Microwave Popcorn manufacturers suggested popping time.

Longer popping does not yield more popcorn but it can result in burning the popcorn or risk of fire. Remember, the Popcorn bag and tray can be too hot to handle.

Remove with caution and use pot holders.

## ARCING

*If you see arcing, touch the **STOP** pad and correct the problem.*

Arcing is the microwave term for sparks in the oven.

Arcing is caused by:

- Metal or foil touching the side of the oven.
- Foil not molded to food (upturned edges act like antennas).
- Metal, such as twist-ties, poultry pins, or gold rimmed dishes, in the microwave.
- Recycled paper towels containing small metal pieces being used in the microwave.



## Limited Warranty

MC Appliance Corporation warrants each new Microwave Oven to be free from defects in material and workmanship, and agrees to remedy any such defect or to furnish a new part(s), at the company's option, for any part(s) of the unit that have failed during the warranty period. Parts and labor expenses are covered on this unit for a period of one year from the date of purchase. A copy of the dated sales receipt or invoice is required to receive warranty service by an authorized service agent.

In addition, MC Appliance Corporation warrants the magnetron (parts only) to be free from defects in material and workmanship for a period of eight years.

The consumer is responsible for all labor and transportation expenses related to the diagnosis and replacement of the magnetron after the initial one-year warranty expires. In the event the unit requires replacement or refund under the terms of this warranty, the consumer is responsible for all transportation expenses to return the unit to our factory prior to receiving a replacement unit or refund. A copy of the dated sales receipt/invoice is required to receive warranty service, replacement or refund.

This warranty covers appliances in use within the continental United States, Alaska, Hawaii and Puerto Rico. This warranty does not cover the following:

- Damages due to shipping damage or improper installation.
- Damages due to misuse or abuse.
- Content losses due to failure of the unit.
- Inside components such as turntable, roller guide, light bulbs, etc.
- Repairs performed by unauthorized service agents.
- Service calls that do not involve defects in material and workmanship such as instructions on proper use of the product or improper installation.
- Replacement or resetting of house fuses or circuit breakers.
- Failure of this product if used for other purposes than its intended purpose.
- Disposal costs for any failed unit not returned to our factory.
- Any delivery/installation costs incurred as the result of a unit that fails to perform as specified.
- Expenses for travel and transportation for product service if your appliance is located in a remote area where service by an authorized service technician is not available.
- The removal and reinstallation of your appliance if it is installed in an inaccessible location or is not installed in accordance with published installation instructions.
- Refunds for non repairable products are limited to the price paid for the unit per the sales receipt.

### Limitations of Remedies and Exclusions:

Product repair in accordance with the terms herein, is your sole and exclusive remedy under this limited warranty. Any and all implied warranties including merchantability and fitness for a particular purpose are hereby limited to one year or the shortest period allowed by law. MC Appliance Corporation is not liable for incidental or consequential damages and no representative or person is authorized to assume for us any other liability in connection with the sale of this product. Under no circumstances is the consumer permitted to return this unit to the factory without the prior written consent of MC Appliance Corporation.

Some states prohibit the exclusion or limitation of incidental or consequential damages, or limitations on implied warranties. This warranty gives you specific legal rights, and you may also have other rights which vary from state to state.

<b>Model</b>	<b>Parts &amp; Labor</b>	<b>Magnetron (Parts Only)</b>	<b>Type of Service</b>
MCC1311ARB/MCC1311ARS	One Year	Eight Years	Carry In

For Service or Assistance please call 888-775-0202 or visit us on the web at [www.mcappliance.com](http://www.mcappliance.com) to request warranty service or order parts.



**CNA International, Inc. d/b/a MC Appliance Corporation. All rights reserved.  
Magic Chef® logo is a registered trademark of CNA International, Inc.**

**[www.mcappliance.com](http://www.mcappliance.com)**

**Printed in China**