

**OWNER'S MANUAL**

# **Master Craft®**

**6000 BTU Window Air Conditioner**  
**8000 BTU Window Air Conditioner**  
**10000 BTU Window Air Conditioner**  
**12000 BTU Window Air Conditioner**

**NOK5W**  
**NOK66**  
**NOK67**  
**NOK68**

**Please read the entire manual carefully  
to ensure proper operation of the product.**

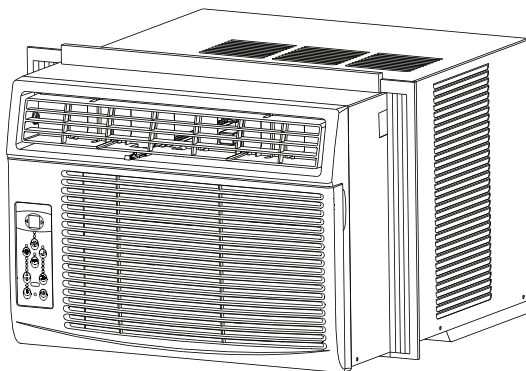

# PRODUCT REGISTRATION

Thank you for purchasing a Master Craft® product. The first step to protect your new product is to complete the product registration on our website: [www.mcappliance.com/register](http://www.mcappliance.com/register). The benefits of registering your product include the following:

1. Registering your product will allow us to contact you regarding a safety notification or product update.
2. Registering your product will allow for more efficient warranty service processing when warranty service is required.
3. Registering your product could act as your proof of purchase in the event of insurance loss.

Once again, thank you for purchasing our product.

# CONTENTS

PRODUCT REGISTRATION .....	2
IMPORTANT SAFETY INSTRUCTIONS.....	4
SPECIFICATIONS.....	6
INSTALLATION INSTRUCTIONS .....	7
OPERATION INSTRUCTIONS .....	13
CARE AND MAINTENANCE.....	18
TROUBLESHOOTING .....	19
LIMITED WARRANTY.....	21

# IMPORTANT SAFETY INSTRUCTIONS

## EXPLANATION OF SYMBOLS

**▲ WARNING:** Hazards or unsafe practices which **COULD** result in severe personal injury or death.

**▲ CAUTION:** Hazards or unsafe practices which **COULD** result in minor personal injury or property damage.

## IMPORTANT SAFETY INSTRUCTIONS

1. Read all instructions before using the appliance.
2. For household use only. **DO NOT** use for other than the intended purpose.
3. **▲ WARNING:** To prevent injuries or property damage, the following instructions must be followed.
4. This appliance should not be operated, cleaned or maintained by anyone that is not able to follow proper safety procedures or does not have experience with this type of equipment, unless under close supervision.
5. **▲ WARNING:** **DO NOT** use in an area where it may be exposed to combustible gases or liquids, as this may cause a fire.
6. **▲ CAUTION:** Installation must be performed according to the installation instructions and **ALWAYS** use the correct tools as specified. Use only accessories and parts included with the appliance. Improper installation can cause water leakage, electrical shock, or fire.
7. Ventilate the room if unit is used near a stove or furnace.
8. **DO NOT** operate in a wet environment, such as a bathroom or laundry room.
9. **DO NOT** stand, sit, or place anything on top of the unit.
10. **DO NOT** let children operate or play on or around the air conditioner. Children should be supervised around the unit at all times.
11. **▲ CAUTION:** The power cord is equipped with a 3-prong grounding plug to protect against shock hazards. **ALWAYS** plug cord into a dedicated, properly installed and grounded 3-prong wall receptacle. Refer to the manufactures rating label for electrical and other technical data specific to this unit.
12. **DO NOT** modify or cut the power cord, or use any other cord or plug. If the cord or plug is damaged, **DO NOT** use. Contact customer service or a qualified service technician for replacement or repair.
13. **DO NOT** run cord under carpeting, throw rugs, runners, or similar coverings. **DO NOT** route cord under furniture, appliances, or any heavy object. Place the cord where it will not be tripped over, way from any sources of heat.
14. **DO NOT** start or stop the unit by turning the power on or off.
15. **DO NOT** insert or pull out the plug, or operate the unit with wet hands.
16. **DO NOT** remove the plug by pulling the cord.
17. **ALWAYS** turn off and unplug the unit when not in use.
18. **DO NOT** obstruct the unit to ensure proper function and safety.
19. **DO NOT** insert your finger or other foreign objects into grills or openings.
20. **▲ CAUTION:** **ALWAYS** turn off and unplug the unit prior to cleaning or maintenance.

21. Contact customer service or an authorized service technician for repair or maintenance of this unit. DO NOT try to take apart or repair the unit by yourself.
22. Turn off and unplug the unit if strange sounds, smells, or smoke come from it.
23. DO NOT open or remove any of the panels of the unit while it is operating or plugged in.
24. If water spills into the unit, turn it off, unplug it, and contact a qualified service technician.
25. DO NOT direct airflow at room occupants, pets, or plants.
26. ALWAYS insert the filters securely. Clean filter once every two weeks, and avoid touching any metal parts of the unit while changing or cleaning.
27. DO NOT disassemble or modify the unit in any way.
28. DO NOT drink water condensation from the unit.
29. Periodically check the installation bracket for damage or wear due to exposure. A damaged bracket could result in the unit falling from the window.

**READ AND FOLLOW THIS  
SAFETY INFORMATION CAREFULLY  
SAVE THESE INSTRUCTIONS**

# SPECIFICATIONS

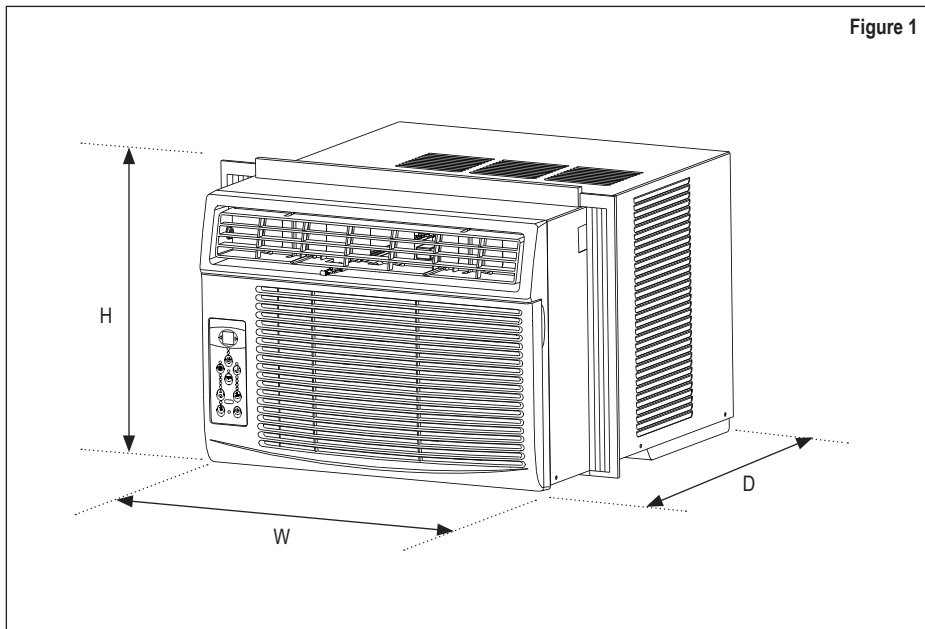

Model	MCRAC6KEWM	MCRAC8KEWM	MCRAC10KEWM	MCRAC12KEWM
Dimensions (W x D x H)	18.5" x 15.7" x 13.4"	18.5" x 17.5" x 13.4"	19.0" x 21.5" x 14.6"	19.0" x 21.5" x 14.6"
BTU	6,000	8,000	10,000	12,000
Voltage	115V / 60Hz	115V / 60Hz	115V / 60Hz	115V / 60Hz
Watts	490	666	833	1000
Refrigerant Type	R410A	R410A	R410A	R410A
EER	12.2	12.0	12.0	12.0

## OPERATING TEMPERATURE RANGE

Outdoor Temperature	64-109°F (18-43°C)
Indoor Temperature	62-90°F (17-32°C)

# INSTALLATION INSTRUCTIONS

## BEFORE YOU BEGIN

▲ **IMPORTANT:** Save these instructions for local inspectors use.

▲ **IMPORTANT:** Observe all governing codes and ordinances.

▲ **NOTE TO CONSUMER:** Keep these instructions for future reference.

▲ **NOTE TO INSTALLER:** Be sure to leave these instructions with the Consumer.

- Read these instructions completely and carefully.
- Completion Time: Approximately 1 hour
- Skill Level: Installation of this appliance requires basic mechanical skills. We recommend that two people install this product.
- Proper installation is the responsibility of the installer. Product failure due to improper installation is not covered under the Warranty. You **MUST** use all supplied parts and use proper installation procedures as described in these instructions when installing this air conditioner.

## WINDOW REQUIREMENTS

Your air conditioner is designed to install in standard double hung windows with openings of 23 to 36" (584mm to 914mm) wide and at least 14" (356mm) high for 6,000 -8,000 btu units, and 15-1/2" (394mm) high for 10,000 – 12,000 btu units.

▲ **CAUTION:** DO NOT, under any circumstances, cut or remove the third (ground) prong from the power cord.

▲ **CAUTION:** DO NOT change the plug on the power cord of the air conditioner.

▲ **CAUTION:** Aluminum house wiring may present special problems. Consult a qualified electrician.

▲ **CAUTION:** When handling unit, be careful to avoid cuts from sharp metal edges and aluminum fins on front and rear coils.

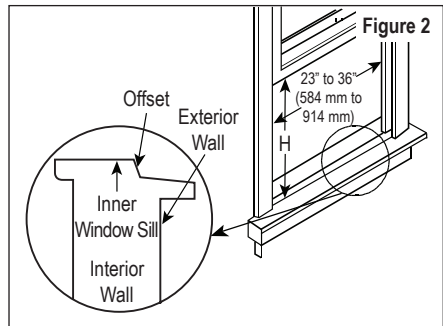

Model	5000-8000 BTU/h	10000-12000 BTU/h
H	14" (356 mm)	15-1/2" (394 mm)

## REQUIRED TOOLS (NOT INCLUDED)

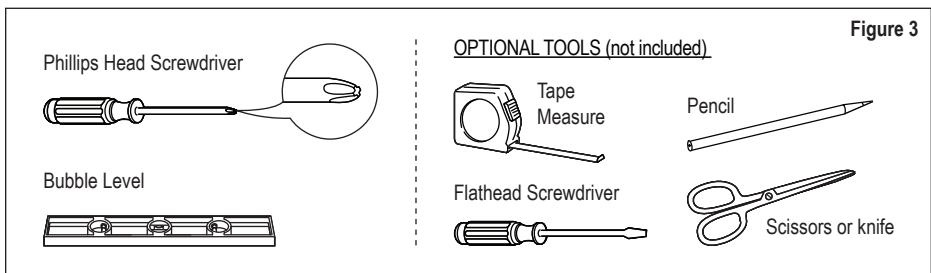

**▲ NOTE:** Save the carton and these Installation Instructions for future reference. The carton is the best way to store unit during winter, or when not in use.

## PREPARE THE WINDOW

The lower sash must open sufficiently to allow a clear vertical opening of 14" (356mm) high for 6,000 -8,000 btu units, and 15-1/2" (394mm) high for 10,000 – 12,000 btu units. Side louvers and the rear of the AC must have clearance to allow enough airflow through the condenser for heat removal. The rear of the unit must be outdoors, not inside a building or garage.

- a. 3/4" or 1/2" Screws (7)
- b. Frame Lock (2)
- c. Sash Lock (1)
- d. Window Sash Seal Foam (1)
- e. 10" x 3/4" x 1-1/2" Weather Stripping (5)
- f. 3/8" Screws (4)
- g. Top Rail (1)
- h. R1 Hardware (2)

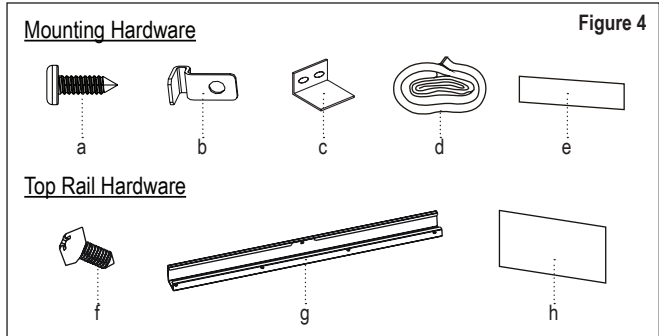

**▲ NOTE:** Weather stripping is only for Energy star models.

## PREPARE THE AIR CONDITIONER

1. Remove the air conditioner from the carton and place on a flat surface.
2. Remove top rail (g) and R1 hardware (h) from the packaging material as shown in Figure 5. (R1 hardware is only included for Energy star models.)
3. Align the holes in the top rail (g) with those in the top of the unit as shown in Figure 6.
4. Secure the top rail (g) to the unit with the 3/8 Screws (f) as shown in Figure 7.

**▲ NOTE:** For safety reasons, all four(4) screws MUST be securely fastened.

**▲ NOTE:** The top rail hardware and Figure 5, Figure 6 and Figure 7 are not applicable to the units with more than 10000Btu/h. Before installing unit, the top rail must be assembled on the unit (For <10000Btu/h models only).

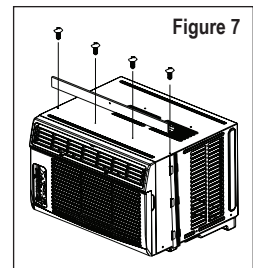
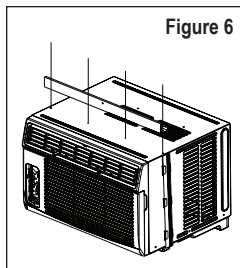
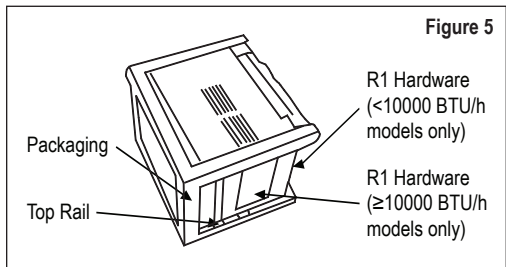



## INSTALL THE ACCORDIAN PANELS

**▲ NOTE:** Top rail and Sliding Panels at each side are offset to provide the proper pitch to the rear of (5/16"). This is necessary for proper condensed water utilization and drainage. If you are not using the Side Panels for any reason, this pitch to the rear must be maintained.

1. Place unit on floor, a bench or a table. Hold the Accordion Panel in one hand and gently pull back the center beyond the ends of the top and bottom frame to free the open end. See Figure 8.
2. Slide the free end "I" section of the panel into the cabinet as shown in Figure 9. Slide the panel all the way down. Be sure to leave enough space to slip the top and bottom of the frame into the rails of the cabinet.

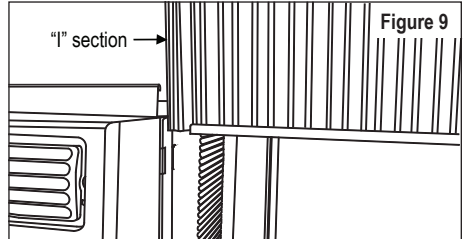
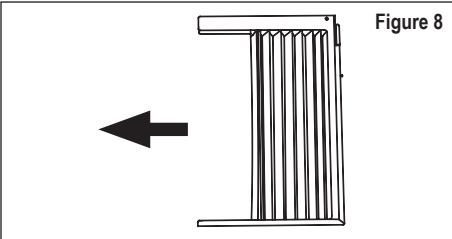

3. Once the panel has been installed on the side of the cabinet, make sure it sits securely inside the frame channel by making slight adjustments. Slide the top and bottom ends of the frame into the top and bottom rails of the cabinet as seen in Figure 10.
4. Slide the panel all the way in to the top and bottom rails on the unit and repeat for the other side. See Figure 11.

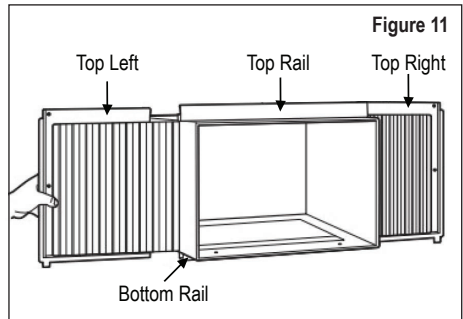
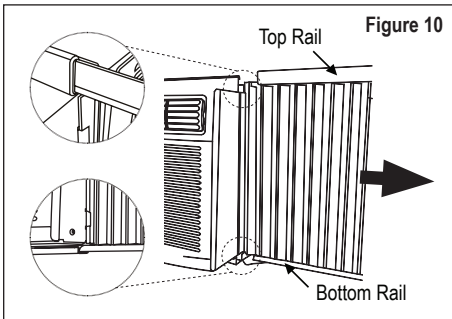

## SECURE THE ACCORDIAN PANELS

1. Keep a firm grip on the air conditioner, and carefully place the unit into the window opening so the bottom of the air conditioner frame is against the window sill (Figure 12). Carefully close the window behind the top rail of the unit. It is recommended to have two people install the air conditioner.

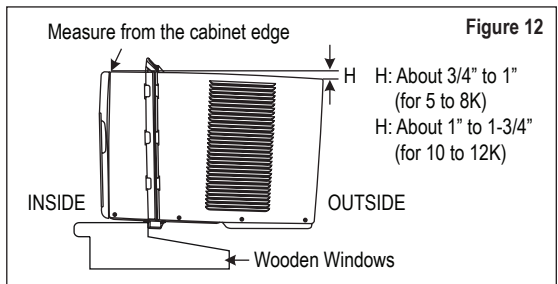

**▲ NOTE:** Check that the air conditioner is tilted back about 3° to 4° down towards the outside (Figure 12). After proper installation, if condensation does not drain from the overflow drain hole during normal use, correct the angle of the slope.

2. Extend the side panels out against the window frame (Figure 13).

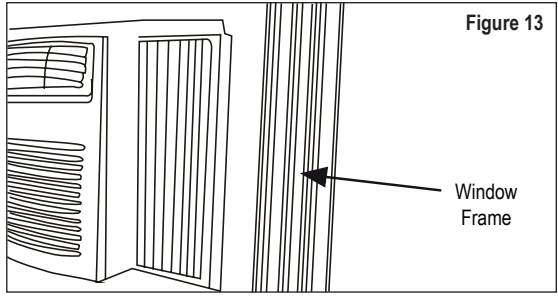

## INSTALL SUPPORT BRACKET

1. Place the frame lock (b) between the frame extensions and the window sill (See Figure 14). Drive 3/4" (19mm) or 1/2" (12.7mm) locking screws (a) through the frame lock and into the sill.

**▲ NOTE:** To prevent window sill from splitting, drill 1 / 8" (3mm) pilot holes before driving screws.

2. Drive 3/4" (19mm) 1/2" (12.7mm) locking screws (a) through frame holes into window sash (See Figure 15).

**▲ NOTE:** To prevent window sill from splitting, drill 1 / 8" (3mm) pilot holes before driving screws.

3. To secure lower sash in place, attach right angle sash lock (c) with 3/4" (19mm) or 1/2" (12.7mm) (a) screw as shown (See Figure 16).
4. Cut the Window Sash Seal foam (d) and insert it in the space between the upper and lower sashes (See Figure 17).

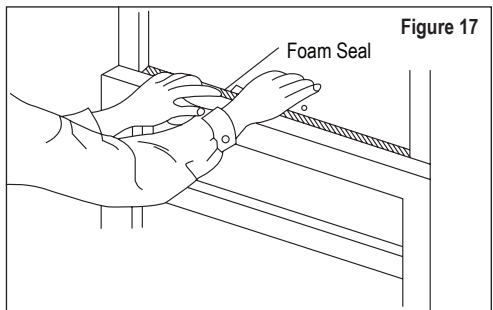
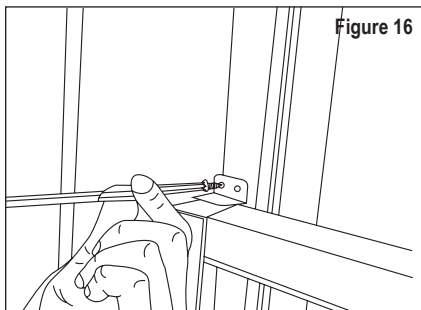
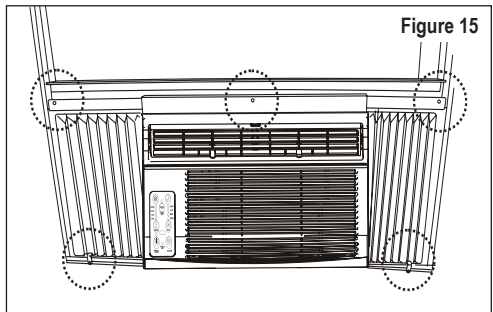
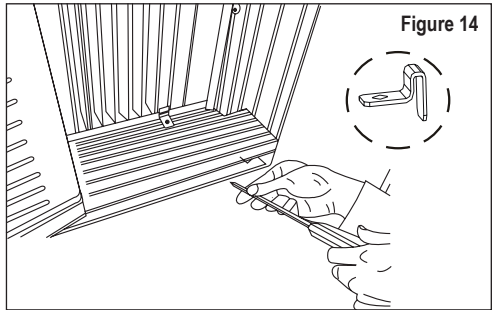

## INSTALL R1 HARDWARE (ONLY APPLICABLE TO ENERGY STAR MODELS)

In order to minimize air leaks and ensure optimal insulation, it is necessary to install the included R1 hardware (h) to the side curtain. Follow the instructions below.

1. After the unit is installed to the window, measure the inner width of the side curtain as shown in Figure 18.
2. Mark a line on the provided R1 insulation panel (h) according to a length  $1/8$  (3mm) less than the measured width in step 1, then cut the R1 insulation panel along the line with a knife or scissors. (See Figure 19.)
3. Slide the R1 insulation panel (h) into the side curtain, the side with pattern should facing the indoor side. (See Figure 20.)
4. Repeat for the other side.

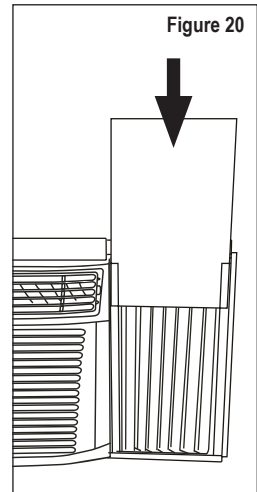
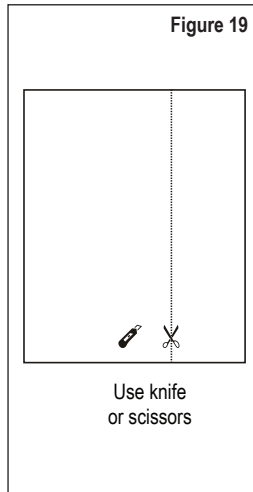
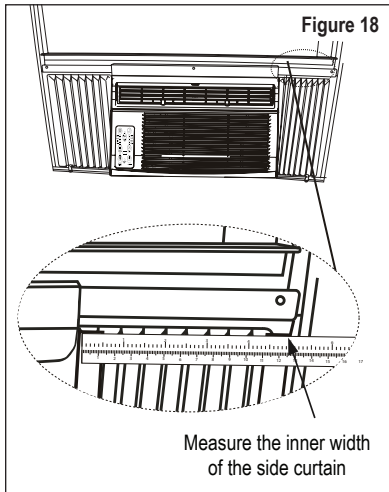

## INSTALL WEATHER STRIPPING (ONLY APPLICABLE TO ENERGY STAR MODELS)

In order to minimize air leaks between the air conditioner and the window opening, trim the weather stripping (e) to the proper length, peel off the protective backing and plug any gaps if needed (See Figure 21).

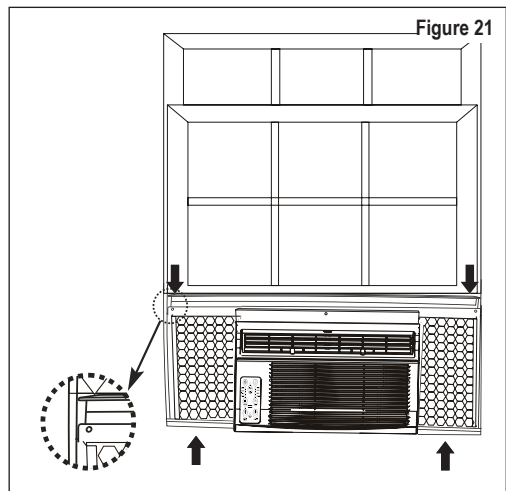

## IF AC IS BLOCKED BY STORM WINDOW

If a storm window prevents the air conditioner from properly fitting into the space and it cannot be removed, use a board with a width of at least 1-1/2" and a thickness that allows clearance for the installation of the unit (Figure 22). Be sure the drain holes or slots for the storm window frame are not caulked or painted shut. Rain water or condensation must be allowed to drain out.

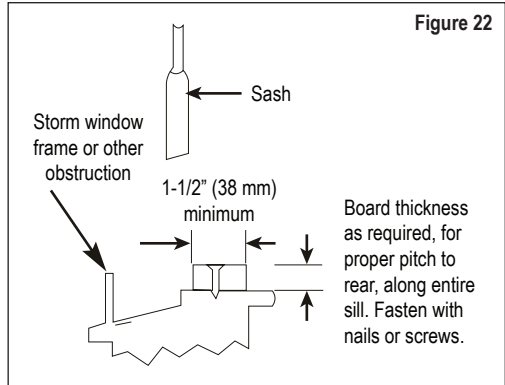

## REMOVING AC FROM WINDOW

Turn the unit off and disconnect power cord. Remove sash seal from between windows, and unscrew safety sash lock. Remove all screws installed through frame and frame lock. Remove the R1 Panel and slide the side panels into frame. Keeping a firm grip on air conditioner, raise sash and carefully remove. Be carefully not to spill any remaining water while lifting unit from window. Store parts with air conditioner. It is recommended to have two people to remove the air conditioner from the window.

# OPERATING INSTRUCTIONS

## OPERATION OF CURRENT DEVICE

The power supply cord contains a current device that senses damage to the power cord. To test your power supply cord do the following:

1. Plug in the Air Conditioner.
2. The power supply cord will have TWO buttons on the plug head. Press the TEST button, you will notice a click as the RESET button pops out.
3. Press the RESET button, again you will notice a click as the button engages.
4. The power supply cord is now supplying electricity to the unit. (On some products this it also indicated by a light on the plug head.)

▲ **NOTE:** DO NOT use this device to turn the unit on or off.

▲ **NOTE:** ALWAYS make sure the RESET button is pushed in for correct operation.

▲ **NOTE:** The power supply must be replaced if it fails reset when either the TEST button is pushed, or it cannot be reset. A new one can be obtained from the product manufacturer.

▲ **NOTE:** If power supply cord is damaged, it cannot be repaired. It MUST be replaced by one obtained from the product manufacturer.

Before you begin, thoroughly familiarize yourself with the control panel as shown below and all its functions then follow the symbol for the functions you desire. The unit can be controlled by the unit control alone or with the remote.

▲ **NOTE:** All illustrations in this manual are for explanation purpose only. Your air conditioner may be slightly different.

## CONTROL PANEL

### TO TURN UNIT ON OR OFF

Press the (⏻) (ON/OFF) button to turn the unit on or off.

▲ **NOTE:** The unit will automatically initiate the Energy Saver function under Cool, Dry, Auto modes (only when set to Auto-Cooling and Auto-Fan).

### TO CHANGE TEMPERATURE SETTING

Press (▶) / (◀) (UP/DOWN) button to change temperature setting.

▲ **NOTE:** Press or hold either UP (▶) or DOWN (◀) button until the desired temperature is seen on the display. This temperature will be automatically maintained anywhere between 62°F (17°C) and 86°F (30°C). If you want the display to read the actual room temperature, see To Operate on Fan Only section.

### TO ADJUST FAN SPEEDS

Press (⌚) (FAN) button to select the Fan Speed in four steps-Auto, Low, Med or High. Each time the button is pressed, the fan speed mode changes. On Dry mode, the fan speed is controlled at Low automatically.

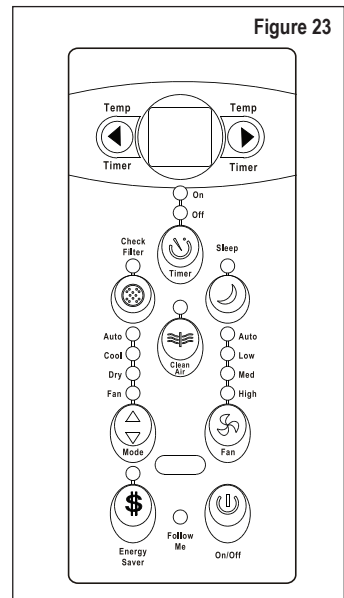

## SLEEP FEATURE



Press  (Sleep) button to initiate the sleep mode. The selected temperature will increase by 2°F/1 or 2°C 30 minutes after the mode is selected, then another 2°F/ 1 or 2°C after an additional 30 minutes. This new temperature will be maintained for 6 hours and then return to the original temperature setting. The Sleep mode program can be cancelled at any time during operation by pressing the Sleep button again.

## TO SELECT THE OPERATING MODE

To choose operating mode, press  (Mode) button. Each time you press the button, the selected mode will cycle through Auto, Cool, Dry and Fan. The indicator light will be illuminated and remain on once the mode is selected. The unit will automatically initiate the Energy Saver function under Cool, Dry, Auto modes (only when set to Auto-Cooling and Auto-Fan).

1. **AUTO MODE:** When you set the air conditioner to AUTO mode, it will automatically select cooling or fan only operation depending on what temperature you have selected and the room temperature. The air conditioner will control room temperature automatically based on the temperature point set by you. When set on AUTO, the fan speed cannot be adjusted and will run as needed based on the room temperature.
2. **COOL MODE:** When the unit is set on Cool Mode it will run the fan and compressor to reach and maintain the set temperature.
3. **DRY MODE:** When set to Dry Mode, the air conditioner will operate as a dehumidifier. Since the space is enclosed, and the condenser is operational, there will be some degree of cooling.
4. **FAN ONLY MODE:** Use this function to circulate air without cooling it. ALWAYS be sure to open the vent during this function, which is kept closed during cooling (for maximum cooling efficiency.) Use the fan button to set the desired fan speed. During set to Fan Only, the display will show the actual room temperature, not the set temperature, and the temperature setting cannot be adjusted.

## OTHER FUNCTIONS

- **ENERGY SAVER:** Press  (Energy Saver) button to set this function. This function is available in COOL, DRY, AUTO (AUTO-COOLING and AUTO-FAN only) modes. The fan will continue to run for 3 minutes after the compressor shuts off. The fan then cycles on for 2 minutes at 10 minute intervals until the room temperature is above the set temperature, at which time the compressor turns back on and cooling starts again.
- **TIMER:** With the unit is on or off, first press  (Timer) button. The TIMER ON indicator light will illuminate to indicate the Auto Start program is initiated and the display will show the time currently set for the air conditioner to automatically start.

When the time of TIMER ON is displayed press the Timer button again and the TIMER OFF indicator light will illuminate to indicate the Auto Stop program is initiated. Press or hold the UP or DOWN button to change the Auto time by 0.5 hour increments, up to 10 hours, then at 1 hour increments up to 24 hours.

The selected time will show on the display for 5 seconds, and the system will automatically revert back to display the previous temperature setting or room temperature when the unit is on. If the unit is off, there is no display. The control will count down the time remaining until start.

Turning the unit ON or OFF at any time or setting the timer to 0.0 will cancel the Auto Start/Stop timed program.

**▲ NOTE:** The timer will count down the time displayed, and does not operate based on the actual time of day. Setting the Timer On to 4 and Timer Off to 8 means the air conditioner will turn on 4 hours from the time the auto-start function is initiated, and turn off after another 4 hours.

## FOLLOW ME (Only for models with this feature)

The remote control serves as a remote thermostat allowing for the precise temperature control at its location. Point the remote control towards the unit and press the Follow Me button. The remote will display the temperature at its actual location, and send a signal to the air conditioner every 3 minutes until the Follow Me button is pushed again, turning the feature off. If the air conditioner does not receive a signal from the remote for 7 minutes, the unit will beep and the feature will automatically shut off.

This feature can be activated from the remote control ONLY.

## CHECK FILTER

Press  (Check Filter) to initiate this feature. This feature is a reminder to clean the Air Filter for more efficient operation. The LED light will illuminate after 250 hours of operation. To reset after cleaning the filter, press the Check Filter button and the light will go off.

## DISPLAYS

Shows the set temperature in °F or °C and the Auto-timer settings. While on Fan only mode, it shows the room temperature.

The control is capable of displaying temperature in degrees Fahrenheit (°F) or Celsius (°C). To change from one to the other, press and hold the Left and Right Temp/Timer buttons at the same time for 3 seconds.

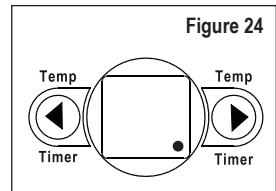

## ERROR CODES

- AS: Room temperature sensor error. Unplug the unit and plug it back in. If error persists, call for service.  
**▲ NOTE:** In Fan only mode it will display “LO” or “HI”
- ●: Evaporator temperature sensor error-Unplug the unit and plug it back in. If error persists, call for service.  
**▲ NOTE:** “●”is displayed as shown in Figure 24.
- HS: Electric heating sensor error. Unplug the unit and plug it back in. If error persists, call for service.

## REMOTE CONTROL

**▲ NOTE:** Buttons design is based on a typical model and may be slightly different from the actual one you purchased. All the functions described are accomplished by the air conditioner. If the unit does not have a feature indicated by a button on the remote, pushing the button will not do anything. When there are differences between Remote Controller instructions and the Use and Care Manual on function description, the description in the Use and Care Manual shall prevail.

- ON/OFF: Operation starts when button is pressed and stops when it is pressed again.  
**▲ NOTE:** If the unit has ENERGY SAVER function, it will automatically initiate under Cool, Dry, and Auto (only Auto-Cooling and Auto-Fan) modes.
- TEMP DOWN: Push this button to decrease the indoor temperature setting.
- TIMER: Push this button to activate the Auto Start or Auto Stop program.

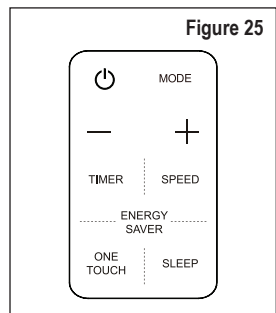

- **ONE TOUCH:** Push to automatically start the COOL function with the fan set to AUTO and the temperature set to 80°F (26°C). TIMER function will be cancelled if set. (Not available on all models.)
- **MODE:** Press to select desired operation mode.
- **TEMP UP:** Push this button to increase the indoor temperature setting.
- **FAN SPEED:** Use to select the desired fan speed.
- **SLEEP:** Press this button to activate the Sleep mode. This function is available on COOL or AUTO mode only. For operation details, see SLEEP feature.
- **ENERGY SAVER:** Press this button to activate the Energy saving mode and again to stop it. (Not available on all models.)

## BATTERY INSTALLATION

1. Insert a coin into the groove on the battery cover, and turn clockwise 45 degrees. Make sure that the groove is aligned with the "Unlock" sign and remove the battery cover (See Figure 26).
2. Install Lithium battery (CR2025) into the remote control, with the positive (+) side up.
3. Replace the battery cover, make sure the battery cover groove is aligned with the "Unlock" sign. Insert a coin into the groove and press it gently, then turn counter clockwise 45 degrees. Make sure the groove is aligned with the "Lock" sign.

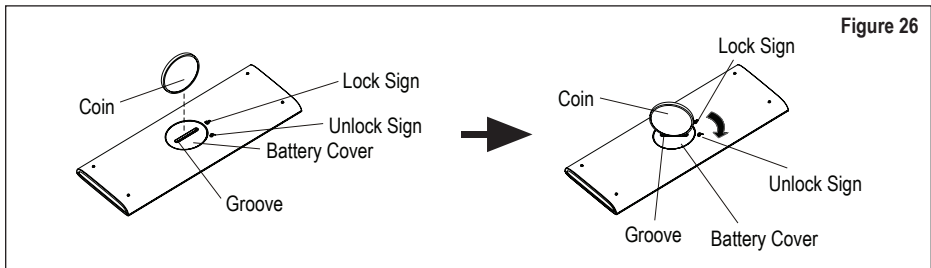

### ▲ WARNING:

- Battery must be disposed of properly. DO NOT short circuit or dispose of in the fire.
- Keep batteries out of the reach of children.
- DO NOT ingest, or allow others to ingest the battery.
- Non-rechargeable batteries are not to be recharged.
- Exhausted batteries are to be removed from the product.



**▲ WARNING:**

- Chemical Burn Hazard. Keep batteries away from children.
- This product contains a lithium button/coin cell battery. If a new or used lithium button/coin cell battery is swallowed or enters the body, it can cause severe internal burns and can lead to death in as little as 2 hours. Always completely secure the battery compartment. If the battery compartment does not close securely, stop using the product, remove the batteries, and keep it away from children. If you think batteries might have been swallowed or placed inside any part of the body, seek immediate medical attention.
- The cells shall be disposed of properly, including keeping them away from children. Even used cells may cause injury.

**▲ CAUTIONS**

- The air conditioner will not operate if curtains, doors or other materials block the signals from the remote controller to the unit.
- Prevent any liquid from falling into the remote controller. Do not expose the remote controller to direct sunlight or heat.
- If the infrared signal receiver on the indoor unit is exposed to direct sunlight, the air conditioner may not function properly. Use curtains to prevent the sunlight from falling on the receiver.
- If other electrical appliances react to the remote controller, either move these appliances or consult your local dealer.

**▲ NOTE:**

-Buttons design is based on typical model and might be slightly different from the actual one you purchased, the actual shape shall prevail.

-All the functions described are accomplished by the unit, if the unit has no this feature, there is no corresponding operation happened when press the relative button on the remote controller.

-When there are wide differences between Remote controller Illustration and USERS MANUAL on function description, the description on USERS MANUAL shall prevail.

-The device could comply with the local national regulations. In Canada, it should comply with CAN ICES-3(B)/NMB-3(B). In USA, this device complies with part 15 of the FCC Rules.

Operation is subject to the following two conditions: (1) This device may not cause harmful interference, and (2) this device must accept any interference received, including interference that may cause undesired operation.

-This equipment has been tested and found to comply with the limits for a Class B digital device, pursuant to part 15 of the FCC Rules. These limits are designed to provide reasonable protection against harmful interference in a residential installation. This equipment generates, uses and can radiate radio frequency energy and, if not installed and used in accordance with the instructions, may cause harmful interference to radio communications. However, there is no guarantee that interference will not occur in a particular installation. If this equipment does cause harmful interference to radio or television reception, which can be determined by turning the equipment off and on, the user is encouraged to try to correct the interference by one or more of the following measures:

- Reorient or relocate the receiving antenna.
- Increase the separation between the equipment and receiver.
- Connect the equipment into an outlet on a circuit different from that to which the receiver is connected.
- Consult the dealer or an experienced radio/TV technician for help. Changes or modifications not approved by the party responsible for compliance could void users authority to operate the equipment.

## DIRECTIONAL AIR LOUVERS

The louvers will allow you to direct the air flow Up or Down (on some models) and Left or Right. Pivot horizontal louvers until the desired Up/Down direction is obtained. Move the Levers from side to side until the desired Left/Right direction is obtained.

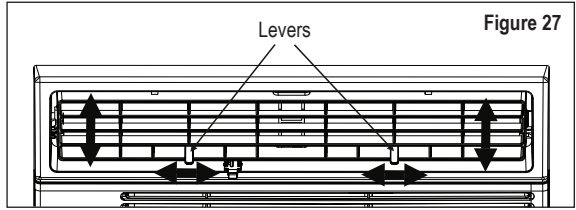

## FRESH AIR VENT CONTROL (ON 10000~12000 BTU/H MODELS)

The Fresh Air Vent allows the air conditioner to:

1. Recirculate inside air: Vent Closed (See Figure 28.)
2. Draw fresh air into the room: Vent Opened (see Figure 29.)
3. Exchange air from the room and draws fresh air into the room: Vent and Exhaust Opened (see Figure 30.)

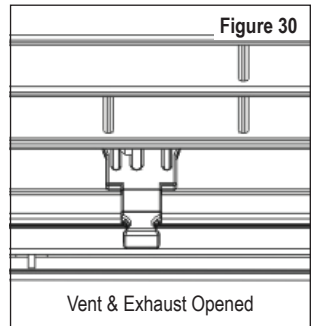
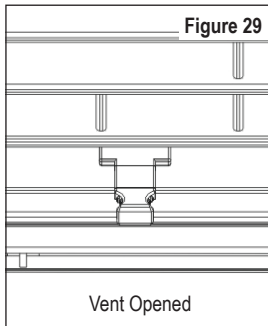
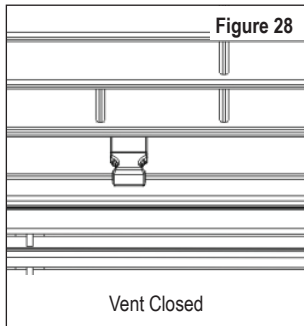

# CARE AND MAINTENANCE

**▲ CAUTION:** Clean your air conditioner regularly to keep it looking new. Be sure to unplug the unit before cleaning to prevent shock or fire hazards.

## CLEANING THE AIR FILTER

The air filter should be checked at least once a month to see if cleaning is necessary. Trapped particles in the filter can build up and cause an accumulation of frost on the cooling coils.

- Push the vent handle to the Vent Closed position (when applicable). Open the front panel.
- Take the filter by the center and pull up and out.
- Wash the filter using liquid dishwashing detergent and warm water. Rinse filter thoroughly. Gently shake excess water from the filter. Be sure the filter is thoroughly dry before replacing. Alternatively, you may carefully vacuum the filter clean.

**▲ NOTE:** NEVER use hot water over 104°F (40°C) to clean the air filter. NEVER attempt to operate the unit without the air filter.

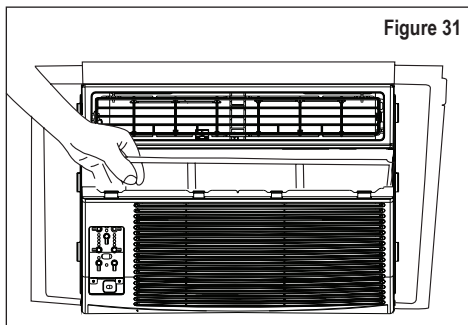

## CLEANING THE CABINET

- Be sure to unplug the air conditioner to prevent shock or fire hazard. The cabinet and front may be dusted with an oil-free cloth or washed with a cloth dampened in a solution of warm water and mild liquid dishwashing detergent. Rinse thoroughly and wipe dry.
- NEVER use harsh cleaners, wax or polish on the cabinet front.
- Be sure to wring excess water from the cloth before wiping around the controls. Excess water in or around the controls may cause damage to the air conditioner.

## WINTER STORAGE

If you plan to store the air conditioner during the winter, remove it carefully from the window according to the installation instructions. Cover it with plastic or return it to the original carton.

# TROUBLESHOOTING

Please check the following before calling for service.

Problem	Solution
Air conditioner does not start.	Wall plug disconnected. Push plug firmly into wall outlet.
	House fuse blown or circuit breaker tripped. Replace fuse with time delay type or reset circuit breaker.
	Plug Current Device Tripped. Press the RESET button.
	Power is OFF. Turn power ON.
Air from unit does not feel cold enough.	Room temperature below 62°F (17°C). Cooling may not occur until room temperature rises above 62°F (17°C).
	Temperature sensing behind air filter element touching cold coil. Keep it from the cold coil.
	Set to a Lower temperature.
	Compressor stopped when changing modes. Wait for 3 minutes after set to the COOL mode.
Air conditioner cooling, but room is too warm. Ice forming on cooling coil behind decorative front.	Outdoor temperature below 64°F (18°C). To defrost the coil, set FAN ONLY mode.
	Air filter may be dirty. Clean filter. Refer to Care and Cleaning section. To defrost, set to FAN ONLY mode.
	Thermostat set too cold for night-time cooling. To defrost the coil, set to FAN ONLY mode. Then, set temperature to a higher setting.
Air conditioner cooling, but room is too warm. NO ice forming on cooling coil behind decorative front.	Dirty air filter- air restricted. Clean air filter. Refer to Care and Cleaning section.
	Temperature is set too High, set temperature to a Lower setting.
	Air directional louvers positioned improperly. Position louvers for better air distribution.
	Front of unit is blocked by drapes, blinds, furniture, etc. restricting air distribution. Clear blockage in front of unit.
	Doors, windows, registers, etc. open allowing cold air to escape. Close doors, windows, registers, etc.
	Unit recently turned on in hot room. Allow additional time to remove stored heat from walls, ceiling, floor and furniture.
Air conditioner turns on and off rapidly.	Dirty air filter restricting air flow. Clean air filter.
	Outside temperature extremely hot. Set FAN speed to a higher setting to bring air past cooling coils more frequently.
Noise when unit is cooling.	Air movement sound. This is normal. If too loud, set to a slower FAN setting.
	Window vibration from improper installation. Refer to installation instructions or check with installer.
Water dripping INSIDE when unit is cooling.	Improper installation. Tilt air conditioner slightly to the outside to allow water drainage. Refer to installation instructions - check with installer.
Water dripping OUTSIDE when unit is cooling.	Unit removing large quantity of moisture from humid room. This is normal during excessively humid days.

Remote Sensing Deactivating Prematurely (some models)	Remote control not within range. Place remote control within 20 feet & 180° radius of the front of the unit.
	Remote control signal obstructed. Remove obstruction.
Room too cold	Set temperature is too low. Increase set temperature.

- If the unit shuts off due to the power cut, it will restart with the previous function setting automatically when the power resumes.
- The Cool circuit has an automatic 3 minute time delayed start if the unit is turned off and on quickly. This prevents overheating of the compressor and possible circuit breaker tripping. The fan may continue to run during this time.

## NORMAL SOUNDS

Gurgling or hissing noises may be heard due to refrigerant passing through evaporator during normal operation.

- At the front of the unit, you may hear the sound of rushing air being moved by the fan.
- High efficiency compressor may have a high pitched chatter during the cooling cycle.
- Unit may vibrate and make noise due to wall or window construction or incorrect installation.
- Droplets of water hitting condenser during normal operation may cause pinging or switching sounds.

# Master Craft®

## LIMITED WARRANTY

MC Appliance Corporation warrants each new ROOM AIR CONDITIONER to be free from defects in material and workmanship and agrees to remedy any such defect or to furnish a new part(s) (at the company's option) for any part(s) of the unit that has failed during the warranty period. Parts and labor expenses are covered on this unit for a period of one year from the date of purchase. In addition, MC Appliance Corporation warrants the compressor (parts only) to be free from defects in material and workmanship for a period of 5 years. The consumer is responsible for all labor and transportation expenses related to the diagnosis and replacement of the compressor after the initial one-year warranty expires. In the event that the unit requires replacement or refund under the terms of this warranty, the consumer is responsible for all transportation expenses to return the unit to our factory prior to receiving a replacement unit or refund. A refund or replacement will be issued at the discretion of MC Appliance Corporation. A copy of the dated sales receipt/invoice is required to receive warranty service or a refund.

This warranty covers appliances in use within the contiguous United States, Alaska, Hawaii and Puerto Rico. The warranty does not cover the following:

- Damages due to shipping damage or improper installation.
- Damages due to misuse or abuse.
- Content losses due to failure of the unit.
- Inside components such as the filter, etc.
- Repairs performed by unauthorized service agents.
- Service calls that do not involve defects in material and workmanship, such as instructions on proper use of the product or improper installation.
- Replacement or resetting of house fuses or circuit breakers.
- Failure of this product if used for purposes other than its intended purpose.
- Disposal costs for any failed unit not returned to our factory.
- Any delivery or installation costs incurred as the result of a unit that fails to perform as specified.
- Expenses for travel and transportation for product service if your appliance is located in a remote area where service by an authorized service technician is not available.
- The removal and reinstallation of your appliance if it is installed in an inaccessible location or is not installed in accordance with published installation instructions.
- Refunds for non-repairable products are limited to the price paid for the unit per the sales receipt.
- This warranty is non-transferable. This warranty applies only to the original purchaser and does not extend to any subsequent owners.

### LIMITATIONS OF REMEDIES AND EXCLUSIONS

Product repair in accordance with the terms herein, is your sole and exclusive remedy under this limited warranty. Any and all implied warranties including merchantability and fitness for a particular purpose are hereby limited to one year or the shortest period allowed by law. MC Appliance Corporation is not liable for incidental or consequential damages and no representative or person is authorized to assume for us any other liability in connection with the sale of this product. Under no circumstances is the consumer permitted to return this unit to the factory without the prior written consent of MC Appliance Corporation.

Some states prohibit the exclusion or limitation of incidental or consequential damages, or limitations on implied warranties. This warranty gives you specific legal rights, and you may also have other rights which vary from state to state.

Model	Parts & Labor	Compressor (Part Only)	Type of Service
MCRAC6KEWM / MCRAC8KEWM	One-Year	Five Years	Carry In
MCRAC10KEWM / MCRAC12KEWM			

For Service or Assistance, please call 888-775-0202, email to [cshep@mcappliance.com](mailto:cshep@mcappliance.com), or visit us on the web at [www.mcappliance.com](http://www.mcappliance.com).