

Sunbeam®

UPRIGHT FREEZER INSTRUCTION MANUAL

Model No.: SBUF3W

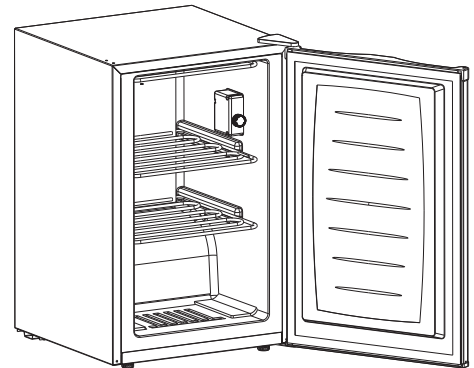

Sunbeam

© 2010 Sunbeam Products, Inc. doing business as Jarden Consumer Solutions. All rights reserved.
SUNBEAM® logo is a registered trademark of Sunbeam Products, Inc. used under license.
Distributed by MC Appliance Corporation, 777 Mark Street, Wood Dale, IL 60191

For service, support and warranty information, visit www.mcappliance.com or in the US call 877 856-0202.

To ensure proper use of this appliance and your safety, please read the following instructions completely before operating this appliance.

TABLE OF CONTENTS

NAMES OF THE PARTS.....	2
IMPORTANT SAFETY INSTRUCTIONS.....	3
INSTALLATION INSTRUCTIONS	
BEFORE USING YOUR FREEZER.....	3
INSTALLING YOUR FREEZER	3
ELECTRICAL CONNECTION.....	4
OPERATING YOUR FREEZER	
TEMPERATURE CONTROL.....	4 - 5
DEFROSTING YOUR FREEZER.....	5
CARE AND MAINTENANCE	
CLEANING YOUR FREEZER.....	6
VACATION TIME.....	6
MOVING YOUR FREEZER.....	6
ENERGY SAVING TIPS.....	6
CHANGING THE REVERSIBLE DOOR.....	7
TROUBLESHOOTING GUIDE.....	8 - 9
UPRIGHT FREEZER WARRANTY.....	10



Upright Freezer Warranty

Unless otherwise prohibited, **MC Appliance Corporation** warrants each new Freezer to be free from defects in material and workmanship and agrees to remedy any such defect or to furnish a new part(s) (at the company's option) for any part(s) of the unit that has failed during the warranty period. Parts and labor expenses are covered on this unit for a period of one year after the date of purchase. In addition, **MC Appliance Corporation** warrants the compressor (parts only) to be free from defects in material and workmanship for a period of 5 years. The consumer is responsible for all labor and transportation expenses related to the diagnosis and replacement of the compressor after the initial one-year warranty expires. **A copy of the dated sales receipt / invoice is required to receive warranty service.**

This warranty covers appliances in use within the continental United States, Puerto Rico and Hawaii. The warranty does not cover the following:

- Damages due to shipping damage or improper installation.
- Damages due to misuse or abuse.
- Content losses due to failure of the unit.
- Inside components such as door panels, door shelves, racks, upright freezer lid liners, light bulbs, etc.
- Punctures to the evaporator system due to improper defrosting of the unit.
- Repairs performed by unauthorized service agents.
- Service calls that do not involve defects in material and workmanship such as instruction on proper use of the product, door reversal or improper installation.
- Replacement or resetting of house fuses or circuit breakers.
- Failure of this product if used for other than for its intended purpose.
- Disposal costs for any failed unit not returned to our factory.
- Any delivery costs incurred as the result of a unit that fails to perform as specified.
- Expenses for travel and transportation for product service if your appliance is located in a remote area where service by an authorized service technician is not available.
- The removal and reinstallation of your appliance if it is installed in an inaccessible location or is not installed in accordance with published installation instructions.
- Liability under this warranty is limited to repair, replacement or refund. If a replacement unit is not available or the unit cannot be repaired, liability is limited to the actual purchase price paid by the consumer.
- This warranty is non-transferable.
- This warranty applies only to the original purchaser and does not extend to any subsequent owner(s).

This warranty is in lieu of all warranties expressed or implied and no representative or person is authorized to assume for us any other liability in connection with the sale of this product. Under no circumstances is the consumer permitted to return this unit to the factory without prior written consent from **MC Appliance Corporation**.

Model	Parts	Labor	Compressor (Part Only)	Type of Service
SBUF3W	One-Year	One-Year	Five Years	Carry In

For Service or Assistance please call 877 856-0202. Or visit us on the web at www.mcappliance.com to request warranty service.

	<p>freezer. The freezer is touching the wall. Re-level the freezer and move it from the wall. See "Installation Instructions".</p>
Moisture forms on inside freezer walls.	<p>Weather is hot and humid, which increases internal rate of frost build-up. This is normal. Door is slightly open. Door is kept open too long, or is opened too frequently. Open the door less often. The door is not sealed properly.</p>
Moisture forms on outside of freezer.	<p>Door is slightly open, causing cold air from inside the freezer to meet warm moist air from outside.</p>
The door will not close properly.	<p>The freezer is not on a level surface. The gasket is dirty.</p>

NAMES OF THE PARTS

MODEL NO. SBUF3W

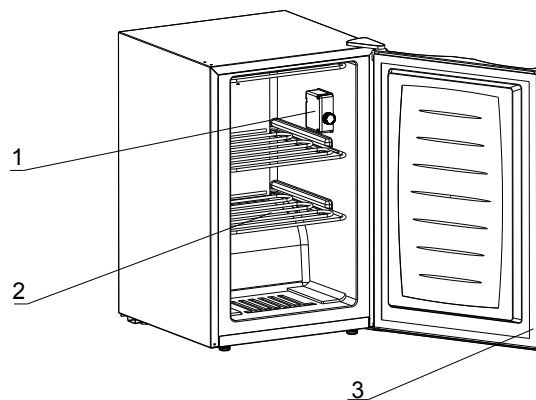

1. **Thermostat Dial**
2. **Evaporator Shelves**
3. **Magnetic Gasket**

⚠WARNING⚠: Never touch the interior of the Freezer Chamber or frozen foods in the compartment with wet hands as this could result in frost bite.

IMPORTANT SAFETY INSTRUCTIONS

⚠ WARNING ⚠	To reduce the risk of fire, electrical shock, or injury when using your freezer, follow these basic precautions:
<ul style="list-style-type: none"> • Read all instructions before using the freezer. • DANGER or WARNING: Risk of child entrapment. • To avoid the possibility of child entrapment, please take the following precautions: Never allow children to operate, play with, or crawl inside the freezer. • Before you throw away your old freezer: Take off the door so that children may not easily be entrapped. • It is dangerous to alter the specifications or attempt to modify this product in any way. • Never clean freezer parts with flammable fluids. The fumes can create a fire hazard or explosion. • Do not store or use gasoline or any other flammable vapors and liquids in the vicinity of this or any other freezer. The fumes can create a fire hazard or an explosion. • All freezer products contain refrigerants, which under the guidelines of federal law must be removed before disposal. It is the consumer's responsibility to comply with federal and local regulations when disposing of this unit. 	
-Save these instructions-	

INSTALLATION INSTRUCTIONS

Before Using Your Freezer

- Remove the exterior and interior packing.
- Check to be sure you have all of the following parts:
 - 1 Instruction Manual
- Before connecting the freezer to the power source, let it stand upright for approximately 4 hours. This will reduce the possibility of a malfunction in the cooling system from improper handling during transportation.
- Clean the interior surface with lukewarm water using a soft cloth. (Cleaning instruction on page 6)

Installing Your Freezer

- This appliance is designed to be free standing only, and should not be recessed or built-in.
- Place your freezer on a floor that is strong enough to support the freezer when it is fully loaded.
- Allow 5 inches of space between the back and sides of the freezer, which allows the proper air ventilation. Adjust the feet to keep the freezer level.
- Locate the freezer away from direct sunlight and sources of heat (stove, heater, radiator, etc.). Direct sunlight may affect the acrylic coating and heat sources may increase electrical consumption. Ambient temperature below 50°F or above 85°F will hinder the performance of this appliance. **This unit is not designed for use in a garage or any other outside installation.**
- Avoid locating the freezer in moist areas.
- Plug the freezer into dedicated, properly installed-grounded wall outlet. Do not under any circumstances cut or remove the third (ground) prong from the power cord. Any questions concerning power and/or grounding should be directed toward a certified electrician or an authorized service center. **This unit is not designed to be installed in an RV or used with an inverter.**
- After plugging the appliance into a wall outlet, allow the unit to cool down for 2-3 hours under before placing food in the freezer compartment.

TROUBLESHOOTING GUIDE

You can solve many common freezer problems easily, saving you the cost of a possible service call. Try the suggestions below to see if you can solve the problem before calling for service.

PROBLEM	POSSIBLE CAUSE
Freezer does not operate.	Not plugged in. The circuit breaker tripped or a blown fuse.
Compressor turns on and off frequently.	The room temperature is hotter than normal. A large amount of food has been added to the freezer. The door is opened too often. The door is not closed completely. The temperature control is not set correctly. The door gasket does not seal properly. The freezer does not have the correct clearances. The freezer has recently been disconnected for a period of time. 4 hours are required for the freezer to cool down completely.
Temperature inside the freezer is too warm.	Temperature control is set too warm. Turn the control to a cooler setting and allow several hours for the temperature to stabilize. Door is kept open too long or is opened too frequently. Warm air enters the freezer every time the door is opened. Open the door less often. The door is not closed completely. The door gasket does not seal properly. A large amount of warm or hot food might have been stored recently. Wait until the freezer has had a chance to reach its selected temperature. The freezer has recently been disconnected for a period of time. 4 hours are required for the freezer to cool down completely.
Temperature inside the freezer is too cold.	Temperature control is set too cold. Turn the control to a warmer setting and allow several hours for the temperature to stabilize.
Temperature of external freezer surface is warm.	The exterior freezer walls can be as much as 30 F warmer than room temperature. This is normal while the compressor works to transfer heat from inside the freezer cabinet.
Popping or cracking sound when compressor comes on.	Metal parts undergo expansion and contraction, as in hot water pipes. This is normal. Sound will level off or disappear as freezer continues to run.
Bubbling or gurgling sound, like water boiling.	Refrigerant (used to cool freezer) is circulating throughout the system. This is normal.
Vibrations.	Check to assure that the freezer is on a level surface. Floor is uneven or weak. Freezer rocks on the floor when it is moved slightly. Be sure floor can adequately support freezer. Level the freezer by putting wood or metal shims under part of the

CHANGING THE REVERSIBLE DOOR

CAUTION: To avoid personal injury to yourself and/or property, we recommend someone assist you during the door reversal process.

The freezer has been built with the door hinges on the right. If you wish to change the opening direction, follow the instruction below:

Note:

- Unplug the freezer from its electrical outlet
- Empty everything in the freezer, including all food items.
- All parts removed during the process must be saved to reinstall the door.

1. Remove the top hinge cover.
2. Using Phillips Head Screwdriver, loosen and remove the screws holding the top hinge in place.
3. Remove top hinge and carefully lift off the door.
4. Remove the screw hole plugs from the opposite side and insert the plugs in the screw hole openings of the just removed screws.
5. Remove any loose items in the refrigerator and carefully turn refrigerator on its back, remove both leveling legs and place in a secure area.
6. Loosen the screws holding the lower hinge bracket to the refrigerator and remove screws and bracket.
7. Remove (2) screws from the other side and insert in the previously removed screw holes.
8. Remove door pin by turning counter clockwise and reinsert to the underside of the bracket and tighten.
9. Align bracket and insert (2) remaining screws into the holes provided.
10. Align hole in the door with the door pin and washer and gently push down until firm.
11. Align upper hinge bracket with screw holes insert screws and partially secure, check that door and cabinet are properly aligned and then secure tightly.
12. Replace hinge cap.

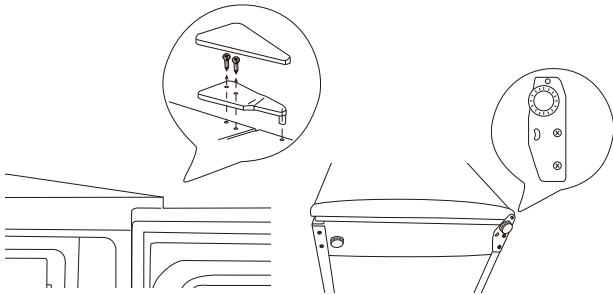

Electrical Connection

⚡WARNING⚡

Improper use of the grounded plug can result in the risk of electrical shock. If the power cord is damaged, have it replaced by an authorized service center.

This freezer should be properly grounded for your safety. The power cord of this freezer is equipped with a three-prong plug which mates with standard three prong wall outlets to minimize the possibility of electrical shock.

Do not, under any circumstances, cut or remove the third ground prong from the power cord supplied.

This freezer requires a standard 115/120 Volt A.C. ~60Hz electrical outlet with three-prong ground.

This freezer is not designed to be used with an inverter.

The cord should be secured behind the freezer and not left exposed or dangling to prevent accidental injury.

Never unplug the freezer by pulling the power cord. Always grip the plug firmly and pull straight out from the receptacle.

Do not use an extension cord with this appliance. If the power cord is too short, have a qualified electrician or service technician install an outlet near the appliance. Use of an extension cord can negatively effect the performance of the unit.

OPERATING YOUR FREEZER

Temperature Control

- The thermostat control knob located in the right side regulates the temperature of the freezer compartment.
- The first time you turn the unit on, adjust thermostat control to required setting and run for at least 4 hours before putting frozen foods inside. This will ensure the cabinet is thoroughly chilled before food is put in.
- The range of the temperature control is from position "1" (cold) to "7" (coldest). Adjust the temperature control to the setting that best suits your needs.
- The setting of "4" should be appropriate for home or office freezer use.
- To adjust temperature to colder or warmer setting, please adjust the temperature control one numerical increment at a time.
- After each one numerical increment temperature adjustment, allow the freezer to operate at adjusted temperature for several hours for the freezer temperature to stabilize.
- To stop the freezer cooling process, turn the temperature control to "0". However, turning the temperature control to "0" position does not shut off the power to the freezer.

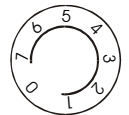

• **NOTE;**

- If the unit is unplugged or loses, you must wait 3 to 5 minutes before restarting the unit. If you attempt to restart before this time delay, the freezer will not start.
- Large amounts of food will lower the cooling efficiency of the appliance.
- If you choose to change the thermostat setting, adjust thermostat control by one numerical increment at a time. Allow several hours for temperature to stabilize between adjustments.

Defrosting Your Freezer

- **When?** For the most efficient operation and minimum energy consumption, defrost the freezer when the frost on the freezer walls is excessive or ¼ to ½ inch thick.
- Choose a time when the stock of frozen food is low.

CAUTION

Do not use boiling water because it may damage the plastic parts. In addition, never use a sharp or metallic instrument to remove frost as it may damage the cooling coils and will void the warranty.

- Remove the frozen food from the freezer and place it in a cooler to protect the food.
- Unplug the appliance.
- Open the freezer door.
- During defrosting, the ice melts into the cabinet. Place a suitable container to collect the defrosted water.
- Check the container occasionally so the water does not overflow.
- After defrosting is completed, clean and thoroughly dry the interior of the freezer.
- Plug in the appliance and reset the thermostat to desired setting.
- Allow the cabinet to cool for 4 hours.
- Return food to the freezer.

HELPFUL HINT:

Defrosting usually takes a few hours. Leaving the door open will help speed the process. Also, pouring warm water (not boiling) on the ice/frost will help speed melting.

⚠WARNING⚠

Scraping ice from the freezer compartment can damage the unit.

CARE AND MAINTENANCE

Cleaning Your Freezer

- Upon installation of your new appliance, it is recommended that it be cleaned thoroughly.
- Unplug the freezer, remove the food and storage basket.
- Wash the inside with a damp warm cloth soaked in lukewarm water and baking soda solution. The solution should be about 2 tablespoons of baking soda to a quart of water.
- Be sure to keep the door gasket (seal) clean to keep the unit running efficiently.
- The outside of the freezer should be cleaned with mild detergent and warm water.
- Dry the interior and exterior with a soft cloth.
- It is recommended that the unit be cleaned each time it is defrosted to help keep the unit odor free and running efficiently.

Vacation Time

- Remove all the food.
- Unplug the freezer.
- Clean the freezer.
- Leave the door open slightly to avoid possible formation of condensation, mold, or odors.
- Use extreme caution in the case of children. The unit should not be accessible to child's play.
- **Short vacations:** Leave the freezer operating during vacations of less than three weeks.
- **Long vacations:** If the appliance will not be used for several months, remove all food and unplug the power cord. Clean and dry the interior thoroughly. To prevent odor and mold growth, leave the door open slightly; blocking it open if necessary or have the door removed.

Moving Your Freezer

- Unplug the freezer.
- Remove all the food.
- Securely tape down all loose items inside your freezer.
- Tape the doors shut.
- Be sure the freezer stays in the upright position during transportation.

Energy Saving Tips

- The freezer should be located in the coolest area of the room, away from heat producing appliances or heating ducts, and out of the direct sunlight.
- Let hot foods cool to room temperature before placing in the freezer. Overloading the freezer forces the compressor to run longer. Foods that freeze too slowly may lose quality, or spoil.
- Be sure to wrap foods properly, and wipe containers dry before placing them in the freezer. This cuts down on frost build-up inside the freezer.
- Freezer should not be lined with aluminum foil, wax paper, or paper toweling. Liners interfere with cold air circulation, making the freezer less efficient.
- Organize and label food to reduce door openings and extended searches. Remove as many items as needed at one time, and close the door as soon as possible.